

CS-2907/CS-2917 SERIES

50mA F to V Converter

Description

The CS-2907/2917 Series is designed for use in frequency-to-voltage conversion systems and is especially suitable for tachometer and motor-speed-control applications. The 2907 consists of a regenerative input comparator, a frequency doubling charge pump and a general purpose, differential op-amp output. The 2917 has the additional built-in feature of an internal shunt voltage regulator. The input signal, which can be single-ended, or differential, is applied to the regenerative comparator input; 30mV hysteresis provides noise rejection.

The frequency-doubling charge pump is triggered by the comparator output, converting the input-frequency information into a d.c. output voltage at F/V_{OUT} . The output op-amp is unity-gain compensated and can serve as an output-voltage follower or as an active filter for additional ripple reduction. 50mA current capability allows the output stage to drive a variety of loads either from emitter, or collector. The output swings to ground for zero frequency input.

Absolute Maximum Ratings

Supply Voltage.....	28V
Supply Current.....	25mA
Op. Amp./Comp. Differential Input Voltage.....	28V
Op. Amp./Comparator Input Voltage.....	28V
Op. Amp. Collector-Emitter Voltage.....	28V
Digital Interface Collector-Emitter Voltage.....	28V
Operating Temperature Range.....	-40°C to +85°C
Storage Temperature Range.....	-65°C to +150°C
Lead Temperature Soldering	
Wave Solder(through hole styles only).....	10 sec. max, 260°C peak

Block Diagram

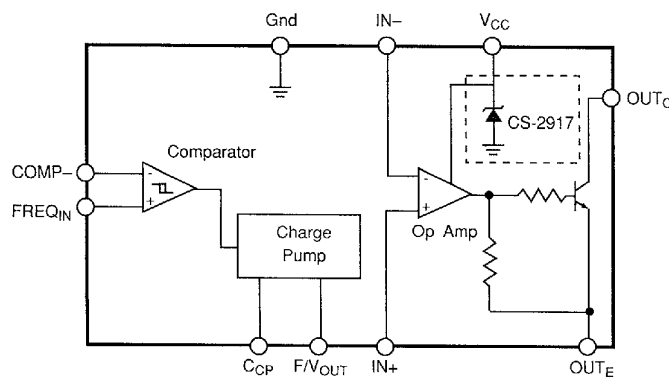

Features

- ±0.3% Linearity, Typical
- Buffered High-Level Frequency Output
- Single-ended or Differential Inputs
- Voltage Follower or Active Filter Output Capability
- Output Swings to Ground for Zero Frequency Input

Package Options

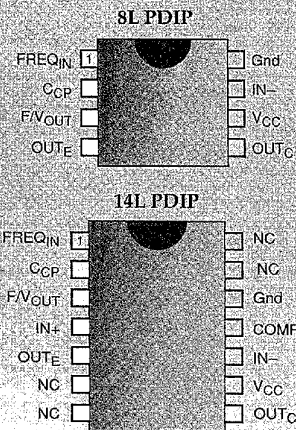

Cherry Semiconductor Corporation
 2000 South County Trail
 East Greenwich, Rhode Island 02818-1530
 Tel: (401)885-3600 Fax (401)885-5786

Electrical Characteristics: $T_A = 25^\circ\text{C}$ and $V_{CC} = 12V_{DC}$ unless otherwise noted

PARAMETER	TEST CONDITIONS	MIN	TYP	MAX	UNIT
■ Comparator					
Input Threshold Voltage	$V_{FREQIN} = \pm 125\text{mV}$ note 2	± 10	± 15	± 40	mV
Hysteresis	$V_{FREQIN} = \pm 125\text{mV}$ note 2		30		mV
Input Offset Voltage					
-D14 Versions	note 2		3.5	10	mV
-D8 Versions	note 2		5	15	mV
Input Bias Current	$V_{FREQIN} = \pm 50\text{mV}$		0.1	1.0	μA
Common Mode Voltage				$V_{CC} - 1.5$	V
■ Charge Pump					
Output Voltage - high, V_{OH}					
CS-2907 Series	$V_{FREQIN} = +125\text{mV}_{DC}$ note 3		8.3		V
CS-2917 Series	$V_{FREQIN} = +125\text{mV}_{DC}$ note 3		5		V
Output Voltage - low, V_{OL}					
CS-2907 Series	$V_{FREQIN} = -125\text{mV}_{DC}$ note 3		2.3		V
CS-2917 Series	$V_{FREQIN} = -125\text{mV}_{DC}$ note 3		1.2		V
Output Current $I_{pin 2, pin 3}$					
CS-2907 Series	$V_{CCP} = V_F/V_{OUT} = 6V_{DC}$ note 4	140	180	240	μA
CS-2917 Series	$V_{CCP} = V_F/V_{OUT} = 3.5V_{DC}$ note 4 $V_{CC} = 6V_{DC}$	120	160	250	μA
Leakage Current $I_{pin 3}$	$I_{CCP} = 0; V_F/V_{OUT} = 0$			0.1	μA
Gain Constant K	note 3	0.9	1.0	1.1	
Non-Linearity	note 5	-1.0	+0.3	+1.0	%
■ Op. Amp.					
Input Offset Voltage					
CS-2907 Series	$V_{IN} = 6V_{DC}$		3	10	mV
CS-2917 Series	$V_{IN} = 3.5V_{DC}$		3	10	mV
Input Bias Current					
CS-2907 Series	$V_{IN} = 6V_{DC}$		0.05	0.5	μA
CS-2917 Series	$V_{IN} = 3.5V_{DC}$		0.05	0.5	μA
Common Mode Voltage		0		$V_{CC} - 1.5$	V
Open Loop Gain			200		V/mV
I_{SINK}	$V_{OUTC} = 1V$	40	50		mA
I_{SOURCE}					
CS-2907 Series	$V_{OUTE} = V_{CC} - 2V$		10		mA
CS-2917 Series	$V_{OUTE} = V_{CC} - 2V; V_{CC} = 6V_{DC}$		10		mA
Saturation Voltage					
	$I_{SINK} = 5\text{mA}$		0.1	0.5	V
	$I_{SINK} = 20\text{mA}$			1.0	V
	$I_{SINK} = 50\text{mA}$		1.0	1.5	V
■ Zener Regulator (CS-2917 Series Only)					
Regulator Voltage	Dropping Resistor = 470Ω		7.56		V
Series Resistance			10.5	15	Ω
Temperature Stability			+1		mV/ $^\circ\text{C}$
■ Supply					
Current, Quiescent					
CS-2907 Series	$V_{CC} = 12V_{DC}$		3.8	6.0	mA
CS-2917 Series	$V_{CC} = 6V_{DC}$	3.0	6.0		mA

Electrical Characteristics: continued

Notes:

- Above 25° Derate at 8.0mW/°C for package D₁₄ and at 10.0mW/°C for package D₈.
- Hysteresis is the sum +V_{TH}-(V_{TH}), offset voltage is their difference.
- V_{OH} is equal to 3/4 x V_{CC} - 1V_{BE}, V_{OL} is equal to 1/4 x V_{CC} - 1V_{BE} therefore V_{OH} - V_{OL} = V_{CC}/2. The difference, V_{OH} - V_{OL}, and the mirror gain, I₂/I₃, are the two factors that cause the tachometer gain constant to vary from 1.0.
- Be sure when choosing the time constant R₁ x C₁ that R₁ is such that the maximum anticipated output voltage at F/V_{OUT} can be reached with I₃ x R₁. The maximum value for R₁ is limited by the output resistance of F/V_{OUT} which is greater than 10MΩ typ.
- Nonlinearity is defined as the deviation of V_{OUT} (@ F/V_{OUT}) for f_{IN} = 5kHz from a straight line defined by the V_{OUT} @ 1kHz and V_{OUT} @ 10kHz, C₁ = 1000pF, R₁ = 68kΩ and C₂ = 0.22μF.

Package Pin Description

PACKAGE PIN #				PIN SYMBOL	FUNCTION
8L PDIP		14L PDIP			
CS-2907	CS-2917	CS-2907	CS-2917		
1	1	1	1	FREQ _{IN}	Analog input signal from speed sensor.
		11	11	COMP-	Inverted input to comparator; connected to Gnd in D8.
2	2	2	2	C _{CP}	Charge pump capacitor.
3	3	3	3	F/V _{OUT}	Charge pump output, the charge on the capacitor is measured at the output.
4	4	5	5	OUT _E	Emitter of op amp's output stage.
5	5	8	8	OUT _C	Collector of op amp's output stage.
6	6	9	9	V _{CC}	Supply voltage.
		4	4	IN+	Positive input to op amp.
7	7	10	10	IN-	Negative input to op amp.
		6, 7, 13, 14	6, 7, 13, 14	NC	No connection.
8	8	12	12	Gnd	Ground connection.

Applications

A timing capacitor C_{CP}, an output resistor R_F, and an output filter capacitor C_F, are required as shown in Figure 1. On each transition of the input comparator, C_p is linearly charged or discharged between voltage limits V_H and V_L. The difference, V_H-V_L, equals V_{CC}/2. During one half cycle of input frequency, the change in charge on CCP is: C_{CP} V_{CC}/2. The average charge-pump current charging C_{CP} during one half cycle of input frequency = C_{CP} V_{CC} F_{IN} where F_{IN} = input frequency. This charge pump current, I_C, is accurately mirrored into R_F to generate a DC voltage at F/V_{OUT} such that V_F/V_{OUT} = I_CR_F = K R_FC_{CP} V_{CC} F_{IN} where K is a circuit constant typically equal to one. Averaging, or filtering is accomplished with C_F and both output ripple voltage and response time are dependent on the value of C_p Peak to peak ripple voltage V_R = (V_{CC}/2) (C_{CP}/C_F) (1-F_{IN}/F_{max}) where F_{max} = 12/(C_{CP} V_{CC}) and I_F is the current in C_F.

For the 2917 series on-board shunt-regulator an external resistor R₂ is required for operation from the input supply voltage.

The value of R_F does not therefore affect ripple; however if it is too large by comparison with the output impedance

seen at F/V_{OUT}, linearity will be adversely affected. Since the current at F/V_{OUT}, I_F/V_{OUT}, is internally set, R_F must be chosen such that V_F/V_{OUT} max. = I_F/V_{OUT}R_F.

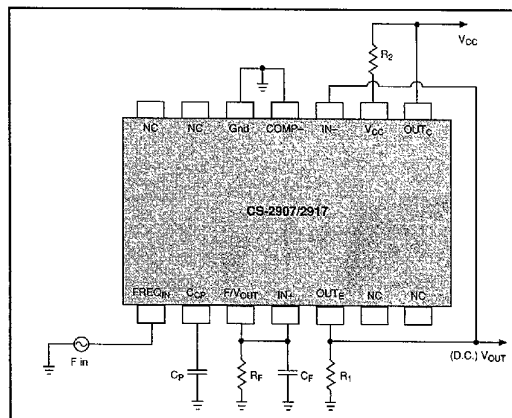

Figure 1: Application Diagram

CS-2907/2917 Datasheet

Motor Speed Control Application

The CS-2917 F-to-V converter integrated circuit, with built-in operational amplifier, regulator, and output transistor is ideal for tachometer feedback motor speed control applications. Two typical application circuits are shown in Figure 2. Figure 2A employs the CS-2907-N14 operating from the V_{CC} line. Figure 2B offers an alternative approach using the CS-2917-N8 operating from the V_{CC} line and using the internal regulator. In both circuits, the tachometer feedback-signal is applied to the comparator input, and the F-to-V conversion gain is set by $C_{CP}R_F$. The general purpose op amp is used both as a summing node for the speed reference input (from potentiometer R_T), and as a frequency compensated integrator which provides zero steady state speed error under varying load

conditions. Capacitors C_2 and C_3 provide the integrating function at low frequency while R_2 and C_2 provide the frequency compensation which insures loop stability. In Figure 2A, the on-chip driver transistor drives a discrete power transistor which in turn drives the motor. In Figure 2B, the on-chip driver transistor is used as an inverting gain stage to close the loop around the op amp, and the provide drive voltage for the discrete NPN darlington transistor which drives the motor.

Both of these approaches provide accurate regulation of motor speed under conditions of varying motor load, V_{CC} and ambient temperature.

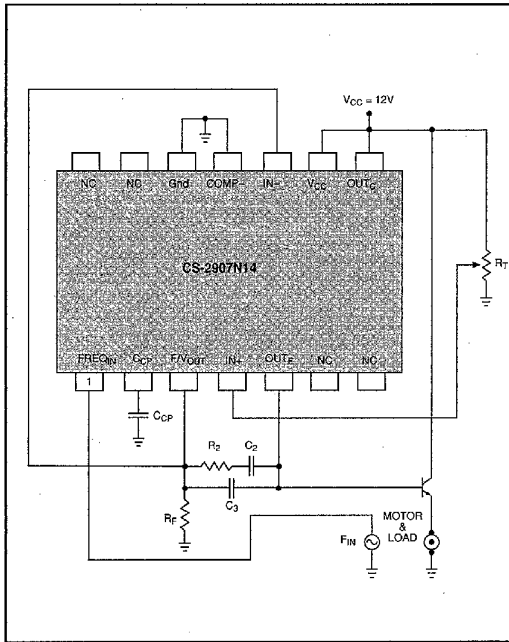

Figure 2A: Motor Speed Control with CS-2907N14.

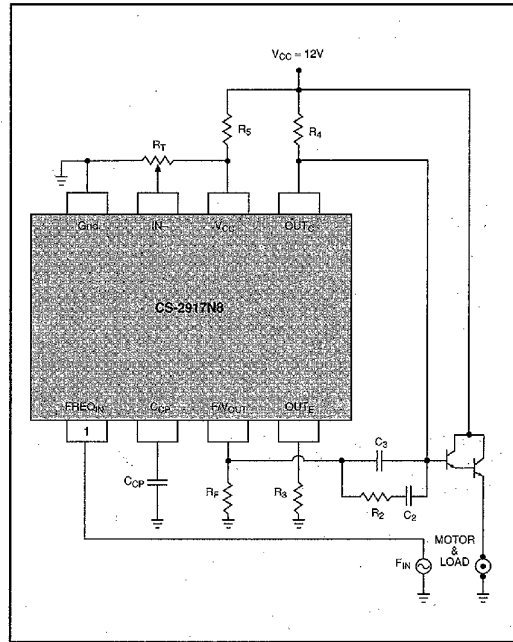

Figure 2B: Motor Speed control with CS-2917N8.

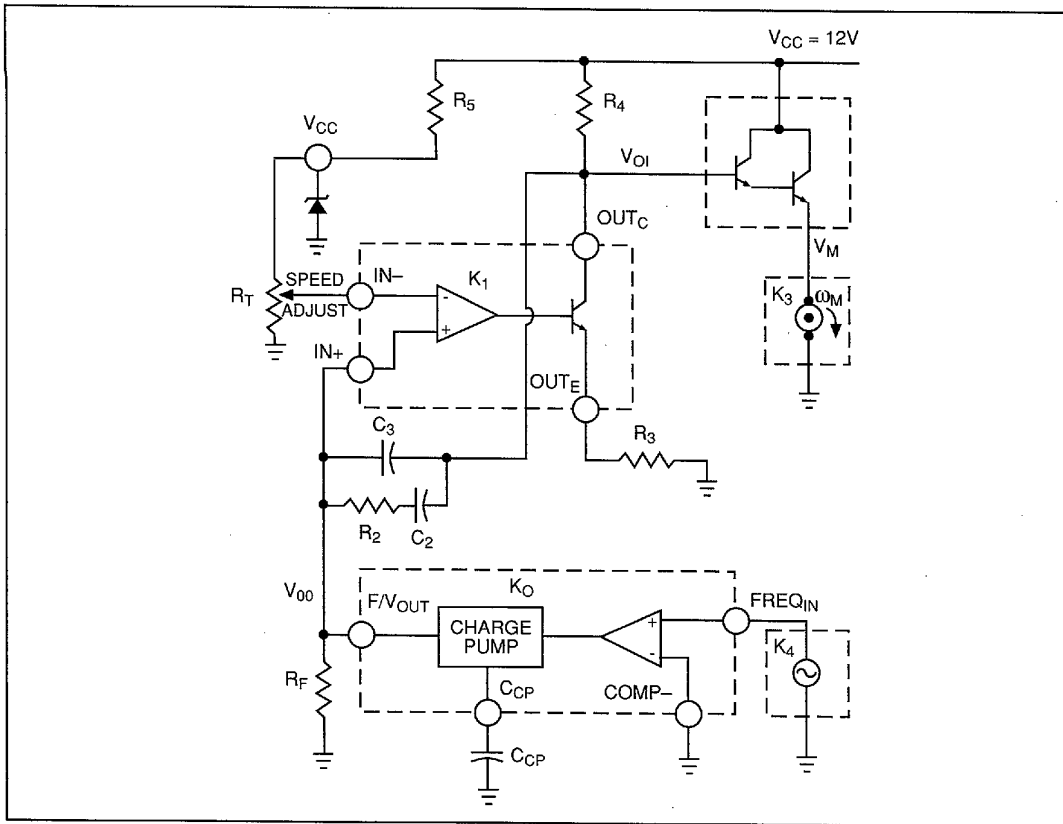

Figure 3: Motor Speed Control Block Diagram of CS-2917N8.

Figure 3 is the circuit of Figure 2B re-drawn in a block diagram form which lends itself to visualization and analysis of the regulator loop. (Figure 2A can be analyzed in the same manner.) Potentiometer R_T provides the loop reference input. The op amp integrator, the power darlington and the motor provide the forward gain components K_1 , K_2 and K_3 . The tachometer and F-to-V converter provide the gain components K_4 and K_0 in the feedback path. We will now derive the transfer functions for all components of the loop, write the expression for loop gain, and compute component values to insure loop stability.

A. K_0 is the transfer function for the F-to-V converter.

$$1. \quad K_0 \frac{V_{00}}{f_{IN}} = K_V R_F C_{CP}; \quad K = 1.0; \quad V_R = 7.6V$$

B. K_1 is the transfer function for the integrator.

$$2. \quad K_1 = \left| \frac{V_{01}}{V_{00}} \right| = \frac{1 + j\omega R_2 C_2}{j\omega R_F (C_2 + C_3) \left[1 + \frac{j\omega C_2 C_3 R_2}{C_2 + C_3} \right]}$$

This transfer function has the following poles and zeros:

$$\text{Zero at: } \omega_1 = \frac{1}{R_2 C_2}$$

Pole at: $\omega = 0$ (an integrator)

$$\text{Pole at: } \omega_2 = \frac{C_2 + C_3}{R_2 C_2 C_3}$$

C. K_2 is the transfer function of the power darlington transistor. Assume it equals 0.9 over the frequency range of interest.

$$3. \quad K_2 = \frac{V_m}{V_{01}} = 0.9$$

D. K_3 is the transfer function of the motor. (See Electrocraft Engineering Handbook, 4th edition, Pg. 2-19, eq. 2.3.28.)

$$4. \quad K_3 = \frac{\omega_m}{V_m} = \frac{1/K_E}{(1 + j\omega J_m)(1 + j\omega J_c)}$$

ω_m = Motor Rotational Speed (rad/sec)

V_m = Applied Motor Voltage

$J_m = (R_A J_T / K_E K_T)$ = Mechanical Time Constant



Design Example

- $J_e = (L_A/R_A) =$ Electrical Time Constant
- $K_T =$ Motor Torque Const. (oz • in/A)
- $K_E =$ Motor Back EMF Const. (V/rad/sec)
- $R_A =$ Motor Armature Resistance (ohms)
- $L_A =$ Motor Armature Inductance (henrys)
- $J_T =$ Total Inertial Load on Motor (oz • in • sec²)

This design example describes an application using a small, permanent-magnet fractional-horsepower d.c. motor driving an inertial load. The following parameter values are taken from manufacturer's data for the motor and from laboratory measurements on the drive system.

- $\omega_m = 314.2$ rad/sec (3000 rpm)
- $K_T = 2.1$ oz. in/A = 14.83×10^{-3} N.M/A
- $K_E = 14.83 \times 10^{-3}$ V/rad/sec
- $R_A = 6.9\Omega$
- $J_e = 0.7$ msec
- $\therefore L_A = 4.83$ mh, and
- $J_T = 9.39 \times 10^{-4}$ oz • in • SEC²
- $= 6.63 \times 10^{-6}$ kg • m²

5.
$$J_m = \frac{R_A J_T}{K_E K_T} = 0.208 \text{ sec}$$

$$\omega_B = \frac{1}{J_m} = 4.8 \text{ rad/sec}$$

$$f_B = 0.765 \text{ Hz}$$

$$\omega_e = \frac{1}{J_e} = 1429 \text{ rad/sec}$$

$$f_e = 227 \text{ Hz}$$

$$1/K_e = 67.4$$

6.
$$K_3 = \frac{\omega_m}{V_m} = \frac{67.4}{\left(1 + j \frac{\omega}{4.8}\right) \left(1 + j \frac{\omega}{1429}\right)}$$

Ignoring the electrical time constant (assumes that the loop crossover frequency is less than 1429 rad./sec.) we have:

7.
$$K_E = \frac{\omega_m}{V_m} = \frac{67.4}{\left(1 + j \frac{\omega}{4.8}\right)}$$

E. K_4 is the tachometer constant.

$$\omega_m K_4 = f_{in}$$

for $f_{in} = 400$ Hz, $\omega_m = 314.2$ rad/sec and

8. $K_4 = 1.273$ cyc/rad

The loop gain, A_L , equals.

9. $A_L = K_0 K_1 K_2 K_3 K_4$ at $\omega = 1$ rad/sec, for

$$1 < W_B < W_1, < W_Z$$

$$A_L (\omega = 1)$$

$$= 7.6(R_1 C_1) \frac{1}{R_F(C_2 + C_3)} (0.9)(67.4)(1.273)$$

Arbitrarily selecting a loop gain of 50 (34db) at $\omega = 1$ rad/sec, we derive the following expression:

$$\frac{C_{CP}}{C_2 + C_3} = \frac{50}{(7.6)(0.9)(67.4)(1.273)} = 0.0852$$

10. $C_2 + C_3 = 11.74 C_1$

Now, select $R_1 C_1$ to set the loop reference voltage to about 1/2 of the on-chip zener reference voltage:

11. $K_4 \omega_m \cdot K_0 = V_{REF} \approx 7.6/2$

By selecting standard values for C_{CP} and R_F , $C_{CP} = 0.01\mu\text{F}$ and $R_F = 146\text{k}\Omega$, the reference voltage at the loop operating point is:

12. $V_{REF} = (314.2 \text{ rad/sec}) (7.6) (1.0) (0.01\mu\text{F})$
 $(146\text{k}) (1.273) = 4.4 \text{ volts}$

4.4 volts is well within the regulated supply tolerance and should present no adjustment problem in production.

Now, plot the bode diagram for the loop with only the integrator response and motor break frequency, $f_B = 0.765\text{Hz}$ and determine suitable locations for f_1 and f_2 such that the compensated bode plot crosses the unity gain axis at about the mid point of the -6db/octave line segment connecting f_1 and f_2 . Selecting $f_1 = 1.5\text{Hz}$, and $f_2 = 7.0\text{Hz}$ we have; (see Figure 4)

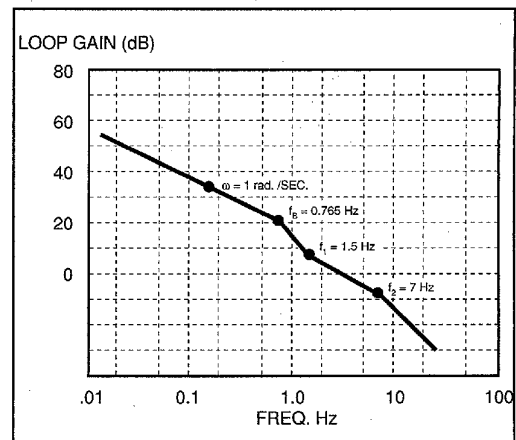

Figure 4.



CS-2907/2917 SERIES

Resistors R_3 and R_4 are chosen to bias the on-chip drive transistor in a linear region at the desired motor speed. To maintain closed loop stability of the integrator we keep the inverting gain of this stage close to unity. For this application $R_3 = 570\Omega$ and $R_4 = 1000\Omega$. A 470Ω resistor is selected for R_5 to provide sufficient zener bias from the 12V supply. The component list for the circuit in Figure 2B is:

$R_F = 146k\Omega$	$C_{CP} = 0.01\mu F$
$R_2 = 1M\Omega$	$C_2 = 0.1\mu F$
$R_3 = 510\Omega$	$C_3 = 0.022\mu F$
$R_4 = 1000\Omega$	
$R_5 = 470\Omega$	
$R_T = 100k\Omega$	

This design example illustrates a method for computing component values to insure closed loop stability of the motor speed regulator system. It is based on an application circuit which includes an integrator to provide for zero steady state error under varying load conditions. This system, with loop gain equal to 50 at ω equals 1 rad/sec gave acceptable static and dynamic performance for the intended application.

$$f_1 = \frac{1}{2\pi R_2 C_2} = 1.5\text{Hz}$$

$$f_2 = \frac{C_2 + C_3}{2\pi R_2 C_2 C_3} = 7.0\text{Hz}$$

$$\frac{f_1}{f_2} = \frac{C_3}{C_2 + C_3} = 0.214$$

$$C_3 = 0.214 (C_2 + C_3)$$

From Equation 10

$$C_2 + C_3 = 11.74 C_{CP} = 0.1174\mu F$$

$$C_3 = (0.214) (0.1174) = 0.025\mu F$$

Select $C_3 = 0.022\mu F$

and $C_2 = 0.1\mu F$

Then;

$$R_2 = \frac{1}{2\pi f_1 C_2} = 1M\Omega$$

Package Specification

PACKAGE DIMENSIONS IN mm (INCHES)

Lead Count	D			
	Metric		English	
	Max	Min	Max	Min
8L PDIP	9.40	9.14	.370	.360
14L PDIP	19.18	18.92	.755	.745

PACKAGE THERMAL DATA

Thermal Data		8 Lead PDIP	14 Lead PDIP	
$R_{\theta JC}$	typ	52	48	$^{\circ}C/W$
$R_{\theta JA}$	typ	100	85	$^{\circ}C/W$

8L and 14L PDIP: 300 mil wide

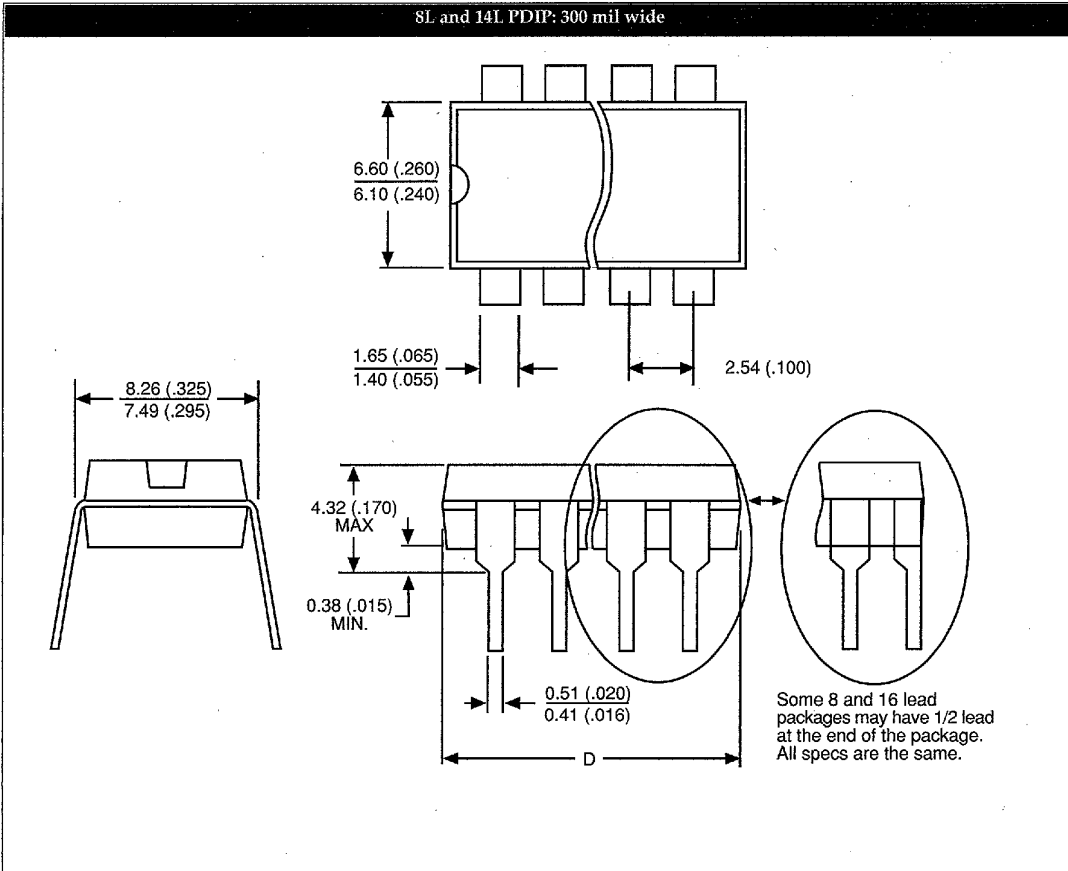

Ordering Information

Part Number	Description
CS-2907N14	14 Lead PDIP
CS-2907N8	8 Lead PDIP
CS-2917N14	14 Lead PDIP
CS-2917N8	8 Lead PDIP