

ACE9020 is a VHF oscillator, up-converter and prescaler. It is used in an offset modulated transmit architecture where a UHF synthesiser makes the channel selection and a second synthesiser generates a fixed transmit offset.

A VCO signal drives a buffer in ACE9020 to feed an on-chip prescaler and transmit up-converter. The prescaler is a dual two-modulus divider and drives the main synthesiser input of the ACE9030. The SSB up-converter suppresses the unwanted transmit sideband.

The VHF oscillator is buffered to drive the auxiliary synthesiser input of the ACE9030 and is locked to the offset frequency. This frequency is modulated by varying the resonant frequency of the external tank circuit. Both this oscillator and the UHF VCO drive the up-converting mixer to generate the transmit signal.

Various power saving modes for battery economy are included. These allow the transmit sections to be shut down during stand-by and the whole chip can be shut down during sleep mode. The circuit techniques used have been chosen to minimise external components and at the same time give very high performance.

Features

- Low Power Low Voltage (3.6 to 5.0 V) Operation
- Power Down Modes
- Differential Signals to Minimise Cross-talk
- Auxiliary Oscillator with Transmit Up-converter
- Prescaler for Main Synthesiser
- Part of the ACE Integrated Cellular Phone Chipset
- Small Outline 28 pin Package

Applications

- AMPS and TACS Cellular Telephone
- Two-Way Radio Systems

Related Products

ACE9020 is part of the following chipset:

- ACE9030 Radio Interface and Twin Synthesiser
- ACE9040 Audio Processor
- ACE9050 System Controller and Data Modem

ABSOLUTE MAXIMUM RATINGS

Supply voltage	6V
Storage temperature	- 65°C to + 150°C
Operating temperature	- 30°C to + 85°C
Voltage at any pin	-0.3V to V _{CC} +0.3V
Static Sensitivity (HBM) min	500V

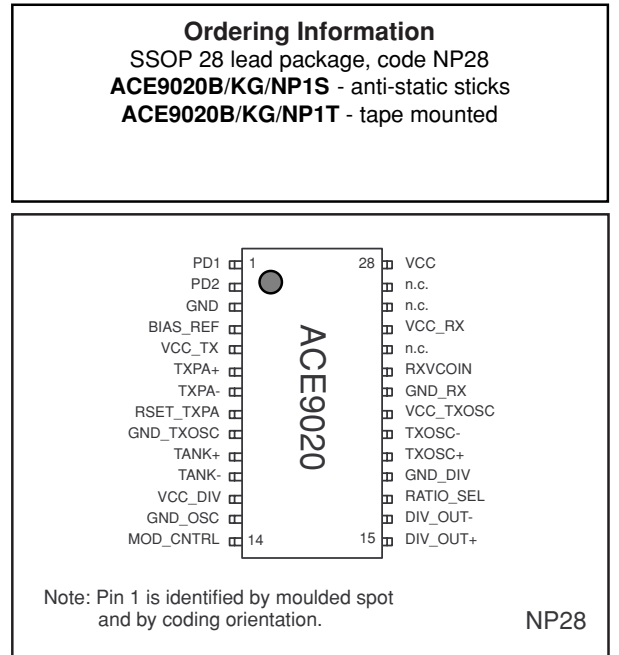

Figure 1 - Pin connections - top view

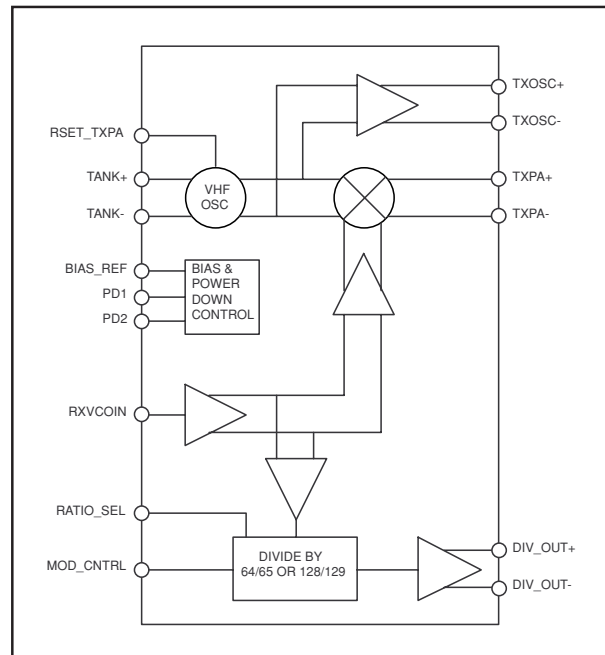

Figure 2 - ACE9020 simplified block diagram

ACE9020

PIN Connections

Pin No.	Name	Type	Description
1	PD1	I	Power down control input 1
2	PD2	I	Power down control input 2
3	GND	Supply	Ground
4	BIAS_REF	I	Reference current for bias control
5	VCC_TX	Supply	Transmit section supply voltage
6	TXPA+	O	Transmit up-converter open collector output
7	TXPA-	O	Transmit up-converter open collector output
8	RSET_TXPA	I	Reference current for transmit oscillator
9	GND_TXOSC	Supply	Ground
10	TANK+	I	Transmit oscillator tank circuit
11	TANK-	I	Transmit oscillator tank circuit
12	VCC_DIV	Supply	Divider section supply voltage
13	GND_OSC	Supply	Ground
14	MOD_CNTRL	I	Modulus control input
15	DIV_OUT+	O	Divider output positive
16	DIV_OUT-	O	Divider output negative
17	RATIO_SEL	I	Ratio select
18	GND_DIV	Supply	Ground divider section
19	TXOSC+	O	Transmit oscillator monitor output positive
20	TXOSC-	O	Transmit oscillator monitor output negative
21	VCC_TXOSC	Supply	Transmit oscillator supply voltage
22	GND_RX	Supply	Ground
23	RXVCOIN	I	Input buffer for 1GHz VCO signal from ACE9010
24	n.c.	-	No connection
25	VCC_RX	Supply	Receiver section supply voltage
26	n.c.	-	No connection
27	n.c.	-	No connection
28	VCC	Supply	ON/OFF logic supply voltage

Electrical Characteristics

These characteristics apply over these ranges of conditions (unless otherwise stated):

$T_{AMB} = -30^{\circ}\text{C}$ to $+85^{\circ}\text{C}$, $V_{CC} = 3.75 \pm 0.15\text{V}$ or $4.85 \pm 0.15\text{V}$ (see fig. 3 for test circuit).

DC Characteristics

Characteristic	Min	Typ	Max	Unit
Supply Currents				
Sleep PD1 = 0, PD2 = 0			0.11	mA
Standby PD1 = 1, PD2 = 0		6	8	mA
Transmit Set Up PD1 = 0, PD2 = 1		36	51	mA
Duplex PD1 = 1, PD2 = 1		48	63	mA
Input Levels				
PD1, PD2 High	1.9		3.1	V
PD1, PD2 Low	0		0.5	V
Mod Cntrl High	$V_{CC}/2 + 0.3$		V_{CC}	V
Mod Cntrl Low	0		$V_{CC}/2 - 0.3$	V
Ratio Sel High	$0.6V_{CC}$		V_{CC}	V
Ratio Sel Low	0		$0.4V_{CC}$	V
Input Currents				
PD1, PD2 High			40	μA
PD1, PD2 Low	-0.1		0.1	μA

Electrical Characteristics

These characteristics apply over these ranges of conditions (unless otherwise stated):

$T_{AMB} = -30^{\circ}\text{C}$ to $+85^{\circ}\text{C}$, $V_{CC} = 3.75 \pm 0.15\text{V}$ or $V_{CC} = 4.85 \pm 0.15\text{V}$ (see fig. 3 for test circuit).

AC Characteristics

Characteristic	Min	Typ	Max	Unit
TXOSC Output				
Differential Output	500			mV p-p
TxOsc Frequency	70		140	MHz
Frequency / Supply Sensitivity			75	kHz
Spurii > 700MHz			-40	dBc
Differential Output Capacitance			2	pF
External Tank Inductance f = 90MHz	82	100		nH
External Tank Inductance f = 122.5MHz	56	68		nH
Power up time (from standby)			65	μs
TXPA Output Signal				
Output Power (RL = 50 Ω)	0	3	6	dBm
Noise at $\Delta f = \pm 45$ MHz			-145	dBc/Hz
Noise at $\Delta f = \pm 25$ kHz			-100	dBc/Hz
Harmonic Content			-20	dBc
Spurious - Image			-10	dBc
Spurious (fVCO ± 2 faux)			-30	dBc
Spurious (fVCO ± 3 faux)			-25	dBc
Spurious ($\Delta f = 45\text{MHz} \pm 15$ kHz) except 2fVCO - 9faux			-105	dBc
Spurious 2fVCO - 9faux			-60	dBc
Spurii within 800 to 940 MHz (note1)			-70	dBc
Other Spurii except image			-30	dBc
Isolation TXPA off (PD2 = PD1 = 1)	55			dB
Power up time			25	μs
Isolation TXPA to RVCOIN	45			dB
Residual Modulation (note 2)			-40	dB
RVCOIN Input Signal				
Signal Level	-10			dBm
Input Impedance		50		Ω
Divider input frequency	800		1100	MHz
Upconverter input frequency	910		1040	MHz
Phase Noise $\Delta f = 45\text{MHz}$			-155	dBc/Hz
Phase Noise $\Delta f = 25\text{kHz}$			-117	dBc/Hz
Spurious - harmonic			-20	dBc
Spurious - non-harmonic			-80	dBc
Divider				
Differential Output Level	500	600		mV p-p
Output Rise / Fall time			15	ns
Mod Control Set up time	20			ns
Mod Control Hold time			1	ns

Notes:

1. Exceptions.

Harmonics of divider output -37dBc max applicable when fVCO = 975.1354 MHz Ratio = 65

10th Harmonic of faux -47dBc applicable when faux = 90MHz, fVCO = 989.9375MHz

2. Residual modulation referenced to a 1kHz signal giving 3kHz deviation. Measured with 750 μs de-emphasis and CCITT filter.

ACE9020

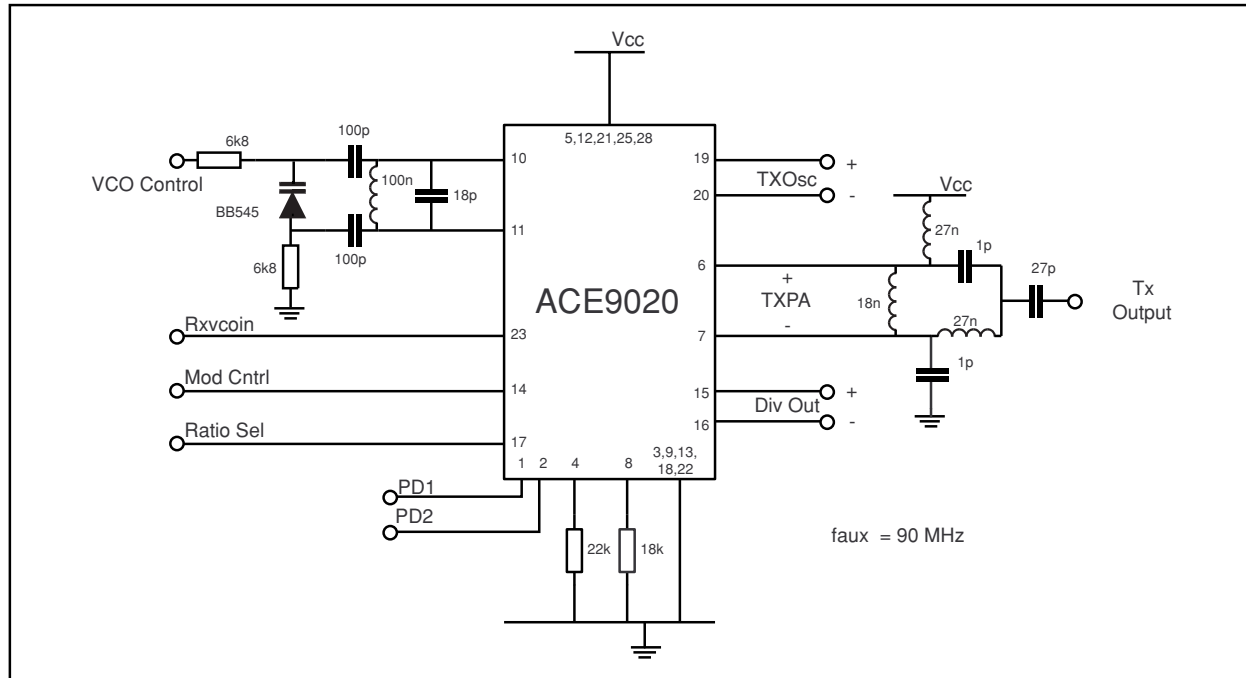

Figure 3 - ACE9020 Test circuit

Description

The ACE9020 is designed for use in a transceiver such as an analog cellular phone, which uses an offset modulation transmit architecture. The circuit consists of a VHF voltage controlled oscillator to generate the offset frequency, an upconverter to transmit frequency and also a prescaler for the main UHF phase locked loop. The Rxvcoin signal to the ACE9020 is normally the UHF local oscillator used for downconversion.

A basic block diagram is shown in fig. 2, further information on external connections is provided in the test circuit (fig. 3) and the applications diagram (fig. 4).

VHF Oscillator

This oscillator is a differential design which uses an external tank circuit as shown in fig. 3 and fig. 4. The components shown in fig. 3 give a VCO frequency of 90MHz. A varactor diode is coupled capacitively to the tank circuit; the anode is referenced to ground via a resistor. The VCO control from a synthesiser (eg ACE9030) charge pump output is applied to the cathode of the varactor also through a resistor. These resistors should be the same value to keep the differential circuit balanced. The VCO gain with the components shown will be typically 2 MHz/V. Modulation is applied to the anode via a resistive divider as shown in fig. 4; the actual signal applied to the varactor will be small as the frequency deviation will typically be a maximum of 12kHz in many applications. Differential buffered outputs from the oscillator (TXOSC) interface directly to the ACE9030 auxiliary synthesiser inputs.

Upconverter

An image reject mixer is used for the upconversion. This provides typically 20dB rejection of the unwanted upper sideband. The quadrature networks for the mixer are all provided on chip; this is optimised for UHF local oscillator and VHF offset oscillator frequencies typically used for analog cellular phones on the AMPS and TACS systems. Further

filtering of the TXPA output will be required to provide further suppression of the unwanted upper sideband, local oscillator signal and harmonics to meet cellular telephone specifications. SAW filters are available for the various transmit frequency bands.

The upconverter outputs (TXPA + and -) are differential current outputs. The use of differential outputs minimises current switching within the device and thus minimise crosstalk to other circuit blocks. The TXPA outputs must be matched to the external filter, normally 50Ω and single-ended. The network shown in fig. 3 provides a transformation from 400Ω differential to 50Ω single-ended and also provides dc bias from the Vcc supply to the open collector TXPA outputs. This network provides plus and minus 90° phase shift in each output which are then summed. Alternatively a Balun transformer could be used, it will again be necessary to provide dc bias to the TXPA outputs. The load to the current outputs should be maximised to obtain the maximum power output; 400Ω is an optimum figure as higher values require impractical component values for matching.

Prescaler

The two modulus prescaler is part of the UHF phase locked loop. It will typically be operating with ACE9030 radio interface and synthesiser. There is also a choice of divider ratio, set by the ratio select input as shown in table. 1, below.

	Ratio Sel = LOW	Ratio Sel = HIGH
Mod_Cntrl = LOW	÷129	÷65
Mod_Cntrl = HIGH	÷128	÷64

Table 1

The differential divider outputs can be directly coupled to the ACE9030 main synthesiser inputs.

Power Control Circuits

The inputs PD1 and PD2 are used to select the operating modes as shown below:

PD1	PD2	Mode	
0	0	Sleep	All circuits off
1	0	Standby	Prescaler On
1	1	Transmit Set Up	Prescaler, VHF oscillator on. Upconverter off
0	1	Duplex	All circuits on

The power down inputs (PD1, PD2) are compatible with ACE9030 digital outputs (DO5, 6, 7). These modes allow circuit operation and power consumption to be optimised. The ACE9020 can be put in sleep mode (0, 0) when the power consumption is minimal. The standby mode (1, 0) is used when the phone is in standby (receive only). The prescaler is operational to maintain the main UHF PLL; all circuitry associated with transmit functions is turned off.

There is an intermediate transmit set up state (1, 1). This allows the VHF oscillator and phase locked loop to stabilise before enabling the upconverter, preventing spurious transmissions. The time required for this state will be

determined primarily by the VHF PLL settling time. The power down inputs can then be set to (0, 1) the full duplex condition. The intermediate state should also be used during a 'handoff' during conversation on an analogue cellular phone, the VHF PLL continuing to operate while the main UHF PLL changes channel, the transmit output being disabled. It is also recommended that the intermediate state is used when going from duplex (0, 1) to standby (1, 0) modes.

Operating Notes

Good RF layout techniques should be used for this device to obtain optimum performance and also minimise crosstalk between circuit blocks. RF supply decoupling should be provided adjacent to Vcc pins; a value of 27pF is recommended.

Two external bias resistors are required. A 22kΩ resistor is connected from BIAS REF (Pin 4) to ground. This sets an accurate reference current for the chip. An 18k resistor is connected from RSET TXPA (Pin 8) to ground which controls the output level of the VHF oscillator and hence the TXPA output level.

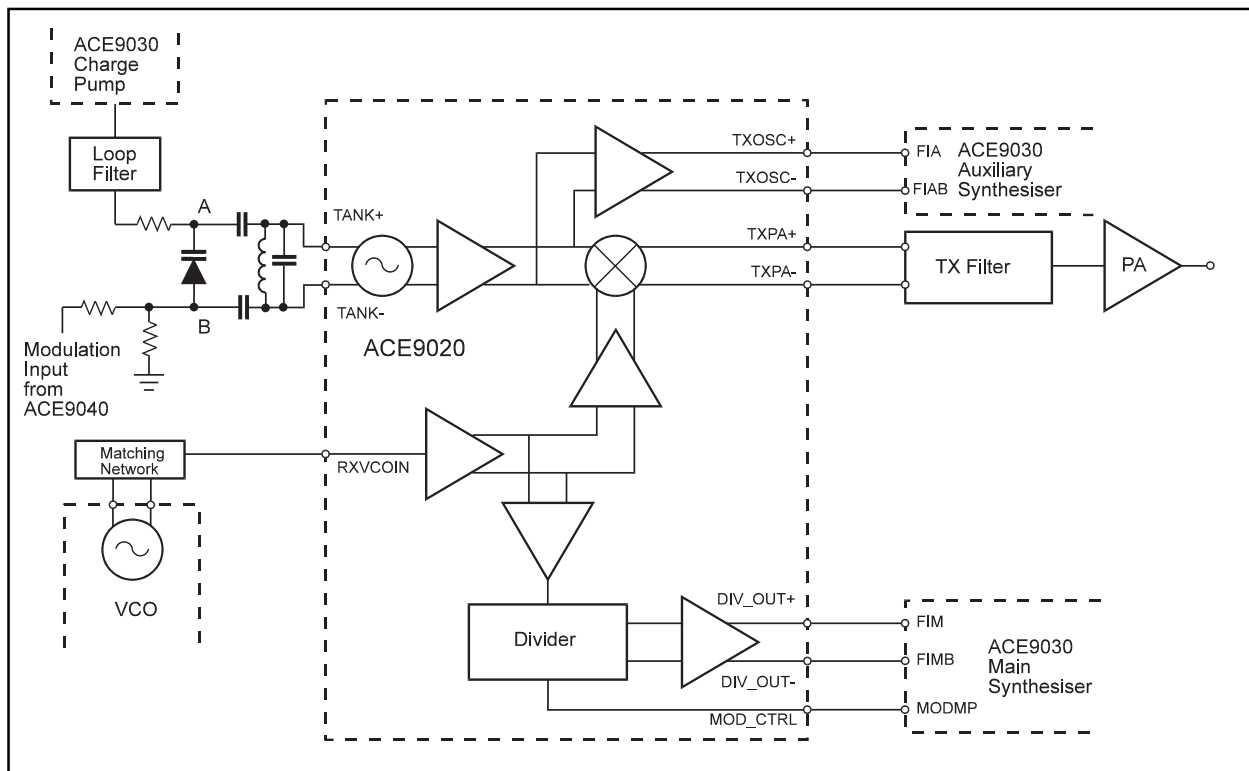

Figure 4 - Application Diagram



**For more information about all Zarlink products
visit our Web Site at
www.zarlink.com**

Information relating to products and services furnished herein by Zarlink Semiconductor Inc. or its subsidiaries (collectively "Zarlink") is believed to be reliable. However, Zarlink assumes no liability for errors that may appear in this publication, or for liability otherwise arising from the application or use of any such information, product or service or for any infringement of patents or other intellectual property rights owned by third parties which may result from such application or use. Neither the supply of such information or purchase of product or service conveys any license, either express or implied, under patents or other intellectual property rights owned by Zarlink or licensed from third parties by Zarlink, whatsoever. Purchasers of products are also hereby notified that the use of product in certain ways or in combination with Zarlink, or non-Zarlink furnished goods or services may infringe patents or other intellectual property rights owned by Zarlink.

This publication is issued to provide information only and (unless agreed by Zarlink in writing) may not be used, applied or reproduced for any purpose nor form part of any order or contract nor to be regarded as a representation relating to the products or services concerned. The products, their specifications, services and other information appearing in this publication are subject to change by Zarlink without notice. No warranty or guarantee express or implied is made regarding the capability, performance or suitability of any product or service. Information concerning possible methods of use is provided as a guide only and does not constitute any guarantee that such methods of use will be satisfactory in a specific piece of equipment. It is the user's responsibility to fully determine the performance and suitability of any equipment using such information and to ensure that any publication or data used is up to date and has not been superseded. Manufacturing does not necessarily include testing of all functions or parameters. These products are not suitable for use in any medical products whose failure to perform may result in significant injury or death to the user. All products and materials are sold and services provided subject to Zarlink's conditions of sale which are available on request.

Purchase of Zarlink's I²C components conveys a licence under the Philips I²C Patent rights to use these components in and I²C System, provided that the system conforms to the I²C Standard Specification as defined by Philips.

Zarlink, ZL and the Zarlink Semiconductor logo are trademarks of Zarlink Semiconductor Inc.

Copyright Zarlink Semiconductor Inc. All Rights Reserved.

TECHNICAL DOCUMENTATION - NOT FOR RESALE