

Description

The YB1200 family consists of a series of 150mA ultra-low-noise, low dropout (LDO) linear regulators especially designed for battery-powered RF and wireless applications. The YB1200 regulator achieves a low 250mV dropout at 150mA load current of 3.3V output, ultra-low output voltage noise of 15 μ Vrms and PSRR of 57dB at 1KHz.

The YB1200 regulators are also optimized to work with low-ESR and low cost ceramic capacitors reducing the amount of board space critical in hand-held devices. The YB1200 requires only 0.47 μ F output capacitor for stability with any load. The YB1200 consumes less than 1 μ A in shutdown mode.

Other features include high output voltage accuracy and current limiting protection. The YB1200 regulators are available in a tiny SC-70 / SC-82 package.

Features

- High Accuracy $\pm 2\%$
- Ultra-Low-Noise Low-Drop-Out Regulator with 1.8/2.5/2.6/2.8/3.0/3.3V Preset Outputs
- Stable with 0.47 μ F Ceramic Capacitor for Any Load
- Typical Output Current: 150mA
- Low Quiescent Current: $\sim 90\mu$ A
- 250mV Dropout at 150mA Load (3.3V)
- Only Need Input and Output Capacitors
- Power Saving Shutdown Mode ($< 1\mu$ A)
- Thermal Protection Shutdown
- Built-In Internal Soft-Start
- Output Short-circuit Current Limit Protection
- Green package (RoHS) available

Applications

- PDA, Palmtops and Notebook Computers
- DSC, Handset Camera Modules
- PCMCIA Cards, PC Cameras
- USB Based Portable Devices (MP3, PMP)
- GSM/GPRS/3G RF Transceiver Modules
- Wireless LANs, Bluetooth Portable Radios

Typical Application Circuit

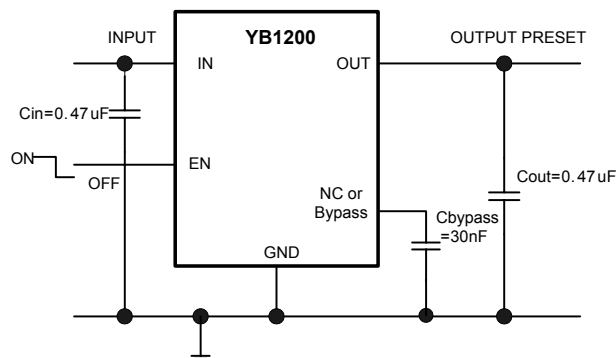

Figure 1-1. SC-70 application circuit

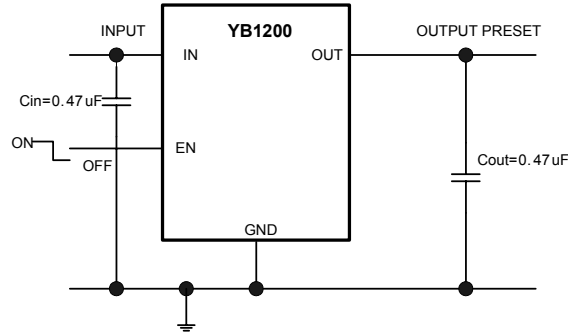

Figure 1-2. SC-82 application circuit

Pin Configuration

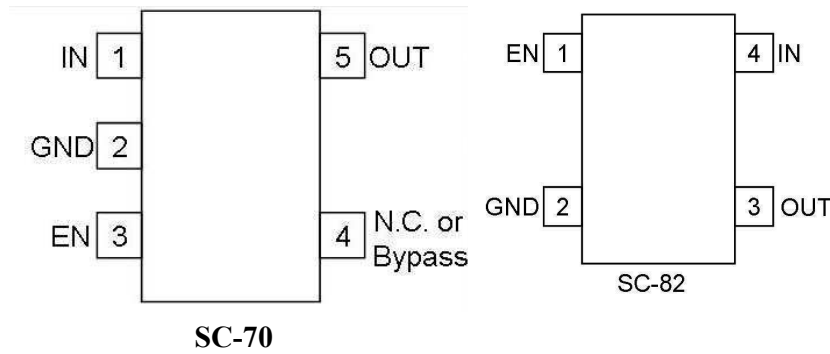

Figure 2. Pin configuration

Pin Description

Table 1

Pin	Name	SC-70 Description
1	IN	Unregulated Input Supply.
2	GND	Ground pin.
3	EN	Pull high to enable the regulator.
4	N.C. Bypass	No external connection needed for normal operation. Noise Bypass for Ultra-Low-Noise Operation by connecting a 30nF capacitor from Bypass to GND.
5	OUT	Regulated Output Voltage. Bypass with a capacitor to GND.
Pin	Name	SC-82 Description
1	EN	Pull high to enable the regulator.
2	GND	Ground pin.
3	OUT	Regulated Output Voltage.
4	IN	Unregulated Input Supply.

Ordering Information

Table 2

YB1200 Order Information				
Output Voltage	Grade	Order Information	Package Marking	Supplied as:
SC70-5 Small Package				
1.8	Green Package+ Standard	YB1200SC70S-1.8G	BA	3000 Units Tape & Reel
2.5	Green Package+ Standard	YB1200SC70S-2.5G	BB	3000 Units Tape & Reel
2.6	Green Package+ Standard	YB1200SC70S-2.6G	BE	3000 Units Tape & Reel
2.8	Green Package+ Standard	YB1200SC70S-2.8G	BC	3000 Units Tape & Reel
3.0	Green Package+ Standard	YB1200SC70S-3.0G	BF	3000 Units Tape & Reel
3.3	Green Package+ Standard	YB1200SC70S-3.3G	BD	3000 Units Tape & Reel
SC-82 Small Package				
1.8	Green Package+ Standard	YB1200SC82S-1.8G	DA	3000 Units Tape & Reel
2.5	Green Package+ Standard	YB1200SC82S-2.5G	DB	3000 Units Tape & Reel
2.6	Green Package+ Standard	YB1200SC82S-2.6G	DE	3000 Units Tape & Reel
2.8	Green Package+ Standard	YB1200SC82S-2.8G	DC	3000 Units Tape & Reel
3.0	Green Package+ Standard	YB1200SC82S-3.0G	DF	3000 Units Tape & Reel
3.3	Green Package+ Standard	YB1200SC82S-3.3G	DD	3000 Units Tape & Reel

Absolute Maximum Ratings

Supply Voltage -0.3V to 7.0V
 Output Voltage -0.3V to ($V_{IN}+0.3V$)
 Output Short-Circuit Duration Infinite
 Junction Temperature Range +150°C
 Storage Temperature Range -65°C to +150°C
 Lead Temperature +250°C
 Thermal Resistance (SC-70/82, θ_{JA}) 330°C/W
 Internal Power Dissipation (SC-70/82, PD) 0.3W

Recommended Operating Conditions

Input Supply Voltage 2V to 6.0V
 Operating Temperature -40°C to +85°C
 ESD Susceptibility (HBM) 2KV
 ESD Susceptibility (MM) 200V

Electrical Characteristics

Table 3 $T_A = 25^\circ\text{C}$, $V_{IN} = (V_{OUT} + 1V)$, $C_{IN} = C_{OUT} = 0.47\mu\text{F}$, $V_{EN} = V_{IN}$

Function Parameter	Conditions	Min	Typ	Max	Units
Input Voltage Range		2.0		6.0	V
Output Voltage	Predefined (metal masks)	1.8		3.3	V
Output Voltage Accuracy	$I_{OUT} = 10\text{mA}$	-2.0		+2.0	%
Output Current Limit	Short-circuit output		200		mA
Dropout Voltage (See Note 1)	$V_{OUT} = 3.3V, I_{OUT} = 150\text{mA}$		250		mV
	$V_{OUT} = 3.0V, I_{OUT} = 150\text{mA}$		275		
	$V_{OUT} = 2.8V, I_{OUT} = 150\text{mA}$		300		
	$V_{OUT} = 2.6V, I_{OUT} = 150\text{mA}$		310		
	$V_{OUT} = 2.5V, I_{OUT} = 150\text{mA}$		320		
	$V_{OUT} = 1.8V, I_{OUT} = 150\text{mA}$		500		
Ground Current	$I_{OUT} = 0\text{mA}$		90		μA
Line Regulation	$V_{IN} = (V_{OUT} + 1V)$ to 6.0V, $I_{OUT} = 10\text{mA}$		0.3		%/V
Load Regulation	$I_{OUT} = 1\text{mA}$ to 150mA		1.2		%
Shutdown Supply Current	EN=0V		~0.01		μA

Ripple Rejection (PSRR)	f = 100Hz, I _{OUT} =1mA		52		dB
	f = 1KHz, I _{OUT} =1mA		55		
	f = 10KHz, I _{OUT} =1mA		53		
Output Noise Voltage	f = 100Hz to 100KHz, I _{load} =10mA, Bypass=0nF		45		μVrms
	f = 100Hz to 100KHz, I _{load} =10mA, Bypass=30nF		15		μVrms
Shutdown Exit Delay (See Note 2)	R _{load} =50ohm		45	300	μs
EN Logic Low Level	V _{IN} =2.0V to 5.5V			0.4	V
EN Logic High Level	V _{IN} =2.0V to 5.5V	1.2		V _{IN}	V
EN Input Bias Current	V _{IN} =5.5V, EN=0V or 6V		0.01		μA
Thermal Shutdown	Shutdown Temperature		160		°C
Thermal-Shutdown hysteresis			20		°C

Note 1 : The drop out voltage varies depending on output voltage selection

Dropout is defined as V_{IN} – V_{OUT} when V_{OUT} is 100mV below V_{OUT} where V_{in}=V_{out} +1V for nominal V_{OUT}.

Note 2: Time needed for V_{OUT} to reach 90% of final value.

Typical Characteristics

At T_A = 25°C, V_{IN} = (V_{OUT} + 1V), C_{IN} = C_{OUT} = 0.47μF, V_{EN} = V_{IN}, unless otherwise noted.

Dropout Voltage vs Load Current

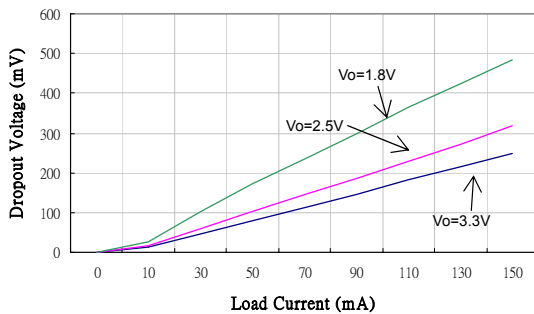

Dropout Voltage vs Temperature

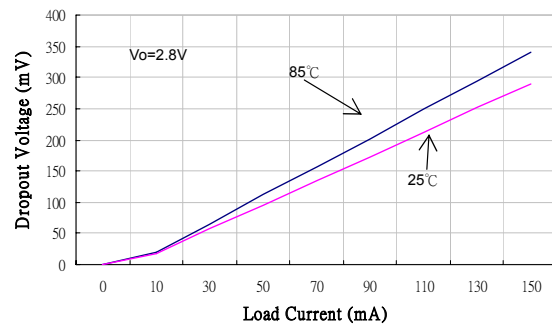

PSRR vs Frequency (Load=1mA)

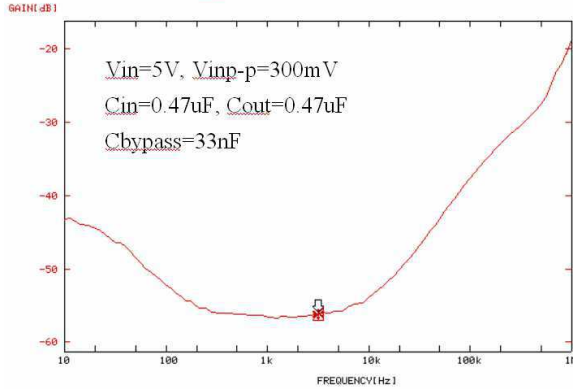

PSRR vs Frequency (Load=10mA)

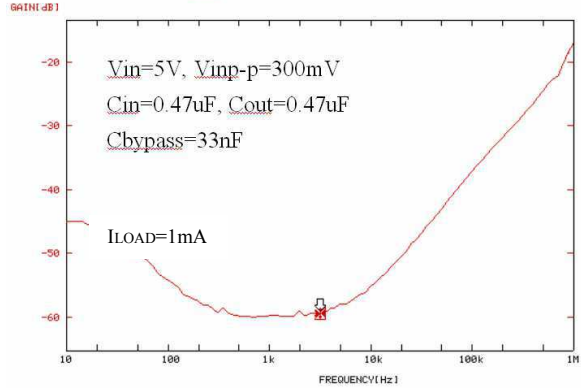

PSRR vs Frequency (Load=100mA)

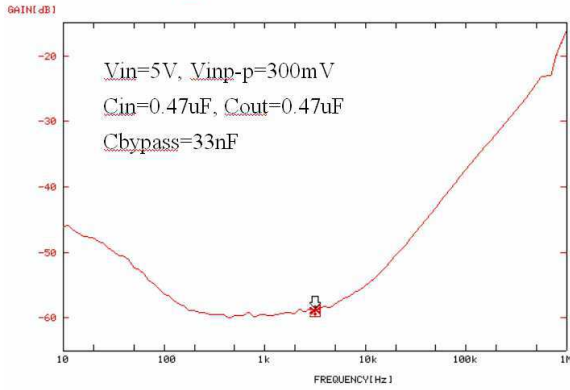

Output Voltage vs. Temperature

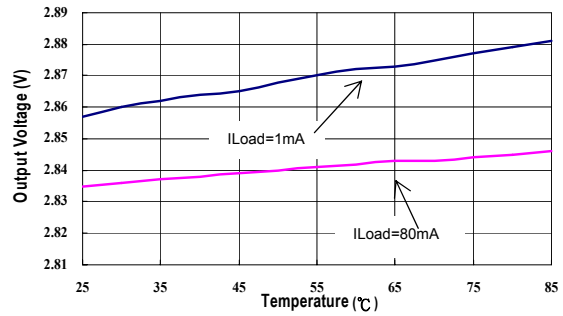

Ground Current vs. Input Voltage

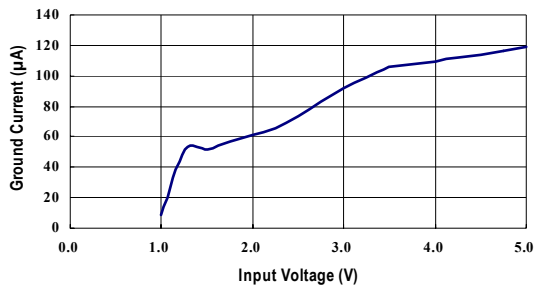

Shutdown Exit Delay

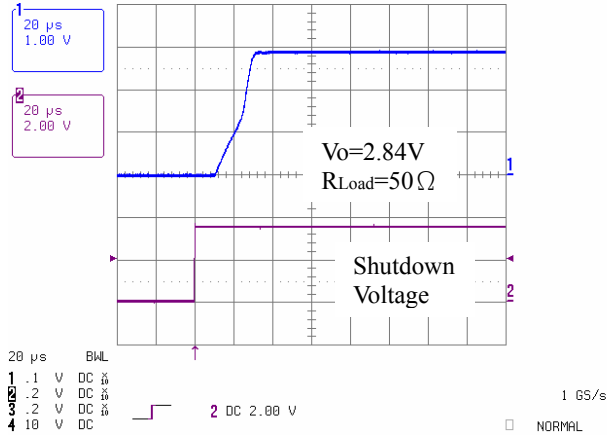

Shutdown Delay

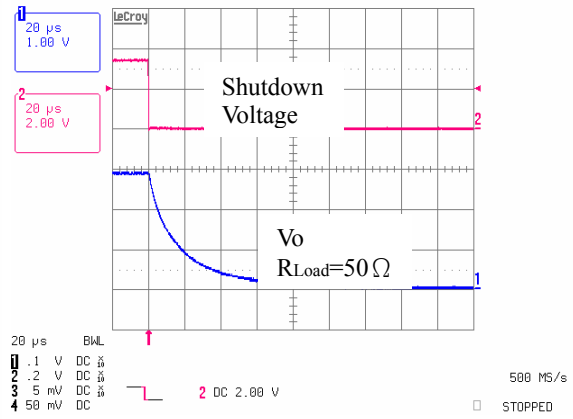

Line Transient Response

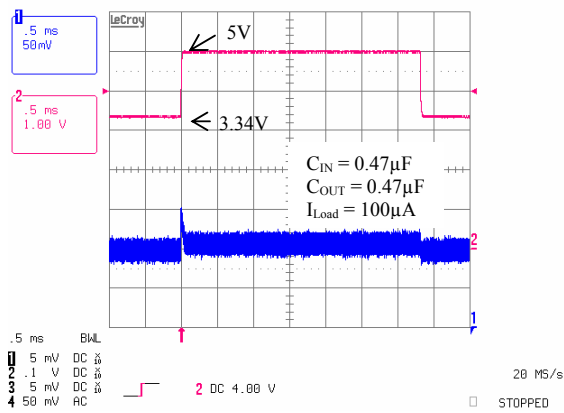

Load Transient Response

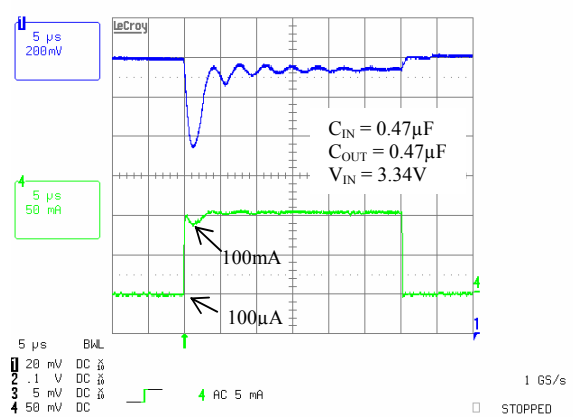

Functional Block Diagram

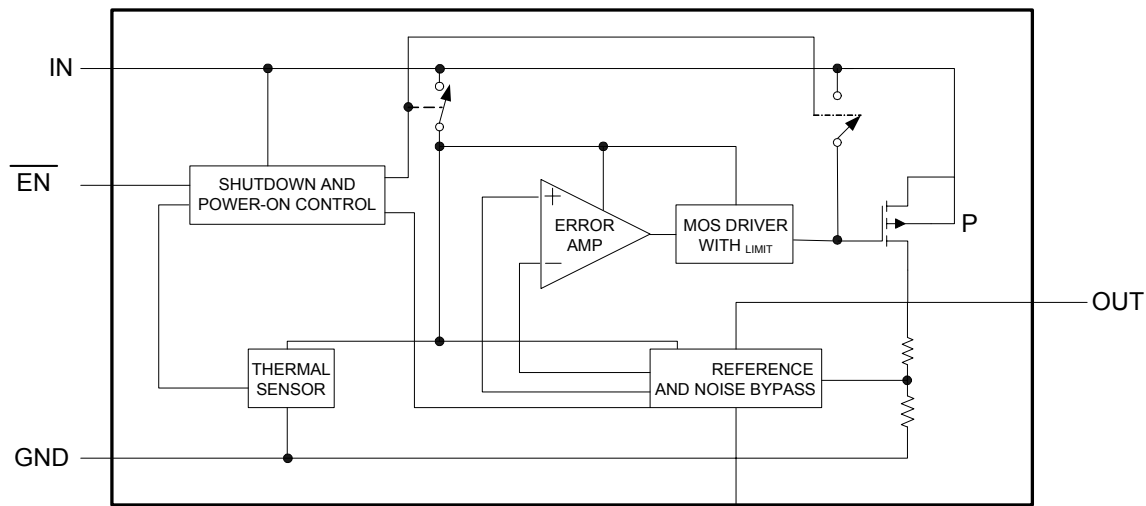

Figure 3. Block Diagram

Functional Description

The YB1200 is an ultra-low-noise, low-quiescent current, low-dropout linear regulator. It is supplied in a SC-70 and SC-82 package for space and noise sensitive applications. These devices can supply loads up to 150mA. As shown in the *Functional Block Diagram*, the YB1200 consists of a reference and noise bypass circuit, error amplifier, output drive transistor, internal feedback voltage divider, thermal sensor, and short circuit current limiter. The internal reference is connected to the error amplifier's inverting input. The error amplifier compares this reference with the feedback voltage and amplifies the difference. If the feedback voltage is lower than the reference voltage, the pass-transistor gate is pulled low. This allows more current to pass to the output and increases the output voltage. If the feedback voltage is too high, the pass

transistor gate is pulled high, allowing less current to pass to the output. The parts are available with preset output voltages ranging from 1.8V to 3.3V.

Stability

The YB1200 is a high performance LDO emphasizing stability with low output capacitance. It is able to maintain stability with an output capacitor as low as 0.47uF. The output capacitor can also be increased to optimize performance. The YB1200 will remain stable and in regulation with no load, unlike many other voltage regulators.

Internal P-Channel Pass Transistor

The YB1200 features a low impedance P-channel MOSFET pass transistor. This provides several advantages over similar designs using a PNP pass transistor, including low operating power and longer

battery life. The YB1200 consumes only 90 μ A of quiescent current under most conditions.

Output Short-Circuit Current Limit

The YB1200 includes a current limiter, which monitors and controls the pass transistor's gate voltage, limiting the output current to about 200 mA, for example, in a short-circuit output situation.

Shutdown

The YB1200 also features a low-power active shutdown mode. It has a switch that turns off the device when disabled. This allows the output capacitor and load to discharge and de-energize the load. In the shutdown mode, the internal functional blocks, such as voltage reference and the error amplifier, are turned off completely, and the quiescent current is less than 1 μ A.

Thermal Protection Shutdown

The thermal protection shutdown function protects the device from operating in over temperature condition. When the junction temperature exceeds +160 $^{\circ}$ C, the thermal sensor signals the shutdown logic, turning off the pass transistor and allowing the IC to cool down. The thermal sensor turns the pass transistor on again after the IC's junction temperature drops to +140 $^{\circ}$ C.

Soft-Start Circuitry

The YB1200 includes a soft-start circuitry to limit inrush current at turn-on. During power up, the output capacitor and output load are charged with a reduced output current.

Shortly after the initial power up, the soft-start feature is terminated and normal operation is resumed.

Application Information

Enable/Shutdown

The YB1200 comes with an active-high enable pin that allows the regulator to be enabled. Forcing the enable pin low disables the regulator and puts it into the shutdown mode. This pin cannot be left floating as it may cause an undetermined state.

Input/Output Capacitor

It is recommended to use a 0.47 μ F capacitor on the YB1200 input and a 0.47 μ F capacitor on the output. For high regulation performance, larger input capacitor values and lower ESRs provide better noise rejection and line-transient response. The output noise, load-transient response, stability, and power-supply rejection can be improved by using large output capacitors. Low ESR ceramic capacitors provide optimal performance and save space.

Power Supply Rejection and Transient Response

The PSRR and transient response can be improved by increasing the values of the input and output bypass capacitors, and through passive filtering techniques.

SC-70 Package Information

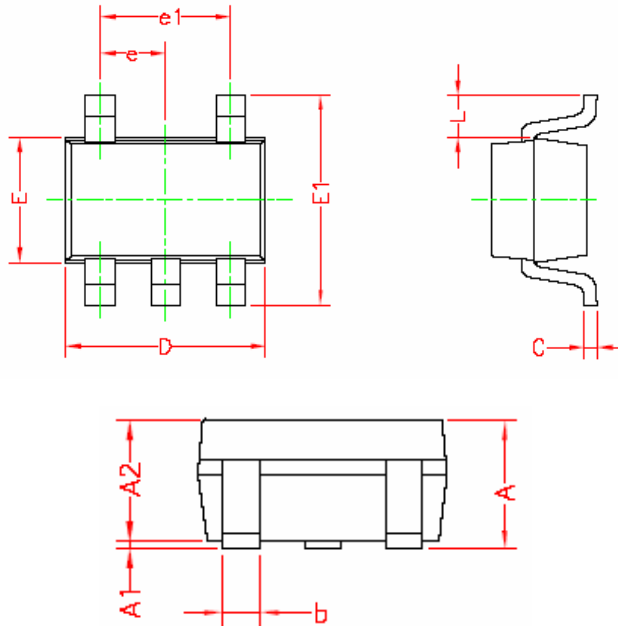

Symbol	Millimeters		Inches	
	MIN.	MAX.	MIN.	MAX.
A	0.90	1.10	.036	0.44
A1	0.025	0.10	.001	.004
A2	0.875	1.00	.035	.040
b	0.20	0.40	.008	.016
C	0.10	0.15	.004	.006
D	1.90	2.10	.076	.084
E	1.15	1.35	.046	.054
E1	2.00	2.20	.080	.088
e	0.65 BSC.		.026 BSC.	
e1	1.30 BSC.		.052 BSC.	
L	0.425 REF.		.017 REF.	

Note:

1. All dimensions are in millimeters, and the dimensions in inches are for reference only.
2. 1mm=40mils=0.04inches

SC-82 Package Information

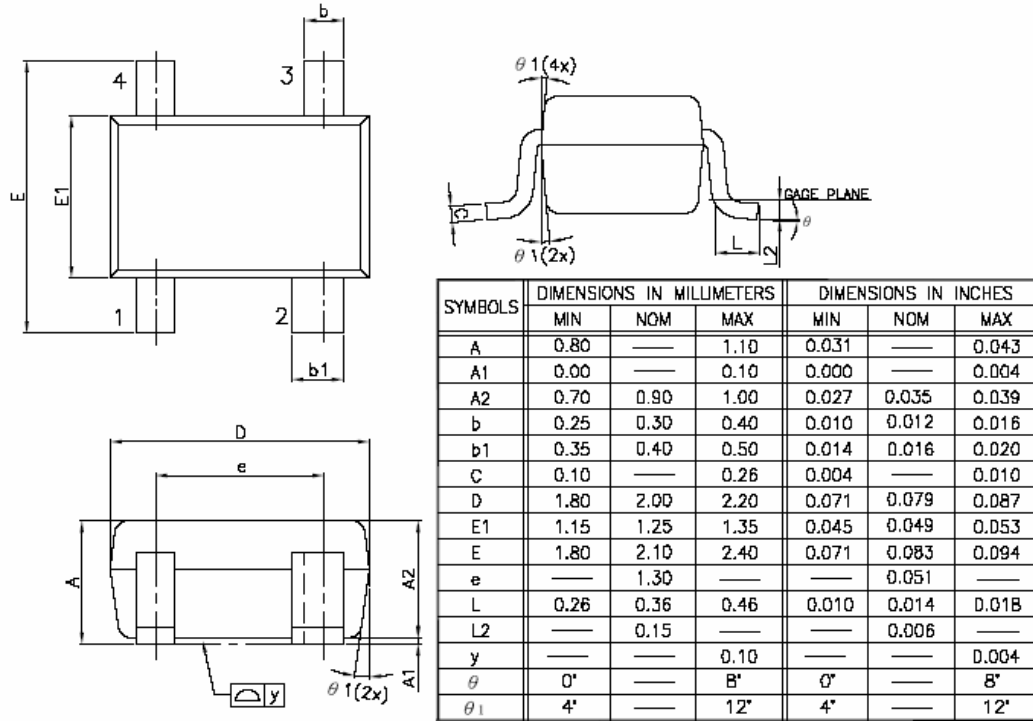

NOTE:

1. CONTROLUNG DIMENSION: mm
2. LEAD FRAME MATERIAL:EFTEC-64T 1/2H OR H.
3. DIMENSION D DOES NOT INCLUDE MOLD FLASH, PROTRUSIONS OR GATE BURRS, MOLD FLASH/PROTRUSIONS OR GATE BURRS SHALL NOT EXCEED 0.15 mm PER SIDE,
4. DIMENSION E1 DOES NOT INCLUDE INTERLEAD FLASH OR PROTRUSION. INTERLEAD FLASH OR PROTRUSION SHALL NOT EXCEED 0.15mm PER SIDE.