



## 12-Bit, 31-MSPS, Dual-Channel CCD ANALOG FRONT-END FOR DIGITAL COPIERS

### FEATURES

- **Dual-Channel CCD Processing:**
  - Correlated Double Sampler (CDS)
  - Sample-and-Hold Mode (S/H)
  - Digital Programmable Amplifier
  - CCD Offset Correction (OB Loop)
- **High-Performance ADC:**
  - 12-Bit Resolution
  - INL:  $\pm 2$  LSB
  - DNL:  $\pm 0.5$  LSB
  - No Missing Codes Ensured
- **High-Speed Operation:**
  - Sample Rate: 31 MHz (max, Design Ensured)
  - 78-dB SNR (at 0-dB Gain)
- **Low-Power Consumption:**
  - Low Voltage: 3.0 V to 3.6 V
  - Low Power: 290 mW (typ at 3.3 V)
  - Standby Mode: 20 mW (typ)

### APPLICATIONS

- Copiers
- Scanners
- Facsimiles

### DESCRIPTION

The VSP5010 is a complete application-specific standard product (ASP) for charge-coupled device (CCD) line sensor applications such as copiers, scanners, and facsimiles. The VSP5010 provides two independent line-processing channels, and performs analog front-end (AFE) data processing and analog-to-digital conversion. Each channel features correlated double sampling (CDS) and sample-and-hold (S/H) processing stages, 14 analog-to-digital converter (ADC) blocks, a digital programmable gain amplifier (DPGA), and an optical black (OB) correction loop. Data are output in a 12-bit word; two-channel ADC data are multiplexed and then output.

The VSP5010 operates from a single 3.3-V supply. The device is available in an LQFP-64 package.

PRODUCTPREVIEW



Please be aware that an important notice concerning availability, standard warranty, and use in critical applications of Texas Instruments semiconductor products and disclaimers thereto appears at the end of this data sheet.

All trademarks are the property of their respective owners.

PRODUCT PREVIEW information concerns products in the formative or design phase of development. Characteristic data and other specifications are design goals. Texas Instruments reserves the right to change or discontinue these products without notice.

Copyright © 2008, Texas Instruments Incorporated



This integrated circuit can be damaged by ESD. Texas Instruments recommends that all integrated circuits be handled with appropriate precautions. Failure to observe proper handling and installation procedures can cause damage.

ESD damage can range from subtle performance degradation to complete device failure. Precision integrated circuits may be more susceptible to damage because very small parametric changes could cause the device not to meet its published specifications.

### PACKAGE/ORDERING INFORMATION<sup>(1)</sup>

| PRODUCT   | PACKAGE-LEAD | PACKAGE DESIGNATOR | SPECIFIED TEMPERATURE RANGE | PACKAGE MARKING | ORDERING NUMBER | TRANSPORT MEDIA, QUANTITY |
|-----------|--------------|--------------------|-----------------------------|-----------------|-----------------|---------------------------|
| VSP5010PM | LQFP-64      | PM                 | –25°C to +85°C              | VSP5010PM       | VSP5010PM       | Tray, 160 Pieces          |
|           |              |                    |                             |                 | VSP5010PMR      | Tape and Reel, 1000       |

(1) For the most current package and ordering information see the Package Option Addendum at the end of this document, or see the TI web site at [www.ti.com](http://www.ti.com).

### ABSOLUTE MAXIMUM RATINGS<sup>(1)</sup>

Over operating free-air temperature range (unless otherwise noted).

|                                                        | VSP5010    | UNIT                |
|--------------------------------------------------------|------------|---------------------|
| Supply voltage                                         | VCC, VDD   | +4.0                |
| Supply voltage differences                             | VCC, VDD   | ±0.1                |
| Ground voltage differences                             | AGND, DGND | ±0.1                |
| Digital input voltage                                  |            | –0.3 to (VDD + 0.3) |
| Analog input voltage                                   |            | –0.3 to (VCC + 0.3) |
| Input current (all pins except supplies)               |            | ±10                 |
| Ambient temperature under bias                         |            | –40 to +125         |
| Storage temperature                                    |            | –55 to +150         |
| Junction temperature                                   |            | +150                |
| Lead temperature (soldering, 5s)                       |            | +260                |
| Package temperature (I <sub>R</sub> reflow, peak, 10s) |            | +235                |

(1) Stresses beyond those listed under absolute maximum ratings may cause permanent damage to the device. Exposure to absolute-maximum-rated conditions for extended periods may affect device reliability. These are stress ratings only and functional operation of the device at these or any other conditions beyond those indicated under recommended operating conditions is not implied.

### RECOMMENDED OPERATING CONDITIONS

Over operating free-air temperature range, unless otherwise noted.

|                                                | MIN          | NOM | MAX  | UNIT |     |
|------------------------------------------------|--------------|-----|------|------|-----|
| Analog supply voltage                          | VCC          | 3   | 3.3  | 3.6  | V   |
| Digital supply voltage                         | VDD          | 3   | 3.3  | 3.6  | V   |
| Analog input voltage, full-scale (0 dB)        |              |     | 1    |      |     |
| Digital input logic family                     |              |     | CMOS |      |     |
| Digital input clock frequency                  | System clock | 10  |      | 30   | MHz |
| Digital output load capacitance                |              |     | 30   |      | pF  |
| Operating free-air temperature, T <sub>A</sub> |              | –25 |      | +85  | °C  |

## ELECTRICAL CHARACTERISTICS

Over operating free-air temperature range, unless otherwise noted.

| PARAMETER                                            | TEST CONDITIONS                   | VSP5010PM                                    |                 |                | UNIT             |
|------------------------------------------------------|-----------------------------------|----------------------------------------------|-----------------|----------------|------------------|
|                                                      |                                   | MIN                                          | TYP             | MAX            |                  |
| <b>RESOLUTION</b>                                    |                                   |                                              |                 |                |                  |
| Resolution                                           |                                   |                                              | 12              |                | Bits             |
| <b>SIGNAL PASS</b>                                   |                                   |                                              |                 |                |                  |
| Signal pass                                          |                                   |                                              | 2               |                | Channels         |
| <b>MAXIMUM CONVERSION RATE</b>                       |                                   |                                              |                 |                |                  |
| Maximum conversion rate                              |                                   |                                              | 30              |                | MHz              |
| <b>DIGITAL INPUT</b>                                 |                                   |                                              |                 |                |                  |
| Input voltage                                        | $V_{T+}$                          | Positive-going threshold                     |                 | 1.8            | V                |
|                                                      | $V_{T-}$                          | Negative-going threshold                     |                 | 1.1            | V                |
| Input current                                        | $I_{IH}$                          | Logic high, $V_{IN} = +3$ V                  |                 |                | $\pm 20$ $\mu$ A |
|                                                      | $I_{IL}$                          | Logic low, $V_{IN} = 0$ V                    |                 |                | $\pm 20$ $\mu$ A |
| Input limit                                          |                                   |                                              | -0.3            | $V_{CC} + 0.3$ | V                |
| SYSCLK clock duty cycle                              |                                   |                                              | 50              |                | %                |
| Input capacitance                                    |                                   |                                              | 5               |                | pF               |
| <b>DIGITAL OUTPUT (Even Channel and Odd Channel)</b> |                                   |                                              |                 |                |                  |
| Logic family                                         |                                   |                                              | CMOS            |                |                  |
| Logic coding                                         |                                   |                                              | Straight Binary |                |                  |
| Multiplexing frequency                               |                                   |                                              | 60              |                | MHz              |
| Output voltage                                       | $V_{OH}$                          | Logic high, $I_{OH} = -2$ mA                 | 2.5             |                | V                |
|                                                      | $V_{OL}$                          | Logic low, $I_{OL} = 2$ mA                   |                 | 0.4            | V                |
| <b>ANALOG INPUT (CCDIN)</b>                          |                                   |                                              |                 |                |                  |
| Input level for full-scale output                    |                                   | DPGA gain = 0 dB                             | 1400            |                | mV               |
| Allowable feed-through level                         |                                   |                                              | 1.0             |                | V                |
| Input capacitance                                    |                                   |                                              | 15              |                | pF               |
| Input limit                                          |                                   |                                              | -0.3            | 3.6            | V                |
| <b>TRANSFER CHARACTERISTICS</b>                      |                                   |                                              |                 |                |                  |
| Differential nonlinearity (DNL)                      | CDS mode = 0 dB, DPGA gain = 0 dB |                                              |                 | $\pm 0.5$      | $\pm 1$ LSB      |
|                                                      | SH mode, DPGA gain = 0 dB         |                                              |                 | $\pm 0.5$      | $\pm 1$ LSB      |
| Integral nonlinearity (INL)                          | CDS mode = 0 dB, DPGA gain = 0 dB |                                              |                 | $\pm 2$        | $\pm 4$ LSB      |
|                                                      | SH mode, DPGA gain = 0 dB         |                                              |                 | $\pm 4$        | LSB              |
| No missing codes                                     |                                   | DPGA gain = 0 dB                             | Ensured         |                |                  |
| Step input settling time                             |                                   | Full-scale step input                        |                 | 1              | Pixel            |
| Overload recovery time                               |                                   | Step input from 2.0 V to 0 V                 |                 | 2              | Pixels           |
| Data latency                                         |                                   |                                              |                 | 9<br>(fixed)   | Clocks           |
| Signal-to-noise ratio <sup>(1)</sup>                 | DPGA gain = 0 dB                  |                                              |                 | 78             | dB               |
|                                                      | DPGA gain = +24 dB                |                                              |                 | 54             | dB               |
| Channel mismatch                                     |                                   |                                              |                 | $\pm 3$        | %                |
| <b>CORRELATED DOUBLE SAMPLER (CDS)</b>               |                                   |                                              |                 |                |                  |
| Reference level sample settling time                 |                                   | Within 1 LSB, driver impedance = 50 $\Omega$ |                 | 8.3            | ns               |
| Data level sample settling time                      |                                   | Within 1 LSB, driver impedance = 50 $\Omega$ |                 | 83             | ns               |

(1) SNR = 20 log (16384/output rms noise in LSB), input connected to ground through capacitor.

**PRODUCT PREVIEW**

**ELECTRICAL CHARACTERISTICS (continued)**

Over operating free-air temperature range, unless otherwise noted.

| PARAMETER                                    | TEST CONDITIONS                                                           | VSP5010PM       |            |      | UNIT                 |
|----------------------------------------------|---------------------------------------------------------------------------|-----------------|------------|------|----------------------|
|                                              |                                                                           | MIN             | TYP        | MAX  |                      |
| <b>INPUT CLAMP</b>                           |                                                                           |                 |            |      |                      |
| Clamp-on resistance                          |                                                                           |                 | 400        |      | $\Omega$             |
| Clamp level                                  |                                                                           |                 | 1.5        |      | V                    |
| <b>OB CLAMP LOOP</b>                         |                                                                           |                 |            |      |                      |
| CCD offset correction range                  |                                                                           | –300            |            | 300  | mV                   |
| DAC resolution                               |                                                                           |                 | 10         |      | Bits                 |
| Minimum DAC output current                   | COB pin                                                                   |                 | $\pm 0.15$ |      | $\mu\text{A}$        |
| Maximum DAC output current                   | COB pin                                                                   |                 | $\pm 153$  |      | $\mu\text{A}$        |
| Loop time constant                           | $C_{\text{COB}} = 0.1 \mu\text{F}$                                        |                 | 40.7       |      | $\mu\text{s}$        |
| Slew rate                                    | $C_{\text{COB}} = 0.1 \mu\text{F}$ , at current DAC full-scale output     |                 | 1530       |      | V/s                  |
| Optical black clamp level                    | Program range                                                             | 0               |            | 510  | LSB                  |
|                                              | OB clamp code = 0101 0000b                                                |                 | 160        |      | LSB                  |
| <b>REFERENCE</b>                             |                                                                           |                 |            |      |                      |
| Positive reference voltage                   |                                                                           |                 | 1.85       |      | V                    |
| Negative reference voltage                   |                                                                           |                 | 1.1        |      | V                    |
| <b>DIGITAL PROGRAMMABLE AMPLIFIER (DPGA)</b> |                                                                           |                 |            |      |                      |
| Gain program resolution                      |                                                                           |                 | 10         |      | Bits                 |
| Gain                                         | Gain code = 11 1111 1111b                                                 | 24 dB           |            | 16   | V/V                  |
|                                              | Gain code = 10 0000 0000b                                                 | 18 dB           |            | 8    | V/V                  |
|                                              | Gain code = 00 0100 0000b                                                 | 0 dB            |            | 1    | V/V                  |
|                                              | Gain code = 00 0000 0000b                                                 | —               |            | 0    | V/V                  |
| Gain error                                   |                                                                           |                 | $\pm 0.5$  |      | dB                   |
| <b>SERIAL INTERFACE</b>                      |                                                                           |                 |            |      |                      |
| Data length                                  | Chip address = 2 bits, register address = 4 bits,<br>and data = 10 bits   |                 | 2          |      | Bytes                |
| Serial clock frequency                       |                                                                           |                 |            | 10   | MHz                  |
| <b>POWER SUPPLY</b>                          |                                                                           |                 |            |      |                      |
| Supply voltage                               | VCC, VDD                                                                  | 3.0             | 3.3        | 3.6  | V                    |
| Power dissipation                            | VCC = VDD = 3.3 V, $f_{\text{SYSCLK}} = 30 \text{ MHz}$ ,<br>load = 10 pF |                 | 290        |      | mW                   |
|                                              | Standby mode                                                              |                 | 20         |      | mW                   |
| <b>TEMPERATURE RANGE</b>                     |                                                                           |                 |            |      |                      |
| Operation temperature                        |                                                                           | –25             |            | +85  | $^{\circ}\text{C}$   |
| Storage temperature                          |                                                                           | –55             |            | +125 | $^{\circ}\text{C}$   |
| Thermal resistance                           | $\theta_{\text{JA}}$                                                      | LQFP-64 package |            | 83   | $^{\circ}\text{C/W}$ |

PIN CONFIGURATION

VSP5010PM  
LQFP-64  
(TOP VIEW)

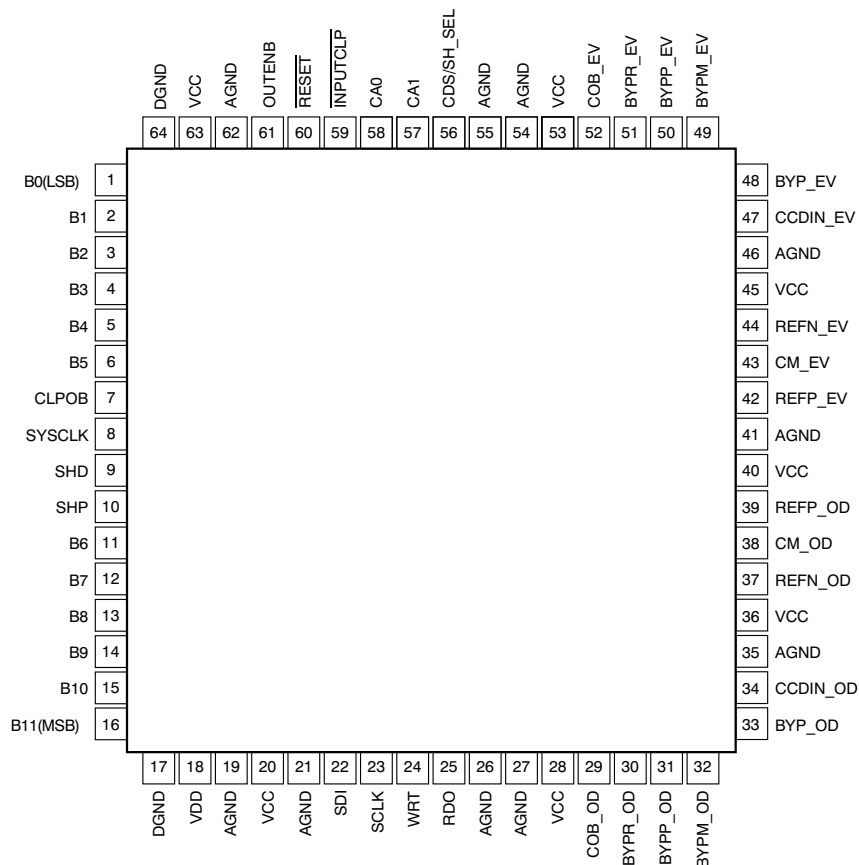

Table 1. TERMINAL FUNCTIONS

| TERMINAL  |     | TYPE <sup>(1)</sup> | DESCRIPTION                                 |
|-----------|-----|---------------------|---------------------------------------------|
| NAME      | NO. |                     |                                             |
| B0 (LSB)  | 1   | DO                  | ADC output, bit 0 (least significant bit)   |
| B1        | 2   | DO                  | ADC output, bit 1                           |
| B2        | 3   | DO                  | ADC output, bit 2                           |
| B3        | 4   | DO                  | ADC output, bit 3                           |
| B4        | 5   | DO                  | ADC output, bit 4                           |
| B5        | 6   | DO                  | ADC output, bit 5                           |
| CLPOB     | 7   | DI                  | Optical black clamp pulse                   |
| SYSCLK    | 8   | DI                  | System clock input                          |
| SHD       | 9   | DI                  | CCD data sampling pulse                     |
| SHP       | 10  | DI                  | CCD reference sampling pulse                |
| B6        | 11  | DO                  | ADC output, bit 6                           |
| B7        | 12  | DO                  | ADC output, bit 7                           |
| B8        | 13  | DO                  | ADC output, bit 8                           |
| B9        | 14  | DO                  | ADC output, bit 9                           |
| B10       | 15  | DO                  | ADC output, bit 10                          |
| B11 (MSB) | 16  | DO                  | ADC output, bit 11 (most significant bit)   |
| DGND      | 17  | P                   | Digital ground for digital outputs (B0–B11) |

(1) Designators in TYPE: P = power supply and ground; DI = digital input; DO = digital output; AI = analog input; and AO = analog output.

**Table 1. TERMINAL FUNCTIONS (continued)**

| TERMINAL                     |     | TYPE <sup>(1)</sup> | DESCRIPTION                                                                               |
|------------------------------|-----|---------------------|-------------------------------------------------------------------------------------------|
| NAME                         | NO. |                     |                                                                                           |
| VDD                          | 18  | P                   | Digital supply for digital outputs (B0–B11)                                               |
| AGND                         | 19  | P                   | Analog ground                                                                             |
| VCC                          | 20  | DI                  | Analog power supply                                                                       |
| AGND                         | 21  | DI                  | Analog ground                                                                             |
| SDI                          | 22  | DI                  | Serial interface data input                                                               |
| SCLK                         | 23  | DI                  | Serial interface data shift clock (rising edge trigger)                                   |
| WRT                          | 24  | DI                  | Serial interface data write pulse (rising edge trigger)                                   |
| RDO                          | 25  | DO                  | Serial interface register read output                                                     |
| AGND                         | 26  | P                   | Analog ground                                                                             |
| AGND                         | 27  | P                   | Analog ground                                                                             |
| VCC                          | 28  | P                   | Analog power supply                                                                       |
| COB_OD                       | 29  | AO                  | OB loop output voltage (odd); connect 0.1- $\mu$ F capacitor between ground               |
| BYPR_OD                      | 30  | AO                  | Input buffer reference bypass (odd)                                                       |
| BYPP_OD                      | 31  | AO                  | CDS positive reference bypass (odd); open or bypass to ground by a 0.1- $\mu$ F capacitor |
| BYPM_OD                      | 32  | AO                  | CDS negative reference bypass (odd); open or bypass to ground by a 0.1- $\mu$ F capacitor |
| BYP_OD                       | 33  | AO                  | CDS common reference bypass (odd); bypass to ground by a 0.1- $\mu$ F capacitor           |
| CCDIN_OD                     | 34  | AI                  | CCD signal input (odd)                                                                    |
| AGND                         | 35  | P                   | Analog ground                                                                             |
| VCC                          | 36  | P                   | Analog supply                                                                             |
| REFN_OD                      | 37  | AO                  | ADC negative reference bypass (odd); bypass to ground by a 0.1- $\mu$ F capacitor         |
| CM_OD                        | 38  | AO                  | ADC common reference (odd); bypass to ground by a 0.1- $\mu$ F capacitor                  |
| REFP_OD                      | 39  | AO                  | ADC positive reference (odd); bypass to ground by a 0.1- $\mu$ F capacitor                |
| VCC                          | 40  | P                   | Analog power supply                                                                       |
| AGND                         | 41  | P                   | Analog ground                                                                             |
| REFP_EV                      | 42  | AO                  | ADC positive reference bypass (even); bypass to ground by a 0.1- $\mu$ F capacitor        |
| CM_EV                        | 43  | AO                  | ADC common reference bypass (even); bypass to ground by a 0.1- $\mu$ F capacitor          |
| REFN_EV                      | 44  | AO                  | ADC negative reference bypass (even); bypass to ground by a 0.1- $\mu$ F capacitor        |
| VCC                          | 45  | P                   | Analog power supply                                                                       |
| AGND                         | 46  | P                   | Analog ground                                                                             |
| CCDIN_EV                     | 47  | AI                  | CCD signal input (even)                                                                   |
| BYP_EV                       | 48  | AO                  | CDS common reference bypass (even); bypass to ground by a 0.1- $\mu$ F capacitor          |
| BYPM_EV                      | 49  | AO                  | CDS negative reference bypass (even); bypass to ground by a 0.1- $\mu$ F capacitor        |
| BYPP_EV                      | 50  | AO                  | CDS positive reference bypass (even); bypass to ground by a 0.1- $\mu$ F capacitor        |
| BYPR_EV                      | 51  | AO                  | Input buffer reference bypass (even); bypass to ground by a 0.1- $\mu$ F capacitor        |
| COB_EV                       | 52  | AO                  | OB loop output voltage (even); connect 0.1- $\mu$ F capacitor between ground              |
| VCC                          | 53  | P                   | Analog power supply                                                                       |
| AGND                         | 54  | P                   | Analog ground                                                                             |
| AGND                         | 55  | P                   | Analog ground                                                                             |
| CDS/SH_SEL                   | 56  | DI                  | CDS/SH mode select; high = CDS mode, low = SH mode                                        |
| CA1                          | 57  | DI                  | Chip address 1                                                                            |
| CA0                          | 58  | DI                  | Chip address 0                                                                            |
| $\overline{\text{INPUTCLP}}$ | 59  | DI                  | Input clamp control (active low)                                                          |
| $\overline{\text{RESET}}$    | 60  | DI                  | Asynchronous register reset (active low)                                                  |
| OUTENB                       | 61  | DI                  | Output enable/disable; high = high impedance, low = output enable                         |
| AGND                         | 62  | P                   | Analog ground                                                                             |
| VCC                          | 63  | P                   | Analog power supply                                                                       |
| DGND                         | 64  | P                   | Digital ground for digital outputs (B0–B11)                                               |

FUNCTIONAL BLOCK DIAGRAM

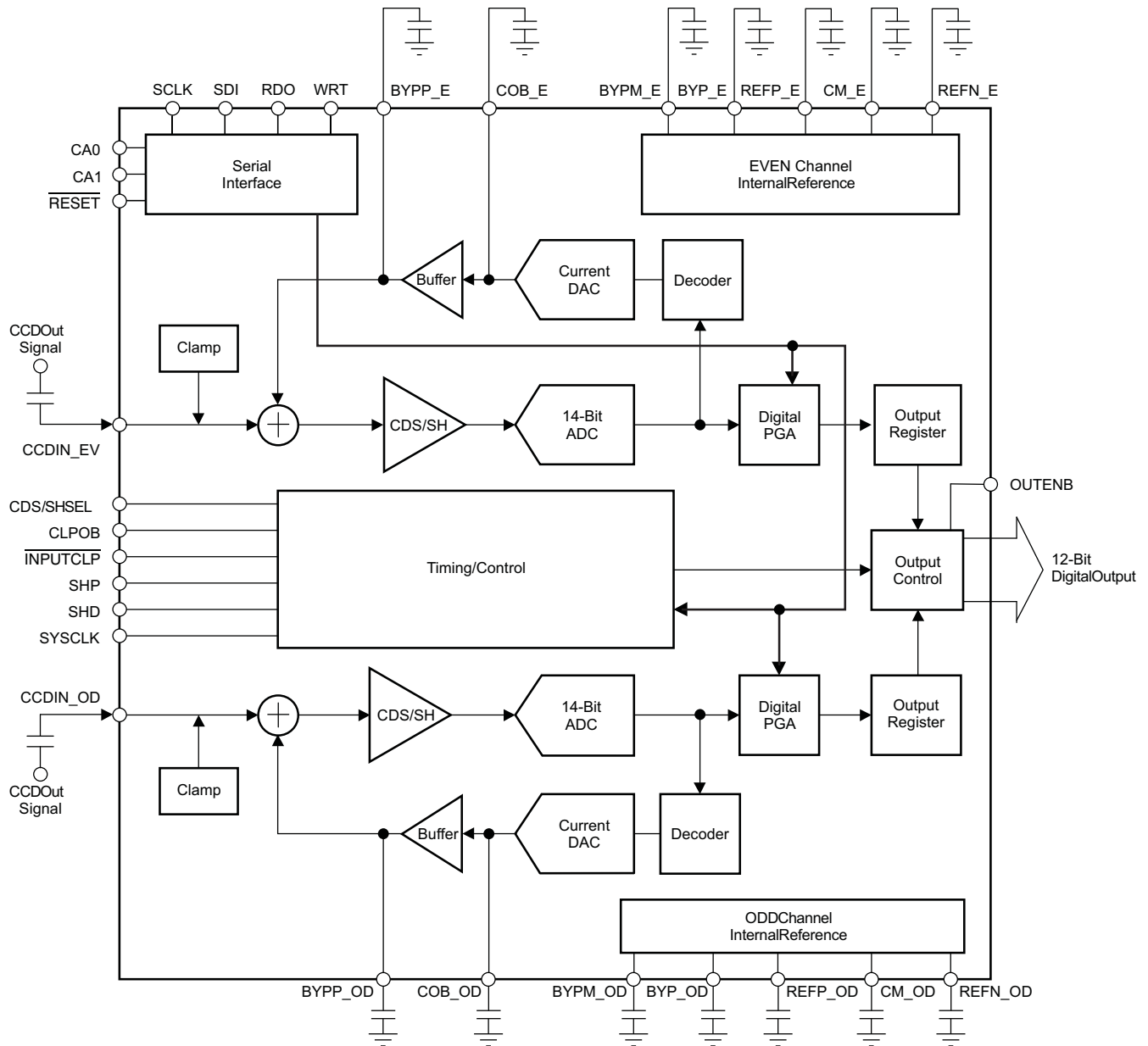

PRODUCTPREVIEW

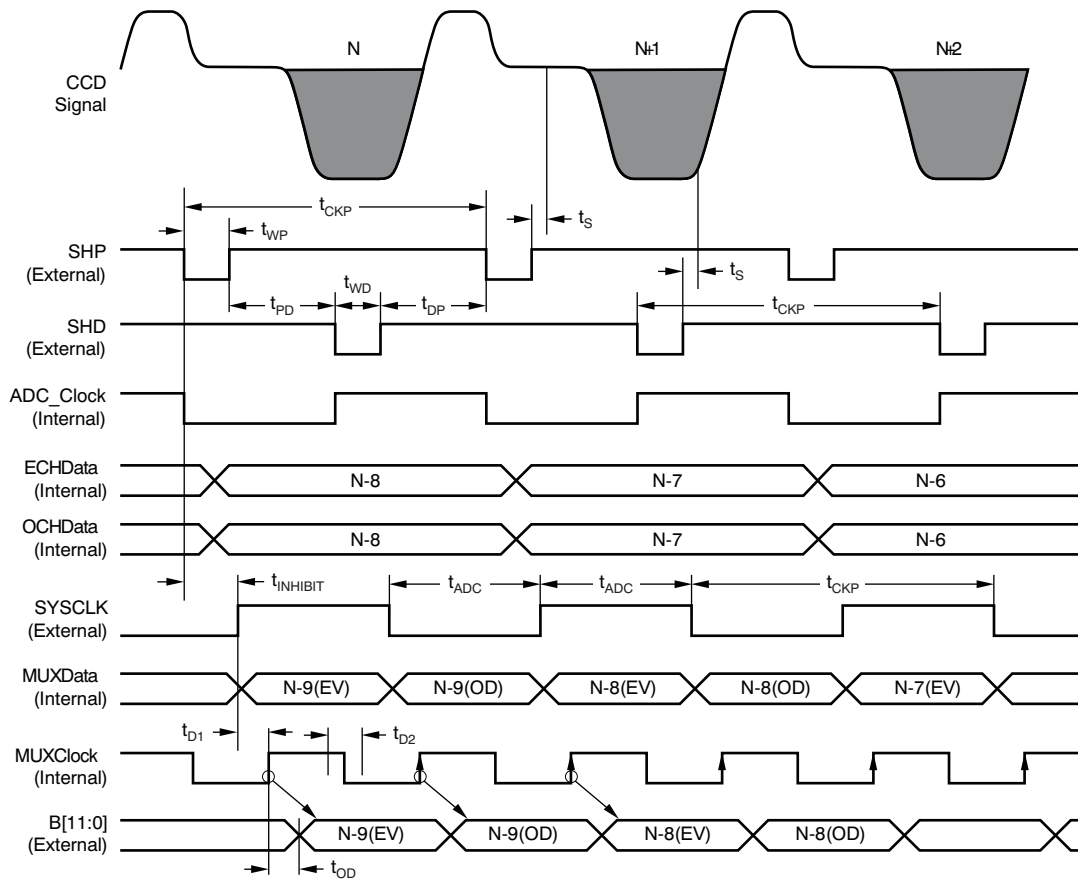

Figure 1. VSP5010 CDS Mode Timing Specifications (Even and Odd Channels) 1

**TIMING CHARACTERISTICS**

| SYMBOL        | PARAMETER                                               | MIN | TYP | MAX | UNIT |
|---------------|---------------------------------------------------------|-----|-----|-----|------|
| $t_{CKP}$     | Clock period <sup>(1)</sup>                             | 32  |     |     | ns   |
| $t_{ADC}$     | SYSCLK pulse width <sup>(2)</sup>                       | 16  |     |     | ns   |
| $t_{WP}$      | SHD pulse width                                         | 6   | 8.3 |     | ns   |
| $t_{WD}$      | SHD pulse width                                         | 6   | 8.3 |     | ns   |
| $t_{PD}$      | SHP trailing edge to SHD leading edge                   | 8   |     |     | ns   |
| $t_{DP}$      | SHD trailing edge to SHP leading edge                   | 8   |     |     | ns   |
| $t_s$         | Sampling delay                                          |     | 3.5 |     | ns   |
| $t_{INHIBIT}$ | Inhibited clock period                                  | 10  |     |     | ns   |
| $t_{D1}$      | Internal MUX clock delay 1 <sup>(3)</sup>               |     | 4   |     | ns   |
| $t_{D2}$      | Internal MUX clock delay 2 <sup>(3)</sup>               |     | 4   |     | ns   |
| $t_{OD}$      | Output delay at data output delay = 0 ns <sup>(4)</sup> |     | 13  |     | ns   |
|               | Output delay at data output delay = 2 ns <sup>(4)</sup> |     |     |     | ns   |
| DL            | Data latency <sup>(5)</sup>                             |     | 13  |     | ns   |

(1) Design ensured. A shipment final test is 33 ns.  
 (2) Design ensured. A shipment final test is 16.7 ns.  
 (3) See the [Serial Interface](#) section.  
 (4) Load = 25 pF, data output delay = 2 ns indicates that the delay time is set by the Configuration Register of the serial interface. See the [MPX Clock Edge Phase](#) configuration.  
 (5) Depending on an *Internal MUX clock delay* and *output delay*, latency can carry out the decrease of an increase.

PRODUCTPREVIEW



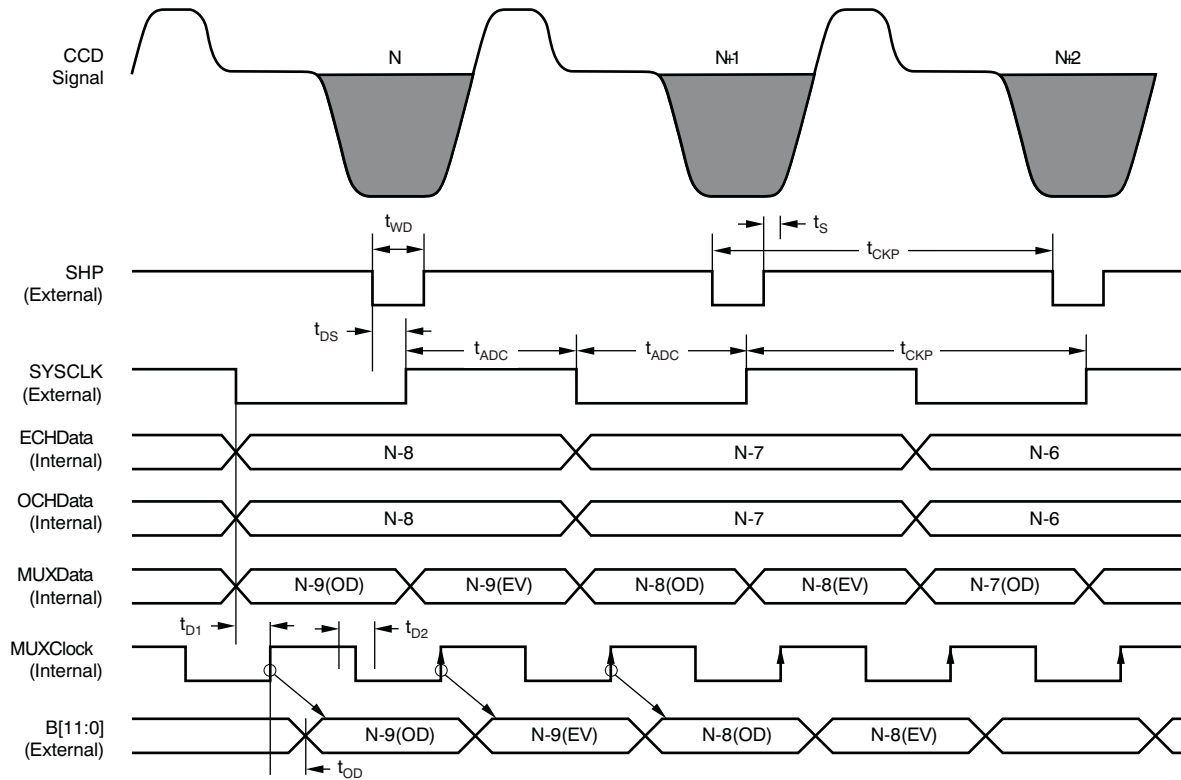

Figure 2. VSP5010 SH Mode Timing Specifications (Even and Odd Channels) 1

**TIMING CHARACTERISTICS**

| SYMBOL    | PARAMETER                                               | MIN | TYP  | MAX | UNIT   |
|-----------|---------------------------------------------------------|-----|------|-----|--------|
| $t_{CKP}$ | Clock period <sup>(1)</sup>                             | 32  |      |     | ns     |
| $t_{ADC}$ | SYSCLK pulse width <sup>(2)</sup>                       | 16  |      |     | ns     |
| $t_{WD}$  | SHD pulse width                                         | 6   | 8.3  |     | ns     |
| $t_S$     | Sampling delay                                          |     | 3.5  |     | ns     |
| $t_{DS}$  | SHD trailing edge to SYSCLK leading edge                | -8  |      | +6  | ns     |
| $t_{D1}$  | Internal MUX clock delay 1 <sup>(3)</sup>               |     | 4.5  |     | ns     |
| $t_{D2}$  | Internal MUX clock delay 2 <sup>(3)</sup>               |     | 12.5 |     | ns     |
| $t_{OD}$  | Output delay at data output delay = 0 ns <sup>(4)</sup> |     | 13   |     | ns     |
|           | Output delay at data output delay = 2 ns <sup>(5)</sup> |     | 17   |     | ns     |
| DL        | Data latency                                            |     | 9    |     | Clocks |

- (1) Design ensured. A shipment final test is 33 ns.
- (2) Design ensured. A shipment final test is 16.7 ns.
- (3) See the [Serial Interface](#) section.
- (4) Load = 25 pF, data output delay = 0 ns indicates that the delay time is set by the Configuration Register of the serial interface.
- (5) Load = 25 pF, data output delay = 2 ns indicates that the delay time is set by the Configuration Register of the serial interface.

PRODUCTPREVIEW

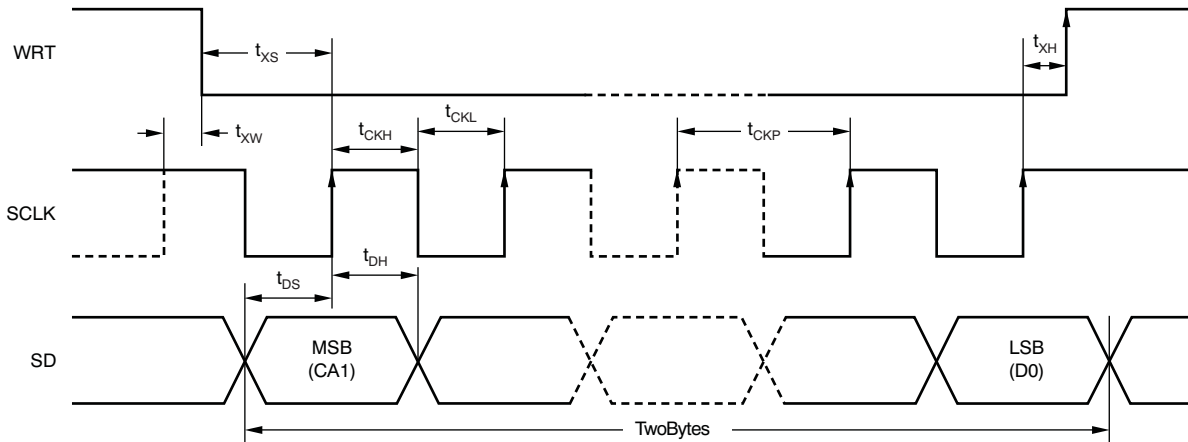
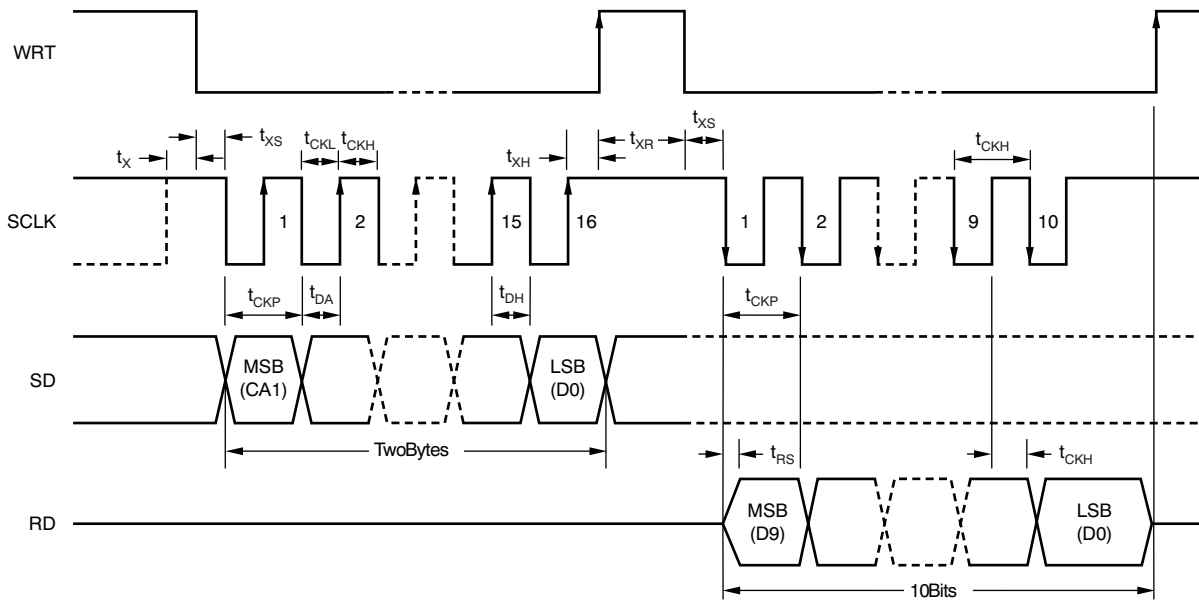

Figure 3. Serial Interface Timing Specification 1

**TIMING CHARACTERISTICS (31-MHz Operation)**

| SYMBOL    | PARAMETER               | MIN | TYP | MAX | UNIT |
|-----------|-------------------------|-----|-----|-----|------|
| $t_{CKP}$ | Clock period            | 100 |     |     | ns   |
| $t_{CKH}$ | Clock high pulse width  | 40  |     |     | ns   |
| $t_{CKL}$ | Clock low pulse width   | 40  |     |     | ns   |
| $t_{DS}$  | Data setup time         | 30  |     |     | ns   |
| $t_{DH}$  | Data hold time          | 30  |     |     | ns   |
| $t_{xS}$  | WRTL to SCLK setup time | 15  |     |     | ns   |
| $t_{xH}$  | SCLK to WRT hold time   | 15  |     |     | ns   |
| $t_{xW}$  | WRT setup time          | 15  |     |     | ns   |

PRODUCTPREVIEW

**Figure 4. Serial Interface Timing Specification 2 (Read)**
**TIMING CHARACTERISTICS**

| SYMBOL    | PARAMETER                 | MIN | TYP | MAX | UNIT |
|-----------|---------------------------|-----|-----|-----|------|
| $t_{CKP}$ | Clock period              | 100 |     |     | ns   |
| $t_{CKH}$ | Clock high pulse width    | 40  |     |     | ns   |
| $t_{CKL}$ | Clock low pulse width     | 40  |     |     | ns   |
| $t_{DS}$  | Data setup time (write)   | 30  |     |     | ns   |
| $t_{DH}$  | Data hold time (write)    | 30  |     |     | ns   |
| $t_{XS}$  | WRTL to SCLK setup time   | 15  |     |     | ns   |
| $t_{XH}$  | SCLK to WRT hold time     | 15  |     |     | ns   |
| $t_{XW}$  | WRT setup time            | 15  |     |     | ns   |
| $t_{WRW}$ | Minimum WRT width         | 10  |     |     | ns   |
| $t_{RS}$  | Data setup time (reading) |     |     | 30  | ns   |

## APPLICATION INFORMATION

### OVERVIEW

The VSP5010 was developed as an analog front-end for charge-coupled device (CCD) line imaging sensor applications such as copiers, facsimiles, and so forth. The VSP5010 provides two independent EVEN/ODD channels for processing, with each channel operating at 31 MHz.

Output signals from each EVEN/ODD channel of the CCD image sensor are sampled at the correlated double sampling (CDS) circuit and then transmitted to a 14-bit, high-precision analog-to-digital converter (ADC). The ADC output is then amplified by the required gain at a digital programmable gain amplifier (DPGA) and then rounded to 12-bit data, and output sequentially as EVEN/ODD data that are synchronized with SYSCLK. The CDS stage can be also used as a sample-and-hold (S/H) step.

Each channel has an optical black level clamp circuit (OB loop) and automatically compensates offsets of the CCD and CDS/SH during the OB pixel period (CLPOB). The OB level output value can be set at a required value through the serial interface. DC bias lost in ac coupling is reproduced as an input clamp voltage, which is the necessary level for internal operation. Input clamp voltage is charged to a capacitor that is connected to CCDIN during a dummy pixel period (INPUTCLP) by SHP.

Gain setting, operation polarity of each clock, operating mode selection, and so forth are done through the serial interface by accessing internal registers. Each setting of register values can be reset to its respective default value by setting RESET to active low.

### CORRELATED DOUBLE SAMPLER (CDS) AND SAMPLE/HOLD (S/H) CIRCUIT

The CDS circuit removes low-frequency and/or common-mode noise, such as fluctuations per pixel, from the CCD image sensor output. Noises longer than one pixel period among the input signals are rejected by a subtraction operation at the CDS circuit. Figure 5 shows a simplified CDS block diagram.

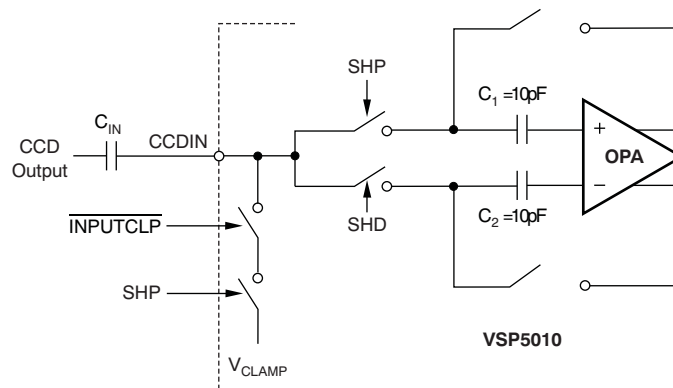

Figure 5. Simplified Block Diagram

The CDS circuit can be configured as a sample-and-hold (S/H) circuit by the CDS/SH SEL pin. A simplified S/H circuit block diagram is shown in Figure 6.

In the S/H mode, the input clamp voltage ( $V_{CLAMP}$ ) is charged by  $\overline{INPUTCLP}$  and the sampling signal (SHD) to the  $C_{IN}$  capacitor.  $\overline{INPUTCLP}$  is activated at the dummy pixel (or OB pixel) of CCD. By these operations, the dummy pixel (or OB pixel) level voltage is fixed to  $V_{CLAMP}$  at the CCDIN terminal.

When sampling for the OB pixel and an effective pixel, the  $V_{CLAMP}$  voltage is charged to capacitor  $C_1$ , and  $C_2$  charges the voltage lower than  $V_{CLAMP}$  according to the signal voltage from the CCD. As the voltage difference in  $C_1$  and  $C_2$  is acquired during the hold period, signals from the CCD are acquired as voltage based on  $V_{CLAMP}$ .

In CDS mode, the signal voltage is received as the voltage difference between the sampled voltage of SHP (reference level) and SHD (data level); the signal level is not affected even when  $V_{CLAMP}$  charges or fluctuates because of leakage, etc. However, when operated as S/H, the  $V_{CLAMP}$  fluctuation is read as an offset error because the signal is acquired based on  $V_{CLAMP}$ . In order to prevent  $V_{CLAMP}$  leakage, a buffer is inserted at the input in S/H mode.

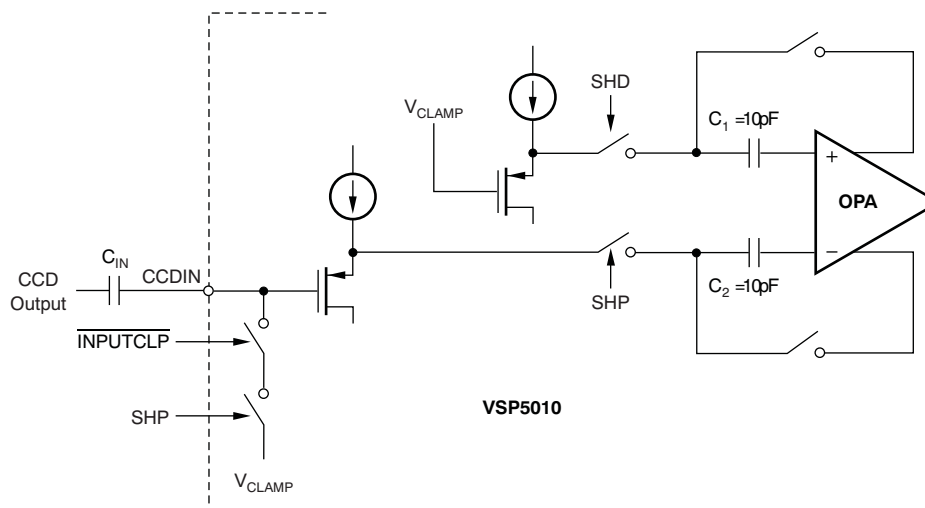

Figure 6. Simplified Sample-and-Hold (S/H) Circuit

### INPUT CLAMP (DUMMY PIXEL CLAMP)

Output from the CCD image sensor is ac-coupled with the VSP5010 through a capacitor. The purpose of the input clamp is to reproduce the dc bias lost by ac coupling, and to supply an optimum dc bias for proper device operation at the CDS/SH circuit. Refer to Figure 5 and Figure 6 for simplified block diagrams of the input clamp circuit.

The input signal level is clamped to the internal reference voltage by activating both SHP (during CDS mode; activate SHD during SH mode) and  $\overline{INPUTCLP}$  during the CCD dummy pixel output period.

### HIGH PRECISION A/D CAPACITOR

The ADC block of the VSP5010 consists of a pipeline architecture. This converter has a complete differential circuit configuration and error correction circuit, and ensures 14-bit resolution.

Circuits that generate the necessary reference voltage at the ADC are built inside the device, and are shown as REFP (high-potential reference), REFN (low-potential reference), and CM (common-mode voltage) pins outside the device. In order to assure ADC accuracy, these reference voltage pins must be sufficiently decoupled by a capacitor (0.1  $\mu$ F recommended).

## DIGITAL PROGRAMMABLE GAIN AMPLIFIER (DPGA)

The DPGA circuit can control gain values in the range of 0 V/V to 16 V/V by inputting a digital code through the serial interface. Gain changes linearly in proportion to the code setting, as shown in Figure 7.

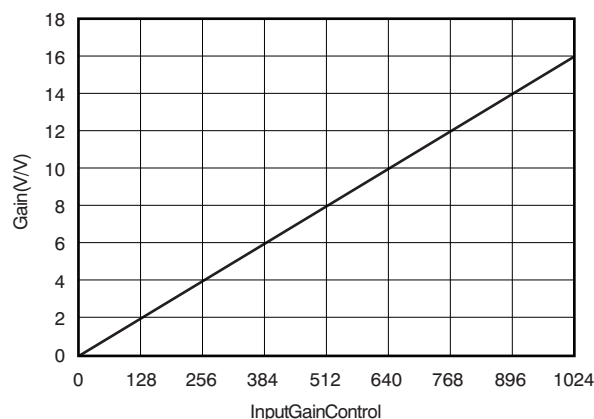

Figure 7. Block Diagram of CDS and Input Clamp

## OPTICAL BLACK LEVEL (OB) LOOP AND OB CLAMP LEVEL

The VSP5010 has a built-in self-calibration circuit (OB loop) that compensates the OB level by using optical black (OB) pixels output from the CCD image sensor. A block diagram of the OB loop and OB clamp circuit is shown in Figure 8.

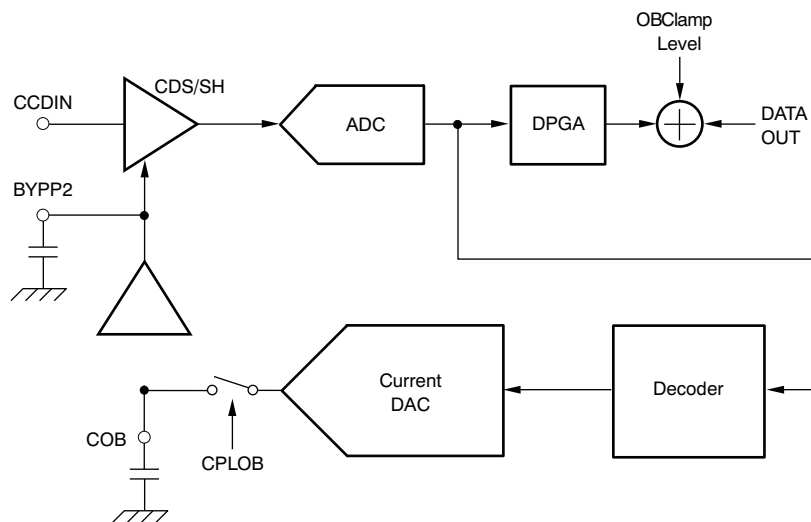

Figure 8. OB Loop and OB Level Clamp

The CCD offset is compensated by converging this calibration circuit while activating CLPOB during a period when OB pixels are output from the CCD.

In CDS mode, CCD offset is compensated as a difference between the reference level and the data level of the OB pixel. In SH mode,  $V_{CLAMP}$  is compensated by INPUTCLP as the difference between fixed dummy pixels and the OB pixels.

These compensated signal levels are recognized as actual *OB levels*, and outputs are clamped to OB levels set by the serial interface. These OB levels are the base of black for the effective pixel period thereafter.

The DPGA is a gain stage outside the OB loop; therefore, OB levels are not affected even when the gain changes.

The converging time of the OB loop is determined based on the capacitor value connected to the COB terminal and the output from the current output digital-to-analog converter (DAC) of the loop. The time constant (T) can be obtained from [Equation 1](#):

$$T = C / (16384 \times I_{\text{MIN}}) \quad (1)$$

Where:

- C is the capacitor value connected to COB,
- $I_{\text{MIN}}$  is the minimum current (0.15  $\mu\text{A}$ ) of the current DAC, which has a current equivalent to 1 LSB of the DAC converter output.

When C = 0.1  $\mu\text{F}$ , T is 40.7  $\mu\text{s}$ .

The slew rate (SR) can be obtained from [Equation 2](#):

$$SR = I_{\text{MAX}} / C \quad (2)$$

Where:

- C is the capacitor value connected to COB,
- $I_{\text{MAX}}$  is the maximum current (153  $\mu\text{A}$ ) of the current DAC, which is the equivalent current to 1023 LSB of the DAC converter output.

The OB clamp level (digital output value) can be set externally through the serial interface by inputting a digital code to the OB clamp level register. The digital code to be input and the corresponding OB clamp level are shown in [Table 2](#).

**Table 2. Input Code and OB Clamp Level to be Set**

| CODE                | CLAMP LEVEL (LSB) |
|---------------------|-------------------|
|                     | VSP5010 (12-BIT)  |
| 0000 0000b          | 0                 |
| 0000 0001b          | 2                 |
| —                   | —                 |
| 0100 1111b          | 158               |
| 0101 0000 (default) | 160               |
| 0101 0001b          | 162               |
| —                   | —                 |
| 1011 1111b          | 508               |
| 1111 1111b          | 510               |

## SETTLING OF OB LOOP AND INPUT CLAMP

Because these capacitors are discharged at start-up and after a long standby state, these two capacitors must be charged to the proper operational voltage.

The charging time for the input clamp voltage is the logical AND of SHP (SHD in S/H mode) and  $\overline{\text{INPUTCLP}}$ . The actual charging time per line is the duration of the SHP pulse times the number of dummy pixels in the line. Equally, COB is only charged during the OB pixel period. Therefore, some time is necessary to bring the VSP5010 into a normal operating state at device start-up.

Though start-up time depends on the number of dummy and pixels per line, at least 500 ms to 1 s should be allowed.

## STANDBY MODE

Normal operation mode and standby mode can be switched by the serial interface.

In standby mode, power consumption can be saved; all operation is suspended other than the interface circuit and reference voltage supply. During standby mode, additional power consumption may be obtained by suspending SYCLK. When restoring a SYCLK that was suspended during standby mode, more than two clocks of SYCLK must be acquired before inputting commands.

## OUTPUT DATA DELAY

Large transient noise occurs when the output data change because several logic lines change simultaneously. When this transient noise timing overlaps the analog signal sampling timing, it may affect the ADC converting value. To avoid this effect, changing the timing of the VSP5010 output data can be delayed in approximately 3-ns steps by serial control.

The delay value set refers to the increase in default time between SYSCLKL and the data output set in the timing specification.

## TEST MODE AND TEST PATTERN

The VSP5010 can be set to test mode by setting the configuration register. During test mode, the test pattern generated inside will be output with or without a CCD input signal.

There are two test patterns. One is a pattern which outputs the code that is the OB level +128 LSB for a specified number of pixels (stripe pattern); the other is a pattern which increments the output code from 1 to 4095 by a specified number of LSBs per pixel (gradation pattern). These patterns can be selected by setting the configuration register through the serial interface.

## CHIP ADDRESS

The VSP5010 has two chip address pins, CA0 and CA1. Setting these pins gives a particular address for the device, and the data-writing device can be selected by the address in serial interface data. By this function, the serial interface can be used as a common line for up to four devices.

## REGISTER READING

Each register data can be read from the RDO pin by setting bit A3 of the serial interface data to '1', and setting the reading register address to A[2:0].

After writing the address to specify which register is to be read, assert WRT and apply SCLK. The value of the register is output sequentially on the RD pin. Refer to the [Serial Interface Timing Specification 2 \(Read\)](#) for details.

While reading registers, the writing function is disabled.



## SERIAL INTERFACE REGISTER DESCRIPTION

The serial interface of the VSP5010 is composed of three signals; SDI, SCLK, and WRT. SDI data are sequentially stored to the shift register at the rising edge of SCLK, and shift register data are stored to the parallel latch at the rising edge of WRT.

Serial data are two bytes of fixed length and are composed of a two-bit chip address, a four-bit register address, and 10-bit data. The chip address can only write register to a device that matches its value to the address set by CA0 and CA1. By using this two-bit chip address, the serial interface can be shared by other devices.

Both the address (A[3:0]) and the serial data (D[9:0]) start with the MSB (A3, D9) and end with the LSB (A0, D0). When data with more than two bytes are applied, the final two bytes immediately before the rising edge of WRT are effective, and any data written before that are lost.

Register configuration and serial data format are shown in [Table 3](#).

Each register value is defined at the time of device power-on (VCC = 2.1 V (typ)).

**Table 3. Serial Interface Command Data Format**

| REGISTERS                | MSB              |     |    |    |    |    |    |    |    |    |    |    |    |    |     | LSB |    |
|--------------------------|------------------|-----|----|----|----|----|----|----|----|----|----|----|----|----|-----|-----|----|
|                          | CA1              | CA0 | A3 | A2 | A1 | A0 | D9 | D8 | D7 | D6 | D5 | D4 | D3 | D2 | D1  |     | D0 |
| Configuration            | X <sup>(1)</sup> | X   | 0  | 0  | 0  | 0  | 0  | 0  | 0  | C7 | C6 | 0  | C4 | 0  | C2  | C1  | C0 |
| Standby mode and Clk Dly | X                | X   | 0  | 0  | 0  | 1  | D9 | D8 | D7 | D6 | D5 | D4 | D3 | D2 | 0   | S0  |    |
| DPGA gain EVEN           | X                | X   | 0  | 0  | 1  | 0  | G9 | G8 | G7 | G6 | G5 | G4 | G3 | G2 | G1  | G0  |    |
| DPGA gain ODD            | X                | X   | 0  | 0  | 1  | 1  | G9 | G8 | G7 | G6 | G5 | G4 | G3 | G2 | G1  | G0  |    |
| OB clamp level EVEN      | X                | X   | 0  | 1  | 0  | 0  | 0  | 0  | O7 | O6 | O5 | O4 | O3 | O2 | O1  | O0  |    |
| OB clamp level ODD       | X                | X   | 0  | 1  | 0  | 1  | 0  | 0  | O7 | O6 | O5 | O4 | O3 | O2 | O1  | O0  |    |
| Test mode                | X                | X   | 0  | 1  | 1  | 0  | 0  | 0  | 0  | 0  | T5 | T4 | 0  | T2 | 0   | T0  |    |
| Internal ADCK monitor    | X                | X   | 0  | 1  | 1  | 1  | 0  | 0  | 0  | 0  | 0  | 0  | 0  | 0  | PT1 | 0   |    |
| Read out                 | X                | X   | 1  | R2 | R1 | R0 | X  | X  | X  | X  | X  | X  | X  | X  | X   | X   | X  |

### Configuration Register Description (Address = 000h)

| Bits C[2:0] | Clock Polarity                              |                                             |                                             |
|-------------|---------------------------------------------|---------------------------------------------|---------------------------------------------|
|             | <b>Bit C0 (INPUTCLP Polarity)</b>           | <b>Bit C1 (CLPOB Polarity)</b>              | <b>Bit C2 (SHP/SHD Polarity)</b>            |
|             | 0 = Active low (default)<br>1 = Active high | 0 = Active low (default)<br>1 = Active high | 0 = Active low (default)<br>1 = Active high |
| Bit C4      | Data Output Order                           |                                             |                                             |
|             | 0 = EVEN/ODD (default)<br>1 = ODD/EVEN      |                                             |                                             |
| Bits C[7:6] | Data Output Delay                           |                                             |                                             |
|             | Bit C7                                      | Bit C6                                      |                                             |
|             | 0 = Time (0 ns, typ) (default)              | 0 Delay = time (0 ns, typ) (default)        |                                             |
|             | 0 = Delay time (2 ns, typ)                  | 1 = Delay time (2 ns, typ)                  |                                             |
|             | 1 = Delay time (4 ns, typ)                  | 0 = Delay time (4 ns, typ)                  |                                             |
|             | 1 = Delay time (6 ns, typ)                  | 1 = Delay time (6 ns, typ)                  |                                             |

(1) X = Don't care.

**Standby Mode and MPX Clock Edge Phase Description (Address = 01h)**

|                    |                                                                     |
|--------------------|---------------------------------------------------------------------|
| <b>Bit S0</b>      | <b>Standby/Normal Operation Select</b>                              |
|                    | 0 = Normal operation mode (default)<br>1 = Standby mode             |
| <b>Bits D[8:1]</b> | <b>MPX Clock Edge Phase</b>                                         |
|                    | Figure 9 illustrates the MPX clock edge phase.                      |
| <b>Bits D[5:2]</b> | <b>Dlyedge 2 Timing (except constant delay <math>t_{D1}</math>)</b> |
|                    | 0000b = Delay time (1.6 ns)                                         |
|                    | 1000b = Delay time (8.0 ns) (default, 0.8 ns/step)                  |
|                    | 1111b = Delay time (13.6 ns)                                        |
| <b>Bits D[9:6]</b> | <b>Dlyedge 1 Timing (except constant delay <math>t_{D1}</math>)</b> |
|                    | 0000b = Delay time (–2.4 ns)                                        |
|                    | 1000b = Delay time (0 ns) (default, 0.3 ns/step)                    |
|                    | 1111b = Delay time (2.1 ns)                                         |

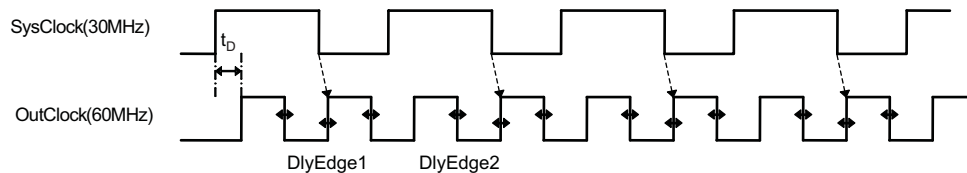
**Figure 9. MPX Clock Edge Phase**
**CAUTION:**

Please do not use at Delayedge 1 > Delayedge 2

(example: D[5:2] = 0000b and D[9:6] = 1111b)

Delayedge2 should maintain sufficient width to allow proper data output timing.

**Internal ADCK Monitor Description (Address = 07h)**

|               |                                                                                       |
|---------------|---------------------------------------------------------------------------------------|
| <b>Bit D1</b> | <b>PT1</b>                                                                            |
|               | 0 = Normal<br>1 = Internal ADC clock to B0 (ADC output, bit 0, least significant bit) |

**EVEN Channel Gain Register Description (Address = 02h)**

|                    |                                         |
|--------------------|-----------------------------------------|
| <b>Bits G[9:0]</b> | <b>Gain Value</b>                       |
|                    | GAIN[9:0] /64 (default = 00 0100 0000b) |

**ODD Channel Gain Register Description (Address = 03h)**

|                    |                                         |
|--------------------|-----------------------------------------|
| <b>Bits G[9:0]</b> | <b>Gain Value</b>                       |
|                    | GAIN[9:0] /64 (default = 00 0100 0000b) |

**EVEN Channel OB Clamp Register Description (Address = 04h)**

|                    |                                       |
|--------------------|---------------------------------------|
| <b>Bits O[7:0]</b> | <b>OB Clamp Level</b>                 |
|                    | 2 LSB × O[7:0] (default = 0101 0000b) |

**ODD Channel OB Clamp Register Description (Address = 05h)**

|                    |                                       |
|--------------------|---------------------------------------|
| <b>Bits O[7:0]</b> | <b>OB Clamp Level</b>                 |
|                    | 2 LSB × O[7:0] (default = 0101 0000b) |

**Test Mode Register Description (Address = 06h)**

|                    |                                                                       |                                                                       |
|--------------------|-----------------------------------------------------------------------|-----------------------------------------------------------------------|
| <b>Bit T0</b>      | <b>Test Mode Enable/Disable</b>                                       |                                                                       |
|                    | 0 = Disable (default)<br>1 = Enable                                   |                                                                       |
| <b>Bit T2</b>      | <b>Test Pattern Select</b>                                            |                                                                       |
|                    | 0 = Gradation pattern (default)<br>1 = Stripe pattern                 |                                                                       |
| <b>Bits T[5:4]</b> | <b>Test Pattern Data Interval</b>                                     |                                                                       |
|                    | <b>Bit T5</b>                                                         | <b>Bit T4</b>                                                         |
|                    | 0 = Stripe pattern (8 pixels), gradation pattern (2 pixels) (default) | 0 = Stripe pattern (8 pixels), gradation pattern (2 pixels) (default) |
|                    | 0 = Stripe pattern (16 pixels), gradation pattern (4 pixels)          | 1 = Stripe pattern (16 pixels), gradation pattern (4 pixels)          |
|                    | 1 = Stripe pattern (32 pixels), gradation pattern (8 pixels)          | 0 = Stripe pattern (32 pixels), gradation pattern (8 pixels)          |
|                    | 1 = Stripe pattern (64 pixels), gradation pattern (16 pixels)         | 1 = Stripe pattern (64 pixels), gradation pattern (16 pixels)         |

**Register Read Out Description**

|                   |                                    |
|-------------------|------------------------------------|
| <b>Bit A[2:0]</b> | <b>R[2:0]</b>                      |
|                   | 2:0 = Set reading register address |

**POWER SUPPLY, GROUNDING AND DEVICE DECOUPLING RECOMMENDATIONS**

The VSP5010 incorporates a very high-precision and high-speed ADC and analog circuitry which are vulnerable to any extraneous noise from the rails or elsewhere. For this reason, although the VSP5010 has analog and digital supply pins, it should be treated as an analog component; all supply pins except for VDD should be powered by the analog supply only. This configuration ensures the most consistent results, because digital power lines often carry high levels of wideband noise that would otherwise be coupled into the device and degrade the achievable performance.

Proper grounding, short lead length, and the use of ground planes are also very important for high-frequency designs. Multilayer printed circuit boards (PCBs) are recommended for the best performance; these types of boards offer distinct advantages such as minimizing ground impedance, separation of signal layers by ground layers, and so forth. It is highly recommended that analog and digital ground pins of the VSP5010 be joined together at the IC and be connected only to the analog ground of the system.

The driver stage of the digital outputs (B[11:0]) is supplied through a dedicated supply VDD (pin 18) and it should be separated from the other supply pins completely or at least with a ferrite bead.

Because of the high operation speed, the converter also generates high-frequency current transients and noise that are fed back into the supply and reference lines. This additional interference requires the supply and reference pins be sufficiently bypassed. In most cases, 0.1- $\mu$ F ceramic chip capacitors are adequate to decouple the reference pins. Supply pins should be decoupled to the ground plane with a parallel combination of tantalum (1- $\mu$ F to 22- $\mu$ F) and ceramic (0.1- $\mu$ F) capacitors. The effectiveness of the decoupling depends largely on the proximity to the individual pin. VDD should be decoupled to the proximity of DGND (pin 17 and pin 64).

**PACKAGING INFORMATION**

| Orderable Device | Status <sup>(1)</sup> | Package Type | Package Drawing | Pins | Package Qty | Eco Plan <sup>(2)</sup> | Lead/<br>Ball Finish | MSL Peak Temp <sup>(3)</sup> | Samples<br>(Requires Login) |
|------------------|-----------------------|--------------|-----------------|------|-------------|-------------------------|----------------------|------------------------------|-----------------------------|
| VSP5010PM        | ACTIVE                | LQFP         | PM              | 64   | 160         | Green (RoHS & no Sb/Br) | A42 SNBI             | Level-1-260C-UNLIM           |                             |
| VSP5010PMG6      | ACTIVE                | LQFP         | PM              | 64   | 160         | Green (RoHS & no Sb/Br) | A42 SNBI             | Level-1-260C-UNLIM           |                             |
| VSP5010PMR       | ACTIVE                | LQFP         | PM              | 64   | 1000        | Green (RoHS & no Sb/Br) | A42 SNBI             | Level-1-260C-UNLIM           |                             |
| VSP5010PMRG6     | ACTIVE                | LQFP         | PM              | 64   | 1000        | Green (RoHS & no Sb/Br) | A42 SNBI             | Level-1-260C-UNLIM           |                             |

<sup>(1)</sup> The marketing status values are defined as follows:

**ACTIVE:** Product device recommended for new designs.

**LIFEBUY:** TI has announced that the device will be discontinued, and a lifetime-buy period is in effect.

**NRND:** Not recommended for new designs. Device is in production to support existing customers, but TI does not recommend using this part in a new design.

**PREVIEW:** Device has been announced but is not in production. Samples may or may not be available.

**OBSOLETE:** TI has discontinued the production of the device.

<sup>(2)</sup> Eco Plan - The planned eco-friendly classification: Pb-Free (RoHS), Pb-Free (RoHS Exempt), or Green (RoHS & no Sb/Br) - please check <http://www.ti.com/productcontent> for the latest availability information and additional product content details.

**TBD:** The Pb-Free/Green conversion plan has not been defined.

**Pb-Free (RoHS):** TI's terms "Lead-Free" or "Pb-Free" mean semiconductor products that are compatible with the current RoHS requirements for all 6 substances, including the requirement that lead not exceed 0.1% by weight in homogeneous materials. Where designed to be soldered at high temperatures, TI Pb-Free products are suitable for use in specified lead-free processes.

**Pb-Free (RoHS Exempt):** This component has a RoHS exemption for either 1) lead-based flip-chip solder bumps used between the die and package, or 2) lead-based die adhesive used between the die and leadframe. The component is otherwise considered Pb-Free (RoHS compatible) as defined above.

**Green (RoHS & no Sb/Br):** TI defines "Green" to mean Pb-Free (RoHS compatible), and free of Bromine (Br) and Antimony (Sb) based flame retardants (Br or Sb do not exceed 0.1% by weight in homogeneous material)

<sup>(3)</sup> MSL, Peak Temp. -- The Moisture Sensitivity Level rating according to the JEDEC industry standard classifications, and peak solder temperature.

**Important Information and Disclaimer:** The information provided on this page represents TI's knowledge and belief as of the date that it is provided. TI bases its knowledge and belief on information provided by third parties, and makes no representation or warranty as to the accuracy of such information. Efforts are underway to better integrate information from third parties. TI has taken and continues to take reasonable steps to provide representative and accurate information but may not have conducted destructive testing or chemical analysis on incoming materials and chemicals. TI and TI suppliers consider certain information to be proprietary, and thus CAS numbers and other limited information may not be available for release.

In no event shall TI's liability arising out of such information exceed the total purchase price of the TI part(s) at issue in this document sold by TI to Customer on an annual basis.

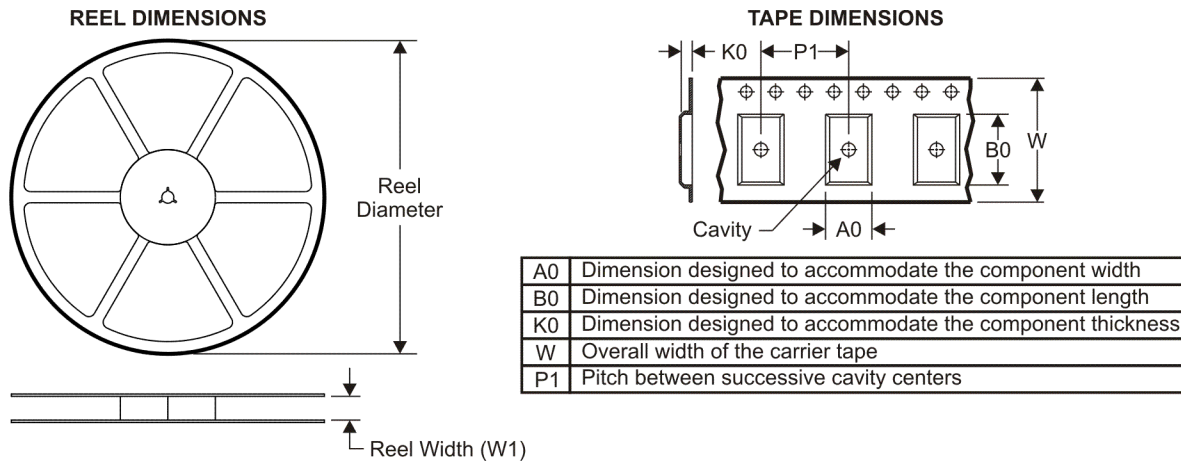
**TAPE AND REEL INFORMATION**

**QUADRANT ASSIGNMENTS FOR PIN 1 ORIENTATION IN TAPE**

\*All dimensions are nominal

| Device     | Package Type | Package Drawing | Pins | SPQ  | Reel Diameter (mm) | Reel Width W1 (mm) | A0 (mm) | B0 (mm) | K0 (mm) | P1 (mm) | W (mm) | Pin1 Quadrant |
|------------|--------------|-----------------|------|------|--------------------|--------------------|---------|---------|---------|---------|--------|---------------|
| VSP5010PMR | LQFP         | PM              | 64   | 1000 | 330.0              | 25.4               | 12.8    | 12.8    | 1.9     | 16.0    | 24.0   | Q2            |

**TAPE AND REEL BOX DIMENSIONS**



\*All dimensions are nominal

| Device     | Package Type | Package Drawing | Pins | SPQ  | Length (mm) | Width (mm) | Height (mm) |
|------------|--------------|-----------------|------|------|-------------|------------|-------------|
| VSP5010PMR | LQFP         | PM              | 64   | 1000 | 346.0       | 346.0      | 41.0        |

PM (S-PQFP-G64)

PLASTIC QUAD FLATPACK

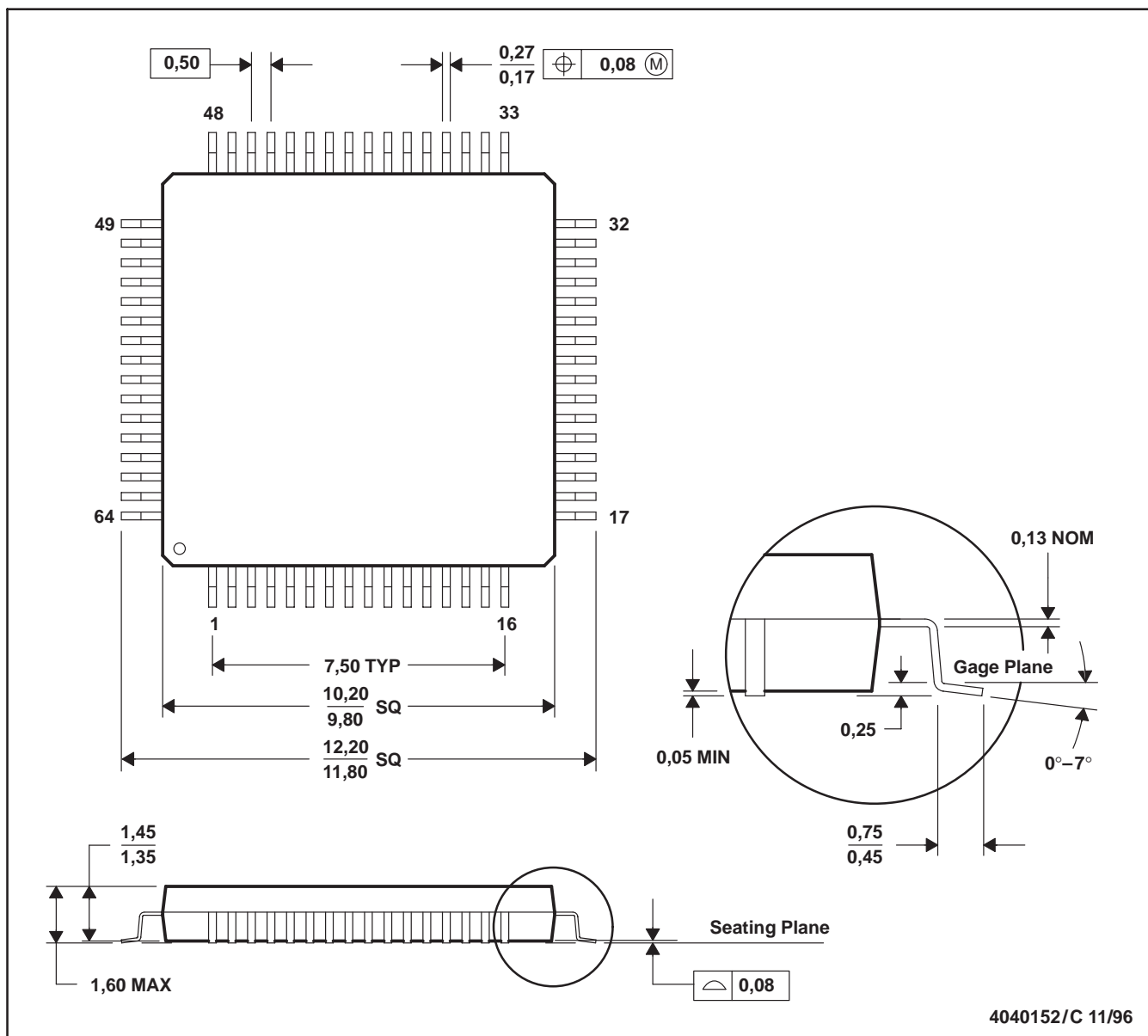

- NOTES: A. All linear dimensions are in millimeters.  
 B. This drawing is subject to change without notice.  
 C. Falls within JEDEC MS-026  
 D. May also be thermally enhanced plastic with leads connected to the die pads.

PM (S-PQFP-G64)

PLASTIC QUAD FLATPACK

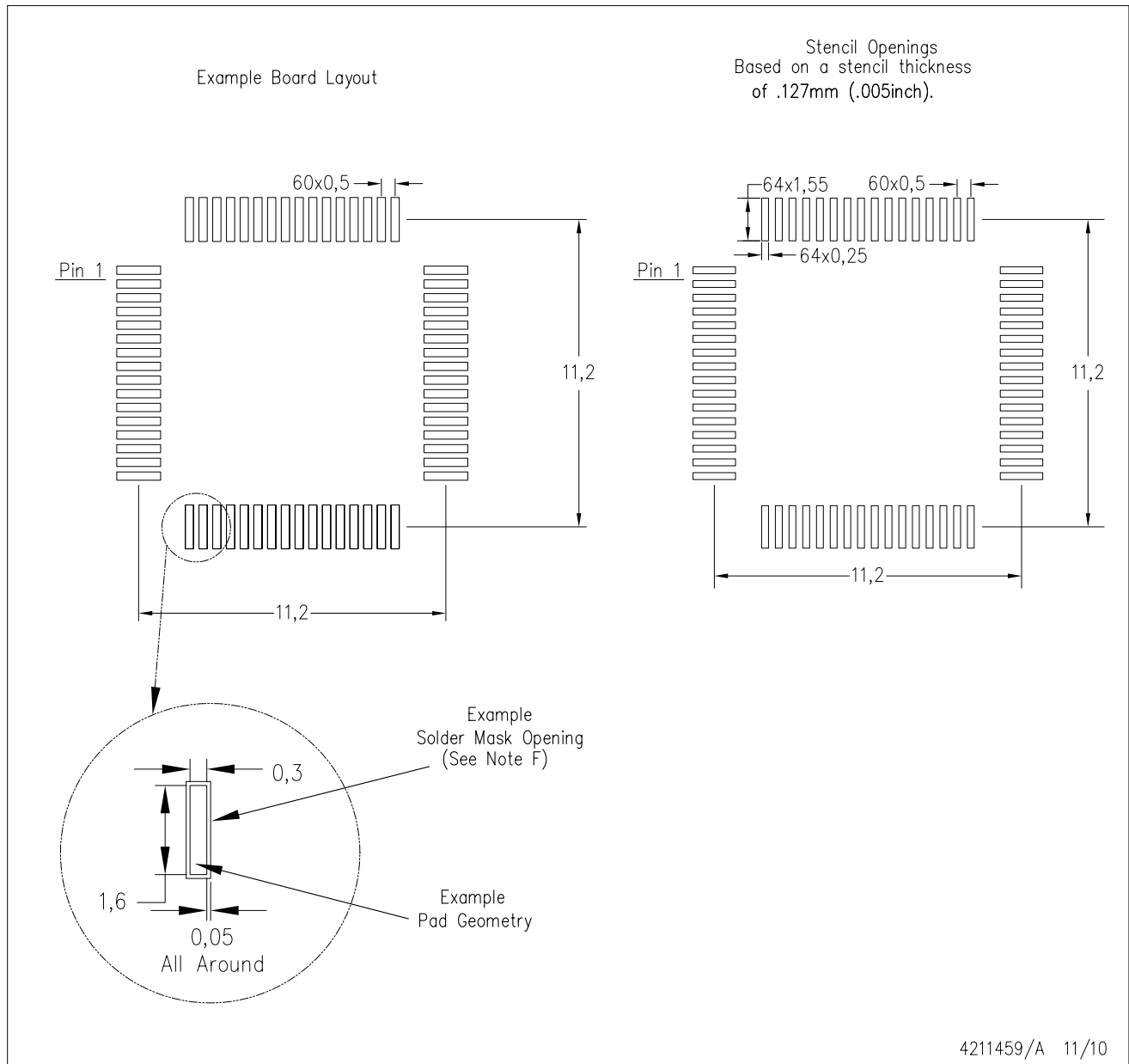

- NOTES:
- A. All linear dimensions are in millimeters.
  - B. This drawing is subject to change without notice.
  - C. Laser cutting apertures with trapezoidal walls and also rounding corners will offer better paste release. Customers should contact their board assembly site for stencil design recommendations. Example stencil design based on a 50% volumetric metal load solder paste. Refer to IPC-7525 for other stencil recommendations.
  - D. Customers should contact their board fabrication site for solder mask tolerances between and around signal pads.



## IMPORTANT NOTICE

Texas Instruments Incorporated and its subsidiaries (TI) reserve the right to make corrections, modifications, enhancements, improvements, and other changes to its products and services at any time and to discontinue any product or service without notice. Customers should obtain the latest relevant information before placing orders and should verify that such information is current and complete. All products are sold subject to TI's terms and conditions of sale supplied at the time of order acknowledgment.

TI warrants performance of its hardware products to the specifications applicable at the time of sale in accordance with TI's standard warranty. Testing and other quality control techniques are used to the extent TI deems necessary to support this warranty. Except where mandated by government requirements, testing of all parameters of each product is not necessarily performed.

TI assumes no liability for applications assistance or customer product design. Customers are responsible for their products and applications using TI components. To minimize the risks associated with customer products and applications, customers should provide adequate design and operating safeguards.

TI does not warrant or represent that any license, either express or implied, is granted under any TI patent right, copyright, mask work right, or other TI intellectual property right relating to any combination, machine, or process in which TI products or services are used. Information published by TI regarding third-party products or services does not constitute a license from TI to use such products or services or a warranty or endorsement thereof. Use of such information may require a license from a third party under the patents or other intellectual property of the third party, or a license from TI under the patents or other intellectual property of TI.

Reproduction of TI information in TI data books or data sheets is permissible only if reproduction is without alteration and is accompanied by all associated warranties, conditions, limitations, and notices. Reproduction of this information with alteration is an unfair and deceptive business practice. TI is not responsible or liable for such altered documentation. Information of third parties may be subject to additional restrictions.

Resale of TI products or services with statements different from or beyond the parameters stated by TI for that product or service voids all express and any implied warranties for the associated TI product or service and is an unfair and deceptive business practice. TI is not responsible or liable for any such statements.

TI products are not authorized for use in safety-critical applications (such as life support) where a failure of the TI product would reasonably be expected to cause severe personal injury or death, unless officers of the parties have executed an agreement specifically governing such use. Buyers represent that they have all necessary expertise in the safety and regulatory ramifications of their applications, and acknowledge and agree that they are solely responsible for all legal, regulatory and safety-related requirements concerning their products and any use of TI products in such safety-critical applications, notwithstanding any applications-related information or support that may be provided by TI. Further, Buyers must fully indemnify TI and its representatives against any damages arising out of the use of TI products in such safety-critical applications.

TI products are neither designed nor intended for use in military/aerospace applications or environments unless the TI products are specifically designated by TI as military-grade or "enhanced plastic." Only products designated by TI as military-grade meet military specifications. Buyers acknowledge and agree that any such use of TI products which TI has not designated as military-grade is solely at the Buyer's risk, and that they are solely responsible for compliance with all legal and regulatory requirements in connection with such use.

TI products are neither designed nor intended for use in automotive applications or environments unless the specific TI products are designated by TI as compliant with ISO/TS 16949 requirements. Buyers acknowledge and agree that, if they use any non-designated products in automotive applications, TI will not be responsible for any failure to meet such requirements.

Following are URLs where you can obtain information on other Texas Instruments products and application solutions:

### Products

|                             |                                                                    |
|-----------------------------|--------------------------------------------------------------------|
| Audio                       | <a href="http://www.ti.com/audio">www.ti.com/audio</a>             |
| Amplifiers                  | <a href="http://amplifier.ti.com">amplifier.ti.com</a>             |
| Data Converters             | <a href="http://dataconverter.ti.com">dataconverter.ti.com</a>     |
| DLP® Products               | <a href="http://www.dlp.com">www.dlp.com</a>                       |
| DSP                         | <a href="http://dsp.ti.com">dsp.ti.com</a>                         |
| Clocks and Timers           | <a href="http://www.ti.com/clocks">www.ti.com/clocks</a>           |
| Interface                   | <a href="http://interface.ti.com">interface.ti.com</a>             |
| Logic                       | <a href="http://logic.ti.com">logic.ti.com</a>                     |
| Power Mgmt                  | <a href="http://power.ti.com">power.ti.com</a>                     |
| Microcontrollers            | <a href="http://microcontroller.ti.com">microcontroller.ti.com</a> |
| RFID                        | <a href="http://www.ti-rfid.com">www.ti-rfid.com</a>               |
| RF/IF and ZigBee® Solutions | <a href="http://www.ti.com/lprf">www.ti.com/lprf</a>               |

### Applications

|                               |                                                                                          |
|-------------------------------|------------------------------------------------------------------------------------------|
| Communications and Telecom    | <a href="http://www.ti.com/communications">www.ti.com/communications</a>                 |
| Computers and Peripherals     | <a href="http://www.ti.com/computers">www.ti.com/computers</a>                           |
| Consumer Electronics          | <a href="http://www.ti.com/consumer-apps">www.ti.com/consumer-apps</a>                   |
| Energy and Lighting           | <a href="http://www.ti.com/energy">www.ti.com/energy</a>                                 |
| Industrial                    | <a href="http://www.ti.com/industrial">www.ti.com/industrial</a>                         |
| Medical                       | <a href="http://www.ti.com/medical">www.ti.com/medical</a>                               |
| Security                      | <a href="http://www.ti.com/security">www.ti.com/security</a>                             |
| Space, Avionics and Defense   | <a href="http://www.ti.com/space-avionics-defense">www.ti.com/space-avionics-defense</a> |
| Transportation and Automotive | <a href="http://www.ti.com/automotive">www.ti.com/automotive</a>                         |
| Video and Imaging             | <a href="http://www.ti.com/video">www.ti.com/video</a>                                   |
| Wireless                      | <a href="http://www.ti.com/wireless-apps">www.ti.com/wireless-apps</a>                   |

TI E2E Community Home Page

[e2e.ti.com](http://e2e.ti.com)

Mailing Address: Texas Instruments, Post Office Box 655303, Dallas, Texas 75265  
Copyright © 2011, Texas Instruments Incorporated