

Aluminum Capacitors Radial Semi-Professional

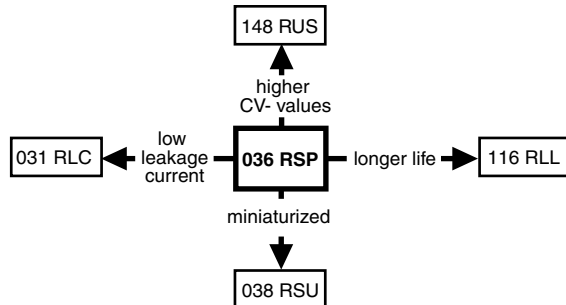

Fig.1 Component outline



FEATURES

- Polarized aluminum electrolytic capacitors, non-solid electrolyte
- Radial leads, cylindrical aluminum case, all-insulated (light blue)
- Natural pitch 2.5 mm and 5 mm
- Charge and discharge proof
- Miniaturized, high CV-product per unit volume
- Reduced leakage current
- Lead (Pb)-free versions are RoHS compliant

**RoHS
COMPLIANT**

APPLICATIONS

- Automotive, telecommunication, industrial, EDP and audio-video
- Coupling, decoupling, smoothing, filtering, buffering, timing
- Portable and mobile equipment (small size, low mass)

MARKING

The capacitors are marked (where possible) with the following information:

- Rated capacitance (in μF)
- Tolerance on rated capacitance, code letter in accordance with IEC 60062 (M for $\pm 20\%$)
- Rated voltage (in V)
- Date code in accordance with IEC 60062
- Code indicating factory of origin
- Name of manufacturer
- Minus-sign on top to identify the negative terminal
- Series number (036)

QUICK REFERENCE DATA	
DESCRIPTION	VALUE
Nominal case sizes (\varnothing D x L in mm)	5 x 11 and 8.2 x 11
Rated capacitance range, C_R	0.47 to 470 μF
Tolerance on C_R	$\pm 20\%$; $\pm 10\%$ on request
Rated voltage range, U_R	6.3 to 160 V
Category temperature range	- 55 to + 85 °C
Endurance test at 85 °C	2000 hours
Useful life at 105 °C	750 hours
Useful life at 85 °C	3000 hours
Useful life at 40 °C, 1.4 x I_R applied	80 000 hours
Shelf life at 0 V, 85 °C	500 hours
Based on sectional specification	IEC 60384-4/EN130 300
Climatic category IEC 60068	55/085/56

SELECTION CHART FOR C_R , U_R AND RELEVANT NOMINAL CASE SIZES (\varnothing D x L in mm)										
C_R (μF)	U_R (V)									
	6.3	10	16	25	35	40	50	63	100	160
0.47	-	-	-	-	-	-	-	5 x 11	-	-
1.0	-	-	-	-	-	-	-	5 x 11	-	-
2.2	-	-	-	-	-	-	-	5 x 11	-	8.2 x 11
3.3	-	-	-	-	-	-	-	5 x 11	-	-
4.7	-	-	-	-	-	-	-	5 x 11	-	8.2 x 11
6.8	-	-	-	-	-	-	-	5 x 11	-	-
10	-	-	-	-	-	-	5 x 11	5 x 11	8.2 x 11	-
15	-	-	-	-	-	5 x 11	-	8.2 x 11	-	-
22	-	-	-	-	5 x 11	-	-	5 x 11	8.2 x 11	-
33	-	-	5 x 11	-	-	-	5 x 11	8.2 x 11	-	-
47	-	5 x 11	-	-	5 x 11	-	8.2 x 11	8.2 x 11	-	-
68	-	-	-	5 x 11	-	8.2 x 11	-	8.2 x 11	-	-
100	5 x 11	-	5 x 11	8.2 x 11	-	-	8.2 x 11	-	-	-
150	-	5 x 11	8.2 x 11	-	8.2 x 11	-	-	-	-	-
220	-	8.2 x 11	8.2 x 11	8.2 x 11	-	-	-	-	-	-
330	8.2 x 11	-	8.2 x 11	-	-	-	-	-	-	-
470	-	8.2 x 11	-	-	-	-	-	-	-	-

DIMENSIONS in millimeters **AND AVAILABLE FORMS**

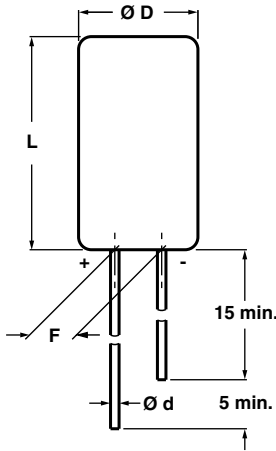
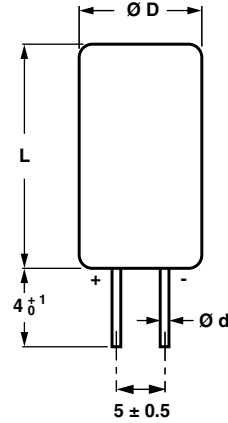
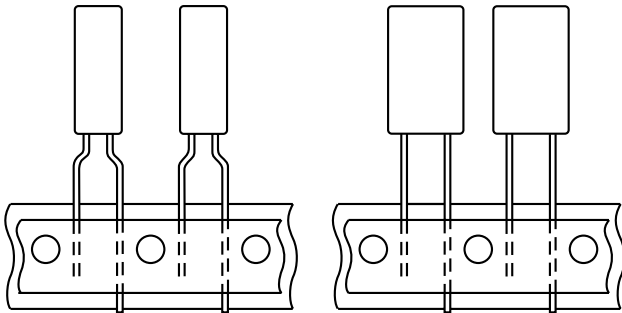

Fig.2 Form CA: Long leads



Case Ø D x L = 8.2 x 11 mm only

Fig.3 Form CB: Cut leads



Pitch F = 5 mm
Case Ø D x L = 5 x 11 and 8.2 x 11 mm

Fig.4 Form TFA: Taped in box (AMMOPACK)

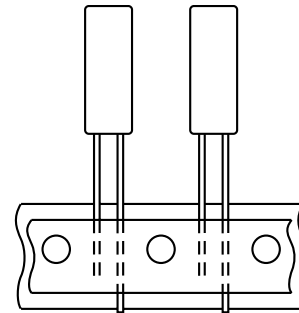

Pitch F = 2.5 mm
Case Ø D x L = 5 x 11 mm only

Fig.5 Form TNA: Taped in box (AMMOPACK)

Table 1

DIMENSIONS in millimeters, MASS AND PACKAGING QUANTITIES								
NOMINAL CASE SIZE Ø D x L	CASE CODE	Ø d	Ø D _{max.}	L _{max.}	F	MASS (g)	PACKAGING QUANTITIES	
							FORM CA, CB	FORM TFA, TNA
5 x 11	11	0.5	5.5	12	2.5 ± 0.5	≈ 0.4	1000	2000
8.2 x 11	13	0.6	8.7	12	5.0 ± 0.5	≈ 1.1	1000	1000

Note

1. Tape dimensions see section 'PACKAGING'



Aluminum Capacitors
Radial Semi-Professional

Vishay BCcomponents

ELECTRICAL DATA	
SYMBOL	DESCRIPTION
C_R	Rated capacitance at 100 Hz, tolerance $\pm 20\%$
I_R	Rated RMS ripple current at 100 Hz, 85 °C
I_{L1}	Max. leakage current after 1 minute at U_R
$\tan \delta$	Max. dissipation factor at 100 Hz
Z	Max. impedance at 10 kHz and 20 °C

Note

Unless otherwise specified, all electrical values in Table 2 apply at $T_{amb} = 20\text{ °C}$, $P = 86\text{ to }106\text{ kPa}$, $RH = 45\text{ to }75\%$

Table 2

ELECTRICAL DATA AND ORDERING INFORMATION														
U_R (V)	C_R 100 Hz (μF)	NOMINAL CASE SIZE $\varnothing D \times L$ (mm)	I_R 100 Hz 85 °C (mA)	I_{L1} 1 min (μA)	$\tan \delta$ 100 Hz	Z 10 kHz (Ω)	ORDERING CODE MAL2036.....							
							BULK PACKAGING				TAPED AMMOPACK			
							LONG LEADS		CUT LEADS		FORM TFA		FORM TNA	
							FORM CA	F (mm)	FORM CB	F (mm)	FORM TFA	F (mm)	FORM TNA	F (mm)
6.3	100	5 x 11	130	7	0.20	1.7	53101E3	2.5	-	-	33101E3	5.0	73101E3	2.5
	330	8.2 x 11	300	16	0.20	0.52	53331E3	5.0	63331E3	5.0	33331E3	5.0	-	-
10	47	5 x 11	95	6	0.16	2.8	54479E3	2.5	-	-	34479E3	5.0	74479E3	2.5
	150	5 x 11	150	12	0.20	1.3	54151E3	2.5	-	-	34151E3	5.0	74151E3	2.5
	220	8.2 x 11	260	17	0.16	0.59	54221E3	5.0	64221E3	5.0	34221E3	5.0	-	-
	470	8.2 x 11	400	31	0.20	0.43	54471E3	5.0	64471E3	5.0	34471E3	5.0	-	-
16	33	5 x 11	90	7	0.14	2.7	55339E3	2.5	-	-	35339E3	5.0	75339E3	2.5
	100	5 x 11	160	13	0.16	1.6	55101E3	2.5	-	-	35101E3	5.0	75101E3	2.5
	150	8.2 x 11	230	18	0.14	0.6	55151E3	5.0	65151E3	5.0	35151E3	5.0	-	-
	220	8.2 x 11	280	24	0.16	0.55	55221E3	5.0	65221E3	5.0	35221E3	5.0	-	-
25	330	8.2 x 11	390	35	0.16	0.48	55331E3	5.0	65331E3	5.0	35331E3	5.0	-	-
	68	5 x 11	140	13	0.14	1.8	56689E3	2.5	-	-	36689E3	5.0	76689E3	2.5
35	100	8.2 x 11	210	18	0.12	0.7	56101E3	5.0	66101E3	5.0	36101E3	5.0	-	-
	220	8.2 x 11	310	36	0.14	0.55	56221E3	5.0	66221E3	5.0	36221E3	5.0	-	-
40	22	5 x 11	87	8	0.10	2.7	90001E3	2.5	-	-	90027E3	5.0	90389E3	2.5
	47	5 x 11	130	13	0.12	1.9	90094E3	2.5	-	-	90098E3	5.0	90391E3	2.5
	150	8.2 x 11	270	35	0.12	0.6	90099E3	5.0	90101E3	5.0	90103E3	5.0	-	-
50	15	5 x 11	72	7	0.10	3.7	57159E3	2.5	-	-	37159E3	5.0	77159E3	2.5
	68	8.2 x 11	180	20	0.10	0.81	57689E3	5.0	67689E3	5.0	37689E3	5.0	-	-
63	10	5 x 11	60	6	0.08	4.5	90004E3	2.5	-	-	90028E3	5.0	90392E3	2.5
	33	5 x 11	110	13	0.10	2.1	90104E3	2.5	-	-	90108E3	5.0	90393E3	2.5
	47	8.2 x 11	160	18	0.08	0.96	90011E3	5.0	90012E3	5.0	90031E3	5.0	-	-
	100	8.2 x 11	250	33	0.10	0.7	90109E3	5.0	90111E3	5.0	90113E3	5.0	-	-
100	0.47	5 x 11	5	4	0.06	85	58477E3	2.5	-	-	38477E3	5.0	78477E3	2.5
	1.0	5 x 11	11	4	0.06	40	58108E3	2.5	-	-	38108E3	5.0	78108E3	2.5
	2.2	5 x 11	25	4	0.06	18	58228E3	2.5	-	-	38228E3	5.0	78228E3	2.5
	3.3	5 x 11	38	5	0.06	12	58338E3	2.5	-	-	38338E3	5.0	78338E3	2.5
	4.7	5 x 11	45	5	0.06	8.5	58478E3	2.5	-	-	38478E3	5.0	78478E3	2.5
	6.8	5 x 11	55	6	0.06	5.9	58688E3	2.5	-	-	38688E3	5.0	78688E3	2.5
	10	5 x 11	70	7	0.06	4.0	58109E3	2.5	-	-	38109E3	5.0	78109E3	2.5
	10	8.2 x 11	120	7	0.04	2.8	90036E3	5.0	90041E3	5.0	90181E3	5.0	-	-
	15	5 x 11	80	9	0.07	3.1	58159E3	2.5	-	-	38159E3	5.0	78159E3	2.5
	22	5 x 11	100	11	0.08	2.7	58229E3	2.5	-	-	38229E3	5.0	78229E3	2.5
	22	8.2 x 11	150	11	0.05	1.4	90117E3	5.0	90118E3	5.0	90139E3	5.0	-	-
	33	8.2 x 11	160	16	0.06	1.2	58339E3	5.0	68339E3	5.0	38339E3	5.0	-	-
	47	8.2 x 11	190	21	0.07	1.0	58479E3	5.0	68479E3	5.0	38479E3	5.0	-	-
	68	8.2 x 11	210	29	0.08	0.88	58689E3	5.0	68689E3	5.0	38689E3	5.0	-	-
160	10	8.2 x 11	80	9	0.06	3.5	59109E3	5.0	69109E3	5.0	39109E3	5.0	-	-
	22	8.2 x 11	110	16	0.06	1.8	59229E3	5.0	69229E3	5.0	39229E3	5.0	-	-
160	2.2	8.2 x 11	45	75	0.05	14	90333E3	5.0	90334E3	5.0	90336E3	5.0	-	-
	4.7	8.2 x 11	62	115	0.07	9.6	90337E3	5.0	90338E3	5.0	90341E3	5.0	-	-

ORDERING EXAMPLE

Electrolytic capacitor 036 series
100 $\mu\text{F}/16\text{ V}$; $\pm 20\%$
Nominal case size: $\varnothing 5 \times 11\text{ mm}$; Form TFA
Ordering code: MAL203635101E3
Former 12NC: 2222 036 35101



ADDITIONAL ELECTRICAL DATA		
PARAMETER	CONDITIONS	VALUE
Voltage		
Surge voltage		$U_s \leq 1.15 U_R$
Reverse voltage		$U_{rev} \leq 1 V$
Current		
Leakage current	After 1 minute $U_R = 6.3$ to $100 V$ $U_R = 160 V$	$I_{L1} \leq 0.006 C_R \times U_R + 3 \mu A$ $I_{L1} \leq 0.1 C_R \times U_R + 40 \mu A$
	After 5 minutes $U_R = 6.3$ to $100 V$ $U_R = 160 V$	$I_{L5} \leq 0.001 C_R \times U_R + 3 \mu A$ $I_{L5} \leq 0.015 C_R \times U_R + 10 \mu A$
Inductance		
Equivalent series inductance (ESL)	Case $\varnothing D \times L = 5 \times 11 mm$	Typ. 13 nH
	Case $\varnothing D \times L = 8.2 \times 11 mm$	Typ. 16 nH
Resistance		
Equivalent series resistance (ESR)	Calculated from $\tan \delta_{max}$ and C_R (see Table 2)	$ESR = \tan \delta / 2 \pi f C_R$

CAPACITANCE (C)

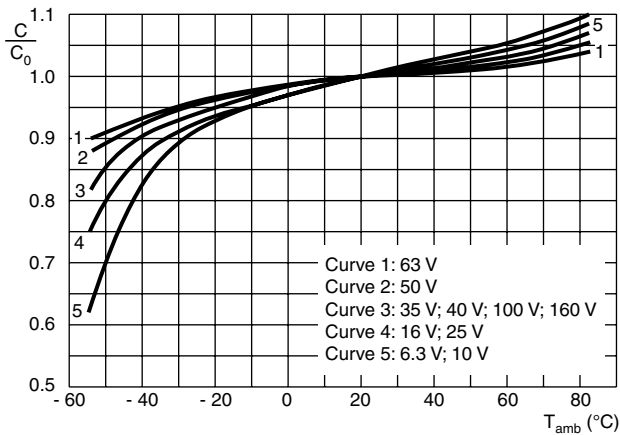

C_0 = Capacitance at 20 °C, 100 Hz

Fig.6 Typical multiplier of capacitance as a function of ambient temperature

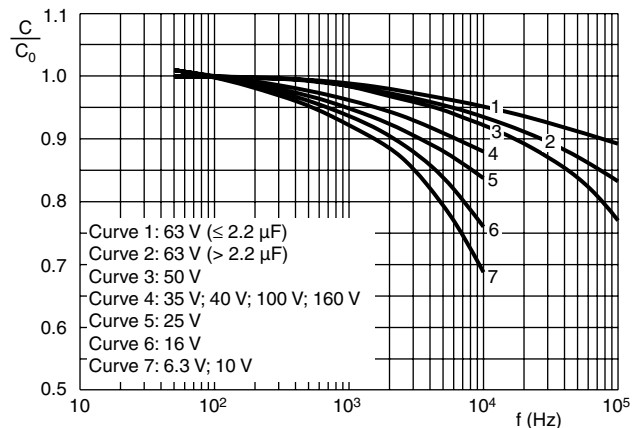

C_0 = Capacitance at 20 °C, 100 Hz

$T_{amb} = 20 \text{ }^\circ\text{C}$

Fig.7 Typical multiplier of capacitance as a function of ambient temperature

IMPEDANCE (Z)

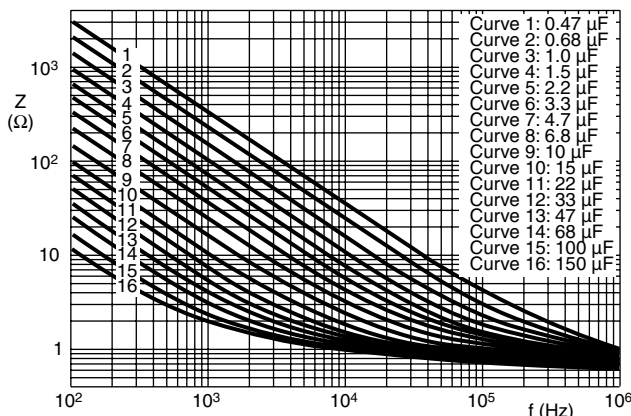

Case $\varnothing D \times L = 5 \times 11 mm$

$T_{amb} = 20 \text{ }^\circ\text{C}$

Fig.8 Typical impedance as a function of frequency

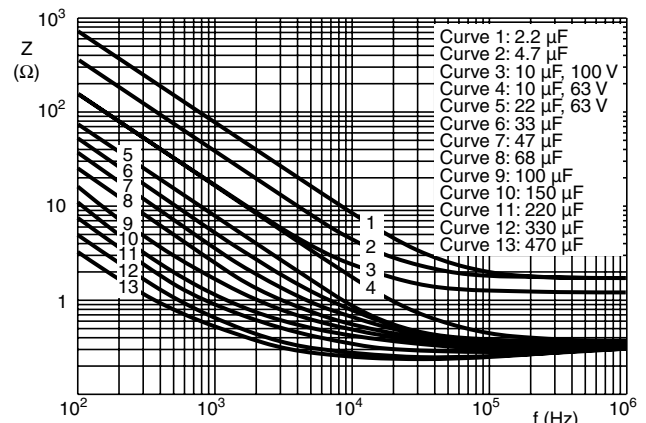

Case $\varnothing D \times L = 8.2 \times 11 mm$

$T_{amb} = 20 \text{ }^\circ\text{C}$

Fig.9 Typical impedance as a function of frequency

RIPPLE CURRENT AND USEFUL LIFE

I_A = Actual ripple current at 100 Hz
 I_R = Rated ripple current at 100 Hz, 85 °C
 (1) Useful life at 85 °C and I_R applied: 3000 hours

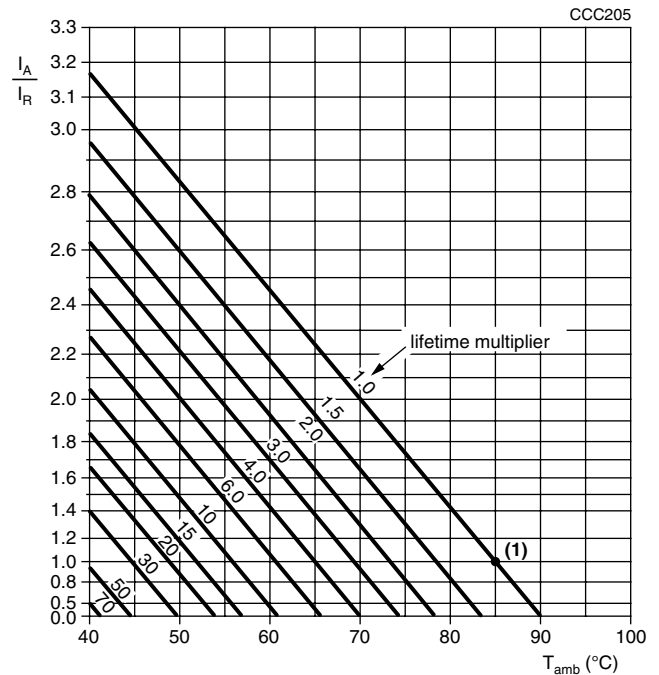

Fig.10 Multiplier of useful life as a function of ambient temperature and ripple current load

Table 3

MULTIPLIER OF RIPPLE CURRENT (I_R) AS A FUNCTION OF FREQUENCY			
FREQUENCY (Hz)	I_R MULTIPLIER		
	$U_R = 6.3$ to 10 V	$U_R = 16$ to 35 V	$U_R = 40$ to 160 V
50	0.90	0.85	0.80
100	1.00	1.00	1.00
300	1.12	1.20	1.25
1000	1.20	1.30	1.40
3000	1.25	1.35	1.50
$\geq 10\ 000$	1.30	1.40	1.60

Table 4

TEST PROCEDURES AND REQUIREMENTS			
TEST		PROCEDURE (quick reference)	REQUIREMENTS
NAME OF TEST	REFERENCE		
Endurance	IEC 60384-4/ EN130300 subclause 4.13	$T_{amb} = 85$ °C; U_R applied; 2000 h	$U_R \leq 6.3$ V; $\Delta C/C$: + 15/- 30 % $U_R > 6.3$ V; $\Delta C/C$: ± 15 % $\tan \delta \leq 1.3$ x spec. limit $Z \leq 2$ x spec. limit $I_{L5} \leq$ spec. limit
Useful life	CECC 30301 subclause 1.8.1	$T_{amb} = 85$ °C; U_R and I_R applied; 3000 h	$U_R \leq 6.3$ V; $\Delta C/C$: + 45/- 50 % $U_R > 6.3$ V; $\Delta C/C$: ± 45 % $\tan \delta \leq 3$ x spec. limit $Z \leq 3$ x spec. limit $I_{L5} \leq$ spec. limit No short or open circuit Total failure percentage: ≤ 1 %
Shelf life (storage at high temperature)	IEC 60384-4/ EN130300 subclause 4.17	$T_{amb} = 85$ °C; no voltage applied; 500 h After test: U_R to be applied for 30 min, 24 to 48 h before measurement	$\Delta C/C$, $\tan \delta$, Z: For requirements See 'Endurance test' above $I_{L5} \leq$ spec. limit



Disclaimer

All product specifications and data are subject to change without notice.

Vishay Intertechnology, Inc., its affiliates, agents, and employees, and all persons acting on its or their behalf (collectively, "Vishay"), disclaim any and all liability for any errors, inaccuracies or incompleteness contained herein or in any other disclosure relating to any product.

Vishay disclaims any and all liability arising out of the use or application of any product described herein or of any information provided herein to the maximum extent permitted by law. The product specifications do not expand or otherwise modify Vishay's terms and conditions of purchase, including but not limited to the warranty expressed therein, which apply to these products.

No license, express or implied, by estoppel or otherwise, to any intellectual property rights is granted by this document or by any conduct of Vishay.

The products shown herein are not designed for use in medical, life-saving, or life-sustaining applications unless otherwise expressly indicated. Customers using or selling Vishay products not expressly indicated for use in such applications do so entirely at their own risk and agree to fully indemnify Vishay for any damages arising or resulting from such use or sale. Please contact authorized Vishay personnel to obtain written terms and conditions regarding products designed for such applications.

Product names and markings noted herein may be trademarks of their respective owners.