

## Glass Passivated Single-Phase Bridge Rectifier

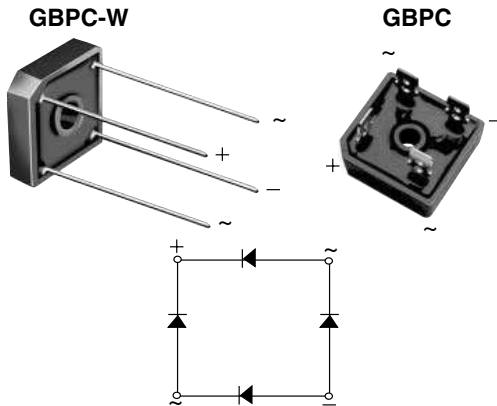

### FEATURES

- UL Recognition file number E54214
- Universal 3-way terminals: snap-on, wire wrap-around, or P.C.B. mounting
- Typical  $I_R$  less than  $0.3 \mu A$
- High surge current capability
- Low thermal resistance
- Solder Dip  $260^\circ C$ , 40 seconds
- Component in accordance to RoHS 2002/95/EC and WEEE 2002/96/EC



### TYPICAL APPLICATIONS

General purpose use in ac-to-dc bridge full wave rectification for Power Supply, Home Appliances, Office Equipment, Industrial Automation applications.

MAJOR RATINGS AND CHARACTERISTICS	
$I_{F(AV)}$	12 A, 15 A, 25 A, 35 A
$V_{RRM}$	50 V to 1000 V
$I_{FSM}$	200 A, 300 A, 300 A, 400 A
$I_R$	$5 \mu A$
$V_F$	1.1 V
$T_j$ max.	$150^\circ C$

### MECHANICAL DATA

**Case:** GBPC, GBPC-W

Epoxy meets UL 94V-0 flammability rating

**Terminals:** Nickel plated on faston lugs or Silver plated on wire leads, solderable per J-STD-002B and JESD22-B102D. E4 suffix for commercial grade. Suffix letter "W" added to indicate wire leads (e.g. GBPC12005W).

**Polarity:** As marked, positive lead by beveled corner

**Mounting Torque:** 20 inches-lbs. max.

MAXIMUM RATINGS ( $T_A = 25^\circ C$ unless otherwise noted)									
PARAMETER	SYMBOL	GBPC12, 15, 25, 35							UNIT
		005	01	02	04	06	08	10	
Maximum repetitive peak reverse voltage	$V_{RRM}$	50	100	200	400	600	800	1000	V
Maximum RMS voltage	$V_{RMS}$	35	70	140	280	420	560	700	V
Maximum DC blocking voltage	$V_{DC}$	50	100	200	400	600	800	1000	V
Maximum average forward rectified output current (see Fig. 1)	$I_{F(AV)}$	GBPC12: 12 GBPC15: 15 GBPC25: 25 GBPC35: 35							A
Peak forward surge current single sine-wave superimposed on rated load	$I_{FSM}$	GBPC12: 200 GBPC15: 300 GBPC25: 300 GBPC35: 400							A
Rating (non-repetitive, for t greater than 1 ms and less than 8.3 ms) for fusing	$I^2t$	GBPC12: 160 GBPC15: 375 GBPC25: 375 GBPC35: 660							$A^2 \text{ sec}$
RMS isolation voltage from case to leads	$V_{ISO}$	2500							V
Operating junction storage temperature range	$T_J, T_{STG}$	- 55 to + 150							$^\circ C$



ELECTRICAL CHARACTERISTICS (T <sub>A</sub> = 25 °C unless otherwise noted)											
PARAMETER	TEST CONDITIONS	SYMBOL	GBPC12, 15, 25, 35							UNIT	
			005	01	02	04	06	08	10		
Maximum instantaneous forward drop per diode	GBPC12 GBPC15 GBPC25 GBPC35	I <sub>F</sub> = 6.0 A I <sub>F</sub> = 7.5 A I <sub>F</sub> = 12.5 A I <sub>F</sub> = 17.5 A	V <sub>F</sub>	1.1							V
Maximum reverse DC current at rated DC blocking voltage per diode	T <sub>A</sub> = 25 °C T <sub>A</sub> = 125 °C	I <sub>R</sub>	5.0 500							μA	
Typical junction capacitance per diode	at 4 V, 1 MHz	C <sub>J</sub>	300							pF	

THERMAL CHARACTERISTICS (T <sub>A</sub> = 25 °C unless otherwise noted)										
PARAMETER	SYMBOL	GBPC12, 15, 25, 35							UNIT	
		005	01	02	04	06	08	10		
Typical thermal resistance <sup>(1)</sup>	GBPC12-25 GBPC35	R <sub>θJC</sub>	1.9 1.4							°C/W

**Note:**

- (1) Thermal resistance from junction to case per diode
- (2) Bolt down on heatsink with silicone thermal compound between bridge and mounting surface for maximum heat transfer with #10 screw

ORDERING INFORMATION				
PREFERRED P/N	UNIT WEIGHT (g)	PREFERRED PACKAGE CODE	BASE QUANTITY	DELIVERY MODE
GBPC1206-E4/51	15.79	51	100	Paper Box
GBPC1506-E4/51	15.79	51	100	Paper Box
GBPC2506-E4/51	15.79	51	100	Paper Box
GBPC3506-E4/51	15.79	51	100	Paper Box
GBPC1206W-E4/51	13.8	51	100	Paper Box
GBPC1506W-E4/51	13.8	51	100	Paper Box
GBPC2506W-E4/51	13.8	51	100	Paper Box
GBPC3506W-E4/51	13.8	51	100	Paper Box

## RATINGS AND CHARACTERISTICS CURVES

( $T_A = 25^\circ\text{C}$  unless otherwise noted)

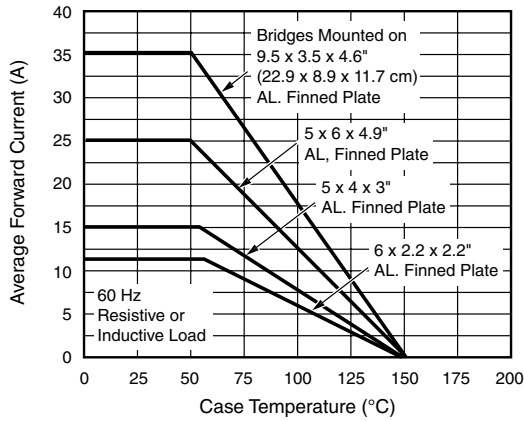

Figure 1. Maximum Output Rectified Current

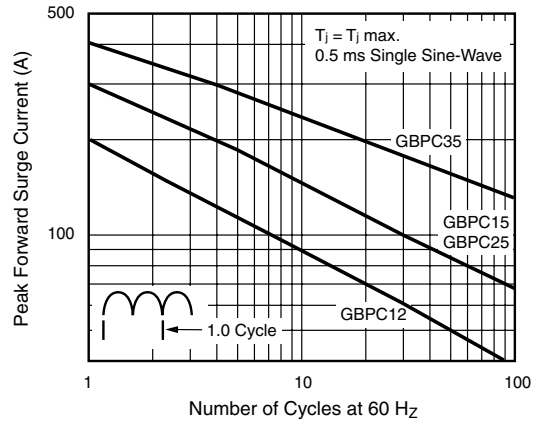

Figure 4. Maximum Non-Repetitive Peak Forward Surge Current Per Diode

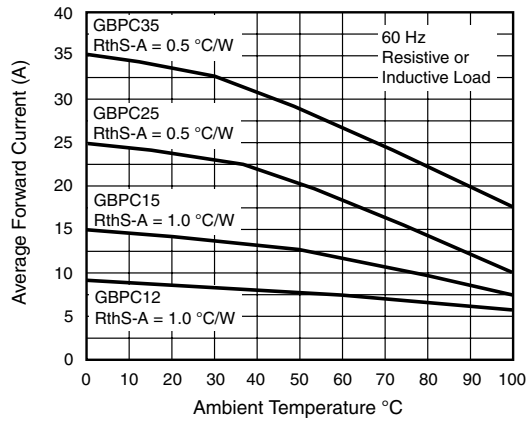

Figure 2. Maximum Output Rectified Current

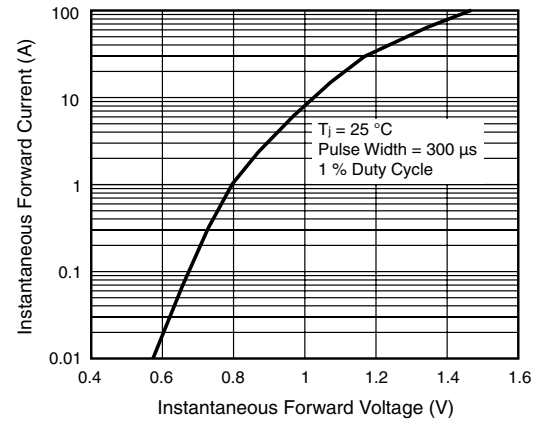

Figure 5. Typical Instantaneous Forward Characteristics Per Diode

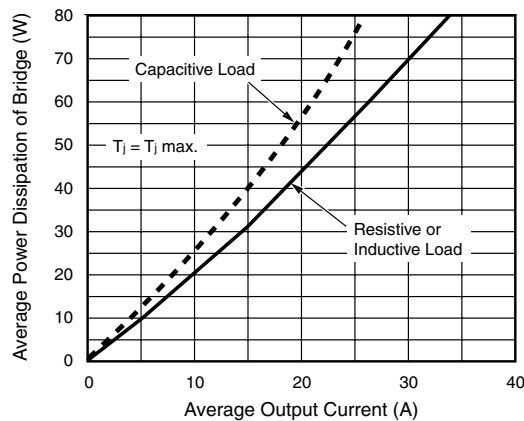

Figure 3. Maximum Power Dissipation

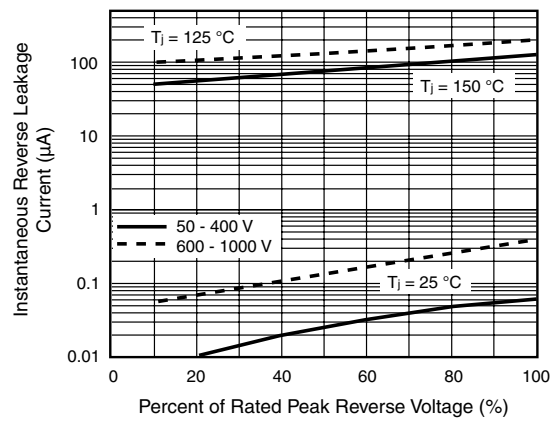

Figure 6. Typical Reverse Leakage Characteristics Per Diode

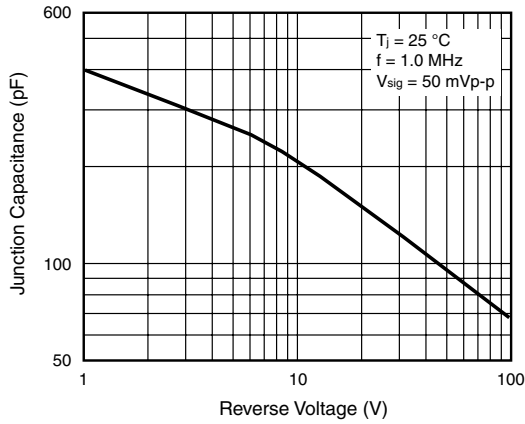

Figure 7. Typical Junction Capacitance Per Diode

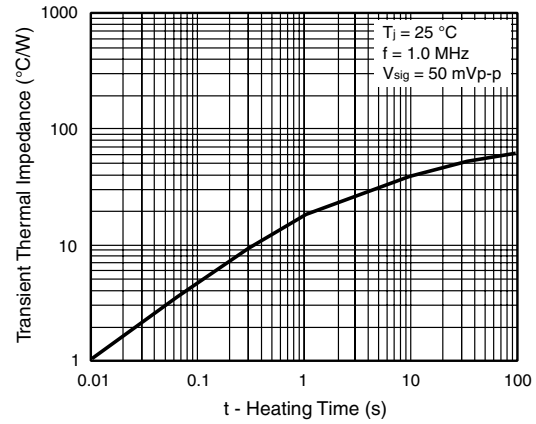
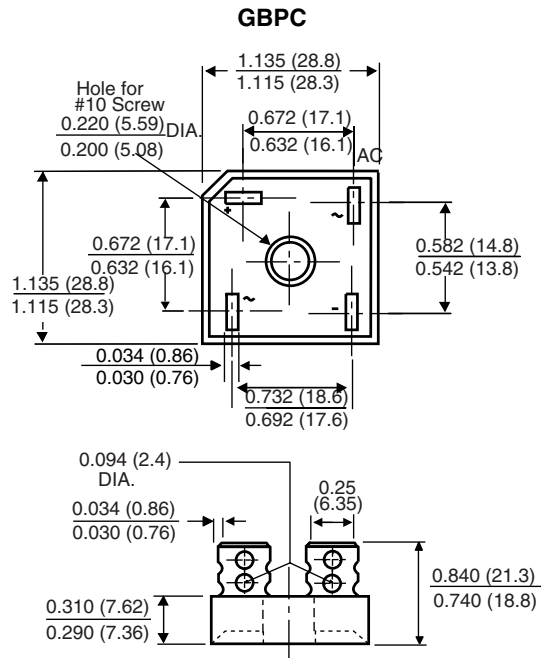
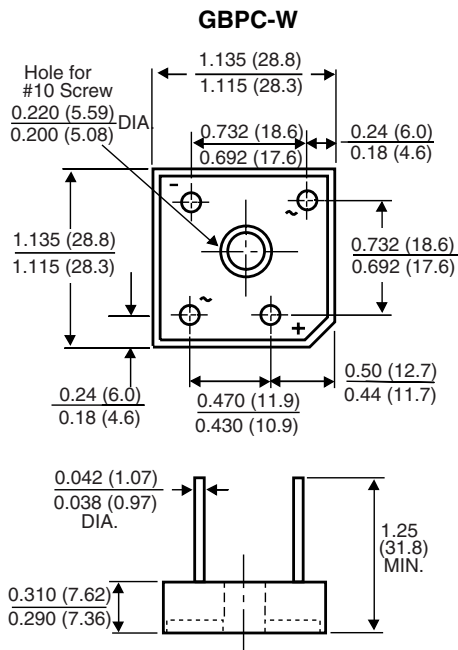

Figure 8. Typical Transient Thermal Impedance Per Diode

## PACKAGE OUTLINE DIMENSIONS in inches (millimeters)





## Notice

Specifications of the products displayed herein are subject to change without notice. Vishay Intertechnology, Inc., or anyone on its behalf, assumes no responsibility or liability for any errors or inaccuracies.

Information contained herein is intended to provide a product description only. No license, express or implied, by estoppel or otherwise, to any intellectual property rights is granted by this document. Except as provided in Vishay's terms and conditions of sale for such products, Vishay assumes no liability whatsoever, and disclaims any express or implied warranty, relating to sale and/or use of Vishay products including liability or warranties relating to fitness for a particular purpose, merchantability, or infringement of any patent, copyright, or other intellectual property right.

The products shown herein are not designed for use in medical, life-saving, or life-sustaining applications. Customers using or selling these products for use in such applications do so at their own risk and agree to fully indemnify Vishay for any damages resulting from such improper use or sale.