

Fixed frequency VIPer™ plus family

Features

- 800 V avalanche rugged power section
- PWM operation with frequency jittering for low EMI
- Operating frequency:
 - 60 kHz for L type
 - 115 kHz for H type
- Standby power < 50 mW at 265 V_{AC}
- Limiting current with adjustable set point
- On-board soft-start
- Safe auto-restart after a fault condition
- Hysteretic thermal shutdown

Application

- Auxiliary power supply for appliances
- Power metering
- LED drivers
- SMPS for set-top boxes, DVD players and recorders

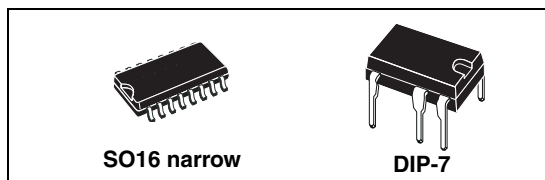

Description

The device is an off-line converter with an 800 V avalanche ruggedness power section, a PWM controller, user defined overcurrent limit, protection against feedback network disconnection, hysteretic thermal protection, soft start up and safe auto restart after any fault condition.

Advance frequency jittering reduces EMI filter cost. Burst mode operation and the devices very low consumption both help to meet the standard set by energy saving regulations.

Figure 1. Typical topology ($V_{OUT} \leq V_{DCCSon}$)

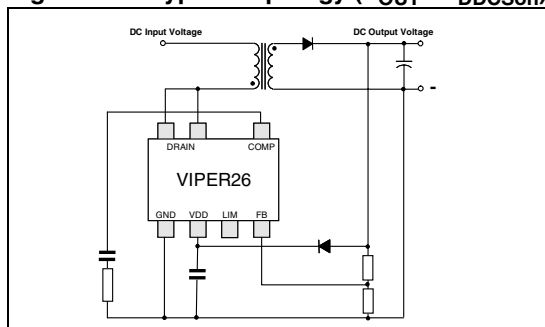

Table 1. Device summary

Order codes	Package	Packaging
VIPER26LN	DIP-7	Tube
VIPER26HN		Tube
VIPER26HD	SO16 narrow	Tape and reel
VIPER26HDTR		Tube
VIPER26LD		Tape and reel
VIPER26LDTR		Tube

Contents

1	Block diagram	3
2	Typical power	3
3	Pin settings	4
4	Electrical data	5
	4.1 Maximum ratings	5
	4.2 Thermal data	5
	4.3 Electrical characteristics	6
5	Typical electrical characteristics	8
6	Typical circuits	10
7	Power section	13
8	High voltage current generator	13
9	Oscillator	14
10	Soft start-up	14
11	Adjustable current limit set point	14
12	FB pin and COMP pin	15
13	Burst mode	16
14	Automatic auto restart after overload or short-circuit	17
15	Open loop failure protection	18
16	Package mechanical data	20
17	Revision history	24

1 Block diagram

Figure 2. Block diagram

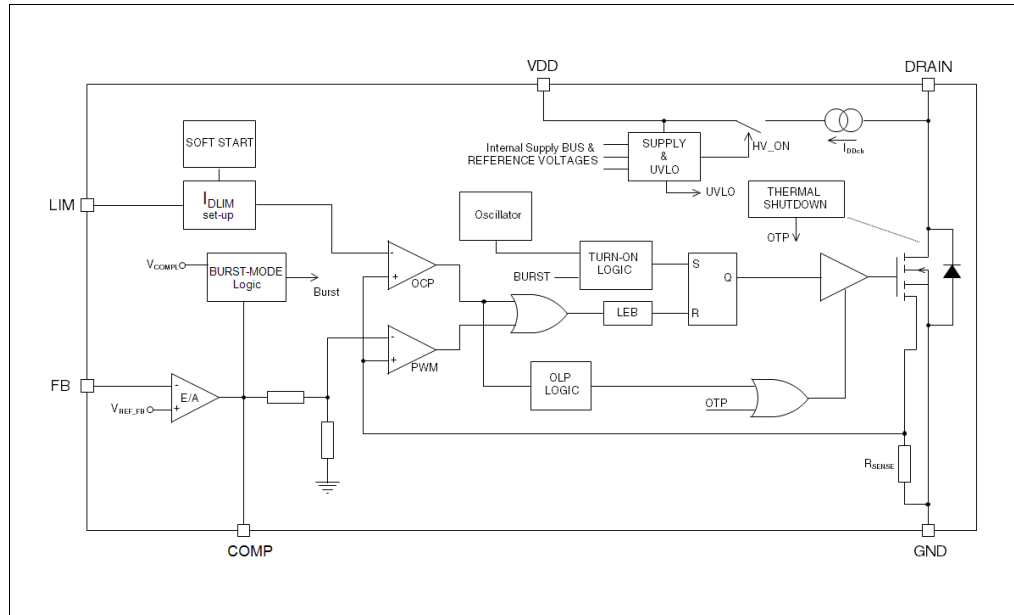

2 Typical power

Table 2. Typical power

Part number	230 V _{AC}		85-265 V _{AC}	
	Adapter ⁽¹⁾	Open frame ⁽²⁾	Adapter ⁽¹⁾	Open frame ⁽²⁾
VIPER26	18 W	20 W	10 W	12 W

1. Typical continuous power in non ventilated enclosed adapter measured at 50 °C ambient.
2. Maximum practical continuous power in an open frame design at 50 °C ambient, with adequate heat sinking.

3 Pin settings

Figure 3. Connection diagram (top view)

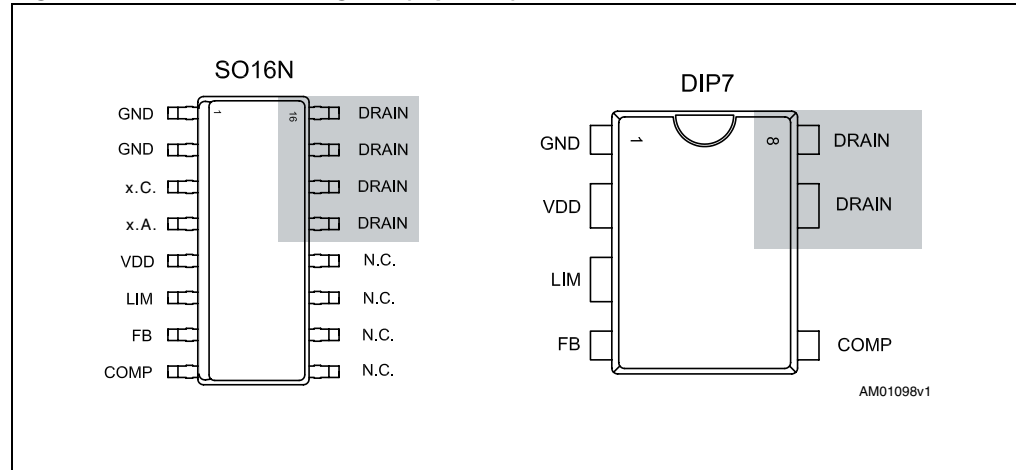

Note: The copper area for heat dissipation has to be designed under the DRAIN pins.

Table 3. Pin description

Pin n.		Name	Function
DIP-7	SO16		
1	1-2	GND	Connected to the source of the internal power MOSFET and controller ground reference.
-	4	N.A.	Not available for user. It can be connected to GND (pins 1-2) or left not connected.
2	5	VDD	Supply voltage of the control section. This pin provides the charging current of the external capacitor.
3	6	LIM	This pin allows setting the drain current limitation. The limit can be reduced by connecting an external resistor between this pin and GND. Pin left open if default drain current limitation is used.
4	7	FB	Inverting input of the internal trans conductance error amplifier. Connecting the converter output to this pin through a single resistor results in an output voltage equal to the error amplifier reference voltage (See V_{FB_REF} on Table 7). An external resistors divider is required for higher output voltages.
5	8	COMP	Output of the internal trans conductance error amplifier. The compensation network have to be placed between this pin and GND to achieve stability and good dynamic performance of the voltage control loop. The pin is used also to directly control the PWM with an optocoupler. The linear voltage range extends from V_{COMPL} to V_{COMPH} (Table 7).
7,8	13-16	DRAIN	High voltage drain pin. The built-in high voltage switched start-up bias current is drawn from this pin too. Pins connected to the metal frame to facilitate heat dissipation.

4 Electrical data

4.1 Maximum ratings

Table 4. Absolute maximum ratings

Symbol	Pin (DIP-7)	Parameter	Value		Unit
			Min	Max	
V _{DRAIN}	7, 8	Drain-to-source (ground) voltage		800	V
E _{AV}	7, 8	Repetitive avalanche energy (limited by T _J = 150 °C)		5	mJ
I _{AR}	7, 8	Repetitive avalanche current (limited by T _J = 150 °C)		1.5	A
I _{DRAIN}	7, 8	Pulse drain current (limited by T _J = 150 °C)		3	A
V _{COMP}	5	Input pin voltage	-0.3	3.5	V
V _{FB}	4	Input pin voltage	-0.3	4.8	V
V _{LIM}	3	Input pin voltage	-0.3	2.4	V
V _{DD}	2	Supply voltage	-0.3	Self limited	V
I _{DD}	2	Input current		20	mA
P _{TOT}		Power dissipation at T _A < 40 °C (DIP-7)		1	W
		Power dissipation at T _A < 60 °C (SO16N)		1.5	W
T _J		Operating junction temperature range	-40	150	°C
T _{STG}		Storage temperature	-55	150	°C

4.2 Thermal data

Table 5. Thermal data

Symbol	Parameter	Max value		Unit
		SO16N	DIP-7	
R _{thJP}	Thermal resistance junction pin (Dissipated power = 1 W)	25	35	°C/W
R _{thJA}	Thermal resistance junction ambient (Dissipated power = 1 W)	60	100	°C/W
R _{thJA}	Thermal resistance junction ambient ⁽¹⁾ (Dissipated power = 1 W)	50	80	°C/W

1. When mounted on a standard single side FR4 board with 100 mm² (0.155 sq in) of Cu (35 µm thick)

4.3 Electrical characteristics

($T_J = -25$ to 125 °C, $V_{DD} = 14$ V ^(a); unless otherwise specified)

Table 6. Power section

Symbol	Parameter	Test condition	Min	Typ	Max	Unit
V_{BVDSS}	Break-down voltage	$I_{DRAIN} = 1$ mA, $V_{COMP} = GND$, $T_J = 25$ °C	800			V
I_{OFF}	OFF state drain current	$V_{DRAIN} = \text{max rating}$, $V_{COMP} = GND$			60	μA
$R_{DS(on)}$	Drain-source on state resistance	$I_{DRAIN} = 0.2$ A, $T_J = 25$ °C			7	Ω
		$I_{DRAIN} = 0.2$ A, $T_J = 125$ °C			14	Ω
C_{OSS}	Effective (energy related) output capacitance	$V_{DRAIN} = 0$ to 640 V		40		pF

Table 7. Supply section

Symbol	Parameter	Test condition	Min	Typ	Max	Unit
Voltage						
V_{DRAIN_START}	Drain-source start voltage		60	80	100	V
I_{DDch1}	Charging current during the start up	$V_{DRAIN} = 100$ V to 640 V, $V_{DD} = 4$ V	-0.6		-1.8	mA
I_{DDch2}	Charging current during the autorestart	$V_{DRAIN} = 100$ V to 640 V, $V_{DD} = 9$ V falling edge	-7		-13	mA
V_{DD}	Operating voltage range		11.5		23.5	V
$V_{DDclamp}$	V_{DD} clamp voltage	$I_{DD} = 15$ mA	23.5			V
V_{DDon}	V_{DD} start up threshold		12	13	14	V
V_{DDCSon}	VDD on internal high voltage current generator threshold		9.5	10.5	11.5	V
V_{DDoff}	V_{DD} under voltage shutdown threshold		7	8	9	V
Current						
I_{DD0}	Operating supply current, not switching	$F_{OSC} = 0$ kHz, $V_{COMP} = GND$			0.6	mA
I_{DD1}	Operating supply current, switching	$V_{DRAIN} = 120$ V, $F_{SW} = 60$ kHz			2.5	mA
		$V_{DRAIN} = 120$ V, $F_{SW} = 115$ kHz			3.5	mA
I_{DDoff}	Operating supply current with $V_{DD} < V_{DDoff}$	$V_{DD} < V_{DDoff}$			0.35	mA
I_{DDol}	Open loop failure current threshold	$V_{DD} = V_{DDclamp}$ $V_{COMP} = 3.3$ V,	4			mA

a. Adjust V_{DD} above V_{DDon} startup threshold before setting to 14 V

Table 8. Controller section

Symbol	Parameter	Test condition	Min	Typ	Max	Unit
Error amplifier						
V_{REF_FB}	FB reference voltage		3.2	3.3	3.4	V
$I_{FB_PULL\ UP}$	Current pull up			-1		μ A
G_M	Trans conductance			2		mA/V
Current setting (LIM) pin						
V_{LIM_LOW}	Low level clamp voltage	$I_{LIM} = -100 \mu$ A		0.5		V
Compensation (COMP) pin						
V_{COMPH}	Upper saturation limit	$T_J = 25 \text{ }^\circ\text{C}$		3		V
V_{COMPL}	Burst mode threshold	$T_J = 25 \text{ }^\circ\text{C}$	1	1.1	1.2	V
V_{COMPL_HYS}	Burst mode hysteresis	$T_J = 25 \text{ }^\circ\text{C}$		40		mV
H_{COMP}	$\Delta V_{COMP} / \Delta I_{DRAIN}$			3		V/A
$R_{COMP(DYN)}$	Dynamic resistance	$V_{FB} = GND$		15		k Ω
I_{COMP}	Source / sink current	$V_{FB} > 100 \text{ mV}$		150		μ A
	Max source current	$V_{COMP} = GND, V_{FB} = GND$		220		μ A
Current limitation						
I_{Dlim}	Drain current limitation	$I_{LIM} = -10 \mu$ A, $V_{COMP} = 3.3 \text{ V}$, $T_J = 25 \text{ }^\circ\text{C}$	0.66	0.7	0.74	A
t_{SS}	Soft-start time			8.5		ms
T_{ON_MIN}	Minimum turn ON time				480	ns
I_{Dlim_bm}	Burst mode current limitation	$V_{COMP} = V_{COMPL}$		145		mA
Overload						
t_{OVL}	Overload time			50		ms
$t_{RESTART}$	Restart time after fault			1		s
Oscillator section						
F_{OSC}	Switching frequency	VIPER26L	54	60	66	kHz
		VIPER26H	103	115	127	kHz
F_D	Modulation depth	$F_{OSC} = 60 \text{ kHz}$		± 4		kHz
		$F_{OSC} = 115 \text{ kHz}$		± 8		kHz
F_M	Modulation frequency			230		Hz
D_{MAX}	Maximum duty cycle		70		80	%
Thermal shutdown						
T_{SD}	Thermal shutdown temperature		150	160		$^\circ\text{C}$
T_{HYST}	Thermal shutdown hysteresis			30		$^\circ\text{C}$

5 Typical electrical characteristics

Figure 4. I_{DLIM} vs T_J

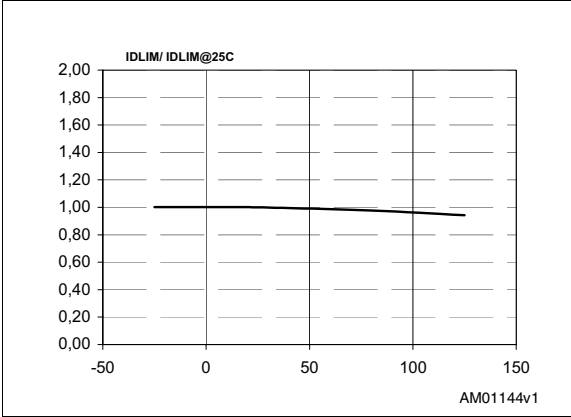

Figure 5. F_{OSC} vs T_J

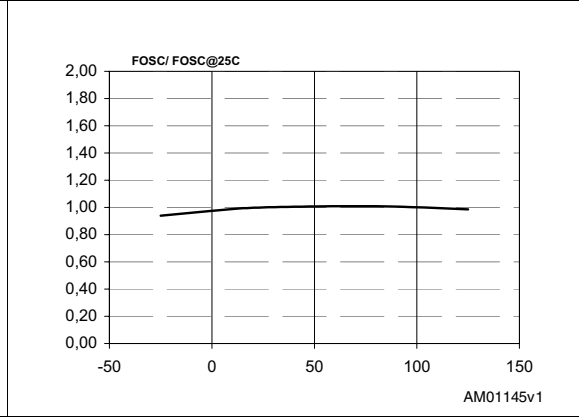

Figure 6. V_{DRAIN_START} vs T_J

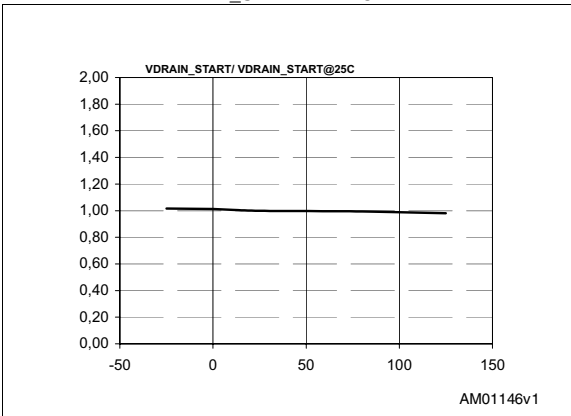

Figure 7. H_{COMP} vs T_J

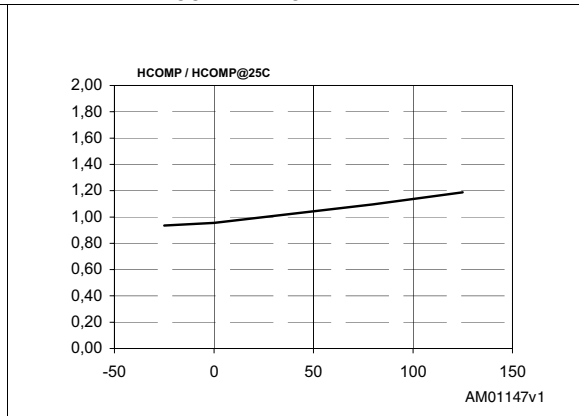

Figure 8. G_M vs T_J

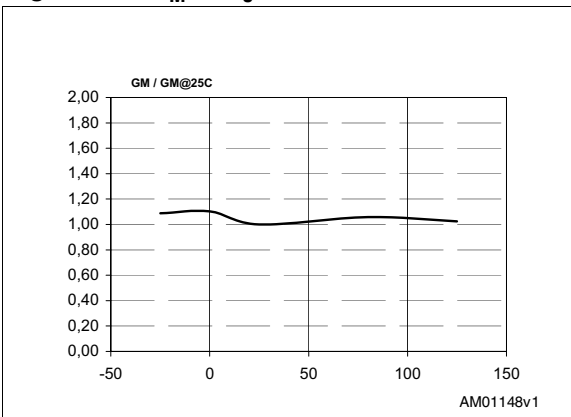

Figure 9. V_{REF_FB} vs T_J

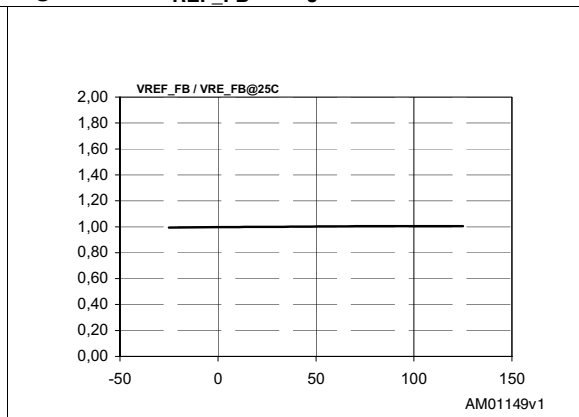

Figure 10. I_{COMP} vs T_J

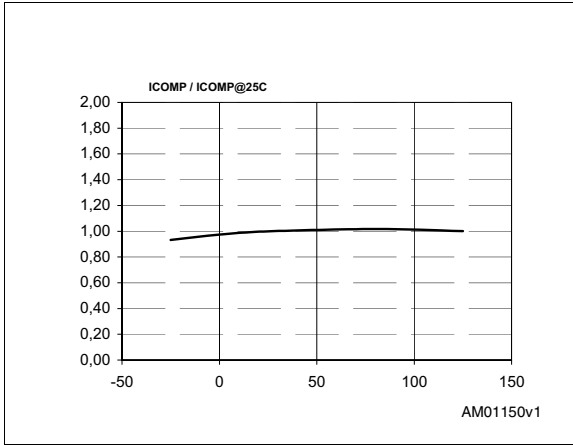

Figure 11. Operating supply current (no switching) vs T_J

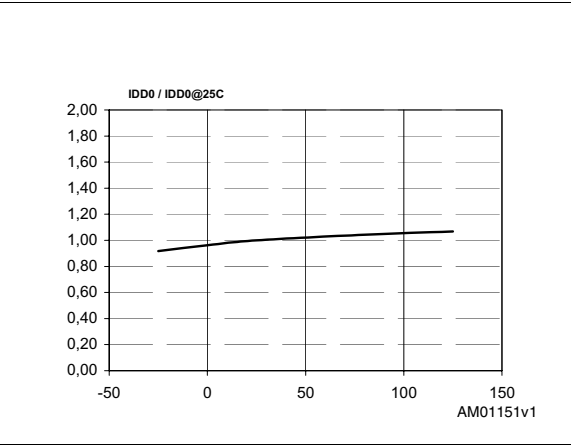

Figure 12. Operating supply current (switching) vs T_J

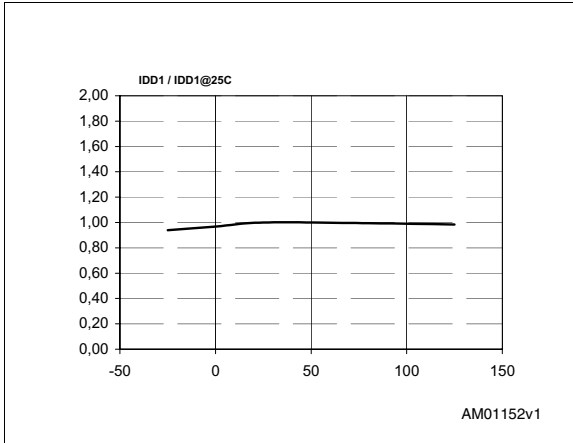

Figure 13. I_{DLIM} vs R_{LIM}

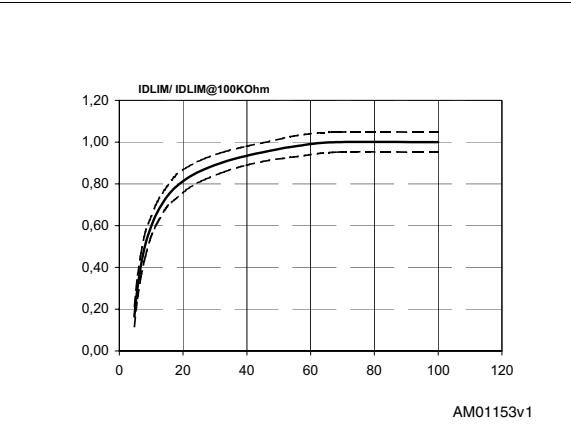

Figure 14. Power MOSFET on-resistance vs T_J Figure 15. Power MOSFET break down voltage vs T_J

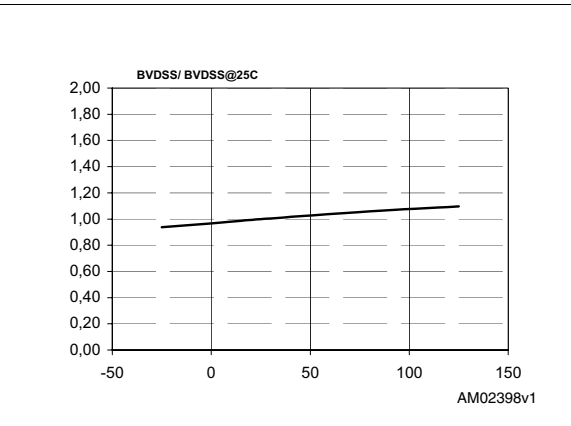
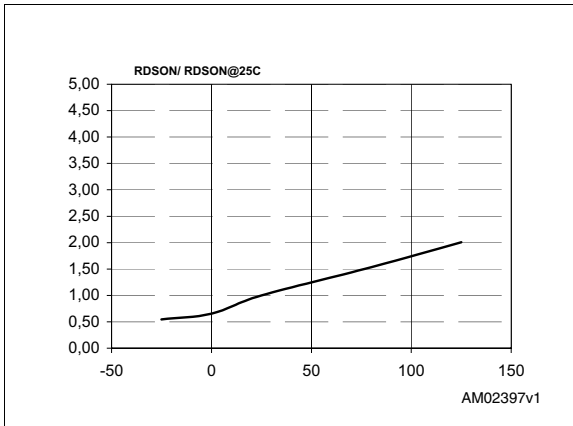
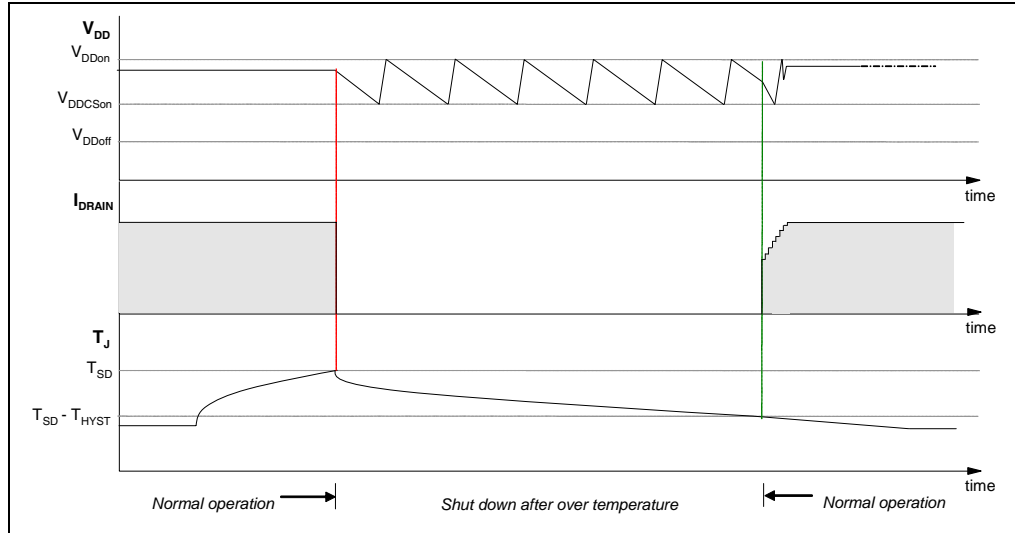

Figure 16. Thermal shutdown



6 Typical circuits

Figure 17. Buck converter ($V_{OUT} > V_{DDCSon}$)

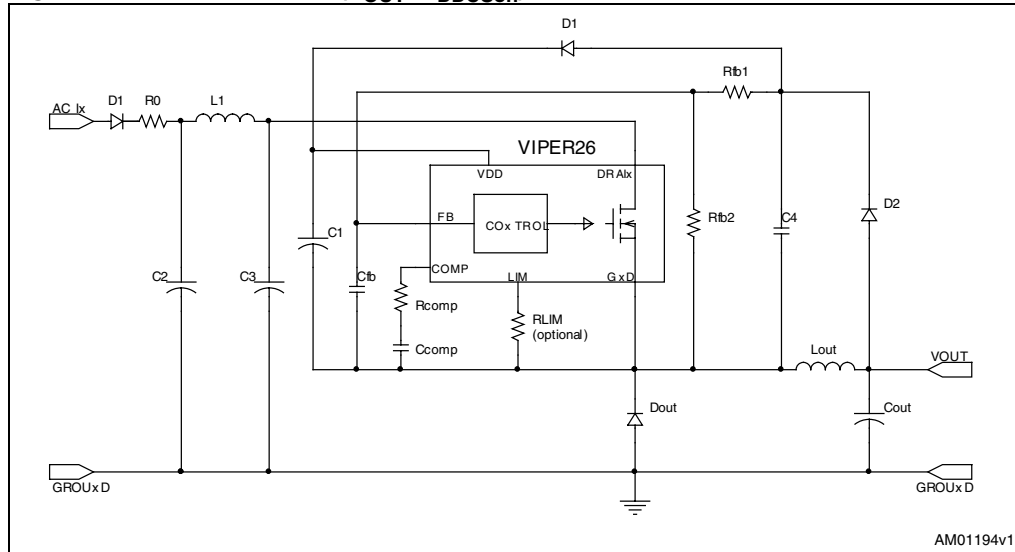

Figure 18. Fly-back converter (isolated)

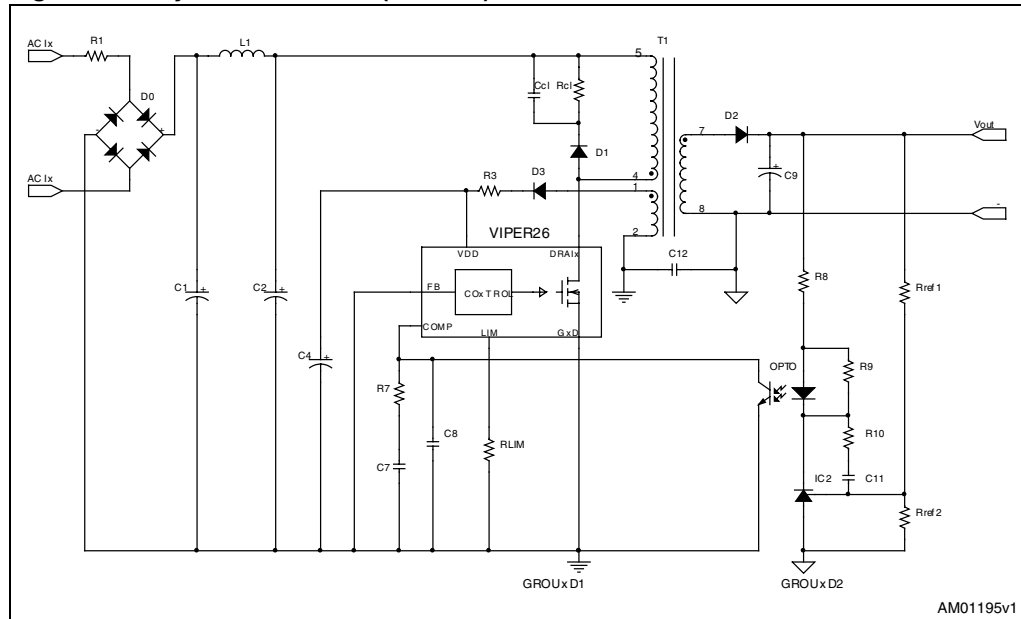

Figure 19. Flyback converter (primary regulation)

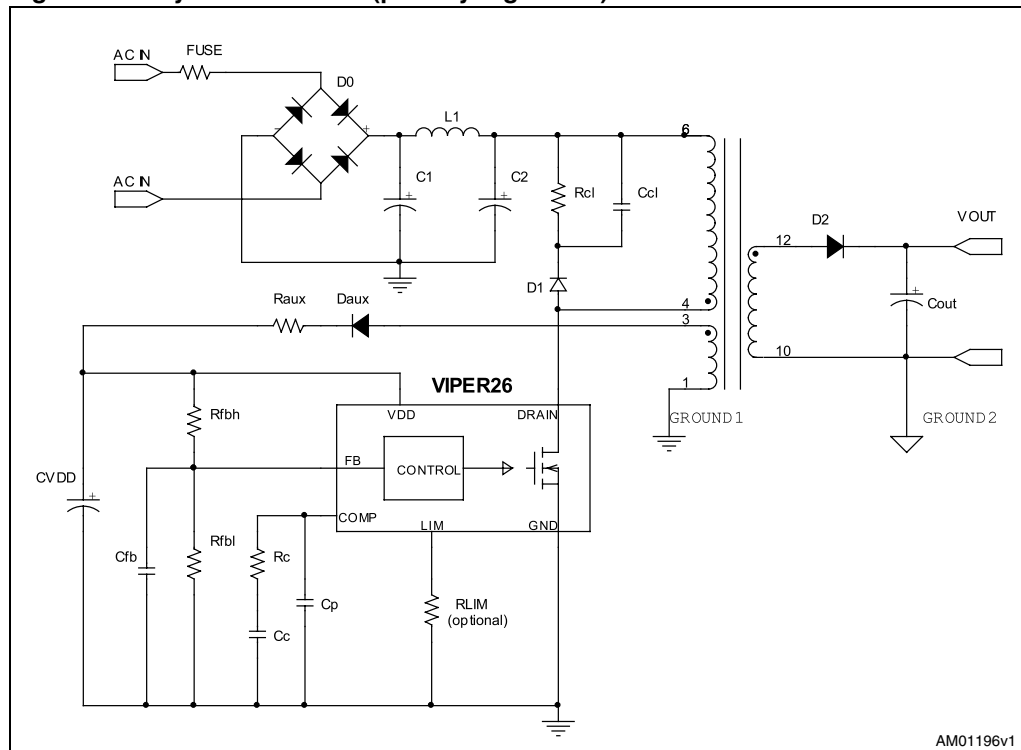
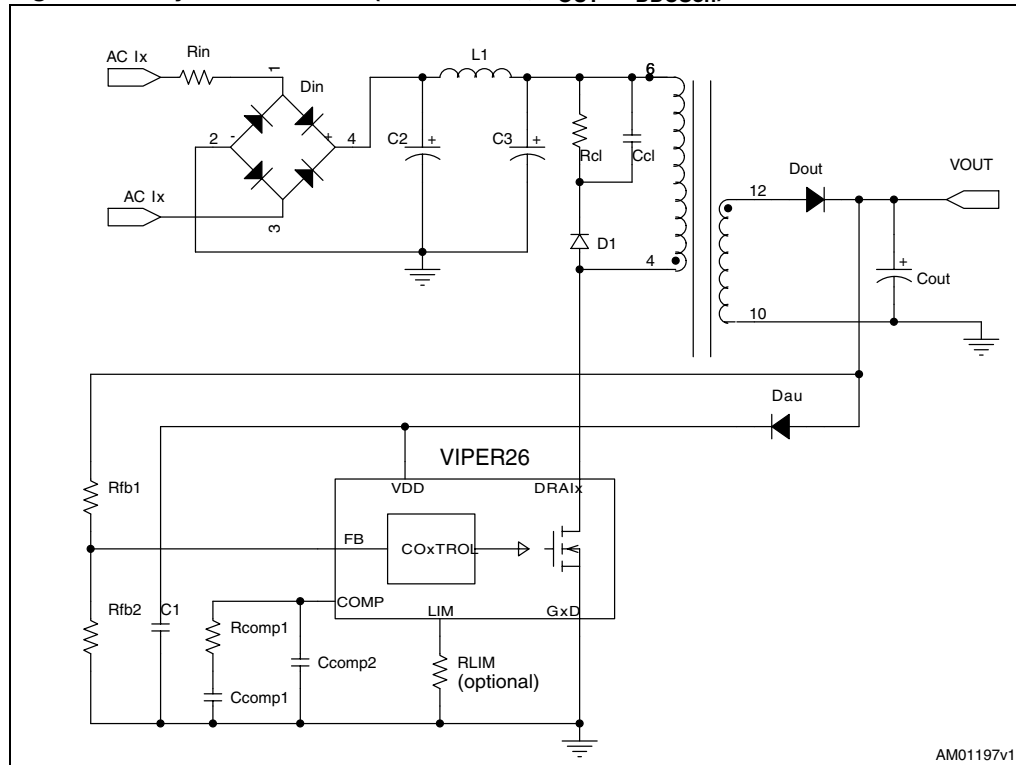
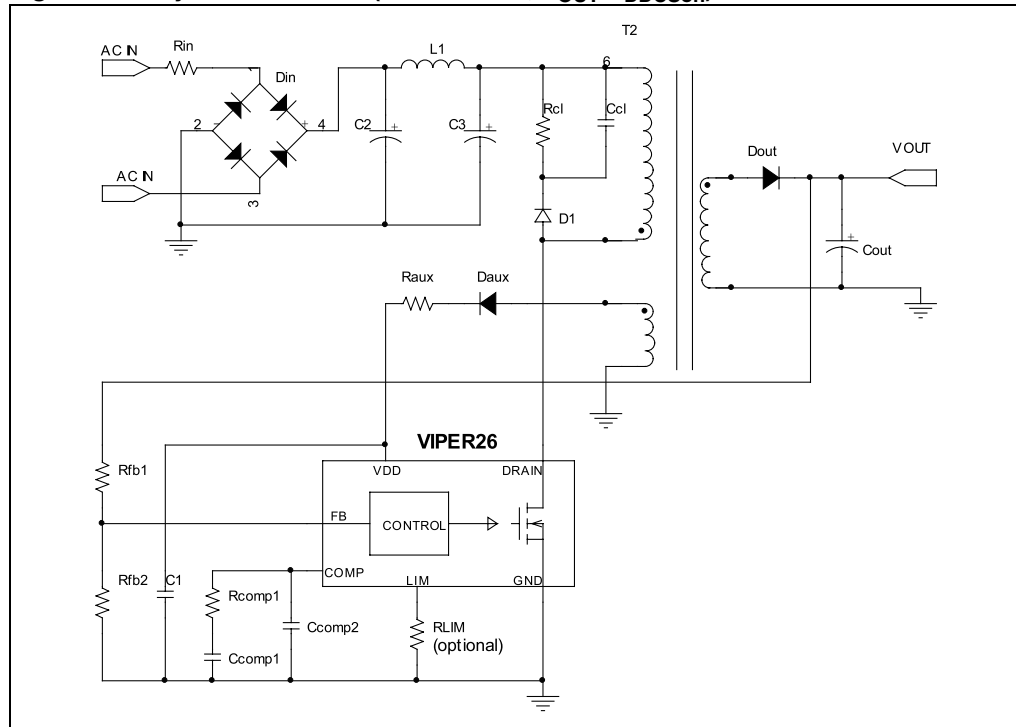

Figure 20. Flyback converter (non isolated, $V_{OUT} \approx V_{DDCS_{on}}$)



AM01197v1

Figure 21. Flyback converter (non isolated, $V_{OUT} \approx V_{DDCS_{on}}$)



7 Power section

The power section is implemented with an n-channel power MOSFET with a breakdown voltage of 800 V min. and a typical $R_{DS(on)}$ of 7 Ω . It includes a SenseFET structure to allow a virtually lossless current sensing and the thermal sensor.

The gate driver of the power MOSFET is designed to supply a controlled gate current during both turn-ON and turn-OFF in order to minimize common mode EMI. During UVLO conditions, an internal pull-down circuit holds the gate low in order to ensure that the power MOSFET cannot be turned ON accidentally.

8 High voltage current generator

The high voltage current generator is supplied by the DRAIN pin. At the first start up of the converter, it is enabled when the voltage across the input bulk capacitor reaches the V_{DRAIN_START} threshold, sourcing the I_{DDch1} current (see [Table 7 on page 6](#)); as the V_{DD} voltage reaches the V_{DDon} start-up threshold, the power section starts switching and the high voltage current generator is turned OFF. The VIPer26 is powered by the external source. After the start-up, the auxiliary winding or the diode connected to the output voltage have to power the VDD capacitor with voltage higher than V_{DDCSon} threshold (see [Table 7 on page 6](#)). During the switching, the internal current source is disabled and the consumptions are minimized. In case of fault the switching is stopped and the device is self biased by the internal high voltage current source; it is activated between the levels V_{DDCSon} and V_{DDon} delivering the current I_{DDch2} to the V_{DD} capacitor during the MOSFET off time, see [Figure 22 on page 13](#).

At converter power-down, the V_{DD} voltage drops and the converter activity stops as it falls below V_{DDoff} threshold (see [Table 7 on page 6](#)).

Figure 22. Power on and power off

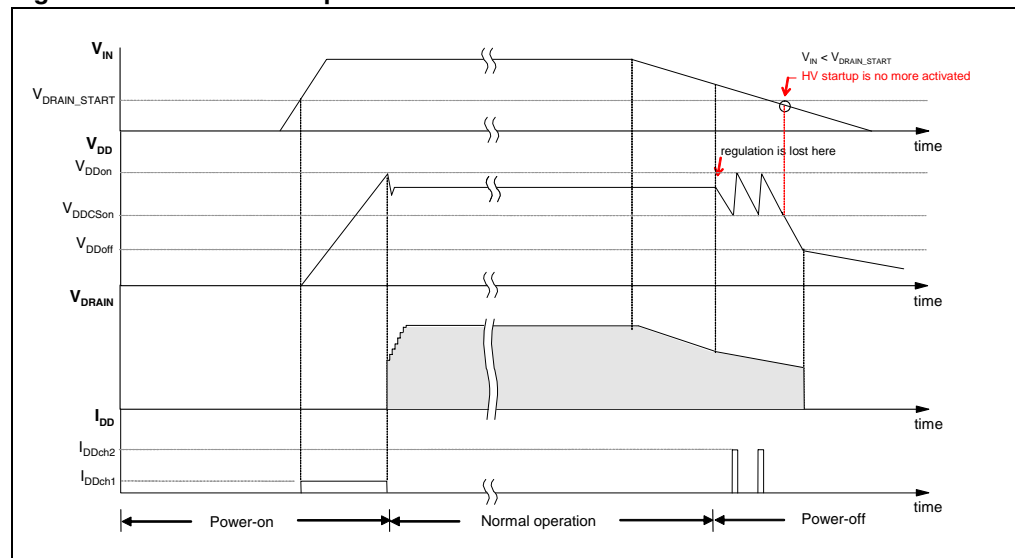

9 Oscillator

The switching frequency is internally fixed at 60 kHz (VIPER26LN or LD) or 115 kHz (VIPER26HN or HD).

In both cases the switching frequency is modulated by approximately ± 4 kHz (60 kHz version) or ± 8 kHz (115 kHz version) at 230 Hz (typical) rate, so that the resulting spread-spectrum action distributes the energy of each harmonic of the switching frequency over a number of sideband harmonics having the same energy on the whole but smaller amplitudes.

10 Soft start-up

During the converters' start-up phase, the soft-start function progressively increases the cycle-by-cycle drain current limit, up to the default value I_{Dlim} . By this way the drain current is further limited and the output voltage is progressively increased reducing the stress on the secondary diode. The soft-start time is internally fixed to t_{SS} , see typical value on [Table 8 on page 7](#), and the function is activated for any attempt of converter start-up and after a fault event.

This function helps prevent transformers' saturation during start-up and short-circuit.

11 Adjustable current limit set point

The VIPer26 includes a current mode PWM controller: cycle by cycle the drain current is sensed through the integrated resistor R_{SENSE} and the voltage is applied to the non inverting input of the PWM comparator, see [Figure 2 on page 3](#). As soon as the sensed voltage is equal to the voltage derived from the COMP pin, the power MOSFET is switched OFF.

In parallel with the PWM operations, the comparator OCP, see [Figure 2 on page 3](#), checks the level of the drain current and switch OFF the power MOSFET in case the current is higher than the threshold I_{Dlim} , see [Table 8 on page 7](#).

The level of the drain current limit, I_{Dlim} , can be reduced depending from the sunk current from the pin LIM. The resistor R_{LIM} , between LIM and GND pins, fixes the current sunk and than the level of the current limit, I_{Dlim} , see [Figure 13 on page 9](#).

When the LIM pin is left open or if the R_{LIM} has an high value (i.e. > 80 k Ω) the current limit is fixed to its default value, I_{Dlim} , as reported on [Table 8 on page 7](#).

12 FB pin and COMP pin

The device can be used both in non-isolated and in isolated topology. In case of non-isolated topology, the feedback signal from the output voltage is applied directly to the FB pin as inverting input of the internal error amplifier having the reference voltage, V_{REF_FB} , see the [Table 8 on page 7](#).

The output of the error amplifier sources and sinks the current, I_{COMP} respectively to and from the compensation network connected on the COMP pin. This signal is then compared, in the PWM comparator, with the signal coming from the SenseFET; the power MOSFET is switched off when the two values are the same on cycle by cycle basis. See the [Figure 2 on page 3](#) and the [Figure 23 on page 15](#).

When the power supply output voltage is equal to the error amplifier reference voltage, V_{REF_FB} , a single resistor has to be connected from the output to the FB pin. For higher output voltages the external resistor divider is needed. If the voltage on FB pin is accidentally left floating, an internal pull-up protects the controller.

The output of the error amplifier is externally accessible through the COMP pin and it's used for the loop compensation: usually an RC network.

As reported on [Figure 23 on page 15](#), in case of isolated power supply, the internal error amplifier has to be disabled (FB pin shorted to GND). In this case an internal resistor is connected between an internal reference voltage and the COMP pin, see the [Figure 23 on page 15](#). The current loop has to be closed on the COMP pin through the opto-transistor in parallel with the compensation network. The V_{COMP} dynamics ranges is between V_{COMPL} and V_{COMPH} as reported on [Figure 24 on page 16](#).

When the voltage V_{COMP} drops below the voltage threshold V_{COMPL} , the converter enters burst mode, see [Section 13 on page 16](#).

When the voltage V_{COMP} rises above the V_{COMPH} threshold, the peak drain current will reach its limit, as well as the deliverable output power

Figure 23. Feedback circuit

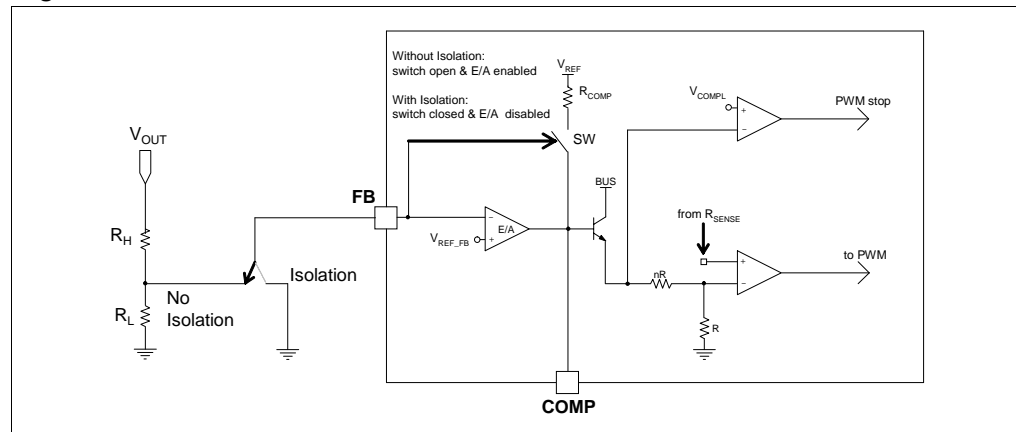
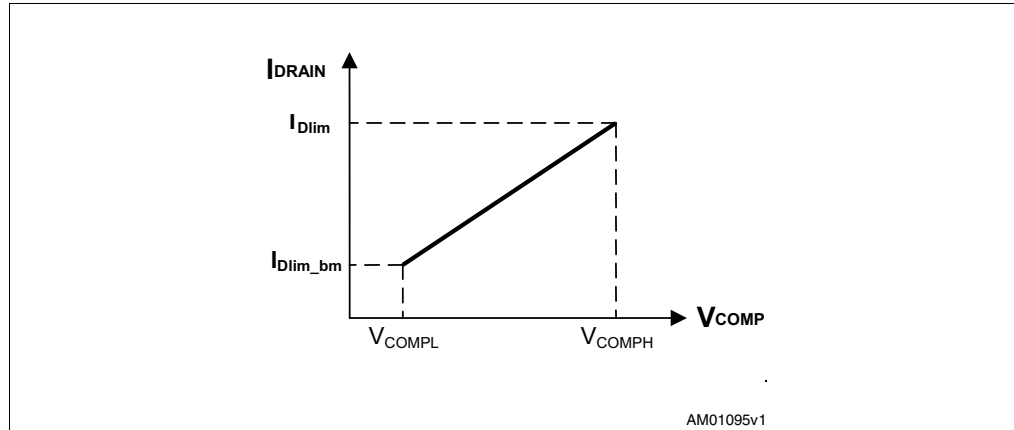
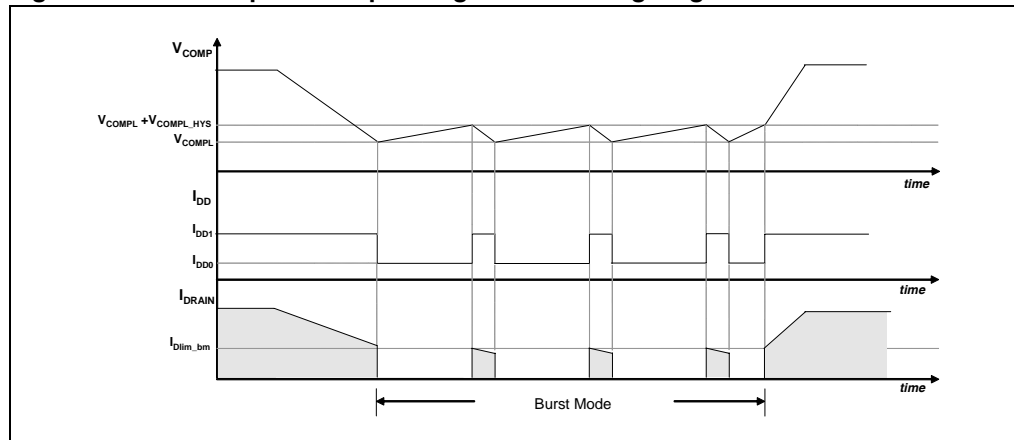

Figure 24. COMP pin voltage versus I_{DLIM} 

13 Burst mode

When the voltage V_{COMP} drops below the threshold, V_{COMPL} , the power MOSFET is kept in OFF state and the consumption is reduced to I_{DD0} current, as reported on [Table 7 on page 6](#). As reaction at the energy delivery stop, the V_{COMP} voltage increases and as soon as it exceeds the threshold $V_{COMPL} + V_{COMPL_HYS}$, the converter starts switching again with consumption level equal to I_{DD1} current. This ON-OFF operation mode, referred to as “burst mode” and reported on [Figure 25 on page 16](#), reduces the average frequency, which can go down even to a few hundreds hertz, thus minimizing all frequency-related losses and making it easier to comply with energy saving regulations. During the burst mode, the drain current limit is reduced to the value I_{Dlim_bm} (reported on [Table 8 on page 7](#)) in order to avoid the audible noise issue.

Figure 25. Load-dependent operating modes: timing diagrams



14 Automatic auto restart after overload or short-circuit

The overload protection is implemented in automatic way using the integrated up-down counter. Every cycle, it is incremented or decremented depending if the current logic detects the limit condition or not. The limit condition is the peak drain current, I_{Dlim} , reported on [Table 8 on page 7](#) or the one set by the user through the R_{LIM} resistor, as reported in [Figure 13 on page 9](#).

After the reset of the counter, if the peak drain current is continuously equal to the level I_{Dlim} , the counter will be incremented till the fixed time, t_{OVL} , after that will be disabled the power MOSFET switch ON. It will be activated again, through the soft start, after the $t_{RESTART}$ time, see the [Figure 26 on page 17](#) and the mentioned time values on [Table 8 on page 7](#).

In case of overload or short-circuit event, the power MOSFET switching will be stopped after a time that depends from the counter and that can be as maximum equal to t_{OVL} . The protection will occur in the same way until the overload condition is removed, see [Figure 26 on page 17](#).

This protection ensures restart attempts of the converter with low repetition rate, so that it works safely with extremely low power throughput and avoiding the IC overheating in case of repeated overload events.

If the overload is removed before the protection tripping, the counter will be decremented cycle by cycle down to zero and the IC will not be stopped.

Figure 26. Timing diagram: OLP sequence

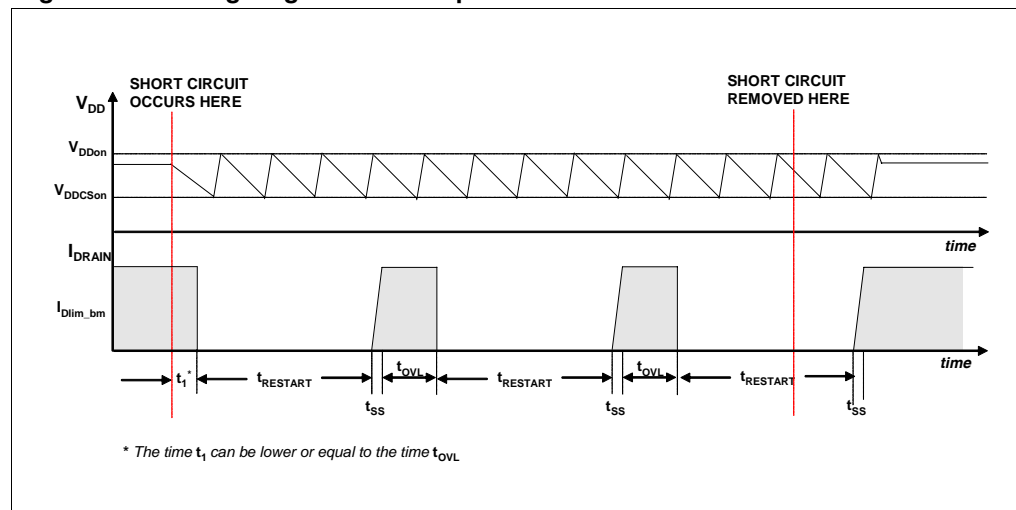

15 Open loop failure protection

In case the power supply is built in fly-back topology and the VIPer26 is supplied by an auxiliary winding, as shown in [Figure 27 on page 18](#) and [Figure 28 on page 19](#), the converter is protected against feedback loop failure or accidental disconnections of the winding.

The following description is applicable for the schematics of [Figure 27 on page 18](#) and [Figure 28 on page 19](#), respectively the non-isolated fly-back and the isolated fly-back.

If R_H is opened or R_L is shorted, the VIPer26 works at its drain current limitation. The output voltage, V_{OUT} , will increase and so the auxiliary voltage, V_{AUX} , which is coupled with the output through the secondary-to-auxiliary turns ratio.

As the auxiliary voltage increases up to the internal V_{DD} active clamp, $V_{DDclamp}$ (the value is reported on [Table 8 on page 7](#)) and the clamp current injected on VDD pin exceeds the latch threshold, I_{DDol} (the value is reported on [Table 8 on page 7](#)), a fault signal is internally generated.

In order to distinguish an actual malfunction from a bad auxiliary winding design, both the above conditions (drain current equal to the drain current limitation and current higher than I_{DDol} through VDD clamp) have to be verified to reveal the fault.

If R_L is opened or R_H is shorted, the output voltage, V_{OUT} , will be clamped to the reference voltage V_{REF_FB} (in case of non isolated fly-back) or to the external TL voltage reference (in case of isolated fly-back).

Figure 27. FB pin connection for non-isolated fly-back

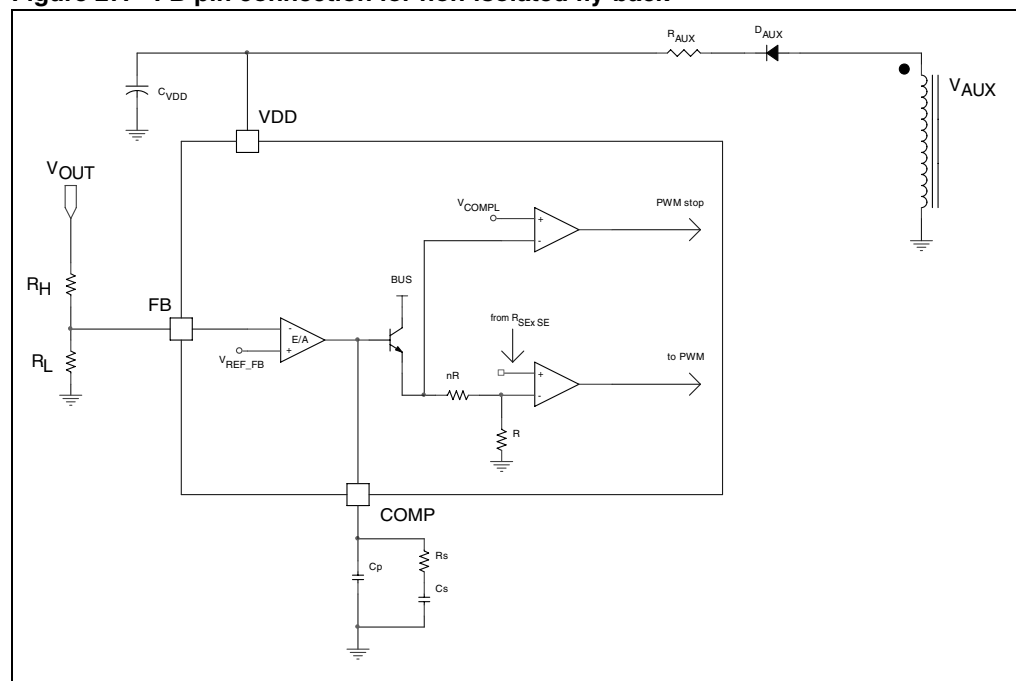
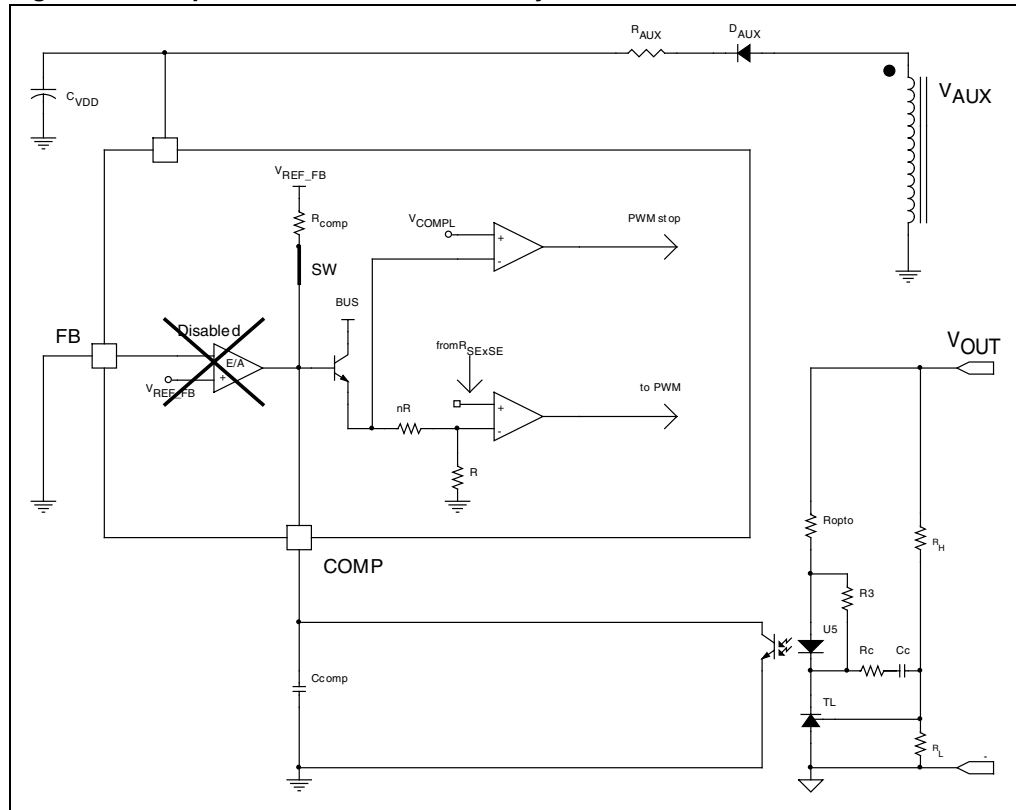

Figure 28. FB pin connection for isolated fly-back



16 Package mechanical data

In order to meet environmental requirements, ST offers these devices in different grades of ECOPACK[®] packages, depending on their level of environmental compliance. ECOPACK[®] specifications, grade definitions and product status are available at: www.st.com. ECOPACK[®] is an ST trademark.

Table 9. DIP-7 mechanical data

Dim.	mm		
	Typ	Min	Max
A			5.33
A1		0.38	
A2	3.30	2.92	4.95
b	0.46	0.36	0.56
b2	1.52	1.14	1.78
c	0.25	0.20	0.36
D	9.27	9.02	10.16
E	7.87	7.62	8.26
E1	6.35	6.10	7.11
e	2.54		
eA	7.62		
eB			10.92
L	3.30	2.92	3.81
M	2.508		
N	0.50	0.40	0.60
N1			0.60
O	0.548		

Figure 29. DIP-7 package dimensions

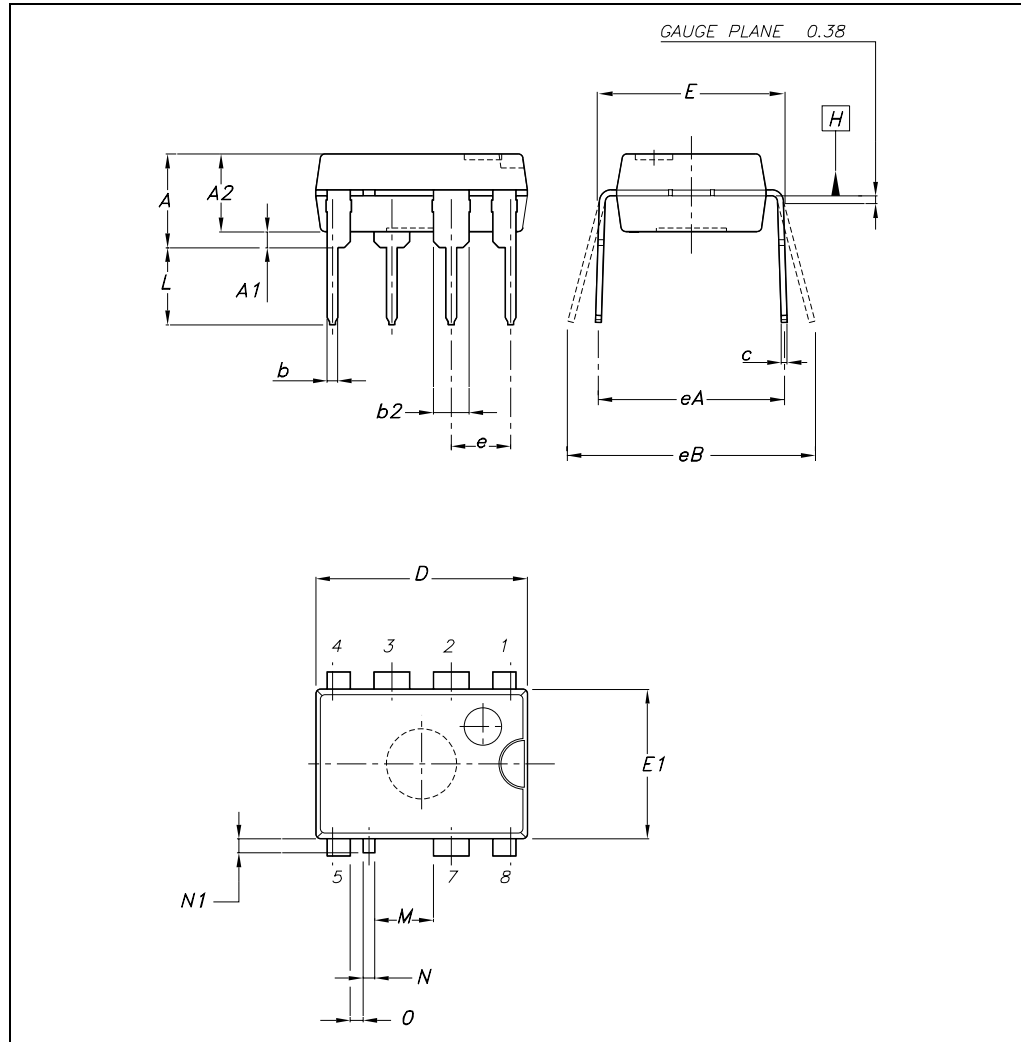
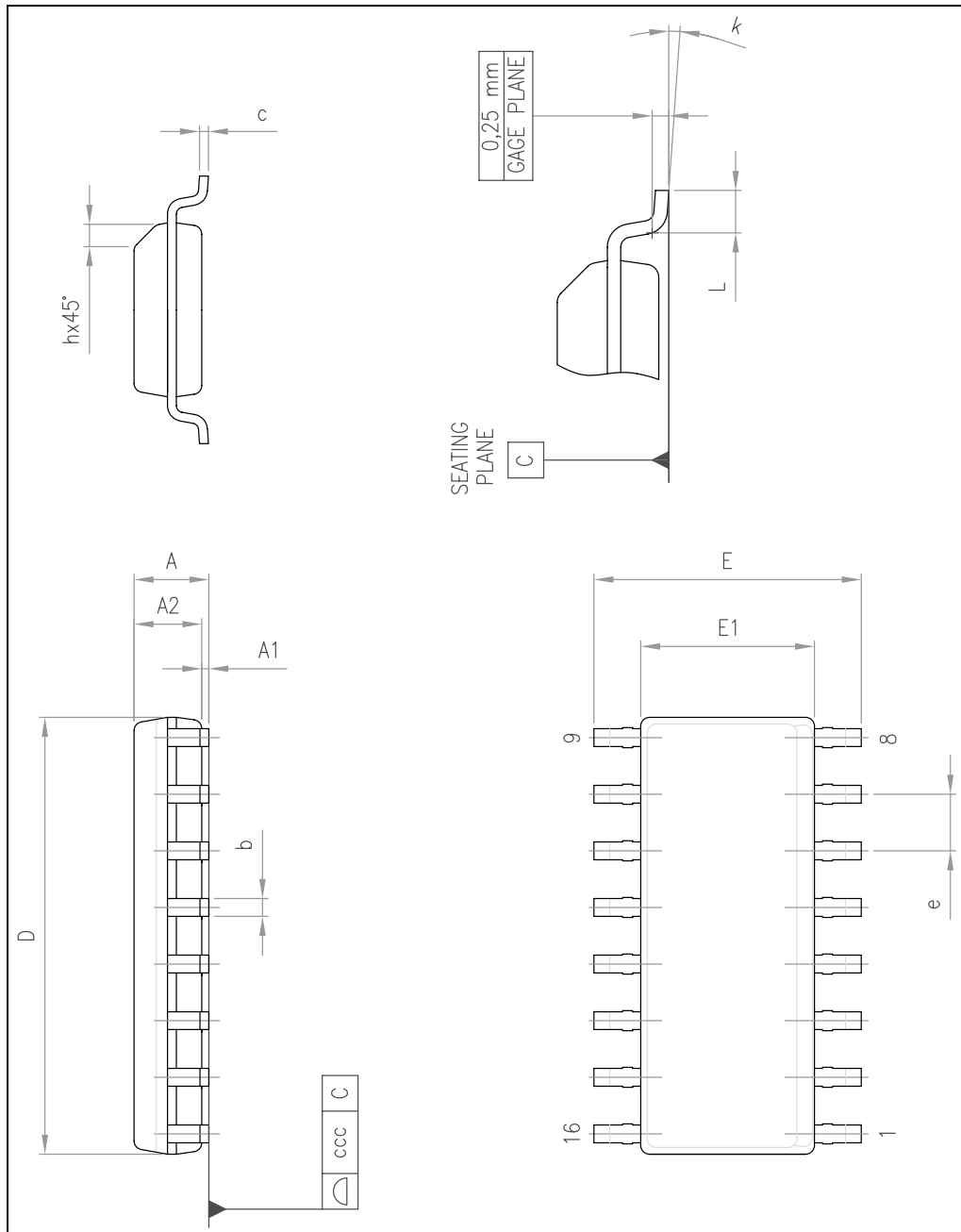

Table 10. SO16N mechanical data

Dim.	mm		
	Min	Typ	Max
A			1.75
A1	0.1		0.25
A2	1.25		
b	0.31		0.51
c	0.17		0.25
D	9.8	9.9	10
E	5.8	6	6.2
E1	3.8	3.9	4
e		1.27	
h	0.25		0.5
L	0.4		1.27
k	0		8
ccc			0.1

Figure 30. SO16N package dimensions



17 Revision history

Table 11. Document revision history

Date	Revision	Changes
26-Aug-2010	1	Initial release.
01-Sep-2010	2	Updated Figure 30 on page 23 .

Please Read Carefully:

Information in this document is provided solely in connection with ST products. STMicroelectronics NV and its subsidiaries ("ST") reserve the right to make changes, corrections, modifications or improvements, to this document, and the products and services described herein at any time, without notice.

All ST products are sold pursuant to ST's terms and conditions of sale.

Purchasers are solely responsible for the choice, selection and use of the ST products and services described herein, and ST assumes no liability whatsoever relating to the choice, selection or use of the ST products and services described herein.

No license, express or implied, by estoppel or otherwise, to any intellectual property rights is granted under this document. If any part of this document refers to any third party products or services it shall not be deemed a license grant by ST for the use of such third party products or services, or any intellectual property contained therein or considered as a warranty covering the use in any manner whatsoever of such third party products or services or any intellectual property contained therein.

UNLESS OTHERWISE SET FORTH IN ST'S TERMS AND CONDITIONS OF SALE ST DISCLAIMS ANY EXPRESS OR IMPLIED WARRANTY WITH RESPECT TO THE USE AND/OR SALE OF ST PRODUCTS INCLUDING WITHOUT LIMITATION IMPLIED WARRANTIES OF MERCHANTABILITY, FITNESS FOR A PARTICULAR PURPOSE (AND THEIR EQUIVALENTS UNDER THE LAWS OF ANY JURISDICTION), OR INFRINGEMENT OF ANY PATENT, COPYRIGHT OR OTHER INTELLECTUAL PROPERTY RIGHT.

UNLESS EXPRESSLY APPROVED IN WRITING BY AN AUTHORIZED ST REPRESENTATIVE, ST PRODUCTS ARE NOT RECOMMENDED, AUTHORIZED OR WARRANTED FOR USE IN MILITARY, AIR CRAFT, SPACE, LIFE SAVING, OR LIFE SUSTAINING APPLICATIONS, NOR IN PRODUCTS OR SYSTEMS WHERE FAILURE OR MALFUNCTION MAY RESULT IN PERSONAL INJURY, DEATH, OR SEVERE PROPERTY OR ENVIRONMENTAL DAMAGE. ST PRODUCTS WHICH ARE NOT SPECIFIED AS "AUTOMOTIVE GRADE" MAY ONLY BE USED IN AUTOMOTIVE APPLICATIONS AT USER'S OWN RISK.

Resale of ST products with provisions different from the statements and/or technical features set forth in this document shall immediately void any warranty granted by ST for the ST product or service described herein and shall not create or extend in any manner whatsoever, any liability of ST.

ST and the ST logo are trademarks or registered trademarks of ST in various countries.

Information in this document supersedes and replaces all information previously supplied.

The ST logo is a registered trademark of STMicroelectronics. All other names are the property of their respective owners.

© 2010 STMicroelectronics - All rights reserved

STMicroelectronics group of companies

Australia - Belgium - Brazil - Canada - China - Czech Republic - Finland - France - Germany - Hong Kong - India - Israel - Italy - Japan - Malaysia - Malta - Morocco - Philippines - Singapore - Spain - Sweden - Switzerland - United Kingdom - United States of America

www.st.com

