

**VICOR CONFIDENTIAL**

THIS DOCUMENT AND THE DATA DISCLOSED HEREIN OR HEREWITH IS NOT TO BE REPRODUCED, USED, OR DISCLOSED IN WHOLE OR IN PART TO ANYONE WITHOUT PERMISSION OF VICOR CORP.

REV.	DESCRIPTION	DATE	APPROVED
6	RELEASED PER ECO #E910657 CFH	11/25/91	[Signature]

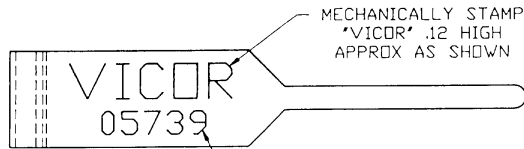
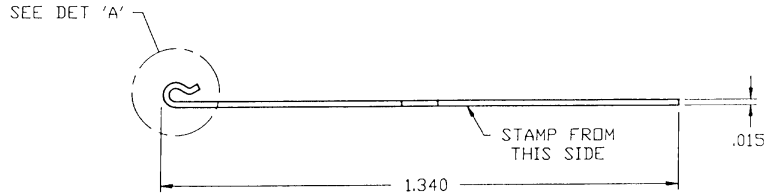
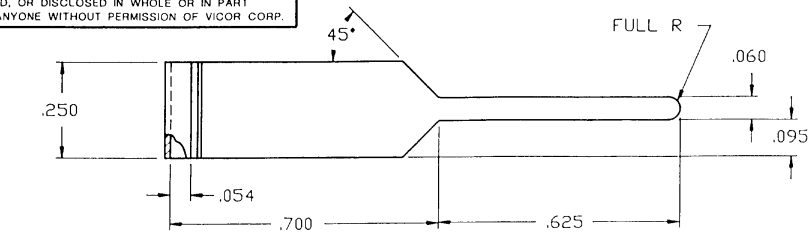

MECHANICALLY STAMP  
"05739" .06 HIGH  
APPROX AS SHOWN

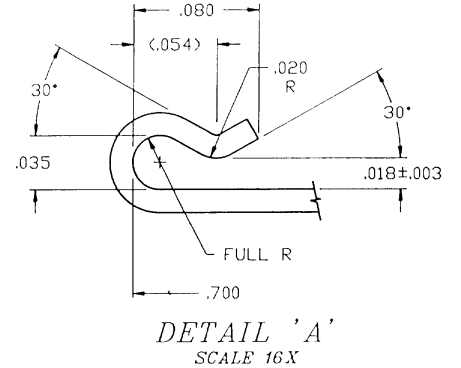

**NOTES**

1. MATERIAL: 260 BRASS .015 THK, HALF HARD.
2. FINISH: COPPER STRIKE AND SOLDER PLATE TO 100-300 μIN THICKNESS.

UNLESS OTHERWISE SPECIFIED DIMENSIONS ARE IN INCHES TOLERANCES ARE:

FRACTIONS DECIMALS ANGLES  
± 1/64 XX ± .01 ± 1'0  
XXX ± .005

THIRD ANGLE PROJECTION

DO NOT SCALE DRAWING

APPROVALS		DATE
DRAWN	C HUTCHINS	4/91
CHECKED		
ISSUED		
APP'D		



**GROUNDING CLIP,  
MODULE**

SIZE	FSCM NO.	DWG. NO.	REV.
B	67131	05739	6
SCALE 4X		SHEET 1 OF 1	