

Helping Customers Innovate, Improve & Grow



### Features

- High Precision TCXO
- OCXO Replacement
- OCXO Temperature Performance
- Low power consumption
- Tight Tolerances
- Frequency range <sup>1</sup> of 6.4 - 26 MHz
- Standard Frequencies : 10, 12.8, 19.2, 20, 26 MHz
- up to 40MHz on request <sup>1</sup>

### Applications

- Base Station
- Test Equipment
- Femto Base Station
- Communication Equipment
- Digital Switching

### Performance Specifications

Frequency Stabilities <sup>1</sup> (Standard - 6.4 to 26 MHz)						
Parameter	Min	Typical	Max	Units	Condition	
vs. operating temperature range (referenced to +25°C)	-280		+280	ppb	-40 to +85°C	Options <sup>3</sup>
	-140		+140	ppb	-40 to +85°C	
	-100		+100	ppb	-40 to + 85°C for some frequencies <sup>1</sup>	
	-100		-100	ppb	-20 to +70°C	
	-70		+70	ppb	-20 to +70°C	
	-50		+50	ppb	-20 to + 70°C for some frequencies <sup>1</sup>	
Initial tolerance	-0.5		+0.5	ppm	at time of shipment, nominal EFC	
vs. supply voltage change	-10		+10	ppb	V <sub>s</sub> ±5% static	
vs. load change	-10		+10	ppb	Load ±5% static	
vs. aging / day	-10		+10	ppb	after 30 days of operation	
vs. aging / year	-1.0		+1.0	ppm	after 30 days of operation	
vs. aging / 10 years	-3.0		+3.0	ppm	after 30 days of operation	

## Performance Specifications

Supply Voltage (Vs)						
Parameter	Min	Typical	Max	Units	Condition	
Supply voltage (standard)	3.135	3.3	3.465	VDC	@HCMOS	
Current consumption			12	mA		
RF Output						
Signal [standard]	HCMOS					
Load	13.5	15	16.5	pF		
Signal Level (Vol)			0.3	VDC	with Vs=3.3V and 15pF Load	
Signal Level (Voh)	2.6				with Vs=3.3V and 15pF Load	
Duty Cycle	40		60	%	@ (Voh-Vol)/2	
Rise and Fall time			5	ns	@15 pF 10 to 90 %	
Frequency Tuning (EFC) 6.4 to 26 MHz						
Tuning Range	Fixed TCXO; No adjust				Opti- on <sup>5</sup>	
Tuning Range	±5.0			ppm		
Linearity	<10%					
Tuning Slope	Positive					
Control Input Impedance	80	100	120	kOhm		
Control Voltage Range	0.3	1.65	3.0	VDC	with Vs=3.3V	
Additional Parameters						
Phase Noise <sup>2</sup>		-90		dBc/Hz	10 Hz	@ 12.8 MHz HCMOS 3.3 V
		-117		dBc/Hz	100 Hz	
		-137		dBc/Hz	1 kHz	
		-148		dBc/Hz	10 kHz	
		-151		dBc/Hz	100 kHz	
		-152		dBc/Hz	1 MHz	
Jitter		0.2		ps RMS	@ 12 kHz to 20 MHz	
Weight			8.0	g		
Processing & Packing	Handling & Processing Note					
Absolute Maximum Ratings						
supply voltage (Vs)			6.0	V	with Vs=3.3 VDC	
Output Load			50	pF		
Operable Temperature Range	-40		+85	°C		
Storage Temperature Range	-40		+90	°C		

# Outline Drawing / Enclosure

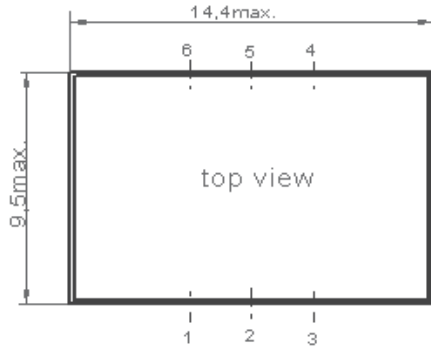

## G 287

H = 9,9 : G 287 A  
 H = 5,9 : G 287 B  
 H = 6,4 : G 287 C

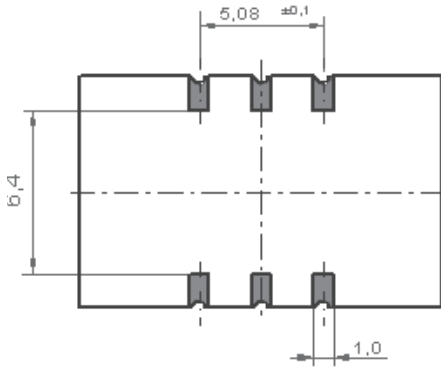
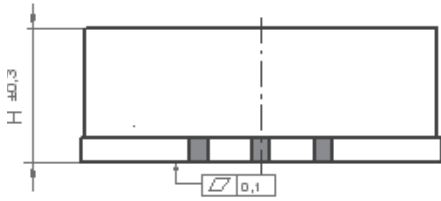

Dimensions in mm

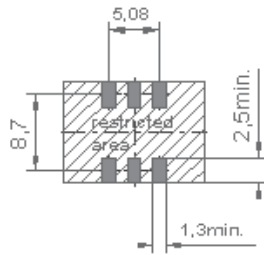

Padvorschlag  
 land pattern  
 recommendation

## TX-502

Height "H"	Pin Length "L"
5.9	NA

## Pin Connections

1	Control Voltage Input (Vc) / N.C.
2	N.C.
3	Ground (Case)
4	RF-Output
5	N.C.
6	Supply Voltage Input (Vs)

# Standard Shipping Method (TX-502)

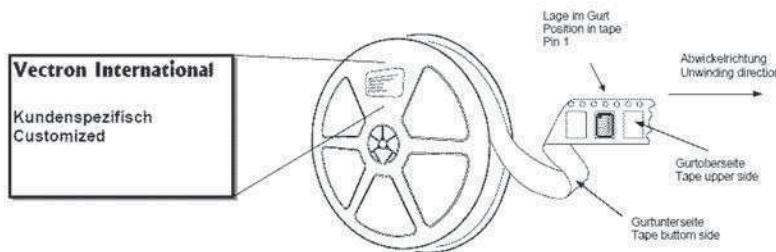
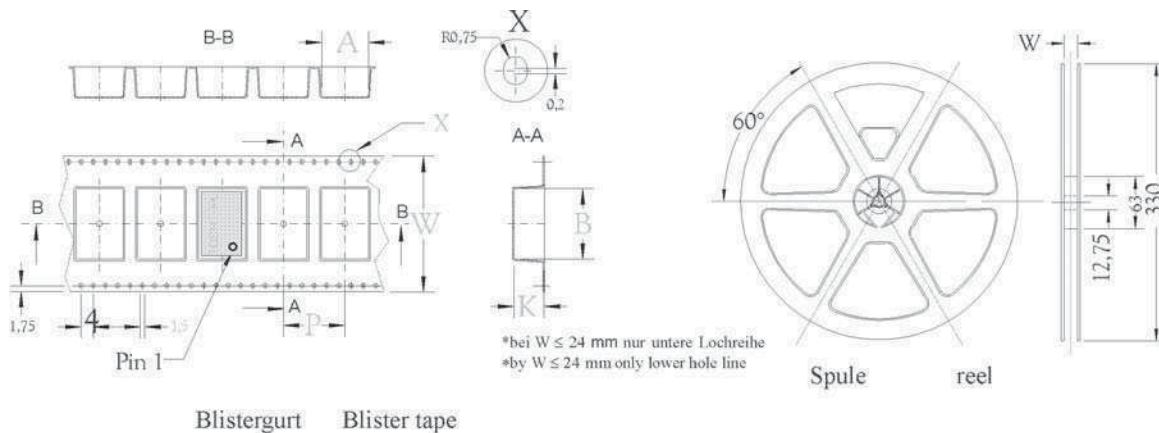

Enclosure Type	Tape Width W (mm)	Quantity per meter	Quantity per reel	Dimension P
G287	24	83,3	850	12

## Recommended Reflow Profile

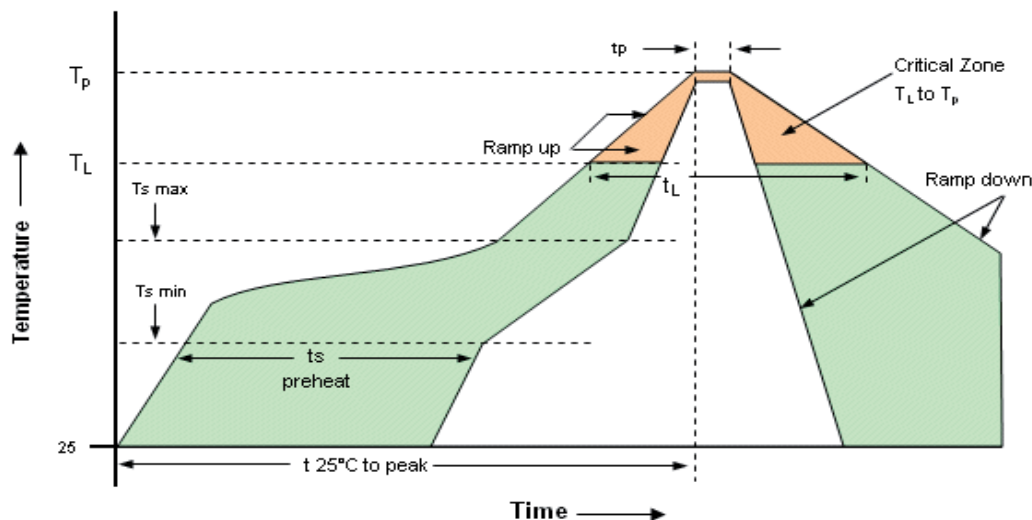

Profile Feature	Pb-Free Assembly/ Sn-Pb Assembly	Profile Feature	Pb-Free Assembly/ Sn-Pb Assembly
Average ramp-up rate ( $T_L$ to $T_p$ )	3°C/second max.	Time 25°C to Peak Temperature	8 minutes max.
Preheat -Temperature Min $T_{smin}$ -Temperature Min $T_{smax}$ -Time (min to max) $t_s$	150°C 200°C 60-180 seconds	Time maintained above -Temperature ( $T_L$ ) -Time ( $t_l$ )	217°C 60-150 seconds
$T_{smax}$ to $T_L$ -Ramp-up Rate	3°C/second max		
Time maintained above -Temperature ( $T_L$ ) -Time ( $t_l$ )	217°C 60-150 seconds	Time within 5°C of actual Peak Temperature ( $t_p$ )	20-40 seconds
Peak Temperature ( $T_p$ )	max 260°C	Ramp-down Rate	6°C/ second max

**Note:** All temperatures refer to topside of the package, measured on the package body surface.

## Ordering Information

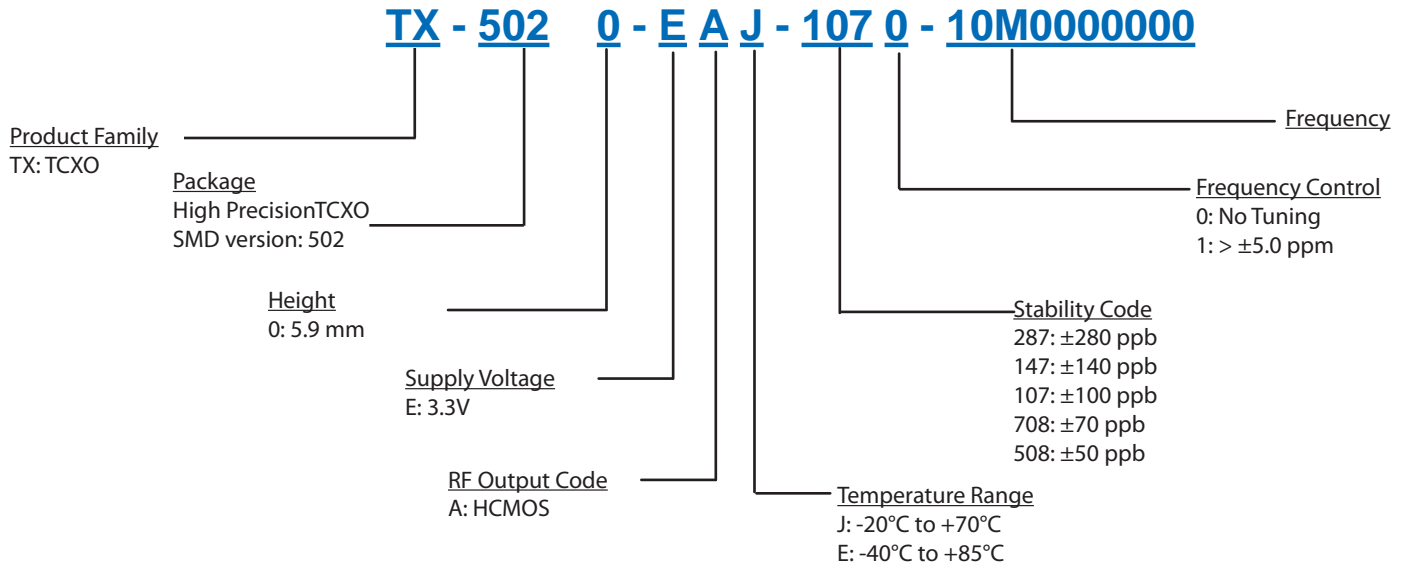

**Notes:**

1. Contact factory for improved stabilities or additional product options. Not all options and codes are available at all frequencies.
2. Phase noise degrades with increasing output frequency.
3. Contact factory for availability.

Unless other stated all values are valid at typical conditions for supply voltage, frequency control voltage, load, temperature (25°C).

Subject to technical modification.

## For Additional Information, Please Contact

**USA:**

Vectron International  
267 Lowell Road  
Hudson, NH 03051  
Tel: 1.888.328.7661  
Fax: 1.888.329.8328

**Europe:**

Vectron International  
Landstrasse, D-74924  
Neckarbischofsheim, Germany  
Tel: +49 (0) 7268.801.100  
Fax: +49 (0) 7268.801.282

**Asia:**

Vectron International  
1589 Century Avenue, the 19th Floor  
Chamtime International Financial Center  
Shanghai, China  
Tel: 86.21.6081.2888  
Fax: 86.21.6163.3598

**Disclaimer**

Vectron International reserves the right to make changes to the product(s) and or information contained herein without notice. No liability is assumed as a result of their use or application. No rights under any patent accompany the sale of any such product(s) or information.

Rev: 11/2010