

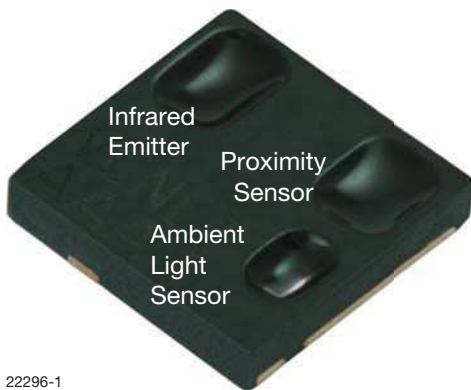

VCNL4000 Demo Kit

INTRODUCTION

The VCNL4000 is a proximity sensor with an integrated ambient light sensor. It is the industry's first optical sensor to combine an infrared emitter, PIN photodiode, ambient light sensor and signal processing IC in a single package with a 16-bit ADC for proximity measurement as well as ambient light measurement. The device provides ambient light sensing to support conventional backlight and display brightness adjustment, and proximity sensing for object and motion detection. With a range of up to 20 cm (7.9"), this stand-alone, single component greatly simplifies the use and design-in of a proximity sensor in consumer and industrial applications. The VCNL4000 features a miniature leadless package (LLP) for surface mounting in a 3.95 mm x 3.95 mm package with a low profile of 0.75 mm designed specifically for the low height requirements of smart phone, mobile phone, digital camera, and tablet PC applications. Through its standard I²C bus serial digital interface, it allows easy access to a "proximity signal" and "light intensity" measurement without complex calculations or programming. For complete details on the VCNL4000 please read "Designing VCNL4000 into an Application" at www.vishay.com/doc?83372.



22296-1

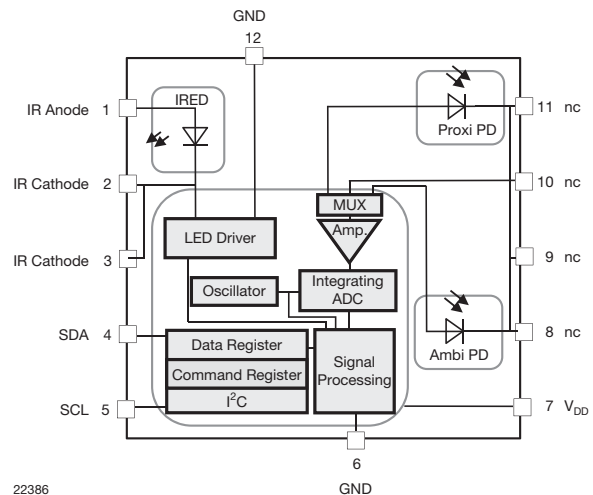

ESD WARNING

The VCNL4000 is sensitive to electrostatic discharge. Please take necessary precautions when handling the sensor and kit. For further information please read "Assembly Instructions" (www.vishay.com/doc?80080) and "Packaging and Ordering" (www.vishay.com/doc?80090).

ORDERING INFORMATION	
ORDERING CODE	VOLUME
VCNL4000demokit	MOQ: 1

APPLICATION NOTE

VCNL4000 Demo Kit

KIT COMPONENTS

There are three main components to the kit. The first is the blue sensor board on which is soldered the VCNL4000, a decoupling capacitor, and a 2 x 8 pin connector; the USB connector which supplies “clean” power to the sensor board; and the development software found on the CD. The sensor board can be plugged into the USB in the up or down orientation. An indicator light will be illuminated when the sensor board is receiving power and connected to the development software. The CD also contains a Quick Start menu and a software licensing agreement. Note that the licensing agreement must be saved in the C-drive before the software will run.

VCNL4000 Development Software

After installing the software, run the following command: `USB_Sensor_Kit_VCNL4000.exe`. When executing the program, the Proximity Function screen is displayed. There are four tabbed files: Proximity Function, Ambient Light Function, Register Values and Information VCNL4000.

PROXIMITY FUNCTION

Proximity Mode

Select a single measurement or periodic measurement. The periodic measurement rates are set in the Measurement Speed window. The default setting is “single measurement (on demand)”. Selecting periodic measurement sets the “prox_od” bit 3 of the command register #0 (80h) to “1”. Compensation offset and IIR filtering are only available with periodic measurements. See screen shot 1.

Measurement Parameter

Sets the infrared emitter current. The infrared emitter current determines the effective range of the sensor; higher current will translate to a longer sensing range. This feature can also be used to determine the impact of the cover or window on the sensing range. To compensate for the infrared light absorbed by the window, the current can be increased. The current can be set by either toggling up or down or by left clicking in the window and a current select bar will pop-up. The default setting is 100 mA.

Measurement Speed

Sets the delay time between two consecutive measurements when in periodic measurement mode. A delay time of “100” leads to about 10 measurements/s. Choosing “1” leads to more than 200 measurements/s which is fastest for this demo tool.

Clear Display

Clears the upper and lower window graphs and resets the “Data#” to zero. The Proximity Value field near the bottom of the screen is not cleared. This field will be updated with the next measurement.

Proximity Value

Changes the unit of measure for the proximity value. Click on the small blue letter on its left side. This letter indicates the selected format: b = binary, d = decimal, x = hexadecimal, o = octal, and p stands for SI notation

Infinite Impulse Response (IIR) Filter

This low pass filter is activated with the “active” button and shows an average of the measurement results. The average value can be changed from 1 to 20 by clicking on the toggle arrow where 1 corresponds to no averaging and 20 to strong averaging. When active, the button will be red.

Upper Window

Displays the entire 16-bit measured signal from 0 to 65535 counts.

Lower Window

Displays only the active or dynamic range. The y-axis represents the number of counts and will change depending on the sensor reading.

Proximity Measurement

Click on the Measure button to initiate a measurement.

Offset

Without an object in range, the upper window shows an offset of approximately 3000 counts. The lower window shows the exact values. This offset is a result of optical crosstalk and digital noise. In an application where a window is placed over the top of the sensor, the offset value can be as high as 10K to 15K counts. For the kit, the offset value is calculated by averaging the last 2 seconds of counts. In a smart phone application, for example, the offset value should be subtracted from incoming proximity readings and the resultant used to determine object proximity.

Object with Range of 200 mm and 100 mm

Assuming the offset value is 3070 counts, at a range of 200 mm, the reflection from a hand results in an output count of 3090 counts. This is 20 counts higher than the offset or noise floor. At a range of 100 mm, the reflection of the object results in an output count of 3130 counts. This is 50 counts higher than the offset or noise floor. By clicking the “Compensate Offset” button the software simulates this subtraction. When this function is active, the button will be red. With compensation offset active, the digital signal in the lower frame will display only the counts related to the reflected signal.



VCNL4000 Demo Kit

Object with Range of 10 mm and 5 mm

With compensation offset active, at a range of 10 mm, the reflection of the object results in an output count of approximately 1000 counts. At a range of 5 mm, the reflection of the object results in an output count of approximately 3000 counts. Again, with compensation offset active, the digital signal in the lower frame shows only the counts related to the reflected signal.

Display Range

Display a specific range of readings by entering a minimum reading number on the right side of the x-axis and the maximum reading number on the left side of the x-axis. Type over the existing displayed value. This feature is only available when measurements have stopped.

Register Values

The actual proximity value is available by selecting the Register Value tab. The high 16-bit value is stored in register #7 and the low value is stored in register #8. Register #7 equals 36° [00100100] and register #8 equals 33° [00100001]. See screen shot 2.

FORMAT FEATURES - PROXIMITY

Copy Graph

Right click within the upper or lower window and select “Copy Data”.

Change Line Color

Click inside the small white rectangle located between the upper and lower signal window to change line colors, patterns and other features.

AMBIENT LIGHT FUNCTION

Ambient Mode

Select a single measurement or periodic measurement. The default setting is “single measurement (on demand)”. Click Measure to execute the measure function. See screen shot 3.

Upper Window

Displays the entire 16 bit measured signal from 0 to 65 535 counts.

Lower Window

Displays only the active or dynamic range. The y-axis represents the number of counts and will change depending on the sensor reading.

Measurement Parameter

Defines the number of measurements used in the averaging function. Use the toggle button located under the “Sampled Values in 100 ms” title to scroll through available settings or click within the white value box and a pull down menu opens

displaying all available values. The advantage of this function is that disturbance from 50 Hz/60 Hz sources (100 Hz/120 Hz) is significantly reduced. The default setting is 128 which sets bit 0 to 2 of register #4 to 7° (111); translated, 2⁷ or 128 measurements within 100 ms. This averaged result is then available within Ambient Light Result register #5 and #6.

Auto Offset

Compensates for temperature related drift of the ambient light measurements. With auto offset active, the offset value is measured before each ambient light measurement and subtracted automatically from the actual reading. The default setting is “Auto Offset” active. “Auto Offset” is bit 3 of Ambient Light Parameter Register #4 (84h).

Continuous Conversion

Allows for faster measurements. With this selected single conversions are made in a much shorter time.

Clear Display

Clears the upper and lower window graphs and resets the “Data#” to zero. The Ambient Light Value field near the bottom of the screen is not cleared. This field will be updated with the next measurement.

Ambient Light Value

Displays the ambient light value in binary form only.

Illuminance

Displays the ambient light level in lux. It is calculated by dividing the number of counts by four. For example, there are 615 counts which, when divided by four, results in 153.75.

Figure of Merit

The ideal ambient light sensor will produce exactly the same output (counts) for the same brightness regardless of the source of light. In reality, silicon-based ambient light sensors will produce slightly different readings for halogen (2856K CIE illuminant A), incandescent, fluorescent and white LED sources. Figure 2 shows the average response for the VCNL4000 ambient light sensor for all the above light sources and graphs the number of counts versus lux value for each light source. The halogen lamp shows a factor of 5.1 for digital counts versus lux, the fluorescent lamp shows a factor of 3.2 and white LEDs shows a factor of 4.1. The average response is a factor of 4 counts per lux. As shown in fig. 1, a count of 1000 corresponds to 250 lx. This same count could be 200 lx for the halogen lamp or 310 lx for the fluorescent lamp. The overall tolerance for the VCNL4000 ambient light sensor for different light sources is - 22 % to + 24 %.

VCNL4000 Demo Kit

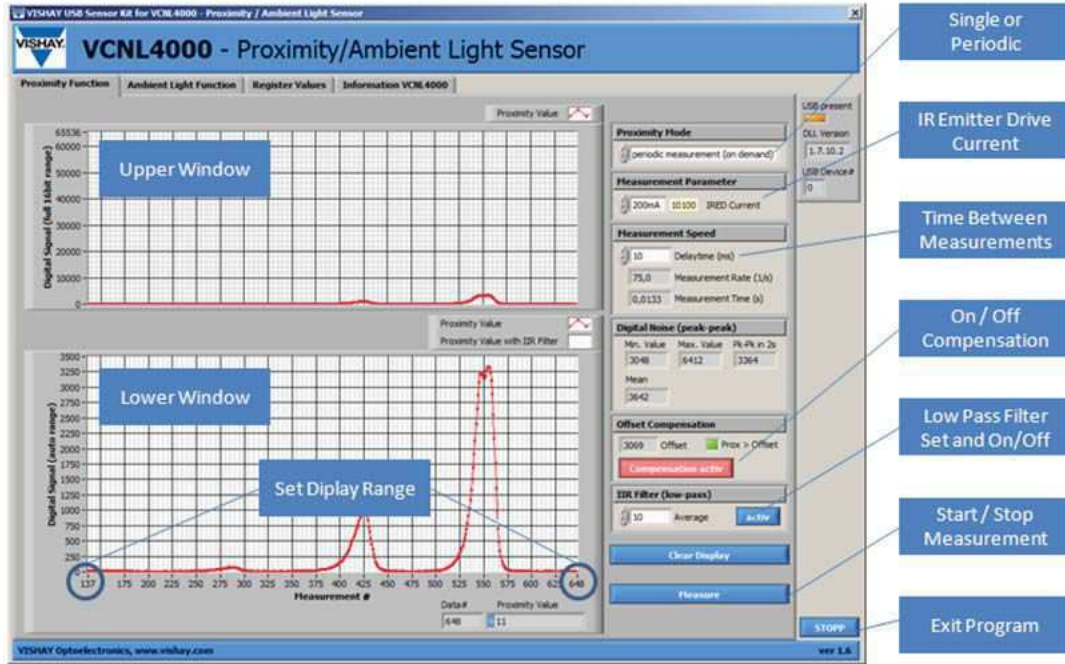

Screen Shot 1

The screenshot shows the 'Register Functions and Values' table in the software. The table lists various registers with their addresses and values in decimal and hexadecimal. A 'New Register Values' section is also visible on the right side of the table.

Register #	Register Value (dec)	Register Value (hex)	New Register Values Register Value (dec)
0	128	10000000	
1	17	00010001	
2	0	00000000	
3	10	00001010	
4	29	00011101	
5	0	00000000	read only
6	0	00000000	read only
7	36	00100100	read only
8	33	00100001	read only
9	3	00000011	
10	129	10000001	
11	1	00000001	
12	0	00000000	not for customer use
13	0	00000000	not for customer use
14	0	00000000	not for customer use
15	0	00000000	not for customer use
16	0	00000000	not for customer use
17	0	00000000	not for customer use
18	0	00000000	not for customer use
19	64	01000000	not for customer use
20	0	00000000	not for customer use
21	26	00011010	not for customer use
22	8	00001000	not for customer use
23	22	00010110	not for customer use
24	3	00000011	not for customer use
25	98	01100010	not for customer use
26	28	00011000	not for customer use
27	152	10011000	not for customer use
28	21	00010101	not for customer use
29	26	00011010	not for customer use
30	1	00000001	not for customer use

Screen Shot 2

VCNL4000 Demo Kit

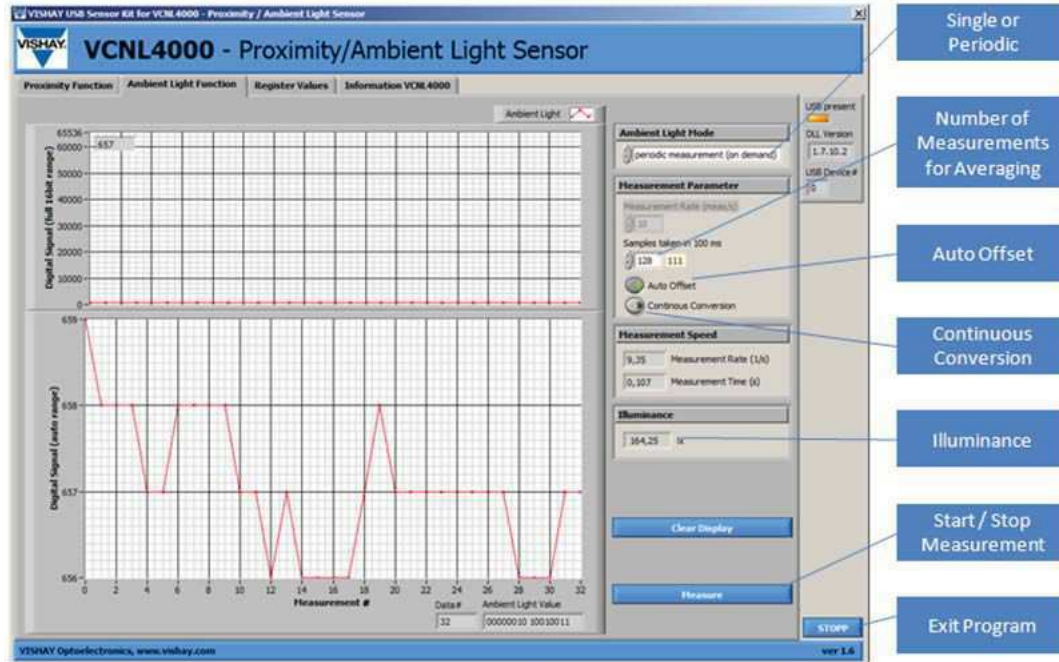

Screen Shot 3

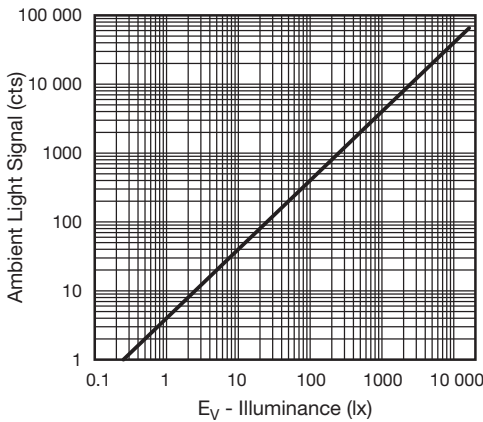

Fig. 1

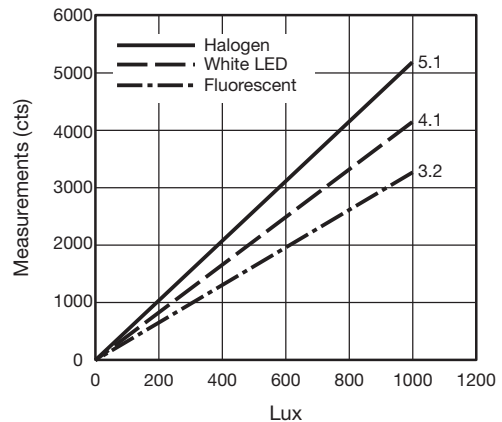

Fig. 2

VCNL4000 Demo Kit

SCHEMATIC

Board Layout

The sensor board includes the VCNL4000 sensor and a 470 nF capacitor. It is connected to the common 3.3 V power supply used for the infrared emitter on pin1 and the ASIC_VDD on pin 7. As is shown in fig.1, large areas of the top side are ground plane to avoid ESD problems when handling the board. The odd-numbered pins are on top side and the even-numbered on the bottom side.

Schematic

Only 4 wires are needed to connect to VCNL4000: SDA (J1) and SCL (J3) need to be connected to Microcontroller; VCC (J11) needs to be connected to the Power supply; and Ground pin (J2/J15) needs to be connected to the application ground plane. Figure 2.

Useful Links

I²C specification Version 2.1:

www.nxp.com/acrobat_download2/literature/9398/39340011.pdf

I²C specification Version 3.0:

www.nxp.com/documents/user_manual/UM10204.pdf

Male pin connector 2199SB-XXG-301523 :

www.almita.com.tw/pro25.htm

Female pin connector 2200SG-XG-A1



VCNL4000 Sensor Board

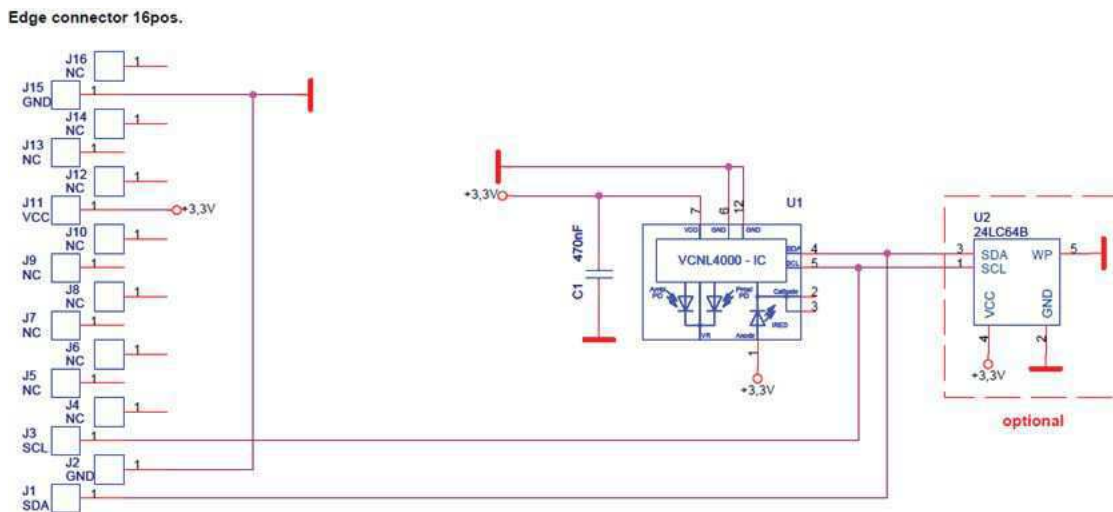

Circuit Diagram of VCNL4000 Sensor Board