



PN2222A

NPN SILICON TRANSISTOR

NPN GENERAL PURPOSE AMPLIFIER

■ FEATURES

* This device is for use as a medium power amplifier and switch requiring collector currents up to 500mA.

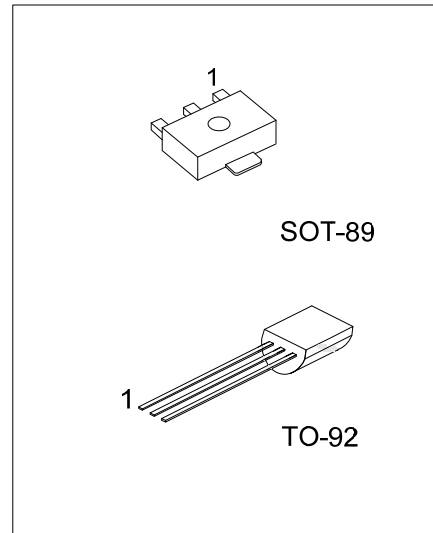

■ ORDERING INFORMATION

Ordering Number			Package	Pin Assignment			Packing
Normal	Lead Free Plating	Halogen Free		1	2	3	
PN2222A-AB3-R	PN2222AL-AB3-R	PN2222AG-AB3-R	SOT-89	B	C	E	Tape Reel
PN2222A-T92-B	PN2222AL-T92-B	PN2222AG-T92-B	TO-92	E	B	C	Tape Box
PN2222A-T92-K	PN2222AL-T92-K	PN2222AG-T92-K	TO-92	E	B	C	Bulk

<p>PN2222AL-AB3-R</p> <p>(1)Packing Type</p> <p>(2)Package Type</p> <p>(3)Lead Plating</p>	<p>(1) B: Tape Box, K: Bulk, R: Tape Reel</p> <p>(2) AB3: SOT-89, T92: TO-92</p> <p>(3) G: Halogen Free, L: Lead Free Plating, Blank: Pb/Sn</p>
--	---

■ ABSOLUTE MAXIMUM RATING ($T_A=25^\circ\text{C}$, unless otherwise specified)

PARAMETER		SYMBOL	RATINGS	UNIT
Collector-Base Voltage		V_{CB0}	75	V
Collector-Emitter Voltage		V_{CEO}	40	V
Emitter-Base Voltage		V_{EBO}	6	V
Collector Current		I_C	0.6	A
Total Device Dissipation	SOT-89	P_C	1.2	W
	TO-92		0.6	
Junction Temperature		T_J	+150	$^\circ\text{C}$
Storage Temperature		T_{STG}	-55 ~ +150	$^\circ\text{C}$

Note: Absolute maximum ratings are those values beyond which the device could be permanently damaged. Absolute maximum ratings are stress ratings only and functional device operation is not implied.

■ THERMAL DATA ($T_A=25^\circ\text{C}$, unless otherwise noted)

PARAMETER		SYMBOL	RATINGS	UNIT
Junction to Ambient	SOT-89	θ_{JA}	104	$^\circ\text{C/W}$
	TO-92		200	

■ ELECTRICAL CHARACTERISTICS ($T_A=25^\circ\text{C}$, unless otherwise specified)

PARAMETER	SYMBOL	TEST CONDITIONS	MIN	TYP	MAX	UNIT
OFF CHARACTERISTICS						
Collector-Base Breakdown Voltage	BV_{CB0}	$I_C=10\mu\text{A}$, $I_E=0$	75			V
Collector-Emitter Breakdown Voltage	BV_{CEO}	$I_C=10\text{mA}$, $I_B=0$	40			V
Emitter-Base Breakdown Voltage	BV_{EBO}	$I_E=10\mu\text{A}$, $I_C=0$	6			V
Collector Cut-off Current	I_{CEO}	$V_{CE}=60\text{V}$, $V_{EB(OFF)}=3.0\text{V}$			10	nA
Collector Cut-Off Current	I_{CBO}	$V_{CB}=60\text{V}$, $I_E=0$			0.01	μA
Emitter Cut-Off Current	I_{EBO}	$V_{EB}=3.0\text{V}$, $I_C=0$			10	nA
Base Cut-Off Current	I_{BL}	$V_{CE}=60\text{V}$, $V_{EB(OFF)}=3.0\text{V}$			20	nA
ON CHARACTERISTICS						
DC Current Gain	h_{FE}	$I_C=0.1\text{mA}$, $V_{CE}=10\text{V}$	35			
		$I_C=1.0\text{mA}$, $V_{CE}=10\text{V}$	50			
		$I_C=10\text{mA}$, $V_{CE}=10\text{V}$	75			
		$I_C=150\text{mA}$, $V_{CE}=10\text{V}$ (Note)	100			
		$I_C=150\text{mA}$, $V_{CE}=1.0\text{V}$ (Note)	50		300	
		$I_C=500\text{mA}$, $V_{CE}=10\text{V}$ (Note)	40			
Collector-Emitter Saturation Voltage (Note)	$V_{CE(SAT)}$	$I_C=150\text{mA}$, $I_B=15\text{mA}$			0.3	V
		$I_C=500\text{mA}$, $I_B=50\text{mA}$			1.0	
Base-Emitter Saturation Voltage (Note)	$V_{BE(SAT)}$	$I_C=150\text{mA}$, $I_B=15\text{mA}$	0.6		1.2	V
		$I_C=500\text{mA}$, $I_B=50\text{mA}$			2.0	
SMALL SIGNAL CHARACTERISTICS						
Transition Frequency	f_T	$I_C=20\text{mA}$, $V_{CE}=20\text{V}$, $f=100\text{MHz}$	300			MHz
Output Capacitance	C_{ob0}	$V_{CB}=10\text{V}$, $I_E=0$, $f=100\text{kHz}$			8.0	pF
Input Capacitance	C_{ib0}	$V_{EB}=0.5\text{V}$, $I_C=0$, $f=100\text{kHz}$			25	pF
Collector Base Time Constant	$r_b'C_c$	$I_C=20\text{mA}$, $V_{CB}=20\text{V}$, $f=31.8\text{MHz}$			150	pS
Noise Figure	NF	$I_C=100\mu\text{A}$, $V_{CE}=10\text{V}$, $R_S=1.0\text{k}\Omega$, $f=1.0\text{kHz}$			4.0	dB
Real Part of Common-Emitter High Frequency Input Impedance	$\text{Re}(h_{ie})$	$I_C=20\text{mA}$, $V_{CB}=20\text{V}$, $f=300\text{MHz}$			60	Ω

■ ELECTRICAL CHARACTERISTICS ($T_A=25^\circ\text{C}$, unless otherwise specified)

PARAMETER	SYMBOL	TEST CONDITIONS	MIN	TYP	MAX	UNIT
SWITCHING CHARACTERISTICS						
Delay time	t_D	$V_{CC}=30\text{V}$, $V_{BE(OFF)}=0.5\text{V}$			10	ns
Rise time	t_R	$I_C=150\text{mA}$, $I_{B1}=15\text{mA}$			25	ns
Storage time	t_S	$V_{CC}=30\text{V}$, $I_C=150\text{mA}$			225	ns
Fall time	t_F	$I_{B1}=I_{B2}=15\text{mA}$			60	ns

Note: Pulse test: Pulse Width $\leq 300\mu\text{s}$, Duty Cycle $\leq 2.0\%$

■ TEST CIRCUIT

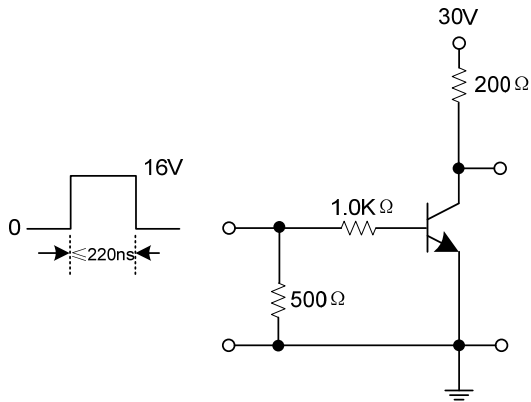

Saturated Turn-On Switching Time

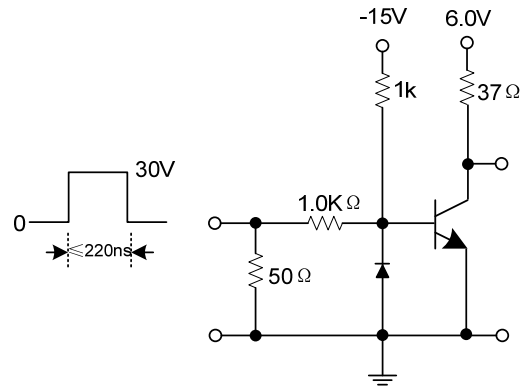

Saturated Turn-Off Switching Time

■ TYPICAL CHARACTERISTICS

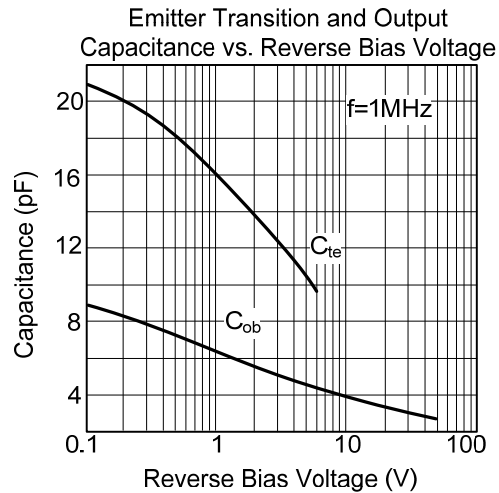
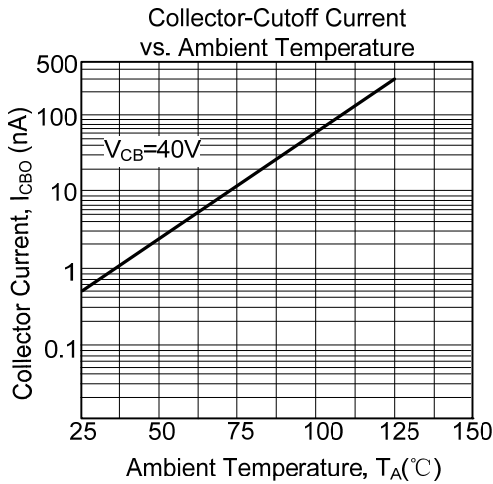
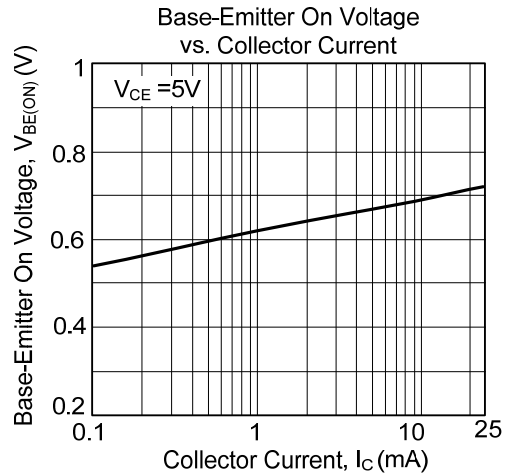
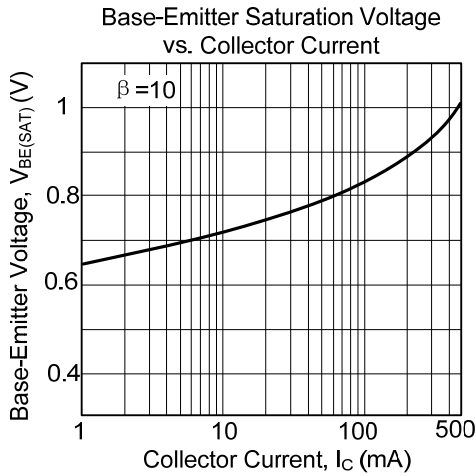
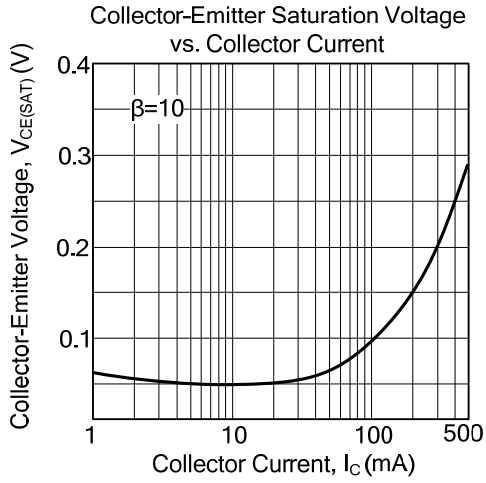
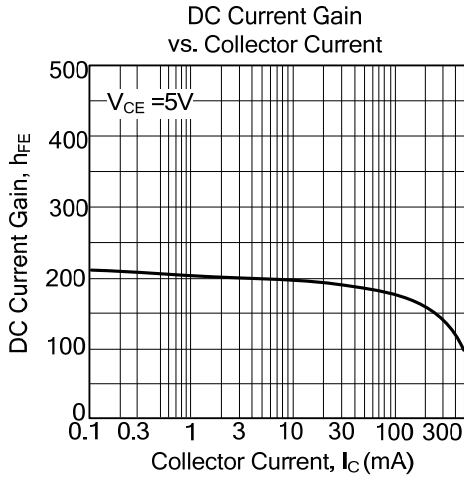

■ TYPICAL CHARACTERISTICS(Cont.)

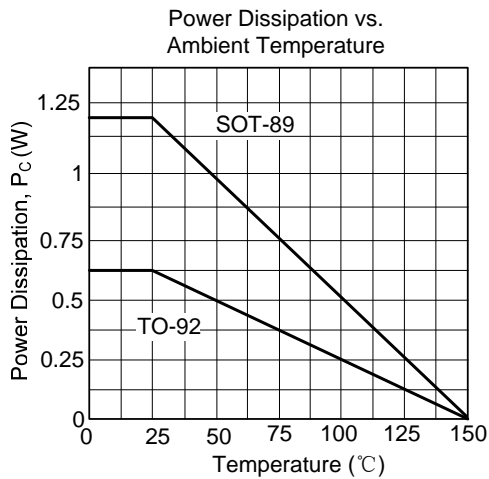
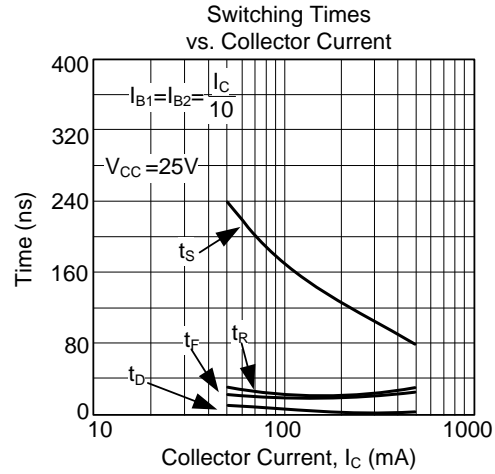
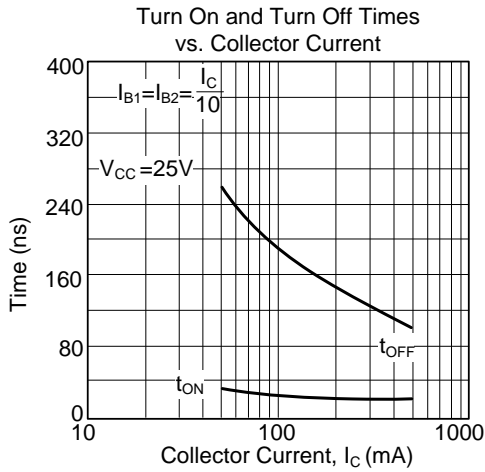

UTC assumes no responsibility for equipment failures that result from using products at values that exceed, even momentarily, rated values (such as maximum ratings, operating condition ranges, or other parameters) listed in products specifications of any and all UTC products described or contained herein. UTC products are not designed for use in life support appliances, devices or systems where malfunction of these products can be reasonably expected to result in personal injury. Reproduction in whole or in part is prohibited without the prior written consent of the copyright owner. The information presented in this document does not form part of any quotation or contract, is believed to be accurate and reliable and may be changed without notice.