

Radar Pulsed Power Transistor, 0.85W, 2ms Pulse, 20% Duty 1.2 - 1.4 GHz

PH1214-0.85L

V2.00

Features

- NPN Silicon Microwave Power Transistor
- Common Emitter Configuration
- Broadband Class A Operation
- Matrix Geometry
- Diffused Emitter Ballasting Resistors
- Gold Metalization System
- Internal Input Impedance Matching
- Hermetic Metal/Ceramic Package

Absolute Maximum Ratings at 25°C

Parameter	Symbol	Rating	Units
Collector-Emitter Voltage	V_{CES}	27	V
Collector-Emitter Voltage	V_{CEO}	20	V
Emitter-Base Voltage	V_{EBC}	3.5	V
Collector Current (Peak)	I_C	710	mA
Total Power Dissipation	P_{TOT}	7.8	W
Junction Temperature	T_J	200	°C
Storage Temperature	T_{STG}	-65 to +200	°C

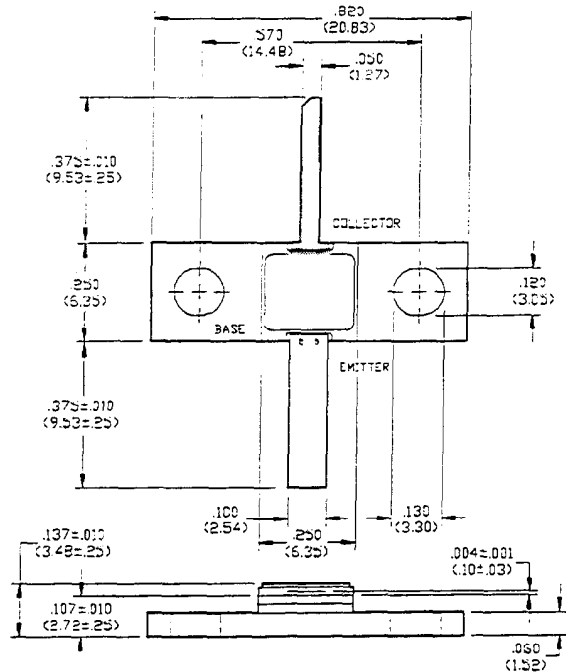

UNLESS OTHERWISE NOTED, TOLERANCES ARE INCHES = .005" (MILLIMETERS = .13MM)

Electrical Characteristics at 25°C

Parameter	Symbol	Min	Max	Units	Test Conditions
Collector-Emitter Breakdown Voltage	BV_{CES}	27	-	V	$I_C=4$ mA
Collector-Emitter Breakdown Voltage	BV_{CEO}	20	-	V	$I_C=10$ mA
Collector-Emitter Leakage Current	I_{CES}	-	1.0	mA	$V_{CE}=15$ V
DC Forward Current Gain	h_{FE}	60	250	-	$V_{CE}=5$ V, $I_C=100$ mA
Thermal Resistance	$R_{TH(JC)}$	-	19	°C/W	
Output Power	P_{OUT}	0.85	-	W	$V_{FIXT}=22$, $V_{CE}(typ)=11.5$, $I_{CO}(typ)=200$ mA $P_{IN}=100$ mW, $F=1.20, 1.30, 1.40$ GHz
Power Gain	G_P	9.3	-	dB	
Collector Efficiency	η_C	30	-	%	
Input Return Loss	RL	9	-	dB	
Load Mismatch Tolerance	VSWR-T	-	2:1	-	
Load Mismatch Stability	VSWR-S	-	1.5:1	-	

Broadband Test Fixture Impedances

F(GHz)	$Z_{IF}(\Omega)$	$Z_{OF}(\Omega)$
1.20	5.9 - j4.5	7.4 + j6.3
1.30	6.4 - j4.0	7.5 + j7.7
1.40	7.1 - j4.4	7.4 + j8.9

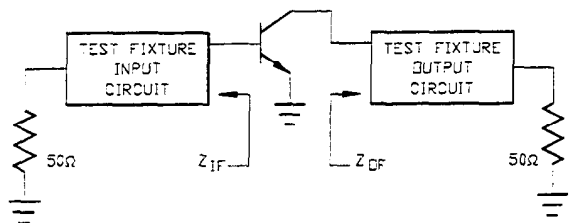

Specifications Subject to Change Without Notice.

9-112

M/A-COM, Inc.

North America: Tel. (800) 366-2266
Fax (800) 618-8883

Asia/Pacific: Tel. +81 (03) 3226-1671
Fax +81 (03) 3226-1451

Europe: Tel. +44 (1344) 869 595
Fax +44 (1344) 300 020

RF Test Fixture

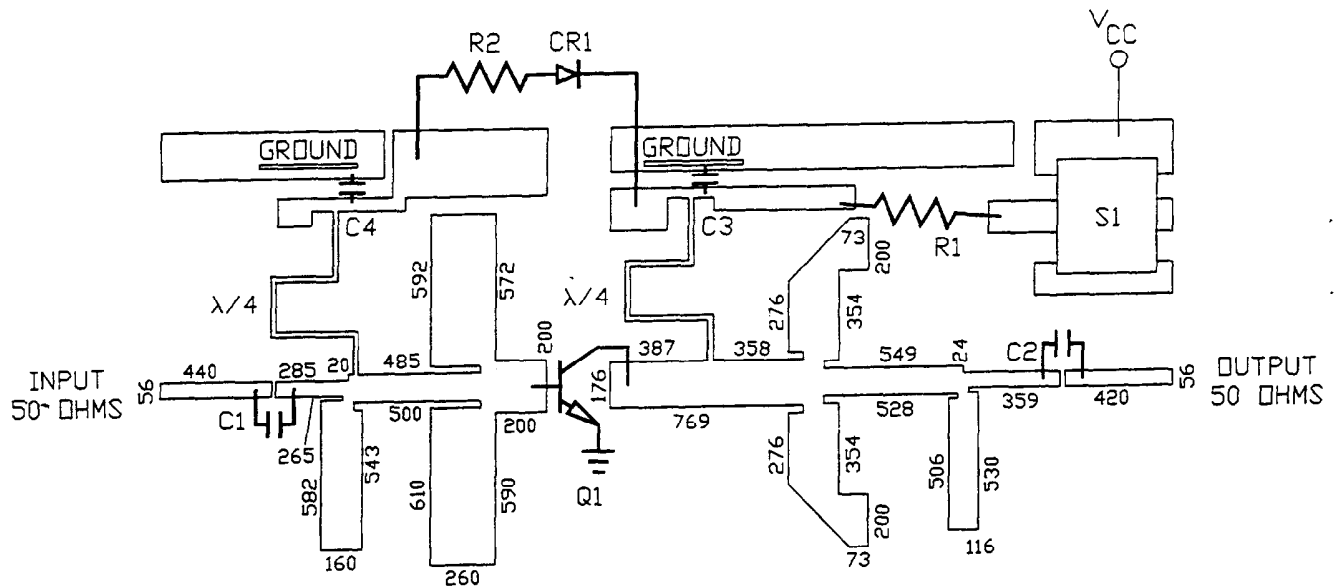

ARTWORK DIMENSIONS IN MILS

PARTS LIST

- C1 C2 100 pF ATC SIZE A
- C3 C4 .68 uF 35 VOLTS
- CR1 DIODE ECG5016A
- Q1 PH1214-.85L
- R1 52 OHMS 2 WATTS
- R2 830 OHMS 1/4 WATT
- S1 DPDT
- BOARD TYPE: ROGERS 6010.5 .025' THICK, $E_R = 10.5$

Specifications Subject to Change Without Notice.

MA-COM, Inc.

North America: Tel. (800) 366-2266
Fax (800) 618-8883

Asia/Pacific: Tel. +81 (03) 3226-1671
Fax +81 (03) 3226-1451

Europe: Tel. +44 (1344) 869 595
Fax +44 (1344) 300 020

9-113