

# AlGaAs SP8T PIN Diode Series Switch

## MA4AGSW8-1

### Features

- Specified Performance : 50 MHz to 40 GHz
- Operational performance: 50 MHz to 50 GHz
- 2.0 dB Typical Insertion Loss at 40 GHz
- 30 dB Typical Isolation at 40 GHz thru 3 Diodes
- 22 dB Typical Isolation at 40 GHz thru 2 Diodes
- Low Current consumption :
  - 10 mA for low loss state
  - 0 Volts for Isolation state
- M/A-COM's unique patent pending AlGaAs hetero-junction anode technology
- Silicon Nitride Passivation
- BCB Impact Protection

### Description

M/A-COM's MA4AGSW8-1 is an Aluminum-Gallium- Arsenide (AlGaAs) anode enhanced, SP8T PIN diode Series Switch. Operation is accomplished with 10 mA applied to the low loss port and 0 V for the isolated ports.

M/A-COM's AlGaAs process utilizes a patent pending hetero-junction technology which produces lower insertion loss than conventional GaAs devices. These devices are fabricated on an OMCVD epitaxial wafer using a process designed for high device uniformity and extremely low parasitics. The diodes exhibit low series resistance, (  $3 \Omega$  ), low capacitance ( 20 fF ), and fast switching speed ( 20 ns ).

The MA4AGSW8-1 device is fully passivated with silicon nitride, and has an additional layer of a polyamide for impact protection. This protective coating prevents damage to the junction and the anode air bridges during assembly and test. RF to DC bias networks are required. This allows the MA4AGSW8-1 device to be optimized for a particular operating band.

### Applications

The low capacitance of the PIN diodes makes this device ideal for use in microwave multi-throw switch designs. The low series resistance of the diodes reduces the insertion loss of the devices at microwave/millimeter-wave frequencies. These AlGaAs PIN switches are used as switching arrays on radar systems, optical switching networks, instrumentation, and other wideband multi-throw switch assemblies.

### MA4AGSW8-1 Layout

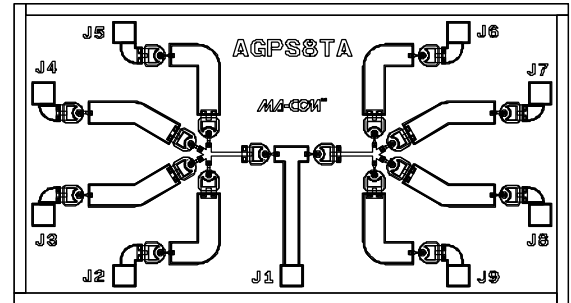

### Absolute Maximum Ratings<sup>1</sup>

@ TA = +25 °C (Unless otherwise specified)

Parameter	Maximum Rating
Operating Temperature	-55 °C to +1 25 °C
Storage Temperature	-65 °C to +1 50 °C
Incident C.W. RF Power	+ 23 dBm C. W.
Reverse Voltage	25 V
Bias Current	+/- 30 mA

1. Exceeding any of these values may result in permanent damage

## Electrical Specifications @ $T_A = 25\text{ }^\circ\text{C}$ , -15 mA Bias Current, and 0 Volts (On-Wafer Measurements)

RF Specifications					
Parameter	Frequency	Minimum	Typical	Maximum	Units
Insertion Loss	0.05 - 18 GHz	-	1.5	2.0	dB
	18 - 26 GHz	-	1.8	2.1	dB
	26 - 40 GHz	-	2.0	2.3	dB
Isolation <sup>1</sup>	0.05 - 18 GHz	30	32	-	dB
	18 - 26 GHz	30	32	-	dB
	26 - 40 GHz	30	32	-	dB
Input/Output Return Loss	0.05 - 18 GHz	10	15	-	dB
	18 - 26 GHz	13	15	-	dB
	26 - 40 GHz	10	20	-	dB
Switching Speed <sup>2</sup>	10 GHz	-	20	-	ns

### NOTES:

- Isolation is measured through (3) Diodes from Common Port ( Input ) to Selected Output Port with (1) Opposite Port in Low Loss. Isolation for (2) Diodes from Common Port ( Input ) to Selected Output with (1) Adjacent Port in Low Loss = 22 dB Typical.
- Typical switching speed is measured from 10% to 90% of the detected RF voltage driven by a +/- 5 V TTL compatible driver. Driver output parallel RC network uses a capacitor between 390 pF - 560 pF and a resistor between 150 - 220 Ohms to achieve 20 ns rise and fall times.

## Typical Driver Connections

Input Port	Output Ports							
	@J2	@J3	@J4	@J5	@J6	@J7	@J8	@J9
<b>J1</b>	<b>Low Loss</b>	Isolation	Isolation	Isolation	Isolation	Isolation	Isolation	Isolation
<b>J1</b>	Isolation	<b>Low Loss</b>	Isolation	Isolation	Isolation	Isolation	Isolation	Isolation
<b>J1</b>	Isolation	Isolation	<b>Low Loss</b>	Isolation	Isolation	Isolation	Isolation	Isolation
<b>J1</b>	Isolation	Isolation	Isolation	<b>Low Loss</b>	Isolation	Isolation	Isolation	Isolation
<b>J1</b>	Isolation	Isolation	Isolation	Isolation	<b>Low Loss</b>	Isolation	Isolation	Isolation
<b>J1</b>	Isolation	Isolation	Isolation	Isolation	Isolation	<b>Low Loss</b>	Isolation	Isolation
<b>J1</b>	Isolation	Isolation	Isolation	Isolation	Isolation	Isolation	<b>Low Loss</b>	Isolation
<b>J1</b>	Isolation	Isolation	Isolation	Isolation	Isolation	Isolation	Isolation	<b>Low Loss</b>

### NOTES:

- Low Loss** = -15mA applied at the specified Output Port. (A dc ground return at port J1 must be provided)
- Isolation** = 0 Volts applied at the specified Output Ports.

Microwave and Millimeter Wave Performance

Typical Insertion Loss

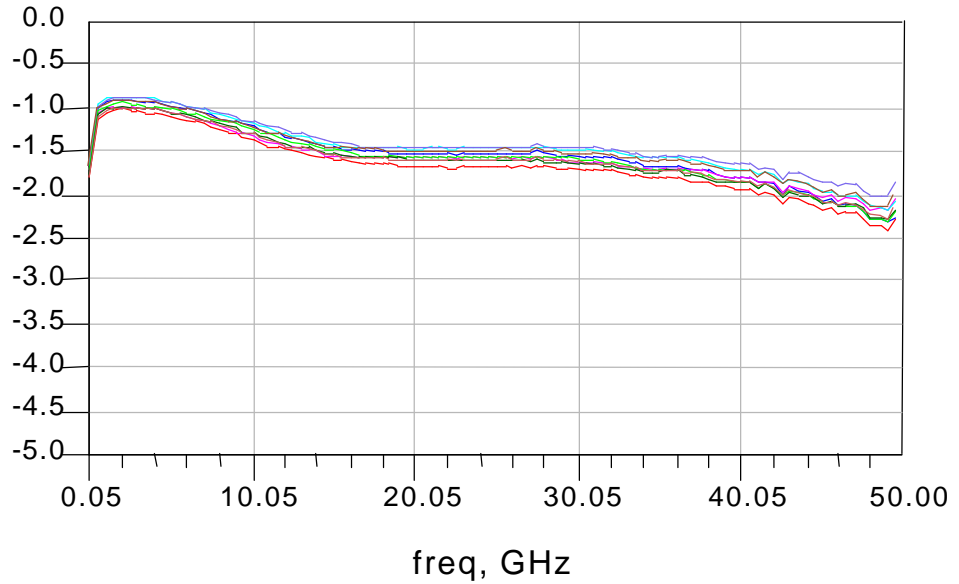

Typical Return Loss

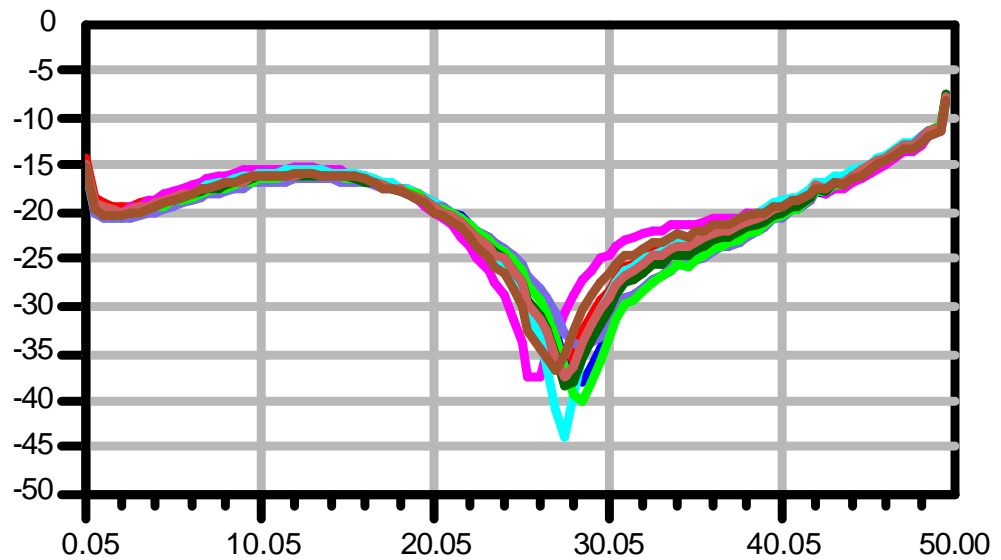

M/A-COM Inc. and its affiliates reserve the right to make changes to the product(s) or information contained herein without notice.

Visit [www.macom.com](http://www.macom.com) for additional data sheets and product information.

- North America: Tel. (800) 366-2266
- Asia/Pacific: Tel.+81-44-844-8296, Fax +81-44-844-8298
- Europe: Tel. +44 (1908) 574 200, Fax+44 (1908) 574 300



Microwave and Millimeter Wave Performance (cont'd)

Typical Isolation

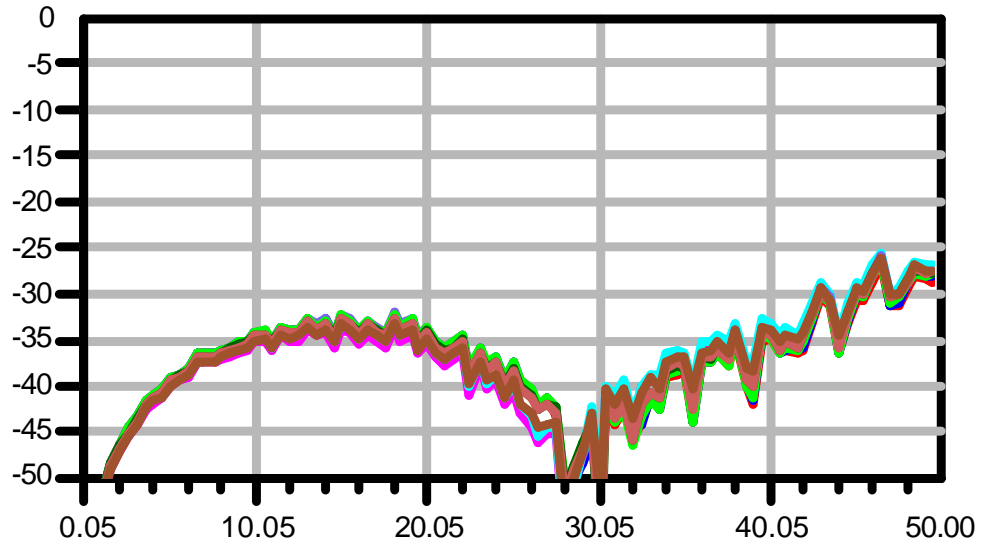

M/A-COM Inc. and its affiliates reserve the right to make changes to the product(s) or information contained herein without notice.

Visit [www.macom.com](http://www.macom.com) for additional data sheets and product information.

- North America: Tel. (800) 366-2266
- Asia/Pacific: Tel.+81-44-844-8296, Fax +81-44-844-8298
- Europe: Tel. +44 (1908) 574 200, Fax+44 (1908) 574 300



## Assembly Considerations

The following precautions should be observed to avoid damaging these chips.

## Cleanliness

These chips should be handled in a clean environment. Do not attempt to clean die after installation.

## Electro-Static Sensitivity

These Devices are considered ESD Class1. Proper ESD techniques should be used when handling these devices.

## General Handling

The protective polymer coating on the active areas of these die provides scratch and impact protection, particularly for the metal airbridge which contacts the diode's anode. Die should primarily be handled with vacuum pickups, or alternatively with plastic tweezers.

## Mounting Techniques

These AlGaAs devices are designed to be mounted with electrically conductive silver epoxy or with a lower temperature solder perform, which is not rich in Sn content.

## Operation of the MA4AGSW8-1

The MA4AGSW8-1 switch is designed to operate in systems where lower D.C. current consumption and D.C. operating voltage are required. The application of either +10 mA or - 10 mA DC bias current to the selected port will provide the low insertion loss state. Typically this low loss, " ON " bias voltage through (3) series diodes is | 4.5 Volts | maximum. All Isolated Ports can be set to 0 V at 0 mA, or the application of | 5 V | back bias at 0 mA will improve the isolation and switching speed. RF to DC bias networks, (such as the MA4BN18-40) are required on all RF Ports.

A simple single supply, +5 V, PIN Diode TTL Gate Driver can be used to supply current for loss or 0 V back bias for isolation to switch the individual RF Ports. In this bias scheme, + 5 V through a current limiting resistor would be applied at the common port and each RF port would be connected to a TTL Gate. Low loss would occur when the Selected Gate Voltage is 0.5 V @ + 10 mA , " TTL 0 " and Isolation would occur when the Selected Gate Voltage is +5V @ 0mA (0 V Back Bias), " TTL 1 ".

For faster switching speeds (< 20 nS) , a +/- 5 V , PIN Diode TTL Driver should be employed to help remove the diode-stored charge with back bias. In this case, the common port is connected to D.C. Ground. Insertion Loss is achieved with - 10 mA @ - 4.5 V and Isolation is accomplished by applying + 5 V @ 0mA to the selected RF Ports respectively.

## Solder Die Attachment

All die attach and bonding methods should be compatible with gold metal. Solder which does not scavenge gold, such as 80Au/20Sn or Indalloy #2 is recommended. Do not expose die to a temperature greater than 300 °C for more than 10 seconds.

## Electrical Conductive Epoxy Die Attachment

Assembly can be preheated to approximately 125 °C. Use a controlled thickness of approximately 2 mils for best electrical and thermal conductivity and lower thermal resistance. Cure epoxy as per manufacturer's schedule. For extended cure times, temperatures should be kept below 150 °C.

## Ribbon/Wire Bonding

Wedge thermo compression bonding or ball bonding may be used to attach ribbons to the bonding pads. Gold ribbons should be 1/4 x 3 mil sq. for all RF ports for lowest inductance and best microwave performance.

MA4AGSW8-1 Schematic

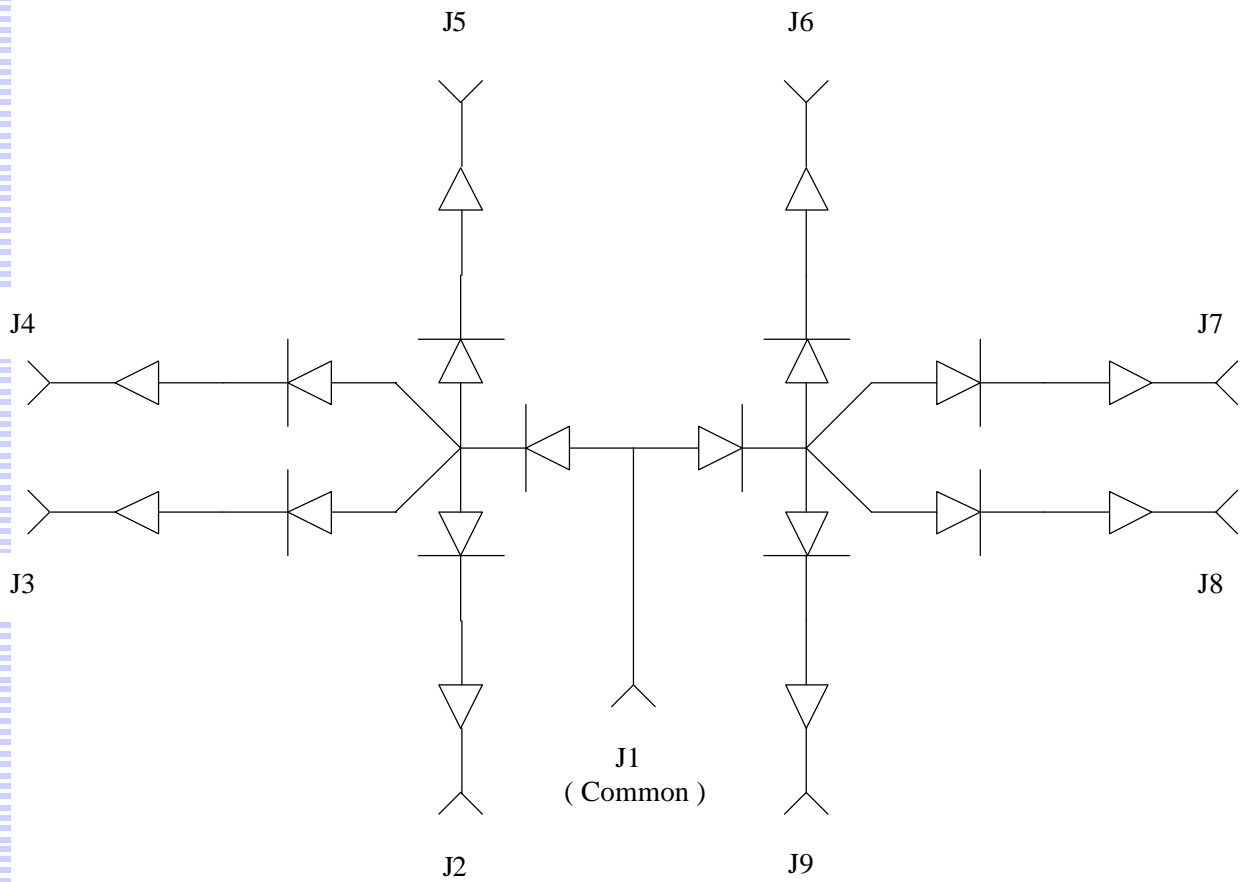

M/A-COM Inc. and its affiliates reserve the right to make changes to the product(s) or information contained herein without notice.

Visit [www.macom.com](http://www.macom.com) for additional data sheets and product information.

- North America: Tel. (800) 366-2266
- Asia/Pacific: Tel.+81-44-844-8296, Fax +81-44-844-8298
- Europe: Tel. +44 (1908) 574 200, Fax+44 (1908) 574 300

MA4AGSW8-1 Outline

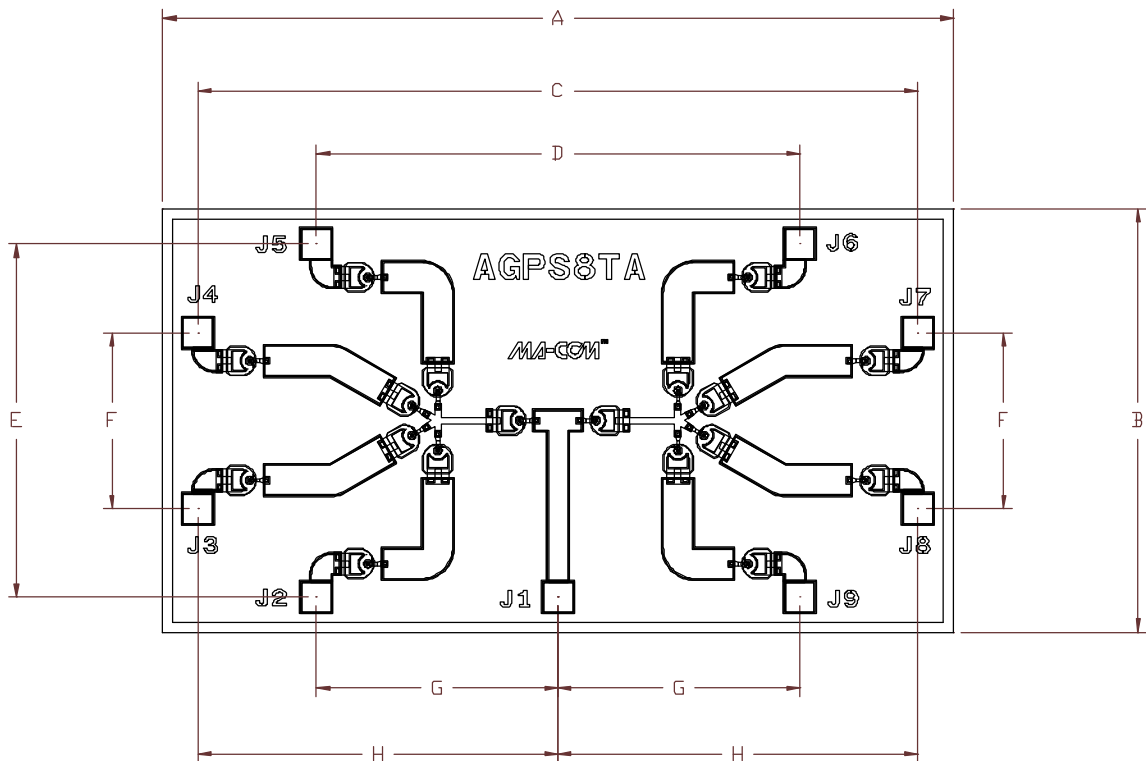

Dim	mm		mils	
	Min.	Max.	Min.	Max.
A	2.36	2.39	92.7	93.9
B	1.26	1.29	49.4	50.6
C	2.15	2.16	84.8	85.2
D	1.45	1.46	56.9	57.3
E	1.06	1.07	41.5	41.9
F	0.52	0.53	20.6	21.0
G	0.72	0.73	28.3	28.7
H	1.07	1.08	42.3	42.7
Thickness	0.09	0.11	3.7	4.3
Bonding Pads	100 μm x 100 μm, 5 μm Gold Thick			

M/A-COM Inc. and its affiliates reserve the right to make changes to the product(s) or information contained herein without notice.

Visit [www.macom.com](http://www.macom.com) for additional data sheets and product information.

- North America: Tel. (800) 366-2266
- Asia/Pacific: Tel.+81-44-844-8296, Fax +81-44-844-8298
- Europe: Tel. +44 (1908) 574 200, Fax+44 (1908) 574 300

