

REVISIONS			
LTR	DESCRIPTION	DATE	APPROVED
H1	REVISED PER ECO-11-005139	29MAR11	HMR

IF THIS DOCUMENT IS PRINTED IT BECOMES UNCONTROLLED.
CHECK FOR THE LATEST REVISION.

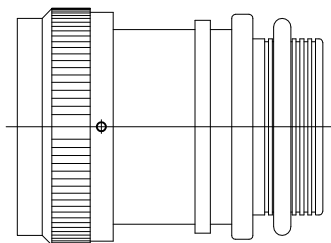

CODE 40 TINEL-LOCK ADAPTER

NOTES:

1. THIS PRODUCT IS DESIGNED TO TERMINATE A BRAIDED CABLE SHIELD AND A HEAT SHRINKABLE LIPPED BOOT TO A CONNECTOR.
2. SEE CH00-0250-008 FOR ORDERING INFORMATION, MODIFICATIONS AND ADDITIONAL DIMENSIONS.
- ③ SEE DRAWING "TR" FOR DETAILS ON TINEL-LOCK RING. RINGS ARE DESIGNED TO BE HEATED ELECTRICALLY. ALL RINGS ARE MARKED WITH THERMOCHROMIC PAINT WHICH CHANGES COLOR WHEN INSTALLATION TEMPERATURE IS REACHED.
4. ADAPTER TO BE PERMANENTLY MARKED WITH CODE IDENT. NO. AND PART NO. LESS RING DESIGNATOR (E.G.: 06090-TXR40AB00-1206). RINGS SHALL BEAR NO MARKING.
- ⑤ FOR LARGER ENTRY SIZES, A 2 PIECE ADAPTER (TYPE II) IS SUPPLIED.
- ⑥ ADAPTER MATES TO MIL-C-38999, SERIES III AND IV, CLASS C, F, K, AND W, D38999/20, /24, /26, /40, /46, /47 CONNECTORS, AND WHEN SO MATED SHALL PROVIDE A WATER-TIGHT SEAL MEETING THE REQUIREMENTS OF MIL-C-85049, PAR. 3.5.7.
- ⑦ THESE DIMENSIONS APPLY IF A SELF-LOCKING COUPLING NUT IS USED. (MOD. CODE "S").
- ⑧ COUPLING NUT SHALL HAVE 3 LOCK WIRE HOLES, 120° APART.

SPECIFICATION CONTROL DRAWING

UNLESS OTHERWISE SPECIFIED DIMENSIONS ARE IN INCHES. METRIC DIMENSIONS ARE IN BRACKETS. DECIMALS .XXX ± — [mm] .XX ± — [mm] .X ± — [mm] ANGLES .X ± —	DRAWN R. RAMIREZ	DATE 03-18-93		TE Connectivity 300 Constitution Drive Menlo Park, CA. 94025 U.S.A.		
	CHECKED	DATE				
	APPROVED W. C. GAY	DATE 05-19-93	TITLE TINEL-LOCK™ ADAPTER			
	APPROVED	DATE				
CAD NAME \ACAD12\TXR40						
THIRD ANGLE PROJECTION		SIZE A	CODE IDENT. NO. 06090	DWG. NO. TXR40	REV H1	
DO NOT SCALE THIS DWG				SHEET 1 OF 3		

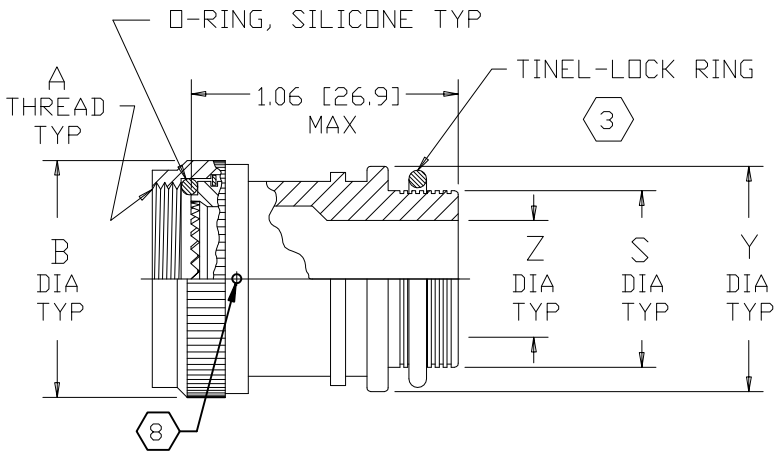

STRAIGHT ADAPTER-TYPE I

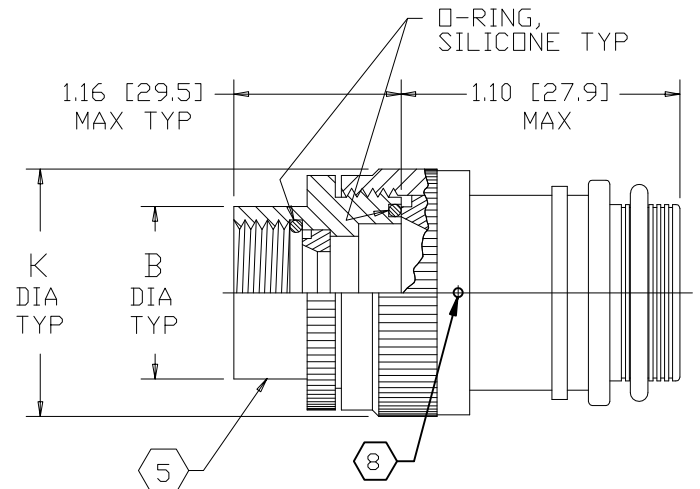

TYP STRAIGHT ADAPTER-TYPE II

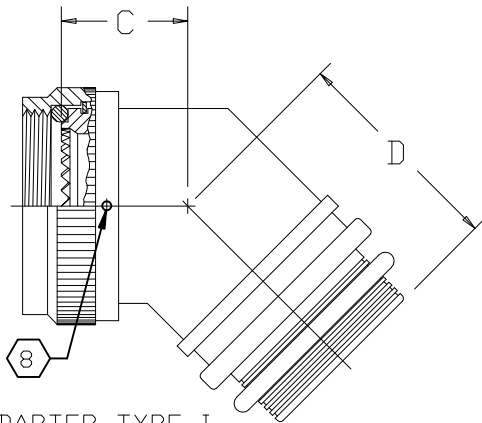

45° ADAPTER-TYPE I

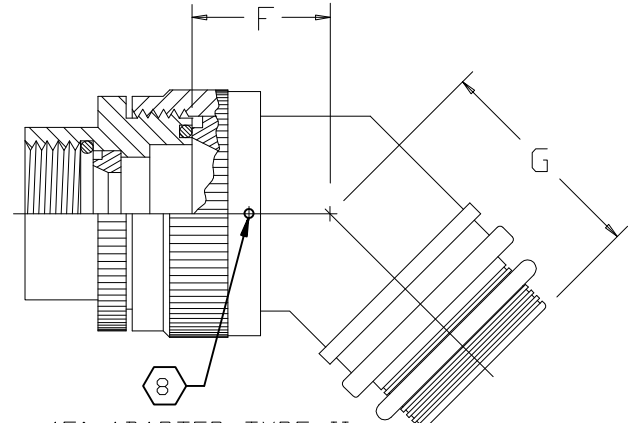

45° ADAPTER-TYPE II

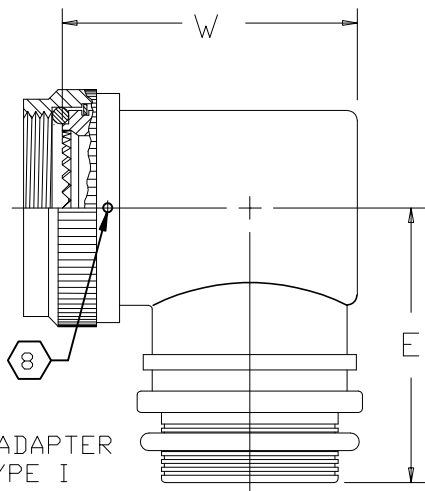

90° ADAPTER TYPE I

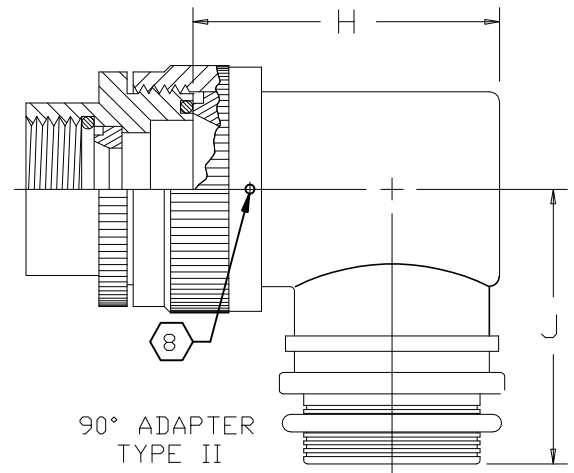

90° ADAPTER TYPE II

IF THIS DOCUMENT IS PRINTED IT BECOMES UNCONTROLLED.
CHECK FOR THE LATEST REVISION.

SIZE	CODE IDENT. NO.	DWG. NO.	REV
A	06090	TXR40	H1
DO NOT SCALE THIS DWG		CAD NAME \ACAD12\TXR40-2	SHEET 2 OF 3



TABLE I									
ORDER NO.	SHELL SIZE 		MAX ENTRY SIZE  TYPE I	A METRIC THD CLASS 6H	B DIA MAX	B DIA MAX 	C MAX	D MAX	E MAX
	COM'L	MIL							
08	9	A	04	M12 X 1.0	.750 [19.1]	.969 [24.6]	.82 [20.8]	.89 [22.6]	1.10 [27.9]
10	11	B	07	M15 X 1.0	.850 [21.6]	1.063 [27.0]	.84 [21.3]	.92 [23.4]	1.20 [30.5]
12	13	C	08	M18 X 1.0	1.000 [25.4]	1.219 [31.0]	.87 [22.1]	.95 [24.1]	1.26 [32.0]
14	15	D	10	M22 X 1.0	1.150 [29.2]	1.406 [35.7]	.89 [22.6]	.95 [24.1]	1.34 [34.0]
16	17	E	12	M25 X 1.0	1.250 [31.8]	1.469 [37.3]	.92 [23.4]	.98 [24.9]	1.40 [35.6]
18	19	F	14	M28 X 1.0	1.400 [35.6]	1.594 [40.5]	.95 [24.1]	1.01 [25.7]	1.45 [36.8]
20	21	G	16	M31 X 1.0	1.500 [38.1]	1.750 [44.5]	.97 [24.6]	1.04 [26.4]	1.51 [38.4]
22	23	H	18	M34 X 1.0	1.650 [41.9]	1.844 [46.8]	1.00 [25.4]	1.07 [27.2]	1.57 [39.9]
24	25	J	20	M37 X 1.0	1.750 [44.5]	2.031 [51.6]	1.02 [25.9]	1.07 [27.2]	1.67 [42.4]

TABLE II										
ENTRY SIZE	Z +.010 -.020	S DIA	Y ±.015 [±0.38]	W MAX	F MAX	G MAX	H MAX	J MAX	K MAX	
04	.250 [6.35]	.376 [9.56] .370 [9.39]	.550 [13.97]	1.23 [31.2]	N/A	N/A	N/A	N/A	N/A	
05	.312 [7.92]	.438 [11.13] .432 [10.97]	.612 [15.54]	1.29 [32.8]	.77 [19.6]	.93 [23.6]	1.19 [30.2]	1.16 [29.5]	.80 [20.3]	
06	.375 [9.52]	.501 [12.73] .495 [12.57]	.675 [17.14]	1.35 [34.3]	.77 [19.6]	.93 [23.6]	1.19 [30.2]	1.16 [29.5]	.80 [20.3]	
07	.437 [11.09]	.563 [14.31] .556 [14.12]	.737 [18.71]	1.42 [36.1]	.80 [20.3]	.95 [24.1]	1.38 [35.1]	1.22 [31.0]	.92 [23.4]	
08	.500 [12.70]	.626 [15.91] .619 [15.72]	.800 [20.32]	1.48 [37.6]	.80 [20.3]	.95 [24.1]	1.38 [35.1]	1.22 [31.0]	.92 [23.4]	
10	.625 [15.87]	.752 [19.11] .742 [18.84]	.925 [23.49]	1.60 [40.6]	.84 [21.3]	1.00 [25.4]	1.51 [38.4]	1.35 [34.3]	1.18 [30.0]	
12	.750 [19.05]	.877 [22.28] .867 [22.02]	1.050 [26.67]	1.73 [43.9]	.86 [21.8]	1.01 [25.7]	1.63 [41.4]	1.40 [35.6]	1.35 [34.3]	
14	.875 [22.23]	1.002 [25.46] .991 [25.17]	1.175 [29.84]	1.85 [47.0]	.88 [22.4]	1.04 [26.4]	1.78 [45.2]	1.46 [37.1]	1.41 [35.8]	
16	1.000 [25.40]	1.127 [28.63] 1.116 [28.34]	1.300 [33.02]	2.00 [50.8]	.91 [23.1]	1.06 [26.9]	1.88 [47.8]	1.53 [38.9]	1.60 [40.6]	
18	1.125 [28.57]	1.252 [31.81] 1.241 [31.52]	1.425 [36.19]	2.13 [54.1]	.93 [23.6]	1.09 [27.7]	2.01 [51.1]	1.59 [40.4]	1.66 [42.2]	
20	1.250 [31.75]	1.377 [34.98] 1.366 [34.69]	1.550 [39.37]	2.25 [57.2]	.98 [24.9]	1.13 [28.7]	2.13 [54.1]	1.78 [45.2]	2.04 [51.8]	
22	1.375 [34.93]	1.502 [38.15] 1.488 [37.79]	1.675 [42.55]	N/A	1.03 [26.2]	1.38 [35.1]	2.29 [58.2]	1.85 [47.0]	2.23 [56.6]	
24	1.500 [38.10]	1.627 [41.33] 1.613 [40.97]	1.800 [45.72]	N/A	1.08 [27.4]	1.44 [36.6]	2.42 [61.5]	1.92 [48.8]	2.23 [56.6]	

IF THIS DOCUMENT IS PRINTED IT BECOMES UNCONTROLLED.
CHECK FOR THE LATEST REVISION.

SIZE A	CODE IDENT. NO. 06090	DWG. NO. TXR40	REV H1
DO NOT SCALE THIS DWG		CAD NAME \\ACAD\TXR40-3	SHEET 3 OF 3