

MICROWAVE SEMICONDUCTOR TECHNICAL DATA

TMD1013-1

FEATURES

- High Power $P_{1dB}=33dBm(TYP.)$
- High Gain $G_{1dB}=25dB(TYP.)$
- High Power Added Efficiency $\eta_{add}=14%(TYP.)$
- Broadband Operation $f=10.0-13.3GHz.$

ABSOLUTE MAXIMUM RATINGS($T_a=25^\circ C$)

CHARACTERISTICS	SYMBOL	UNIT	RATINGS
DRAIN SUPPLY VOLTAGE	VDD	V	15
GATE SUPPLY VOLTAGE	VGG	V	-10
INPUT POWER	Pin	dB	15
FLANGE TEMPERATURE	Tf	°C	-30~+80
STORAGE TEMPERATURE	Tstg	°C	-65~+175

RF PERFORMANCE SPECIFICATIONS ($T_a=25^\circ C$)

CHARACTERISTICS	SYMBOL	CONDITION	UNIT	MIN.	TYP.	MAX.
Operating Frequency	f		GHz	10.0	—	13.3
Output Power at 1dB Gain Compression Point	P1dB	VDD=10V	dBm	31	33	—
Power Gain at 1dB Gain Compression Point	G1dB	VGG = -5V	dB	21	25	—
Gain Flatness	ΔG		dB	—	—	± 2.5
Drain Current	IDD		A	—	1.4	1.8
Power Added Efficiency	η_{add}		%	—	14	—
Third Order Intermodulation Distortion	IM3	2 Tone @ Po=19dBm(SCL)	dBc	-42	-45	—
VSWRin (small signal)	VSWRin		—	—	2.0	3.0

- ◆ The information contained herein is presented only as a guide for the applications of our products. No responsibility is assumed by TOSHIBA for any infringements of patents or other rights of the third parties which may result from its use. No license is granted by implication or otherwise under any patent or patent rights of TOSHIBA or others.
- ◆ The information contained herein may be changed without prior notice. It is therefore advisable to contact TOSHIBA before proceeding with design of equipment incorporating this product.

TMD1013-1

PACKAGE OUTLINE (2-9E1D)

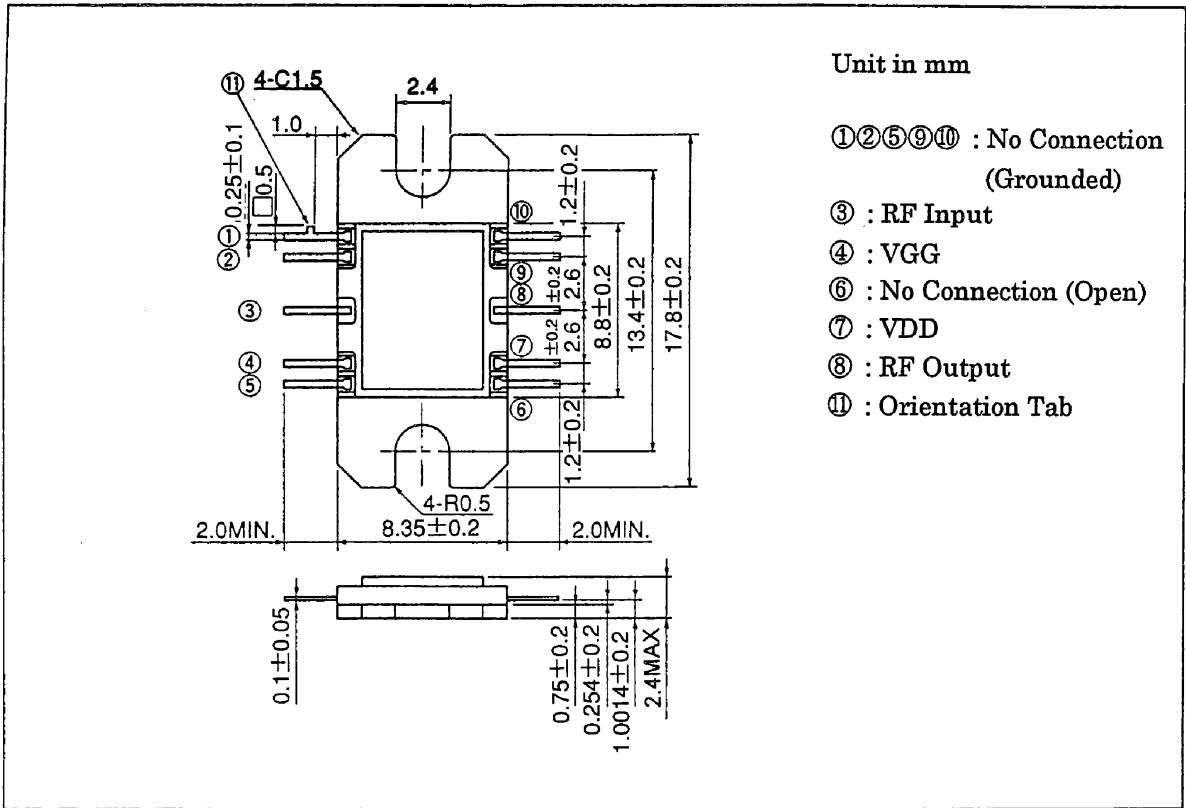

Recommended Bias Configuration

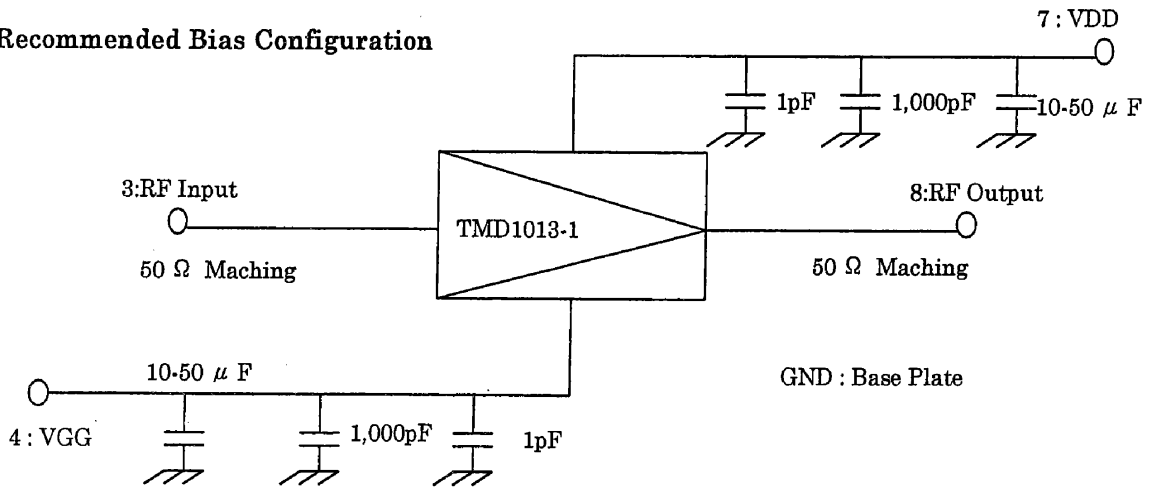

TMD1013-1

S-Parameters of TMD1013-1

VDD=10V, VGG=-5V

Freq. (GHz)	S11		S21		S12		S22	
	MAG	ANG	MAG	ANG	MAG	ANG	MAG	ANG
9.5	0.05	-137	16.5	-165	0.0002	101	0.22	-17
10.0	0.13	122	16.3	83	0.0004	92	0.19	-25
10.5	0.23	104	15.9	-20	0.0003	-23	0.19	-35
11.0	0.30	91	15.5	-122	0.0000	-47	0.13	-57
11.5	0.35	77	15.9	137	0.0004	-6	0.03	-103
12.0	0.34	55	16.7	31	0.0009	-70	0.08	124
12.5	0.27	34	17.2	-77	0.0016	-127	0.14	97
13.0	0.20	22	18.8	162	0.0020	174	0.20	91
13.5	0.20	-29	17.9	36	0.0013	151	0.16	45