

TL499A WIDE-RANGE POWER-SUPPLY CONTROLLERS

SLVS029G – JANUARY 1984 – REVISED SEPTEMBER 2001

- Internal Series-Pass and Step-Up Switching Regulator
- Output Adjustable From 2.9 V to 30 V
- 1-V to 10-V Input for Switching Regulator
- 4.5-V to 32-V Input for Series Regulator
- Externally Controlled Switching Current
- No External Rectifier Required

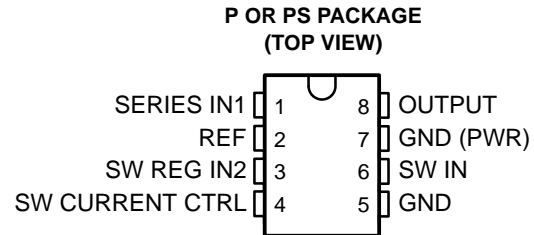

description

The TL499A is an integrated circuit designed to provide a wide range of adjustable regulated supply voltages. The regulated output voltage can be varied from 2.9 V to 30 V by adjusting two external resistors. When the TL499A is ac-coupled to line power through a step-down transformer, it operates as a series dc voltage regulator to maintain the regulated output voltage. With the addition of a battery from 1.1 V to 10 V, an inductor, a filter capacitor, and two resistors, the TL499A operates as a step-up switching regulator during an ac-line failure.

The adjustable regulated output voltage makes the TL499A useful for a wide range of applications. Providing backup power during an ac-line failure makes the TL499A extremely useful in microprocessor memory applications.

The TL499AC is characterized for operation from -20°C to 85°C .

AVAILABLE OPTIONS

T_A	PLASTIC DIP (P)	PLASTIC SMALL-OUTLINE (PS)
-20°C to 85°C	TL499ACP	TL499ACPS

The PS package is available taped and reeled. Add the suffix R to device type (e.g., TL499ACPSR).



Please be aware that an important notice concerning availability, standard warranty, and use in critical applications of Texas Instruments semiconductor products and disclaimers thereto appears at the end of this data sheet.

PRODUCTION DATA information is current as of publication date. Products conform to specifications per the terms of Texas Instruments standard warranty. Production processing does not necessarily include testing of all parameters.

 **TEXAS
INSTRUMENTS**

POST OFFICE BOX 655303 • DALLAS, TEXAS 75265

Copyright © 2001, Texas Instruments Incorporated

TL499A WIDE-RANGE POWER-SUPPLY CONTROLLERS

SLVS029G – JANUARY 1984 – REVISED SEPTEMBER 2001

functional block diagram

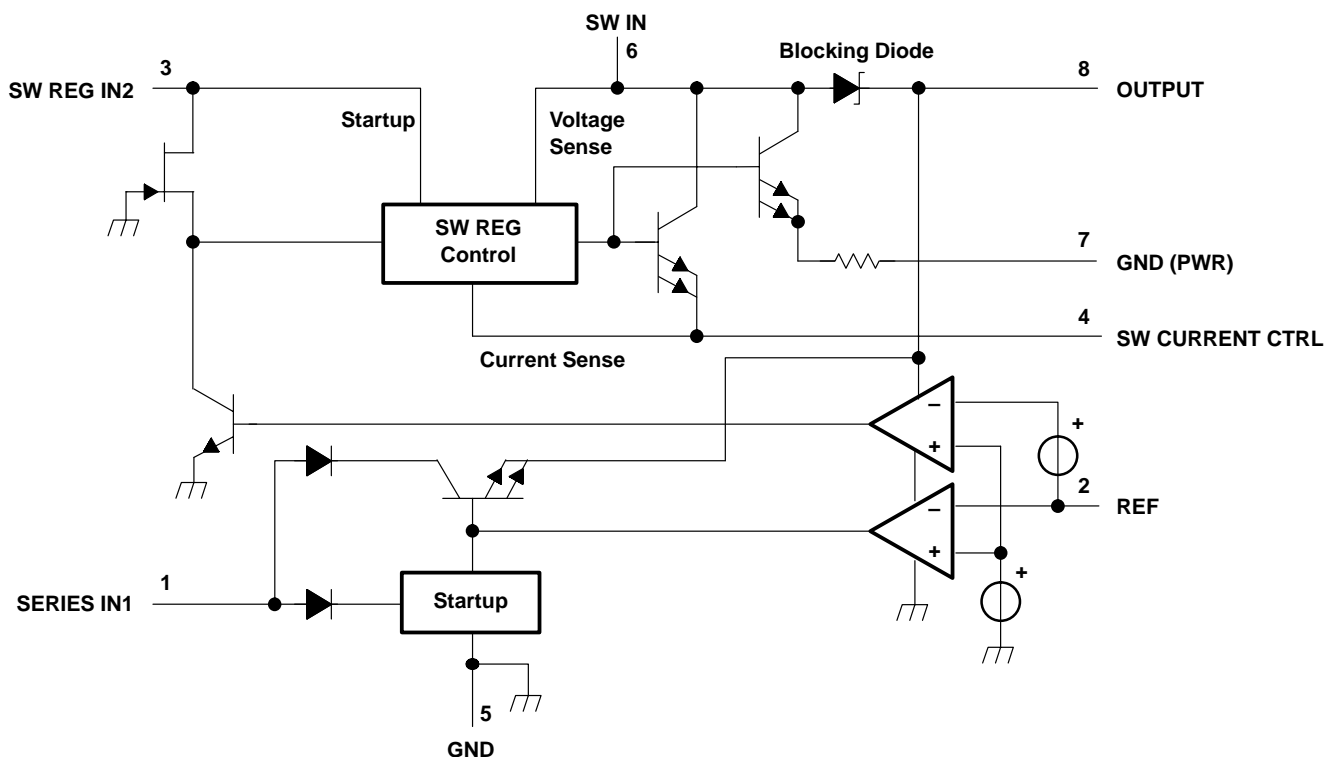

absolute maximum ratings over operating free-air temperature range (unless otherwise noted)†

Output voltage, V_O (see Note 1)	35 V
Input voltage, series regulator, V_{I1}	35 V
Input voltage, switching regulator, V_{I2}	10 V
Blocking-diode reverse voltage	35 V
Blocking-diode forward current	1 A
Power switch current (SW IN)	1 A
Package thermal impedance, θ_{JA} (see Notes 2 and 3): P package	85°C/W
PS package	95°C/W
Lead temperature 1,6 mm (1/16 inch) from case for 10 seconds	260°C
Storage temperature range, T_{stg}	-65°C to 150°C

† Stresses beyond those listed under “absolute maximum ratings” may cause permanent damage to the device. These are stress ratings only, and functional operation of the device at these or any other conditions beyond those indicated under “recommended operating conditions” is not implied. Exposure to absolute-maximum-rated conditions for extended periods may affect device reliability.

- NOTES:
- All voltage values are with respect to network ground terminal.
 - Maximum power dissipation is a function of $T_J(\max)$, θ_{JA} , and T_A . The maximum allowable power dissipation at any allowable ambient temperature is $P_D = (T_J(\max) - T_A)/\theta_{JA}$. Operating at the absolute maximum T_J of 150°C can affect reliability.
 - The package thermal impedance is calculated in accordance with JESD 51-7.



POST OFFICE BOX 655303 • DALLAS, TEXAS 75265

TL499A WIDE-RANGE POWER-SUPPLY CONTROLLERS

SLVS029G – JANUARY 1984 – REVISED SEPTEMBER 2001

recommended operating conditions

	MIN	NOM	MAX	UNIT
Output voltage, V_O	2.9		30	V
Input voltage, V_{I1} (SERIES IN1)	4.5		32	V
Input voltage, V_{I2} (SW REG IN2)	1.1		10	V
Output-to-input differential voltage, switching regulator, $V_O - V_{I2}$ (see Note 4)	1.2		28.9	V
Continuous output current, I_O			100	mA
Power switch current (at SW IN)			500	mA
Current-limiting resistor, R_{CL}	150		1000	Ω
Filter capacitor	100		470	μF
Pass capacitor		0.1		μF
Inductor, L (dcr $\leq 0.1 \Omega$)	50		150	μH
Operating free-air temperature, T_A	-20		85	$^{\circ}\text{C}$

NOTE 4: When operating temperature range is $T_A \leq 70^{\circ}\text{C}$, minimum $V_O - V_{I2}$ is $\geq 1.2\text{ V}$. When operating temperature range is $T_A \leq 85^{\circ}\text{C}$, minimum $V_O - V_{I2}$ is $\geq 1.9\text{ V}$.

electrical characteristics over recommended operating conditions (unless otherwise noted)

PARAMETER		TEST CONDITIONS	TL499AC			UNIT
			MIN	TYP	MAX	
Voltage deviation (see Note 5)				20	30	mV/V
$V_O - V_{I2}$	Switching regulator	$T_A = -20^{\circ}\text{C}$ to 70°C	1.2			V
		$T_A = -20^{\circ}\text{C}$ to 85°C	1.9			
Dropout voltage	Series regulator	$V_{I1} = 15\text{ V}$, $I_O = 50\text{ mA}$			1.8	
Reference voltage (internal)		$V_{I1} = 5\text{ V}$, $V_O = 3\text{ V}$, $I_O = 1\text{ mA}$	1.2	1.26	1.32	V
Reference-voltage change with temperature				5	10	mV/V
Output regulation (of reference voltage)		$I_O = 1\text{ mA}$ to 50 mA		10	30	mV/V
Output current (see Figure 1)	Switching regulator	$V_{I2} = 1.1\text{ V}$, $V_O = 12\text{ V}$, $R_{CL} = 150\ \Omega$, $T_A = 25^{\circ}\text{C}$			10	mA
		$V_{I2} = 1.5\text{ V}$, $V_O = 15\text{ V}$, $R_{CL} = 150\ \Omega$, $T_A = 25^{\circ}\text{C}$			15	
		$V_{I2} = 6\text{ V}$, $V_O = 30\text{ V}$, $R_{CL} = 150\ \Omega$, $T_A = 25^{\circ}\text{C}$			65	
	Series regulator			100		
Standby current	Switching regulator	$V_{I2} = 3\text{ V}$, $V_O = 9\text{ V}$, $T_A = 25^{\circ}\text{C}$		15	80	μA
	Series regulator	$V_{I1} = 15\text{ V}$, $V_O = 9\text{ V}$, $R_{E2} = 4.7\text{ k}\Omega$		0.8	1.2	mA

NOTE 5: Voltage deviation is the output voltage difference that occurs in a change from series regulation to switching regulation:
Voltage deviation = $V_O(\text{series regulation}) - V_O(\text{switching regulation})$



TL499A WIDE-RANGE POWER-SUPPLY CONTROLLERS

SLVS029G – JANUARY 1984 – REVISED SEPTEMBER 2001

APPLICATION INFORMATION

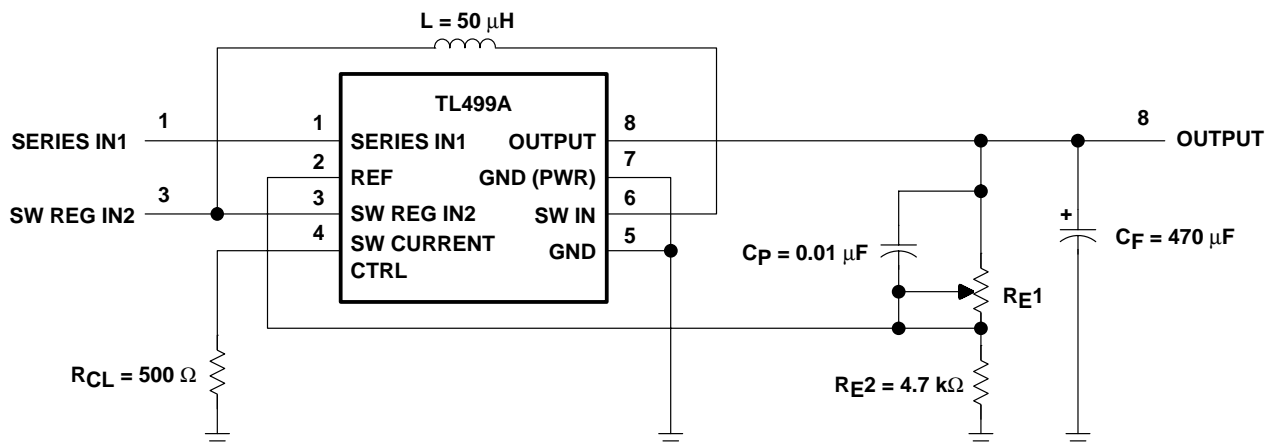

Figure 1. TL499A Basic Configuration

Table 1. Maximum Output Current vs Input and Output Voltages
for Step-Up Switching Regulator With $R_{CL} = 150 \Omega$

OUTPUT VOLTAGE (V)	SWITCHING REGULATOR INPUT VOLTAGE (SW REG IN2) (V)										
	1.1	1.2	1.3	1.5	1.7	2	2.5	3	5	6	9
	OUTPUT CURRENT (mA)										
30										65	90
25									50	80	100
20						20	25	30	80	100	100
15				15	20	30	45	55	100	100	100
12	10	15	20	25	30	40	55	70	100	100	100
10	15	20	25	30	35	45	65	80	100	100	
9	20	25	25	35	40	50	70	90	100	100	
6	30	35	40	45	55	75	95	100			
5	35	40	45	55	70	85	100	100	Circuit of Figure 1, except: $R_{CL} = 150 \Omega$ $C_F = 330 \mu F$ $C_P = 0.1 \mu F$		
4.5	35	45	50	60	75	95	100	100†			
3	55	65†	75†	95†	100†						
2.9	60†	70†	75†	100†	100†						

† The difference between the output and input voltage for these combinations is greater than the minimum output-to-input differential-voltage specification at 70°C (1.2 V), but less than the minimum at 85°C (1.9 V).

APPLICATION INFORMATION

**Table 2. Maximum Output Current vs Input and Output Voltages
for Step-Up Switching Regulator With $R_{CL} = 200 \Omega$**

OUTPUT VOLTAGE (V)	SWITCHING REGULATOR INPUT VOLTAGE (SW REG IN2) (V)										
	1.1	1.2	1.3	1.5	1.7	2	2.5	3	5	6	9
	OUTPUT CURRENT (mA)										
30										50	100
25									50	70	100
20						15	25	30	70	90	100
15				10	15	25	35	45	90	100	100
12	10	10	15	20	25	35	45	60	100	100	100
10	15	20	20	25	30	40	55	70	100	100	
9	20	20	25	30	35	45	60	80	100		
6	25	30	35	45	50	65	90	100			
5	30	35	40	55	60	75	100	100	Circuit of Figure 1, except: $R_{CL} = 200 \Omega$ $C_F = 330 \mu F$ $C_P = 0.1 \mu F$		
4.5	35	40	45	55	65	85	100	100†			
3	50	55†	65†	80†	90†						
2.9	50†	60†	65†	85†	100†						

† The difference between the output and input voltage for these combinations is greater than the minimum output-to-input differential-voltage specification at 70°C (1.2 V), but less than the minimum at 85°C (1.9 V).

**Table 3. Maximum Output Current vs Input and Output Voltages
for Step-Up Switching Regulator With $R_{CL} = 300 \Omega$**

OUTPUT VOLTAGE (V)	SWITCHING REGULATOR INPUT VOLTAGE (SW REG IN2) (V)										
	1.1	1.2	1.3	1.5	1.7	2	2.5	3	5	6	9
	OUTPUT CURRENT (mA)										
30										40	70
25									40	55	100
20						10	15	20	55	70	100
15				10	10	20	30	35	75	95	100
12	10	10	10	15	20	25	35	45	95	100	100
10	15	15	15	20	25	30	45	55	100	100	
9	15	15	20	25	30	35	50	60	100	100	
6	25	25	30	35	45	55	70	90			
5	30	30	35	45	50	65	85	100	Circuit of Figure 1, except: $R_{CL} = 300 \Omega$ $C_F = 330 \mu F$ $C_P = 0.1 \mu F$		
4.5	30	35	40	45	55	70	95	100†			
3	45	50†	55†	70†	90†						
2.9	45†	50†	60†	75†	95†						

† The difference between the output and input voltage for these combinations is greater than the minimum output-to-input differential-voltage specification at 70°C (1.2 V), but less than the minimum at 85°C (1.9 V).

TL499A WIDE-RANGE POWER-SUPPLY CONTROLLERS

SLVS029G – JANUARY 1984 – REVISED SEPTEMBER 2001

APPLICATION INFORMATION

Table 4. Maximum Output Current vs Input and Output Voltages for Step-Up Switching Regulator With $R_{CL} = 510 \Omega$

OUTPUT VOLTAGE (V)	SWITCHING REGULATOR INPUT VOLTAGE (SW REG IN2) (V)										
	1.1	1.2	1.3	1.5	1.7	2	2.5	3	5	6	9
	OUTPUT CURRENT (mA)										
30										30	50
25									25	40	75
20									40	55	90
15							15	20	55	70	100
12					10	15	25	35	65	80	100
10				10	20	25	30	40	70	85	
9	10	10	10	15	20	25	35	45	75	100	
6	15	20	20	25	30	35	50	60			
5	20	20	25	30	35	45	55	70	Circuit of Figure 1, except: $R_{CL} = 510 \Omega$ $C_F = 330 \mu F$ $C_P = 0.1 \mu F$		
4.5	20	25	30	35	40	50	65	90 [†]			
3	35	35 [†]	40 [†]	50 [†]	75 [†]						
2.9	35 [†]	35 [†]	40 [†]	55 [†]	80 [†]						

[†] The difference between the output and input voltage for these combinations is greater than the minimum output-to-input differential-voltage specification at 70°C (1.2 V), but less than the minimum at 85°C (1.9 V).

Table 5. Maximum Output Current vs Input and Output Voltages for Step-Up Switching Regulator With $R_{CL} = 1 k\Omega$

OUTPUT VOLTAGE (V)	SWITCHING REGULATOR INPUT VOLTAGE (SW REG IN2) (V)										
	1.1	1.2	1.3	1.5	1.7	2	2.5	3	5	6	9
	OUTPUT CURRENT (mA)										
30											35
25										35	50
20										35	60
15								10	30	45	65
12								20	40	45	85
10							15	25	40	55	
9				10	10	15	25	30	45	60	
6	10	10	10	15	20	20	30	35			
5	10	10	15	20	20	25	35	40	Circuit of Figure 1, except: $R_{CL} = 1 k\Omega$ $C_F = 330 \mu F$ $C_P = 0.1 \mu F$		
4.5	15	15	15	20	25	30	40	45 [†]			
3	20	25 [†]	25 [†]	30 [†]	35 [†]						
2.9	20 [†]	25 [†]	25 [†]	30 [†]	45 [†]						

[†] The difference between the output and input voltage for these combinations is greater than the minimum output-to-input differential-voltage specification at 70°C (1.2 V), but less than the minimum at 85°C (1.9 V).



POST OFFICE BOX 655303 • DALLAS, TEXAS 75265

PACKAGING INFORMATION

Orderable Device	Status ⁽¹⁾	Package Type	Package Drawing	Pins	Package Qty	Eco Plan ⁽²⁾	Lead/Ball Finish	MSL Peak Temp ⁽³⁾
TL499ACP	ACTIVE	PDIP	P	8	50	Pb-Free (RoHS)	CU NIPDAU	N / A for Pkg Type
TL499ACPE4	ACTIVE	PDIP	P	8	50	Pb-Free (RoHS)	CU NIPDAU	N / A for Pkg Type
TL499ACPSR	ACTIVE	SO	PS	8	2000	Green (RoHS & no Sb/Br)	CU NIPDAU	Level-1-260C-UNLIM
TL499ACPSRE4	ACTIVE	SO	PS	8	2000	Green (RoHS & no Sb/Br)	CU NIPDAU	Level-1-260C-UNLIM
TL499ACPSRG4	ACTIVE	SO	PS	8	2000	Green (RoHS & no Sb/Br)	CU NIPDAU	Level-1-260C-UNLIM

⁽¹⁾ The marketing status values are defined as follows:

ACTIVE: Product device recommended for new designs.

LIFEBUY: TI has announced that the device will be discontinued, and a lifetime-buy period is in effect.

NRND: Not recommended for new designs. Device is in production to support existing customers, but TI does not recommend using this part in a new design.

PREVIEW: Device has been announced but is not in production. Samples may or may not be available.

OBSOLETE: TI has discontinued the production of the device.

⁽²⁾ Eco Plan - The planned eco-friendly classification: Pb-Free (RoHS), Pb-Free (RoHS Exempt), or Green (RoHS & no Sb/Br) - please check <http://www.ti.com/productcontent> for the latest availability information and additional product content details.

TBD: The Pb-Free/Green conversion plan has not been defined.

Pb-Free (RoHS): TI's terms "Lead-Free" or "Pb-Free" mean semiconductor products that are compatible with the current RoHS requirements for all 6 substances, including the requirement that lead not exceed 0.1% by weight in homogeneous materials. Where designed to be soldered at high temperatures, TI Pb-Free products are suitable for use in specified lead-free processes.

Pb-Free (RoHS Exempt): This component has a RoHS exemption for either 1) lead-based flip-chip solder bumps used between the die and package, or 2) lead-based die adhesive used between the die and leadframe. The component is otherwise considered Pb-Free (RoHS compatible) as defined above.

Green (RoHS & no Sb/Br): TI defines "Green" to mean Pb-Free (RoHS compatible), and free of Bromine (Br) and Antimony (Sb) based flame retardants (Br or Sb do not exceed 0.1% by weight in homogeneous material)

⁽³⁾ MSL, Peak Temp. -- The Moisture Sensitivity Level rating according to the JEDEC industry standard classifications, and peak solder temperature.

Important Information and Disclaimer:The information provided on this page represents TI's knowledge and belief as of the date that it is provided. TI bases its knowledge and belief on information provided by third parties, and makes no representation or warranty as to the accuracy of such information. Efforts are underway to better integrate information from third parties. TI has taken and continues to take reasonable steps to provide representative and accurate information but may not have conducted destructive testing or chemical analysis on incoming materials and chemicals. TI and TI suppliers consider certain information to be proprietary, and thus CAS numbers and other limited information may not be available for release.

In no event shall TI's liability arising out of such information exceed the total purchase price of the TI part(s) at issue in this document sold by TI to Customer on an annual basis.

TAPE AND REEL INFORMATION



QUADRANT ASSIGNMENTS FOR PIN 1 ORIENTATION IN TAPE



*All dimensions are nominal

Device	Package Type	Package Drawing	Pins	SPQ	Reel Diameter (mm)	Reel Width W1 (mm)	A0 (mm)	B0 (mm)	K0 (mm)	P1 (mm)	W (mm)	Pin1 Quadrant
TL499ACPSR	SO	PS	8	2000	330.0	16.4	8.2	6.6	2.5	12.0	16.0	Q1

TAPE AND REEL BOX DIMENSIONS



*All dimensions are nominal

Device	Package Type	Package Drawing	Pins	SPQ	Length (mm)	Width (mm)	Height (mm)
TL499ACPSR	SO	PS	8	2000	346.0	346.0	33.0

P (R-PDIP-T8)

PLASTIC DUAL-IN-LINE PACKAGE

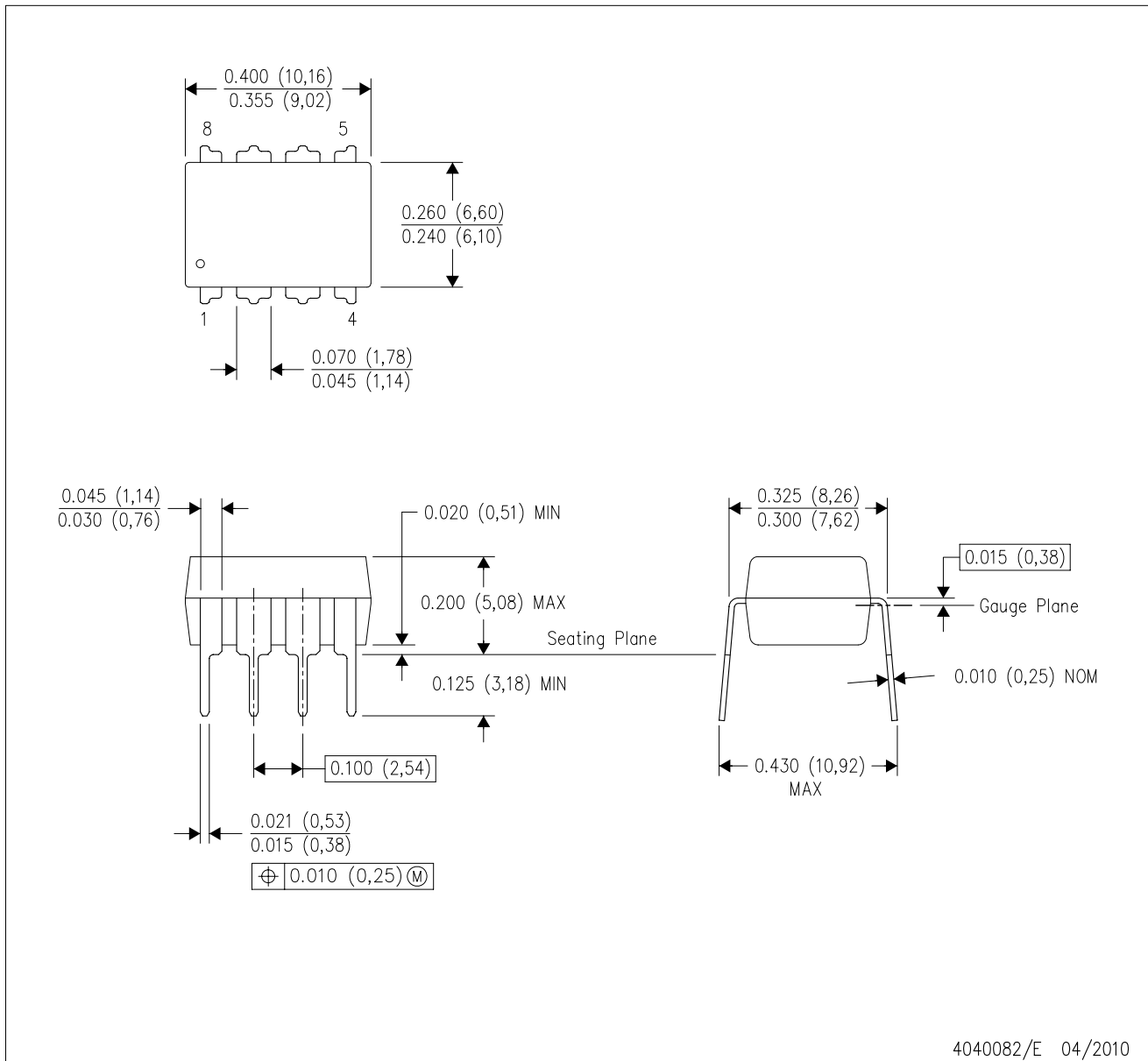

- NOTES:
- A. All linear dimensions are in inches (millimeters).
 - B. This drawing is subject to change without notice.
 - C. Falls within JEDEC MS-001 variation BA.

MECHANICAL DATA

PS (R-PDSO-G8)

PLASTIC SMALL-OUTLINE PACKAGE

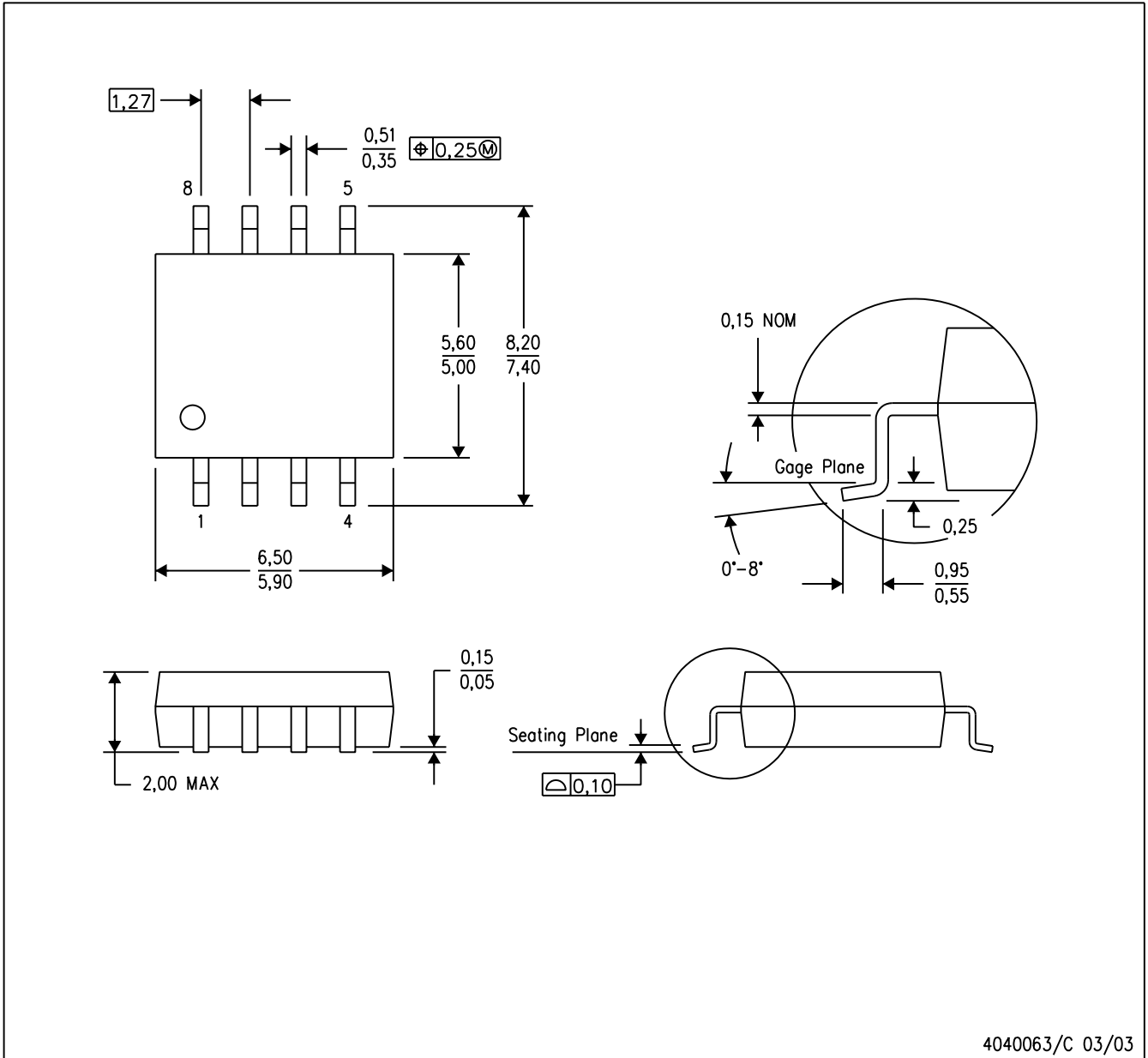

- NOTES:
- All linear dimensions are in millimeters.
 - This drawing is subject to change without notice.
 - Body dimensions do not include mold flash or protrusion, not to exceed 0,15.

IMPORTANT NOTICE

Texas Instruments Incorporated and its subsidiaries (TI) reserve the right to make corrections, modifications, enhancements, improvements, and other changes to its products and services at any time and to discontinue any product or service without notice. Customers should obtain the latest relevant information before placing orders and should verify that such information is current and complete. All products are sold subject to TI's terms and conditions of sale supplied at the time of order acknowledgment.

TI warrants performance of its hardware products to the specifications applicable at the time of sale in accordance with TI's standard warranty. Testing and other quality control techniques are used to the extent TI deems necessary to support this warranty. Except where mandated by government requirements, testing of all parameters of each product is not necessarily performed.

TI assumes no liability for applications assistance or customer product design. Customers are responsible for their products and applications using TI components. To minimize the risks associated with customer products and applications, customers should provide adequate design and operating safeguards.

TI does not warrant or represent that any license, either express or implied, is granted under any TI patent right, copyright, mask work right, or other TI intellectual property right relating to any combination, machine, or process in which TI products or services are used. Information published by TI regarding third-party products or services does not constitute a license from TI to use such products or services or a warranty or endorsement thereof. Use of such information may require a license from a third party under the patents or other intellectual property of the third party, or a license from TI under the patents or other intellectual property of TI.

Reproduction of TI information in TI data books or data sheets is permissible only if reproduction is without alteration and is accompanied by all associated warranties, conditions, limitations, and notices. Reproduction of this information with alteration is an unfair and deceptive business practice. TI is not responsible or liable for such altered documentation. Information of third parties may be subject to additional restrictions.

Resale of TI products or services with statements different from or beyond the parameters stated by TI for that product or service voids all express and any implied warranties for the associated TI product or service and is an unfair and deceptive business practice. TI is not responsible or liable for any such statements.

TI products are not authorized for use in safety-critical applications (such as life support) where a failure of the TI product would reasonably be expected to cause severe personal injury or death, unless officers of the parties have executed an agreement specifically governing such use. Buyers represent that they have all necessary expertise in the safety and regulatory ramifications of their applications, and acknowledge and agree that they are solely responsible for all legal, regulatory and safety-related requirements concerning their products and any use of TI products in such safety-critical applications, notwithstanding any applications-related information or support that may be provided by TI. Further, Buyers must fully indemnify TI and its representatives against any damages arising out of the use of TI products in such safety-critical applications.

TI products are neither designed nor intended for use in military/aerospace applications or environments unless the TI products are specifically designated by TI as military-grade or "enhanced plastic." Only products designated by TI as military-grade meet military specifications. Buyers acknowledge and agree that any such use of TI products which TI has not designated as military-grade is solely at the Buyer's risk, and that they are solely responsible for compliance with all legal and regulatory requirements in connection with such use.

TI products are neither designed nor intended for use in automotive applications or environments unless the specific TI products are designated by TI as compliant with ISO/TS 16949 requirements. Buyers acknowledge and agree that, if they use any non-designated products in automotive applications, TI will not be responsible for any failure to meet such requirements.

Following are URLs where you can obtain information on other Texas Instruments products and application solutions:

Products		Applications	
Amplifiers	amplifier.ti.com	Audio	www.ti.com/audio
Data Converters	dataconverter.ti.com	Automotive	www.ti.com/automotive
DLP® Products	www.dlp.com	Communications and Telecom	www.ti.com/communications
DSP	dsp.ti.com	Computers and Peripherals	www.ti.com/computers
Clocks and Timers	www.ti.com/clocks	Consumer Electronics	www.ti.com/consumer-apps
Interface	interface.ti.com	Energy	www.ti.com/energy
Logic	logic.ti.com	Industrial	www.ti.com/industrial
Power Mgmt	power.ti.com	Medical	www.ti.com/medical
Microcontrollers	microcontroller.ti.com	Security	www.ti.com/security
RFID	www.ti-rfid.com	Space, Avionics & Defense	www.ti.com/space-avionics-defense
RF/IF and ZigBee® Solutions	www.ti.com/lprf	Video and Imaging	www.ti.com/video
		Wireless	www.ti.com/wireless-apps

Mailing Address: Texas Instruments, Post Office Box 655303, Dallas, Texas 75265
Copyright © 2010, Texas Instruments Incorporated