

# McGILL® 0801, 0811, 0821, 0831 Series Metal-Mount Style Rocker Switches



The McGill® 0801, 0811, 0821 and 0831 series feature industrial grade construction with electrical ratings up to 25A @ 277VAC. Available with a variety of screw or snap mount metal brackets, the 0801, 0811, 0821, and 0831 series provide a robust design for the requirements of industrial type applications.

## Specifications

### 0801

- UL recognized
  - 20A, 277VAC
  - 1 1/2 HP, 125-250VAC
- CSA certified
  - 16A, 277VAC
  - 1 1/2 HP, 125-250VAC

### 0811 \*/0821/0831 Series

- UL recognized
  - 15A, 277VAC
  - 3/4 HP, 125-277VAC
- CSA certified
  - 15A, 277VAC
  - 3/4 HP, 125-250VAC

\*DPST only circuit available in 20A, 277VAC @ 1 1/2 HP, 125-250VAC

## Construction

- All standard models have .250 x .032 spade terminals and white actuators. Coverplate versions have .375 offset, 1.625 centered 2-hole mounting.
- .187 spade terminals, solder terminals and 16-gauge wire leads are also available. Consult factory for other circuits, colors or custom designs.

### Snap-In Version

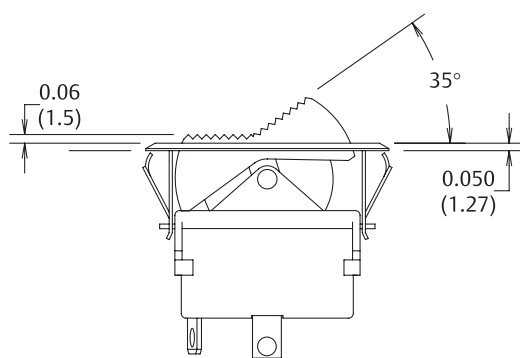

### Coverplate Version

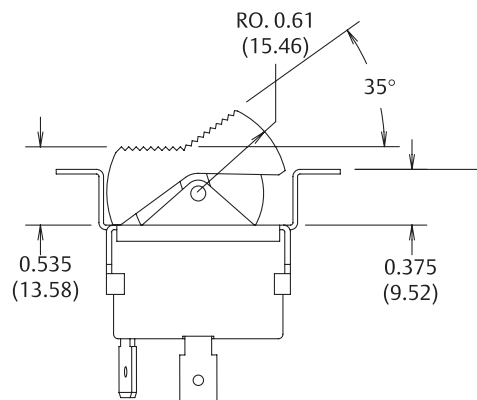



## Metal-Mount Standard Models

Circuit Arrangement			SINGLE POLE			DOUBLE POLE		
			Cat. No.			Cat. No.		
			Poles	.375" Offset Coverplate	Snap-in Bezel*	Poles	.375" Offset Coverplate	Snap-in Bezel*
on	—	off	SPST	0801-0310	0801-1310	DPST	0811-0310	0811-1310
on	off	on	SPDT	0801-0311	0801-1311	DPDT	0831-0311	0831-1311
on	—	on	SPDT	0801-0312	0801-1312	DPDT	0831-0312	0831-1312
(on)	—	off	SPST	0821-0313	0821-1313	DPST	0831-0313	0831-1313
(on)	off	(on)	SPDT	0821-0314	0821-1314	DPDT	0831-0314	0831-1314
(on)	off	on	SPDT	0821-0316	0821-1316	DPDT	0831-0316	0831-1316
on	—	(off)	SPST	0821-0317	0821-1317	DPST	0831-0317	0831-1317
(on)	—	on	SPDT	0821-0318	0821-1318	DPDT	0831-0318	0831-1318

( ) Momentary

\*PANEL THICKNESS

Nominal	Range
.046"	.039"-.052"
.060"	.056"-.071"
.090"	.082"-.096"
.187"	.180"-.199"

For positive locking, specify exact panel thickness.

## Coverplate Variations

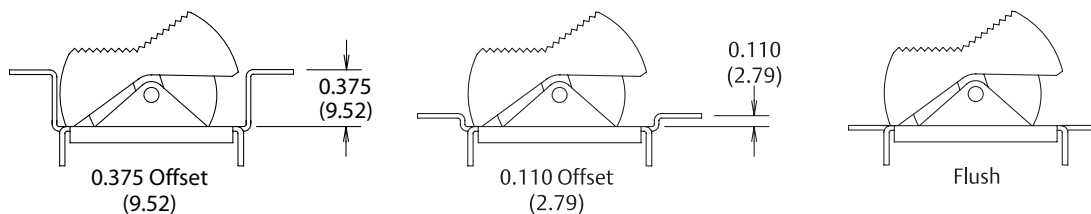

Approximate dimensions in inches and (millimeters).

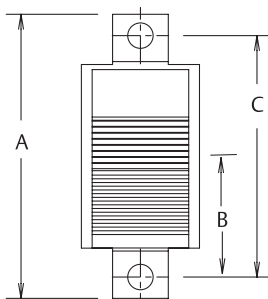

Coverplate	Mounting Holes	A	B	C
Flush	.171" dia.	2.500"	1.000"	2.000"
	tap 6 - 32	1.912"	.812"	1.625"
.110" offset	.171" dia.	2.500"	1.000"	2.000"
	tap 6 - 32	1.912"	.812"	1.625"
.375" offset	.171" dia.	2.500"	1.000"	2.000"
	tap 6 - 32	1.912"	.812"	1.625"