

Phase Shift Resonant Controller

FEATURES

- Programmable Output Turn On Delay; Zero Delay Available
- Compatible with Voltage Mode or Current Mode Topologies
- Practical Operation at Switching Frequencies to 300kHz
- Four 100mA Totem Pole Outputs
- 10MHz Error Amplifier
- Pin Programmable Undervoltage Lockout
- Low Startup Current - 150µA
- Soft Start Control
- Outputs Active Low During UVLO

DESCRIPTION

The UC3879 controls a bridge power stage by phase shifting the switching of one half-bridge with respect to the other. This allows constant frequency pulse width modulation in combination with resonant, zero-voltage switching for high efficiency performance. The UC3879 can be configured to provide control in either voltage mode or current mode operation, with overcurrent shutdown for fast fault protection.

Independently programmable time delays provide dead-time at the turn-on of each output stage, allowing time for each resonant switching interval.

With the oscillator capable of operating in excess of 600kHz, overall output switching frequencies to 300kHz are practical. In addition to the standard free running mode, with the CLKS SYNC pin, the user may configure the UC3879 to accept an external clock synchronization signal. Alternatively, up to three units can be locked together with the operational frequency determined by the fastest device.

Protective features include an undervoltage lockout and overcurrent protection. Additional features include a 10MHz error amplifier, a 5V precision reference, and soft start. The UC3879 is available in 20 pin N, J, DW, and Q and 28 pin L packages.

BLOCK DIAGRAM

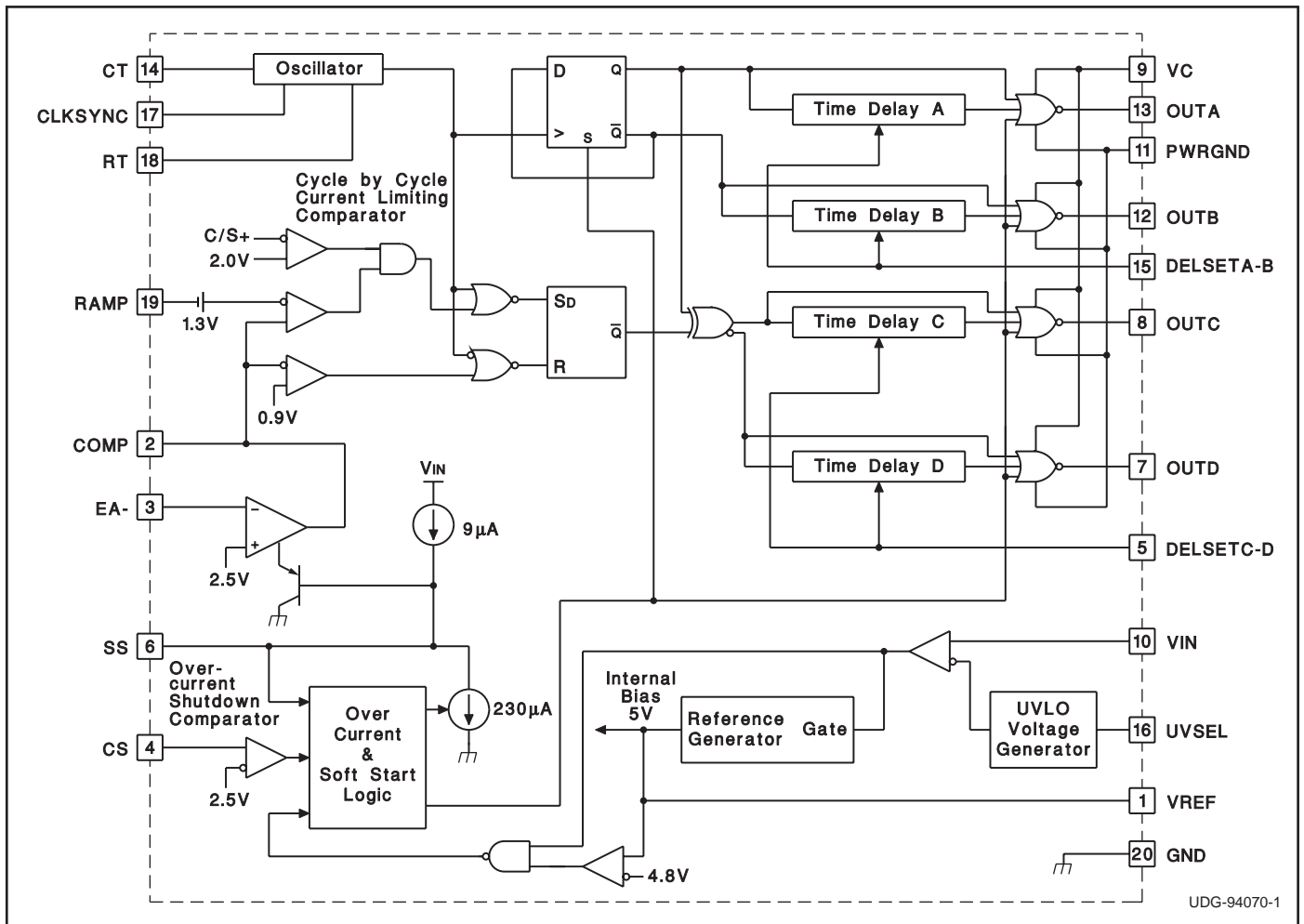

ABSOLUTE MAXIMUM RATINGS

Supply Voltage (VC, VIN) 20V
 Output Current, Source or Sink, DC 20mA
 Analog I/Os
 (Pins 1, 2, 3, 4, 5, 6, 14, 15, 17, 18, 19) -0.3 to 5.3V
 (Pin 16) -0.3V to VIN
 Storage Temperature Range -65°C to +150°C
 Junction Temperature -55°C to +150°C
 Lead Temperature (Soldering, 10 sec.) +300°C

Notes: Pin references are to 20 pin DIL and SOIC packages.
 All voltages are with respect to ground unless otherwise stated.
 Currents are positive into, negative out of the specified terminal.
 Consult Packaging Section of Databook for thermal limitations and considerations of packages.

Table I. Product Selection Guide

	TEMPERATURE RANGE	AVAILABLE PACKAGES
UCC1879	-55°C to +125°C	J, L
UCC2879	-40°C to +85°C	N, DW, Q, J, L
UCC3879	0°C to +70°C	N, DW, Q

CONNECTION DIAGRAMS

DIL-20, SOIC-20 (Top View)
 J or N Package, DW Package

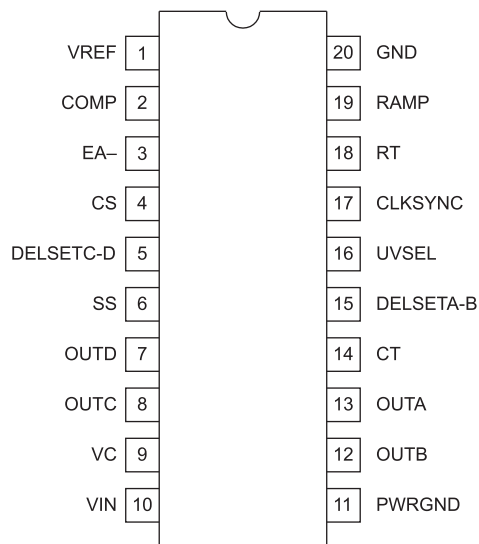

CLCC-28 (Top View)
 L Package

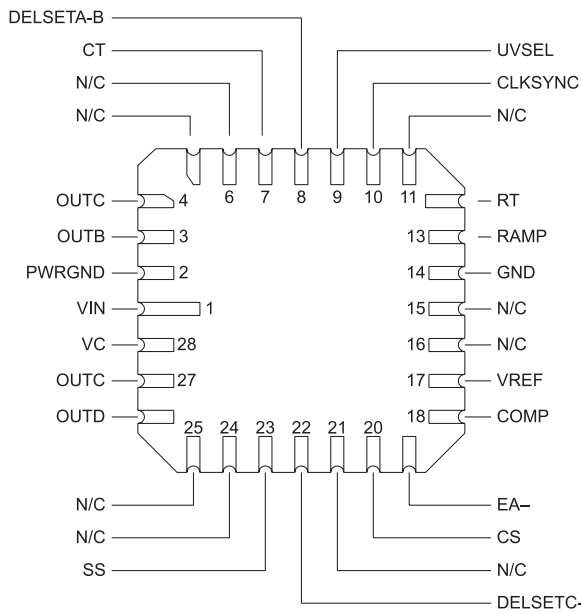

PLCC-20 (Top View)
 Q Package

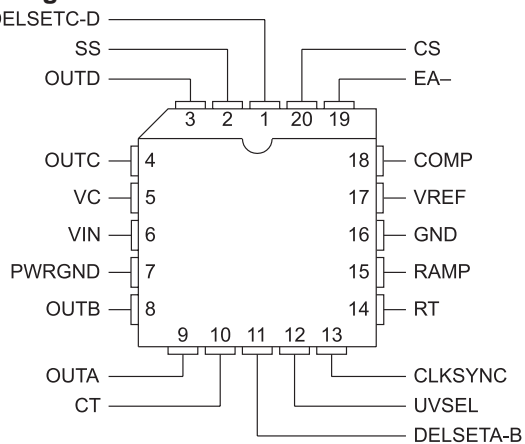

ELECTRICAL CHARACTERISTICS Unless specified; $V_C = V_{IN} = V_{UVSEL} = 12V$, $C_T = 470pF$, $R_T = 9.53k$, $R_{DELSETA-B} = R_{DELSEC-D} = 4.8k$, $C_{DELSETA-B} = C_{DELSETC-D} = 0.01\mu F$, $T_A = T_J$.

PARAMETER	TEST CONDITIONS	MIN	TYP	MAX	UNITS
Undervoltage Lockout					
Start Threshold	$V_{UVSEL} = V_{IN}$	9	10.75	12.5	V
	$V_{UVSEL} = \text{Open}$	12.5	15.25	16.5	V
UVLO Hysteresis	$V_{UVSEL} = V_{IN}$	1.15	1.75	2.15	V
	$V_{UVSEL} = \text{Open}$	5.2	6	7.4	V
Input Bias, UVSEL Pin	$V_{UVSEL} = V_{IN} = 8V$		30		μA
Supply Current					
I_{VIN} Startup	$V_{IN} = V_{UVSEL} = 8V$, $V_C = 18V$, $I_{DELSETA-B} = I_{DELSETC-D} = 0$		150	600	μA
I_{VC} Startup	$V_{IN} = V_{UVSEL} = 8V$, $V_C = 18V$, $I_{DELSETA-B} = I_{DELSETC-D} = 0$		10	100	μA
I_{VIN} Operating	UC3879, UC2879		23	33	mA
	UC1879		23	36	mA
I_{VC} Operating			4	8	mA
Voltage Reference					
Output Voltage	$T_J = +25^\circ C$	4.92	5	5.08	V
Line Regulation	$11V < V_{IN} < 18V$		1	10	mV
Load Regulation	$I_{VREF} = -10mA$		5	20	mV
Total Variation	Line, Load, Temperature	4.875		5.125	V
Short Circuit Current	$V_{REF} = 0V$, $T_J = 25^\circ C$		-60	-15	mA
Error Amplifier					
Error Amplifier Input Voltage		2.4	2.5	2.6	V
Input Bias Current			0.6	3	μA
AVOL	$1V < V_{COMP} < 4V$	60	90		dB
PSRR	$11V < V_{IN} < 18V$	85	100		dB
Output Sink Current	$V_{COMP} = 1V$	1	2.5		mA
Output Source Current	$V_{COMP} = 4V$		-1.3	-0.5	mA
Output Voltage High	$I_{COMP} = -0.5mA$	4	4.7	5	V
Output Voltage Low	$I_{COMP} = 1mA$	0	0.5	1	V
Slew Rate	$T_A = +25^\circ C$	6	11		V/ μs
PWM Comparator					
RAMP Offset Voltage	$T_J = 25^\circ C$, Note 3	1.1	1.25	1.4	V
PWM Phase Shift, $T_{DELSETA-B}$, $T_{DELSETC-D} = 0$, Note 1	$V_{COMP} > V_{RAMPpeak} + V_{RAMPoffset}$	98	99.7	102	%
	$V_{COMP} < \text{Zero Phase Shift Voltage}$	0	0.3	2	%
Output Skew, $T_{DELSETA-B}$, $T_{DELSETC-D} = 0$, Note 1	$V_{COMP} > V_{RAMPpeak} + V_{RAMPoffset}$		10		ns
	$V_{COMP} < \text{Zero Phase Shift Voltage}$		10		ns
Ramp to Output Delay, $T_{DELSETA-B} = 0$, $T_{DELSETC-D} = 0$	UC3879, UC2879		115	250	ns
	UC1879		115	300	ns
Oscillator					
Initial Accuracy	$T_A = 25^\circ C$	180	200	220	kHz
Voltage Stability	$11V < V_{IN} < 18V$		1	2	%
Total Variation	Line, Temperature	160	200	240	kHz
CLKSYNC Threshold		2.3	2.5	2.7	V
Clock Out High		2.8	4		V
Clock Out Low		0.5	1	1.5	V
Clock Out Pulse Width			400	600	ns
Ramp Valley Voltage			0.2	0.4	V

ELECTRICAL CHARACTERISTICS Unless specified; VC = VIN = VUVSEL = 12V, CT = 470pF, RT = 9.53k, RDELSETA-B = RDELSEC-D = 4.8k, CDELSETA-B = CDELSETC-D = 0.01μF, TA = TJ.

PARAMETER	TEST CONDITIONS	MIN	TYP	MAX	UNITS
Ramp Peak Voltage		2.8	2.9	3.2	V
Current Limit					
Input Bias	V _{CS} = 3.0V		2	10	μA
Threshold Voltage		2.35	2.5	2.65	V
Delay to OUTA, B, C, D			160	300	ns
Cycle-by-Cycle Current Limit					
Input Bias	V _{CS} = 2.2V		2	10	μA
Threshold Voltage		1.85	2	2.15	V
Delay to Output Zero Phase			110	300	ns
Soft Start/Reset Delay					
Charge Current	V _{SS} = 0.5V	-20	-9	-3	μA
Discharge Current	V _{SS} = 1V	120	230		μA
Restart Threshold		4.3	4.7		V
Discharge Level			300		mV
Output Drivers					
Output Low Level	I _{OUT} = 10mA		0.3	0.4	V
Output High Level	I _{OUT} = -10mA, Referenced to VC		2.2	3	V
Delay Set (Note 5)					
Delay Time	R _{DELSETA-B} = R _{DELSETC-D} = 4.8k	300	430	600	ns
Delay Time	R _{DELSETA-B} = R _{DELSETC-D} = 1.9k	130	170	250	ns
Zero Delay	V _{DELSETA-B} = V _{DELSETC-D} = 5V		5		ns

Note 1. Phase shift percentage (0% = 0°, 100% = 180°) is defined as $\theta = \frac{200}{T} \Phi$ %

where θ is the phase shift, and Φ and T are defined in Figure 1. At 0% phase shift, Φ is the output skew.

Note 2. Delay time is defined as:

$$\text{delay} = T \cdot \left(\frac{1}{2} - \text{duty cycle} \right)$$

where T is defined in Figure 1.

Note 3. Ramp offset voltage has a temperature coefficient of about -4mV/°C.

Note 4. The zero phase shift voltage is the voltage measured at COMP which forces zero phase shift. This condition corresponds to zero effective output power. Zero phase shift voltage has a temperature coefficient of about -2mV/°C.

Note 5. Delay time can be programmed via resistors from the delay set pins to ground.

$$\text{Delay Time} = \left(0.89 \cdot 10^{-10} \cdot R_{\text{DELAY}} \right) \text{sec}$$

The recommended range for R_{DELAY} is 1.9k to 10k.

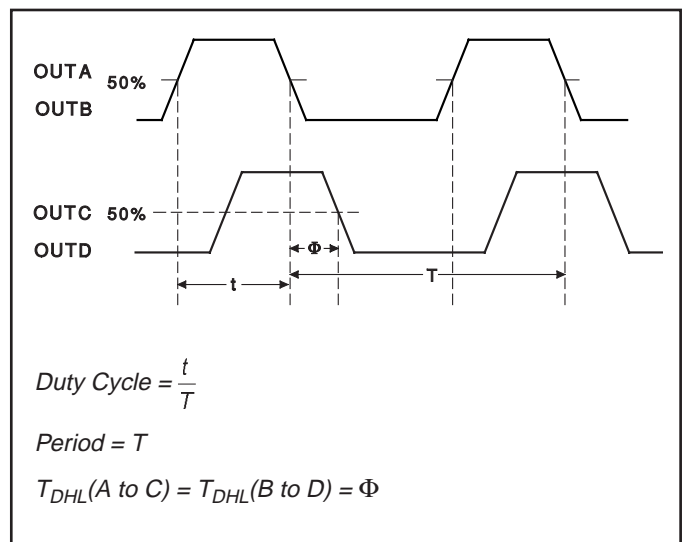

Figure 1. Phase Shift, Output Skew & Delay Time Definitions

PIN DESCRIPTIONS

CLKSYNC (Bi-directional Clock and Synchronization): Used as an output, CLKSNC provides a clock signal. As an input, this pin provides a synchronization point. Multiple UC3879s, each with their own local oscillator frequency, may be connected together by the CLKSNC pin, and they will synchronize to the fastest oscillator. This pin may also be used to synchronize the UC3879 to an external clock, provided the frequency of the external signal is higher than the frequency of the local oscillator. CLKSNC is internally connected to an emitter follower pull-up and a current source pull-down (300µA typical). Therefore an external resistor to GND can be used to improve the CLKSNC pin's ability to drive capacitive loads.

COMP (Error Amplifier Output): This pin is the output of the gain stage for overall feedback control. Error amplifier output voltage levels below 0.9 volt forces zero phase shift. Since the error amplifier has a relatively low current drive capability, the output may be overridden by driving it with a sufficiently low impedance source.

CT (Oscillator Frequency Set): After choosing R_T to set the required upper end of the linear duty cycle range, the timing capacitor (CT) value is calculated to set the oscillator frequency as follows:

$$CT = \frac{D_{lin}}{1.08 \bullet RT \bullet f}$$

Connect the timing capacitor directly between CT and GND. Use a high quality ceramic capacitor with low ESL and ESR for best results. A minimum CT value of 200pF insures good accuracy and less susceptibility to circuit layout parasitics. The oscillator and PWM are designed to provide practical operation to 600kHz.

CS (Current Sense): This pin is the non-inverting input to the two current fault comparators whose references are set internally to fixed values of 2.0V and 2.5V. When the voltage at this pin exceeds 2.0V, and the error amplifier output voltage exceeds the voltage on the ramp input, the phase shift limiting overcurrent comparator will limit the phase shifting on a cycle-by-cycle basis. When the voltage at this pin exceeds 2.5V, the current fault latch is set, the outputs are forced OFF, and a soft start cycle is initiated. If a constant voltage above 2.5V is applied to this pin the outputs are disabled and held low. When CS is brought below 2.5V, the outputs will begin switching at 0 degrees phase shift before the SS pin begins to rise. This condition will not prematurely deliver power to the load.

DELSETA-B, DELSETC-D (Output Delay Control): The user programmed currents from these pins to GND set the turn on delay for the corresponding output pair. This delay is introduced between the turn off of one switch and the turn on of another in the same leg of the bridge to allow resonant switching to take place. Separate delays are provided for the two half-bridges to accommodate differences in the resonant capacitor charging currents.

EA- (Error Amplifier Inverting Input): This is normally connected to the voltage divider resistors which sense the power supply output voltage level. The loop compensation components are connected between this pin and COMP.

GND (Signal Ground): All voltages are measured with respect to GND. The timing capacitor on CT, and bypass capacitors on VREF and VIN should be connected directly to the ground plane near GND.

OUTA – OUTD (Outputs A-D): The outputs are 100mA totem pole output drivers optimized to drive FET driver ICs. The outputs operate as pairs with a nominal 50% duty cycle. The A-B pair is intended to drive one half-bridge in the external power stage and is synchronized to the clock waveform. The C-D pair drives the other half-bridge with switching phase shifted with respect to the A-B outputs.

PWRGND (Power Ground): VC should be bypassed with a ceramic capacitor from VC to the section of the ground plane that is connected to PWRGND. Any required bulk reservoir capacitor should be connected in parallel. PWRGND and GND should be connected at a single point near the chip to optimize noise rejection and minimize DC voltage drops.

RAMP (Voltage Ramp): This pin is the input to the PWM comparator. Connect it to CT for voltage mode control. For current mode control, connect RAMP to CS and also to the output of the current sense transformer circuit. Slope compensation can be achieved by injecting a portion of the ramp voltage from CT to RAMP.

PIN DESCRIPTIONS (cont.)

RT (Clock/Sync Duty Cycle Set Pin): The UC3879 oscillator produces a sawtooth waveform. The rising edge is generated by connecting a resistor from RT to GND and a capacitor from CT to GND (see CT pin description). During the rising edge, the modulator has linear control of the duty cycle. The duty cycle jumps to 100% when the voltage on COMP exceeds the oscillator peak voltage. Selection of RT should be done first, based on the required upper end of the linear duty cycle range (D_{lin}) as follows:

$$RT = \frac{2.5}{10mA \cdot (1 - D_{lin})}$$

Recommended values for RT range from 2.5k to 100k.

SS: Connect a capacitor between this pin and GND to set the soft start time. The voltage at SS will remain near zero volts as long as VIN is below the UVLO threshold. Soft start will be pulled up to about 4.8V by an internal 9μA current source when VIN and VREF become valid (assuming a non-fault condition). In the event of a current fault (CS voltage exceeding 2.5V), soft start will be pulled to GND and then ramp to 4.8V. If a fault occurs during the soft start cycle, the outputs will be immediately disabled and soft start must fully charge prior to resetting the fault latch. For paralleled controllers, the soft start pins may be paralleled to a single capacitor, but the charge currents will be additive.

ADDITIONAL INFORMATION

Please refer to the following Unitrode publications for additional information. The following three topics are available in the Applications Handbook.

[1] Application Note U-154, *The New UC3879 Phase-Shifted PWM Controller Simplifies the Design of Zero Voltage Transition Full-Bridge Converters* by Laszlo Balogh.

UVSEL: Connecting this pin to VIN sets a turn on voltage of 10.75V with 1.5V of UVLO hysteresis. Leaving the pin open-circuited programs a turn on voltage of 15.25V with 6.0V of hysteresis.

VC (Output Switch Supply Voltage): This pin supplies power to the output drivers and their associated bias circuitry. The difference between the output high drive and VC is typically 2.1V. This supply should be bypassed directly to PWRGND with a low ESR/ESL capacitor.

VIN (Primary Chip Supply Voltage): This pin supplies power to the logic and analog circuitry on the integrated circuit that is not directly associated with driving the output stages. Connect VIN to a stable source above 12V for normal operation. To ensure proper functionality, the UC3879 is inactive until VIN exceeds the upper undervoltage lockout threshold. This pin should be bypassed directly to GND with a low ESR/ESL capacitor.

NOTE: When VIN exceeds the UVLO threshold the supply current (I_{IN}) jumps from about 100μA to greater than 20mA. If the UC3879 is not connected to a well bypassed supply, it may immediately enter the UVLO state again. Therefore, sufficient bypass capacity must be added to ensure reliable startup.

VREF: This pin provides an accurate 5V voltage reference. It is internally short circuit current limited. VREF is disabled while VIN is below the UVLO threshold. The circuit is also disabled until VREF reaches approximately 4.75V. For best results bypass VREF with a 0.1μF, low ESR/ESL capacitor.

[2] Application Note U-136, *Phase Shifted, Zero Voltage Transition Design Considerations and the UC3875 PWM Controller* by Bill Andreyck.

Design Note DN-63, *The Current-Doubler Rectifier: An Alternative Rectification Technique for Push-Pull and Bridge Converters* by Laszlo Balogh.

IMPORTANT NOTICE

Texas Instruments and its subsidiaries (TI) reserve the right to make changes to their products or to discontinue any product or service without notice, and advise customers to obtain the latest version of relevant information to verify, before placing orders, that information being relied on is current and complete. All products are sold subject to the terms and conditions of sale supplied at the time of order acknowledgement, including those pertaining to warranty, patent infringement, and limitation of liability.

TI warrants performance of its semiconductor products to the specifications applicable at the time of sale in accordance with TI's standard warranty. Testing and other quality control techniques are utilized to the extent TI deems necessary to support this warranty. Specific testing of all parameters of each device is not necessarily performed, except those mandated by government requirements.

CERTAIN APPLICATIONS USING SEMICONDUCTOR PRODUCTS MAY INVOLVE POTENTIAL RISKS OF DEATH, PERSONAL INJURY, OR SEVERE PROPERTY OR ENVIRONMENTAL DAMAGE ("CRITICAL APPLICATIONS"). TI SEMICONDUCTOR PRODUCTS ARE NOT DESIGNED, AUTHORIZED, OR WARRANTED TO BE SUITABLE FOR USE IN LIFE-SUPPORT DEVICES OR SYSTEMS OR OTHER CRITICAL APPLICATIONS. INCLUSION OF TI PRODUCTS IN SUCH APPLICATIONS IS UNDERSTOOD TO BE FULLY AT THE CUSTOMER'S RISK.

In order to minimize risks associated with the customer's applications, adequate design and operating safeguards must be provided by the customer to minimize inherent or procedural hazards.

TI assumes no liability for applications assistance or customer product design. TI does not warrant or represent that any license, either express or implied, is granted under any patent right, copyright, mask work right, or other intellectual property right of TI covering or relating to any combination, machine, or process in which such semiconductor products or services might be or are used. TI's publication of information regarding any third party's products or services does not constitute TI's approval, warranty or endorsement thereof.

Copyright © 1999, Texas Instruments Incorporated