

IN74LV04

HEX INVERTER

The IN74LV04 is a low-voltage Si-gate CMOS device that is pin and function compatible with 74HC/HCT04A.

The IN74LV04 provides six inverting buffers.

- Wide Operating Voltage: 1.0÷5.5 V
- Optimized for Low Voltage applications: 1.0÷3.6 V
- Accepts TTL input levels between $V_{CC} = 2.7$ V and $V_{CC} = 3.6$ V
- Low Input Current

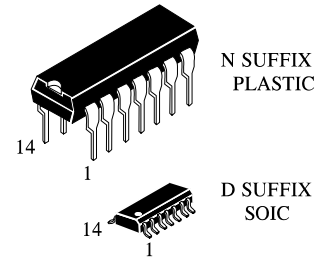

ORDERING INFORMATION

IN74LV04N	Plastic
IN74LV04D	SOIC
IZ74LV04	Chip

$T_A = -40^\circ \div 125^\circ$ C for all packages

LOGIC DIAGRAM

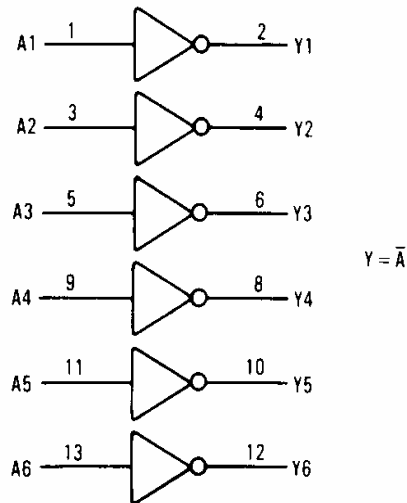

PIN 14 = V_{CC}
PIN 7 = GND

PIN ASSIGNMENT

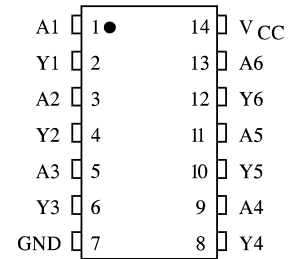

FUNCTION TABLE

Input	Output
A	Y
L	H
H	L

IN74LV04

MAXIMUM RATINGS*

Symbol	Parameter	Value	Unit
V_{CC}	DC supply voltage (Referenced to GND)	-0.5 ÷ +7.0	V
I_{IK}^{*1}	DC input diode current	±20	mA
I_{OK}^{*2}	DC output diode current	±50	mA
I_O^{*3}	DC output source or sink current - bus driver outputs	±25	mA
I_{GND}	DC GND current for types with - bus driver outputs	±50	mA
I_{CC}	DC V_{CC} current for types with - bus driver outputs	±50	mA
P_D	Power dissipation per package, plastic DIP+ SOIC package+	750 500	mW
T_{stg}	Storage temperature	-65 ÷ +150	°C
T_L	Lead temperature, 1.5 mm from Case for 10 seconds (Plastic DIP), 0.3 mm (SOIC Package)	260	°C

Maximum Ratings are those values beyond which damage to the device may occur. Functional operation should be restricted to the Recommended Operating Conditions.

+Derating - Plastic DIP: - 12 mW/°C from 70° to 125°C

SOIC Package: - 8 mW/°C from 70° to 125°C

*1: $V_I < -0.5V$ or $V_I > V_{CC} + 0.5V$

*2: $V_O < -0.5V$ or $V_O > V_{CC} + 0.5V$

*3: $-0.5V < V_O < V_{CC} + 0.5V$

RECOMMENDED OPERATING CONDITIONS

Symbol	Parameter	Min	Max	Unit
V_{CC}	DC Supply Voltage (Referenced to GND)	1.0	5.5	V
V_{IN}, V_{OUT}	DC Input Voltage, Output Voltage (Referenced to GND)	0	V_{CC}	V
T_A	Operating Temperature, All Package Types	-40	+125	°C
t_r, t_f	Input Rise and Fall Time			ns
	$V_{CC} = 1.2$ V	0	1000	
	$V_{CC} = 2.0$ V	0	700	
	$V_{CC} = 3.0$ V	0	500	
	$V_{CC} = 3.6$ V	0	400	

This device contains protection circuitry to guard against damage due to high static voltages or electric fields. However, precautions must be taken to avoid applications of any voltage higher than maximum rated voltages to this high-impedance circuit. For proper operation, V_{IN} and V_{OUT} should be constrained to the range $GND \leq (V_{IN} \text{ or } V_{OUT}) \leq V_{CC}$.

Unused inputs must always be tied to an appropriate logic voltage level (e.g., either GND or V_{CC}). Unused outputs must be left open.

IN74LV04

DC ELECTRICAL CHARACTERISTICS (Voltages Referenced to GND)

Symbol	Parameter	Test Conditions	V _{CC} , V	Guaranteed Limit						Unit
				25°C		-40°C ÷ 85°C		-40°C ÷ 125°C		
				min	max	min	max	min	max	
V _{IH}	High-Level Input Voltage		1.2	0.9	-	0.9	-	0.9	-	V
			2.0	1.4	-	1.4	-	1.4	-	
			3.0	2.1	-	2.1	-	2.1	-	
			3.6	2.5	-	2.5	-	2.5	-	
V _{IL}	Low-Level Input Voltage		1.2	-	0.3	-	0.3	-	0.3	V
			2.0	-	0.6	-	0.6	-	0.6	
			3.0	-	0.9	-	0.9	-	0.9	
			3.6	-	1.1	-	1.1	-	1.1	
V _{OH}	High-Level Output Voltage	V _I = V _{IL} I _O = -50 μA	1.2	1.1	-	1.0	-	1.0	-	V
			2.0	1.92	-	1.9	-	1.9	-	
		*	2.92	-	2.9	-	2.9	-		
		V _I = V _{IL} I _O = -6.0 μA	*	2.48	-	2.34	-	2.20	-	V
V _{OL}	Low-Level Output Voltage	V _I = V _{IH} I _O = 50 μA	1.2	-	0.09	-	0.1	-	0.1	V
			2.0	-	0.09	-	0.1	-	0.1	
				V _I = V _{IH} or V _{IL} I _O = 6.0 mA	3.0	-	0.33	-	0.4	-
I _{IL}	Low-Level Input Leakage Current			-	-0.1	-	-1.0	-	-1.0	μA
I _{IH}	High-Level Input Leakage Current	V _I = V _{CC}	*	-	0.1	-	1.0	-	1.0	μA
I _{CC}	Quiescent Supply Current (per Package)	V _I = 0 B or V _{CC} I _O = 0 μA	*	-	2.0	-	20	-	40	μA

* : V_{CC} = (3.3±0.3) V

IN74LV04

AC ELECTRICAL CHARACTERISTICS ($C_L=50$ pF, $t_{LH} = t_{HL} = 6.0$ ns, $V_{IL}=0V$, $V_{IH}=V_{CC}$, $R_L=1$ k Ω)

Symbol	Parameter	V_{CC} V	Guaranteed Limit						Unit
			25°C		-40°C ÷ 85°C		-40°C ÷ 125°C		
			min	max	min	max	min	max	
t_{THL} , (t_{TLH})	Output Transition Time, Any Output (Figure 1)	1.2 2.0 *	- 70 10	- 16 10	- 85 13	- 20 13	- 24 15	- 100 15	ns
t_{PHL} , (t_{PLH})	Propagation Delay, Input A to Output Y (Figure 1)	1.2 2.0 *	- 90 14	- 23 14	- 120 18	- 28 18	- 34 21	- 150 21	pF
C_I	Input Capacitance	3.0	-	-	-	3.5	-	3.5	pF

C_{PD}	Power Dissipation Capacitance (Per Inverter)	$T_A=25^\circ C$, $V_I=0V \div V_{CC}$		pF
		42		

Used to determine the no-load dynamic power consumption:
 $P_D = C_{PD}V_{CC}^2f_i + \sum(C_LV_{CC}^2f_o)$, f_i - input frequency, f_o - output frequency (MHz)
 $\sum(C_LV_{CC}^2f_o)$ - sum of the outputs

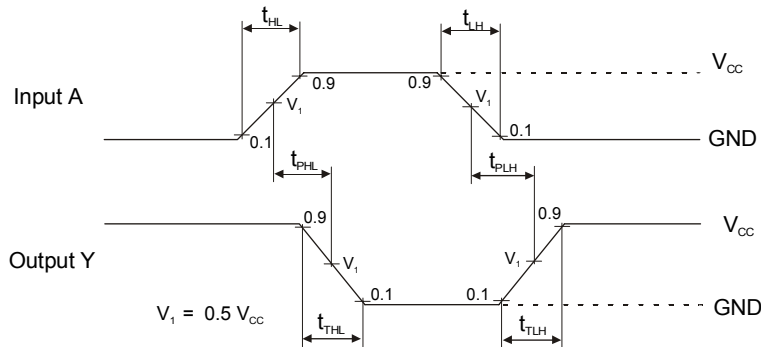

Figure 1. Switching Waveforms

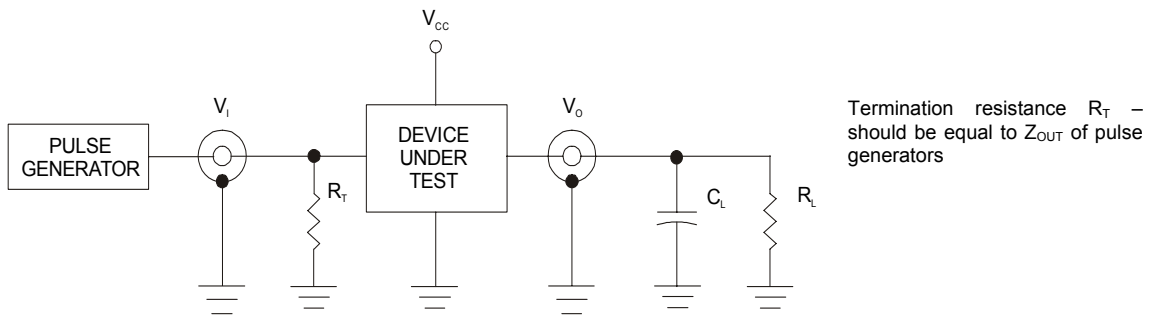
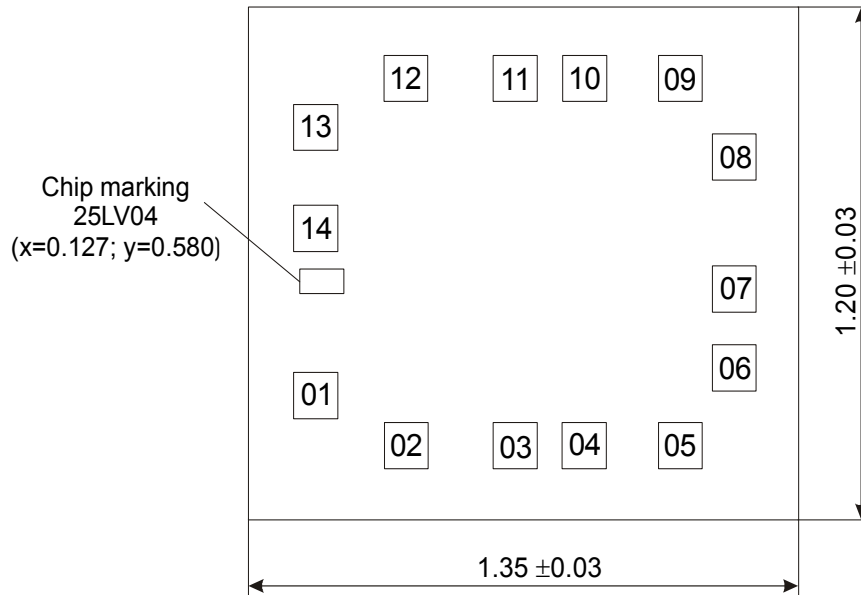

Figure 2. Test Circuit

IN74LV04

CHIP PAD DIAGRAM IZ74LV04



Pad size 0.108 x 0.108 mm (Pad size is given as per metallization layer)
Thickness of chip 0.46 ± 0,02 mm

PAD LOCATION

Pad No	Symbol	X	Y
01	A1	0.111	0.228
02	Y1	0.333	0.111
03	A2	0.600	0.111
04	Y2	0.770	0.111
05	A3	1.006	0.111
06	Y3	1.138	0.293
07	GND	1.138	0.477
08	Y4	1.138	0.786
09	A4	1.006	0.970
10	Y5	0.771	0.970
11	A5	0.600	0.970
12	Y6	0.332	0.970
13	A6	0.111	0.855
14	Vcc	0.111	0.619