

VOLTAGE PROTECTION FOR 2-, 3-, OR 4-CELL Lion BATTERIES (2nd PROTECTION)

FEATURES

- 2-, 3-, or 4-Cell Secondary Protection
- Low Power Consumption $I_{CC} < 2 \mu\text{A}$ [$V_{CELL(ALL)} < V_{(PROTECT)}$]
- High Accuracy Over Sense Voltage:
 - bq29400: 4.35 V \pm 25 mV
 - bq29400A: 4.40 V \pm 25 mV
 - bq29401: 4.45 V \pm 25 mV
 - bq29405: 4.65 V \pm 25 mV
- Prefixed Protection Threshold Voltage
- Programmable Delay Time
- High Power Supply Ripple Rejection
- Stable During Pulse Charge Operation

APPLICATIONS

- 2nd Level Protection in Lion Battery Packs in
 - Notebook PCs
 - Portable Instrumentation
 - Medical and Test Equipment

DESCRIPTION

The bq29400, bq29400A, bq29401, and bq29405 are BiCMOS secondary protection ICs for 2-, 3-, or 4-cell Lithium-Ion battery packs that incorporate a high-accuracy precision over voltage detection circuit. They include a programmable delay circuit for over voltage detection time.

FUNCTION

Each cell in a multiple cell pack is compared to an internal reference voltage. If one cell reaches an overvoltage condition, the protection sequence begins. The bq2940x device starts charging an external capacitor through the CD pin. When the CD pin voltage reaches 1.2 V, the OUT pin changes from a low level to a high level.

**PW PACKAGE
(TOP VIEW)**



**DCT PACKAGE
(TOP VIEW)**

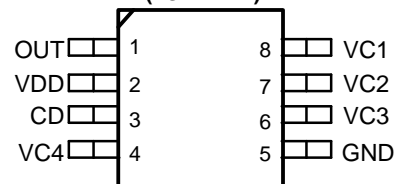

ORDERING INFORMATION

T _A	V _(PROTECT)	PACKAGE			
		MSSOP (DCT3)	SYMBOL	TSSOP (PW) ⁽¹⁾	SYMBOL
–25°C to 85°C	4.35 V	bq29400DCT3	CIQ	bq29400PW	2400
	4.40 V	bq29400ADCT3	CIT	Not Available	-
	4.45 V	bq29401DCT3	CIR	bq29401PW	2401
	4.65 V	bq29405DCT3	CIS	Not Available	-

(1) The bq29400, bq29400A, bq29401, and bq29405 are available taped and reeled. Add an R suffix to the device type (e.g., bq29400PWR) to order tape and reel version.



Please be aware that an important notice concerning availability, standard warranty, and use in critical applications of Texas Instruments semiconductor products and disclaimers thereto appears at the end of this data sheet.



These devices have limited built-in ESD protection. The leads should be shorted together or the device placed in conductive foam during storage or handling to prevent electrostatic damage to the MOS gates.

ABSOLUTE MAXIMUM RATINGS

over operating free-air temperature range unless otherwise noted⁽¹⁾⁽²⁾

		UNIT
Supply voltage range	(VDD)	–0.3 V to 28 V
Input voltage range	(VC1, VC2, VC3, VC4)	–0.3 V to 28 V
Output voltage range	(OUT)	–0.3 V to 28 V
	(CD)	–0.3 V to 28 V
Continuous total power dissipation		See Dissipation Rating Table
Storage temperature range, T _{stg}		–65°C to 150°C
Lead temperature (soldering, 10 sec)		300°C

- Stresses beyond those listed under "absolute maximum ratings" may cause permanent damage to the device. These are stress ratings only, and functional operation of the device at these or any other conditions beyond those indicated under "recommended operating conditions" is not implied. Exposure to absolute-maximum-rated conditions for extended periods may affect device reliability.
- All voltages are with respect to ground of this device except the differential voltage of VC1-VC2, VC2-VC3, VC3-VC4 and VC4-GND.

PACKAGE DISSIPATION RATINGS

PACKAGE	T _A = 25°C POWER RATING	DERATING FACTOR ABOVE T _A = 25°C	T _A = 70°C POWER RATING	T _A = 85°C POWER RATING
DCT	412 mW	3.3 mW/°C	264 mW	214 mW
PW	525 mW	4.2 mW/°C	336 mW	273 mW

RECOMMENDED OPERATING CONDITIONS

		MIN	NOM	MAX	UNIT
V _{DD}	Supply Voltage	4.0		25	V
V _I	Input voltage range	0		V _{DD} +0.3	V
t _{d(CD)}	Delay time capacitance		0.22		μF
R _{IN}	Voltage-monitor filter resistance	100	1k		Ω
C _{IN}	Voltage-monitor filter capacitance	0.01	0.1		μF
R _{VD}	Supply-voltage filter resistance	0		1	kΩ
C _{VD}	Supply-voltage filter capacitance		0.1		μF
T _A	Operating ambient temperature range	–25		85	°C

ELECTRICAL CHARACTERISTICS

over recommended operating free-air temperature range, $T_A = 25^\circ\text{C}$ (unless otherwise noted)⁽¹⁾

PARAMETER		TEST CONDITION	MIN	NOM	MAX	UNIT
$V_{(OA)}$	Over voltage detection accuracy			25	35	mV
		$T_A = -20^\circ\text{C}$ to 85°C		25	50	
$V_{(PROTECT)}$	Over voltage detection voltage ⁽¹⁾	bq29400		4.35		V
		bq2940A		4.40		
		bq29401		4.45		
		bq29405		4.65		
V_{hys}	Over voltage detection hysteresis ⁽¹⁾			300		mV
I_I	Input current	$V_2, V_3, VC4$ input = $VC1-VC2 = VC2-VC3 = VC3-VC4 = VC4-GND = 3.5$ V			0.3	μA
t_{D1}	Over voltage detection delay time	$CD = 0.22$ μF	1.0	1.5	2.0	S
$I_{(CD_dis)}$	CD GND clamp current	$CD = 1$ V	5	12		μA
I_{CC}	Supply current	$VC1-VC2 = VC2-VC3 = VC3-VC4 = VC4-GND = 3.5$ V (see Figure 1)		2.0	3.0	μA
		$VC1 = VC2 = VC3 = VC4 = VC3-VC4 = VC4-GND = 2.3$ V (see Figure 1)		1.5	2.5	
$V_{(OUT)}$	OUT pin drive voltage	$VC1-VC2 = VC2-VC3 = VC3-VC4 = VC4-GND = V_{(PROTECT)MAX}$, $VDD = VC1$, $I_{OH} = 0$ mA		7		V
		$VC1=VC2=VC3=VC4=V_{(PROTECT)MAX}$, $VDD=4.3V$, $T_A=0^\circ\text{C}$ to 70°C , $I_{OH} = -40\mu\text{A}$		1.5	2.0	2.5
I_{OH}	High-level output current	$OUT = 3V$, $VC1-VC2 = VC2-VC3 = VC3-VC4 = VC4-GND = 4.7$ V	-1			mA
I_{OL}	Low-level output current	$OUT = 0.1$ V $VC1-VC2 = VC2-VC3 = VC3-VC4 = VC4-GND = 3.5$ V	5			μA

(1) Levels of the over-voltage detection and the hysteresis can be adjusted. For assistance contact Texas Instruments sales representative.

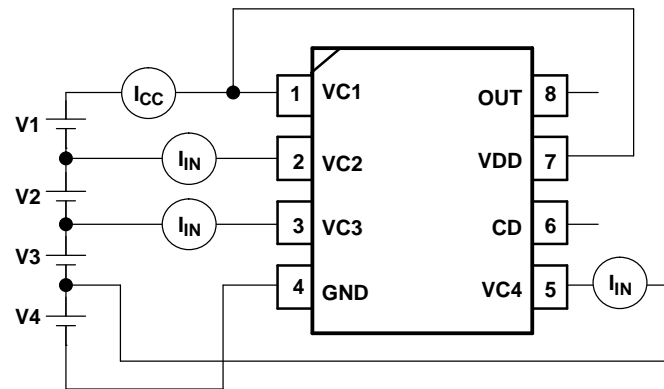

Figure 1. I_{CC} , I_{IN} Measurement (TSSOP Package)

Terminal Functions

TERMINAL			DESCRIPTION
MSOP (DTC)	TSSOP (PW)	NAME	
8	1	VC1	Sense voltage input for most positive cell
7	2	VC2	Sense voltage input for second most positive cell
6	3	VC3	Sense voltage input for third most positive cell
5	4	GND	Ground pin
4	5	VC4	Sense voltage input for least positive cell

Terminal Functions (continued)

TERMINAL			DESCRIPTION
MSOP (DTC)	TSSOP (PW)	NAME	
3	6	CD	An external capacitor is connected to determine the programmable delay time
2	7	VDD	Power supply
1	8	OUT	Output

FUNCTIONAL BLOCK DIAGRAM

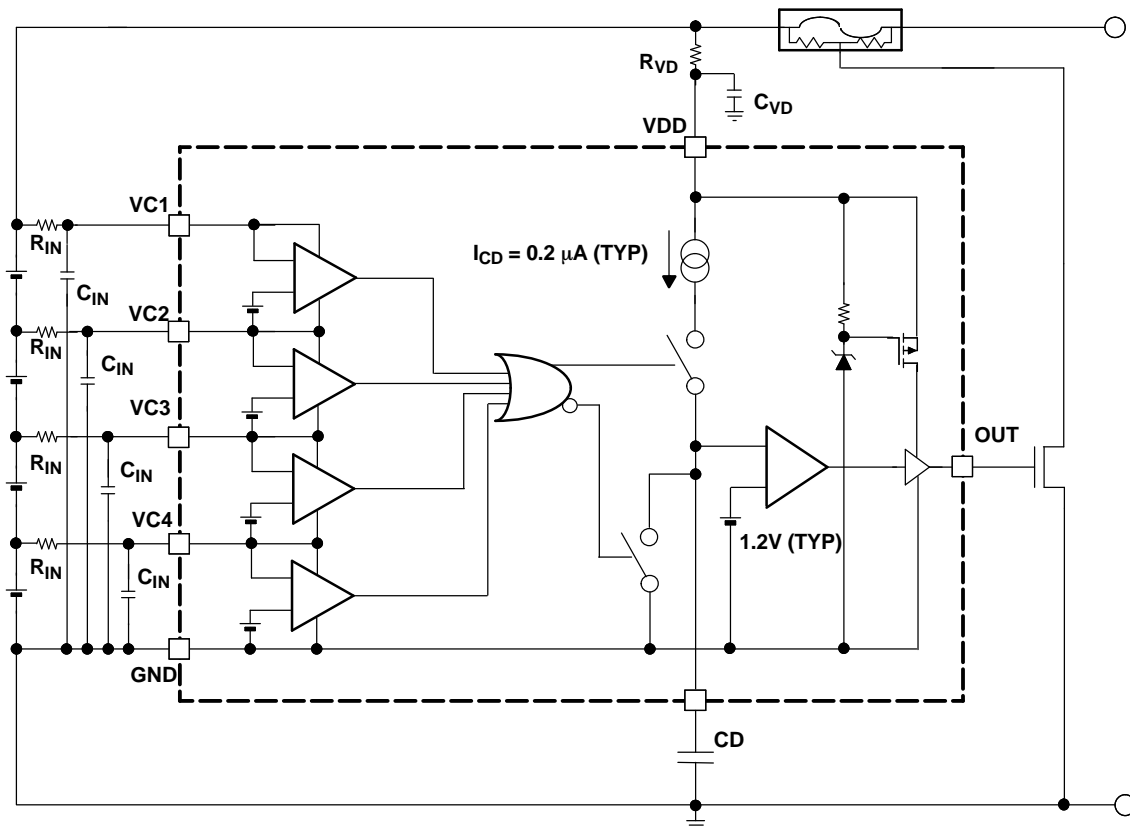

OVERVOLTAGE PROTECTION

When one of the cell voltages exceeds $V_{(PROTECT)}$, an internal current source begins to charge the capacitor, $C_{(DELAY)}$, connected to the CD pin. If the voltage at the CD pin, V_{CD} , reaches 1.2 V, the OUT pin is activated and transitions high. An externally connected NCH FET is activated and blows the external fuse in the positive battery rail, see Figure 1.

If all cell voltages fall below $V_{(PROTECT)}$ before the voltage at pin CD reaches 1.2 V, the delay time does not run out. An internal switch clamps the CD pin to GND and discharges the capacitor, $C_{(DELAY)}$, and secures the full delay time for the next occurring overvoltage event.

Once the pin OUT is activated, it transitions back from high to low after all battery cells reach $V_{(PROTECT)} - V_{hys}$.

DELAY TIME CALCULATION

The delay time is calculated as follows:

$$t_d = \frac{1.2 \text{ V} \times C_{(\text{DELAY})}}{I_{\text{CD}}}$$

$$C_{(\text{DELAY})} = \frac{t_d \times I_{\text{CD}}}{1.2 \text{ V}}$$

Where $I_{(\text{CD})}$ = CD current source = 0.2 μA

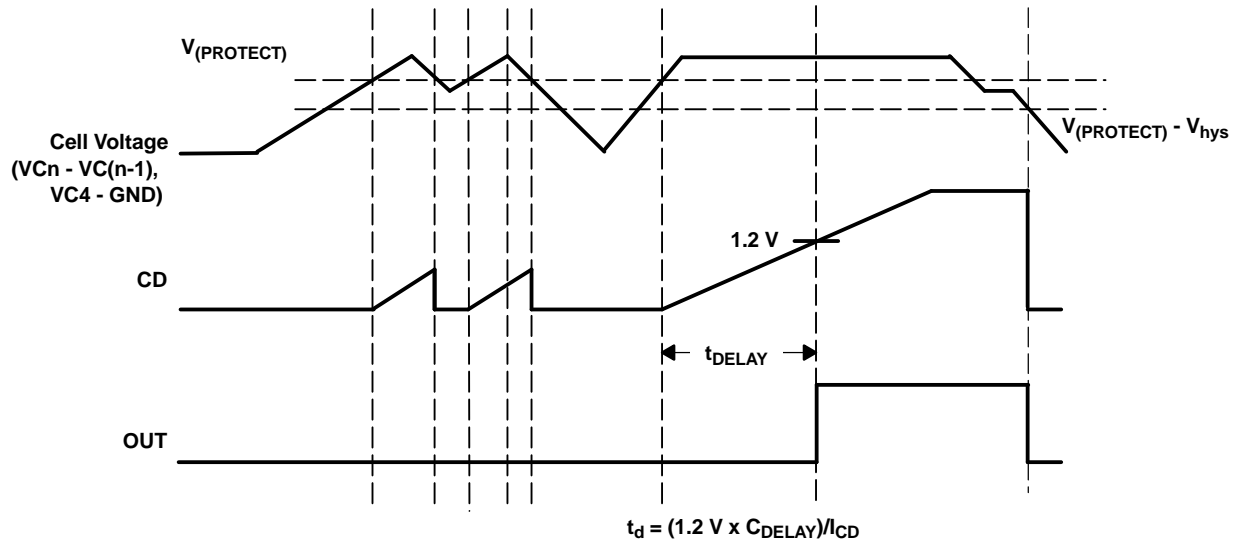
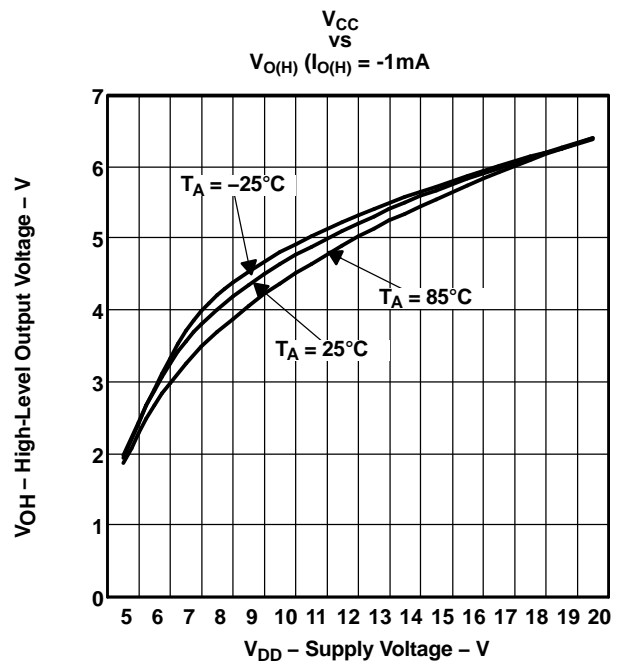
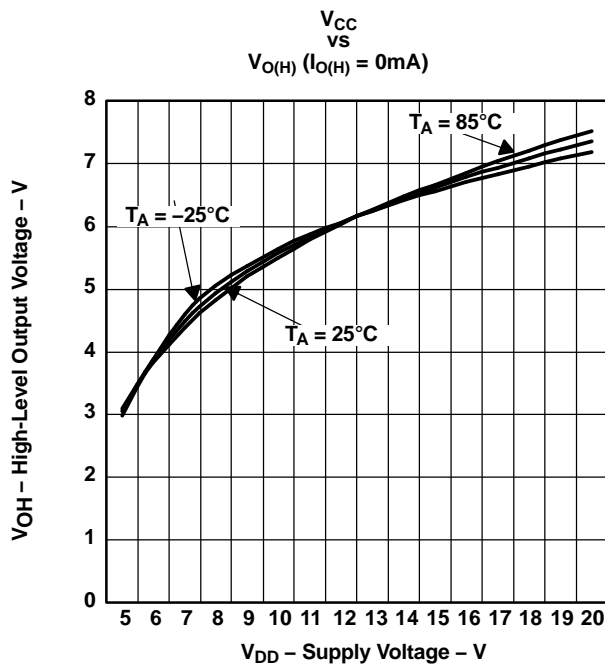

Figure 2. Timing for Overvoltage Sensing



APPLICATION INFORMATION

BATTERY CONNECTIONS

The following diagrams show the TSSOP package device in different cell configurations.

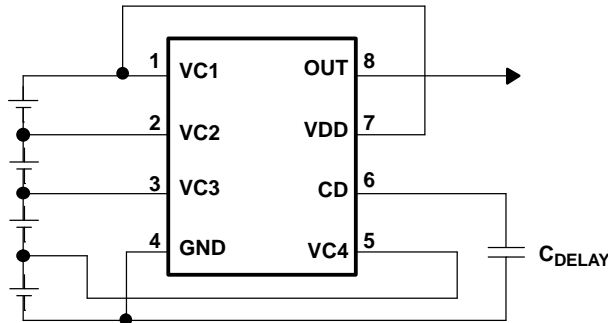

Figure 5. 4-Series Cell Configuration

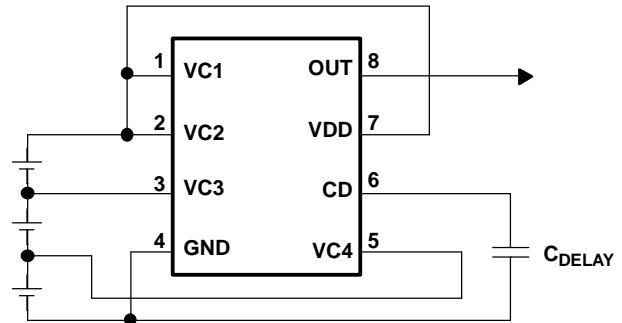

Figure 6. 3-Series Cell Configuration
(Connect together VC1 and VC2)

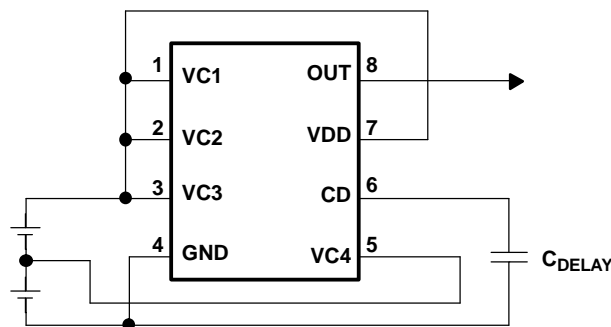

Figure 7. 2-Series Cell Configuration

CELL CONNECTIONS

To prevent incorrect output activation the following connection sequences must be used.

4-Series Cell Configuration

- VC1(=VDD) → VC2 → VC3 → VC4 → GND or
- GND → VC4 → VC3 → VC2 → VC1(=VDD)

3-Series Cell Configuration

- VC1(=VC2=VDD) → VC3 → VC4 → GND or
- GND → VC4 → VC3 → VC1(=VC2=VDD)

2-Series Cell Configuration

- VC1(=VC2=VC3=VDD) → VC4 → GND or
- GND → VC4 → VC1(=VC2=VC3=VDD)

PACKAGING INFORMATION

Orderable Device	Status ⁽¹⁾	Package Type	Package Drawing	Pins	Package Qty	Eco Plan ⁽²⁾	Lead/ Ball Finish	MSL Peak Temp ⁽³⁾	Samples (Requires Login)
BQ29400ADCT3	ACTIVE	SM8	DCT	8	3000	Pb-Free (RoHS)	CU SNBI	Level-1-260C-UNLIM	
BQ29400ADCT3E6	ACTIVE	SM8	DCT	8	3000	Pb-Free (RoHS)	CU SNBI	Level-1-260C-UNLIM	
BQ29400ADCT3R	OBSOLETE	SM8	DCT	8		TBD	Call TI	Call TI	
BQ29400DCT3	ACTIVE	SM8	DCT	8	3000	Pb-Free (RoHS)	CU SNBI	Level-1-260C-UNLIM	
BQ29400DCT3E6	ACTIVE	SM8	DCT	8	3000	Pb-Free (RoHS)	CU SNBI	Level-1-260C-UNLIM	
BQ29400PW	ACTIVE	TSSOP	PW	8	150	Green (RoHS & no Sb/Br)	CU NIPDAU	Level-1-260C-UNLIM	
BQ29400PWR	ACTIVE	TSSOP	PW	8	2000	Green (RoHS & no Sb/Br)	CU NIPDAU	Level-1-260C-UNLIM	
BQ29401DCT	NRND	SM8	DCT	8		TBD	Call TI	Call TI	
BQ29401DCT3	OBSOLETE	SM8	DCT	8		TBD	Call TI	Call TI	
BQ29401DCT3E6	ACTIVE	SM8	DCT	8		TBD	Call TI	Call TI	
BQ29401PW	ACTIVE	TSSOP	PW	8	150	Green (RoHS & no Sb/Br)	CU NIPDAU	Level-1-260C-UNLIM	
BQ29401PWR	ACTIVE	TSSOP	PW	8	2000	Green (RoHS & no Sb/Br)	CU NIPDAU	Level-1-260C-UNLIM	
BQ29405DCT3	ACTIVE	SM8	DCT	8	3000	Pb-Free (RoHS)	CU SNBI	Level-1-260C-UNLIM	
BQ29405DCT3E6	ACTIVE	SM8	DCT	8	3000	Pb-Free (RoHS)	CU SNBI	Level-1-260C-UNLIM	
BQ29405DCT3R	NRND	SM8	DCT	8		TBD	Call TI	Call TI	

⁽¹⁾ The marketing status values are defined as follows:

ACTIVE: Product device recommended for new designs.

LIFEBUY: TI has announced that the device will be discontinued, and a lifetime-buy period is in effect.

NRND: Not recommended for new designs. Device is in production to support existing customers, but TI does not recommend using this part in a new design.

PREVIEW: Device has been announced but is not in production. Samples may or may not be available.

OBSOLETE: TI has discontinued the production of the device.

⁽²⁾ Eco Plan - The planned eco-friendly classification: Pb-Free (RoHS), Pb-Free (RoHS Exempt), or Green (RoHS & no Sb/Br) - please check <http://www.ti.com/productcontent> for the latest availability information and additional product content details.

TBD: The Pb-Free/Green conversion plan has not been defined.

Pb-Free (RoHS): TI's terms "Lead-Free" or "Pb-Free" mean semiconductor products that are compatible with the current RoHS requirements for all 6 substances, including the requirement that lead not exceed 0.1% by weight in homogeneous materials. Where designed to be soldered at high temperatures, TI Pb-Free products are suitable for use in specified lead-free processes.

Pb-Free (RoHS Exempt): This component has a RoHS exemption for either 1) lead-based flip-chip solder bumps used between the die and package, or 2) lead-based die adhesive used between the die and leadframe. The component is otherwise considered Pb-Free (RoHS compatible) as defined above.



www.ti.com

PACKAGE OPTION ADDENDUM

23-Oct-2012

Green (RoHS & no Sb/Br): TI defines "Green" to mean Pb-Free (RoHS compatible), and free of Bromine (Br) and Antimony (Sb) based flame retardants (Br or Sb do not exceed 0.1% by weight in homogeneous material)

⁽³⁾ MSL, Peak Temp. -- The Moisture Sensitivity Level rating according to the JEDEC industry standard classifications, and peak solder temperature.

Important Information and Disclaimer: The information provided on this page represents TI's knowledge and belief as of the date that it is provided. TI bases its knowledge and belief on information provided by third parties, and makes no representation or warranty as to the accuracy of such information. Efforts are underway to better integrate information from third parties. TI has taken and continues to take reasonable steps to provide representative and accurate information but may not have conducted destructive testing or chemical analysis on incoming materials and chemicals. TI and TI suppliers consider certain information to be proprietary, and thus CAS numbers and other limited information may not be available for release.

In no event shall TI's liability arising out of such information exceed the total purchase price of the TI part(s) at issue in this document sold by TI to Customer on an annual basis.

TAPE AND REEL INFORMATION

REEL DIMENSIONS

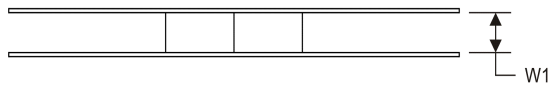
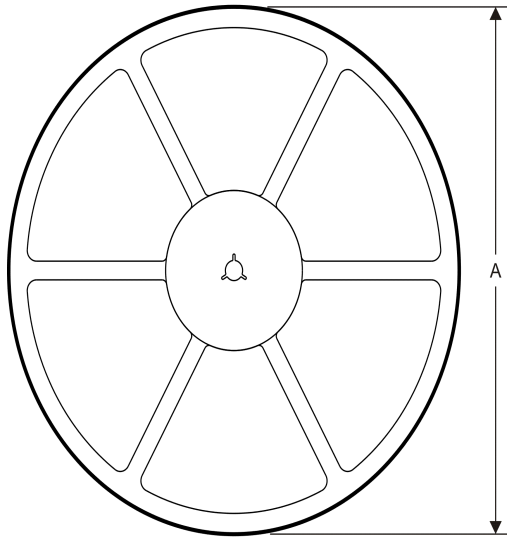

TAPE DIMENSIONS

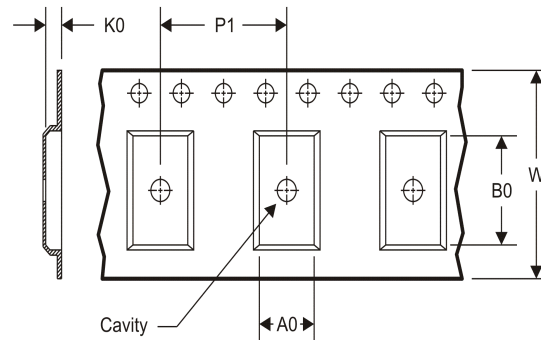

A0	Dimension designed to accommodate the component width
B0	Dimension designed to accommodate the component length
K0	Dimension designed to accommodate the component thickness
W	Overall width of the carrier tape
P1	Pitch between successive cavity centers

TAPE AND REEL INFORMATION

*All dimensions are nominal

Device	Package Type	Package Drawing	Pins	SPQ	Reel Diameter (mm)	Reel Width W1 (mm)	A0 (mm)	B0 (mm)	K0 (mm)	P1 (mm)	W (mm)	Pin1 Quadrant
BQ29400PWR	TSSOP	PW	8	2000	330.0	12.4	7.0	3.6	1.6	8.0	12.0	Q1

TAPE AND REEL BOX DIMENSIONS



*All dimensions are nominal

Device	Package Type	Package Drawing	Pins	SPQ	Length (mm)	Width (mm)	Height (mm)
BQ29400PWR	TSSOP	PW	8	2000	367.0	367.0	35.0

DCT (R-PDSO-G8)

PLASTIC SMALL OUTLINE

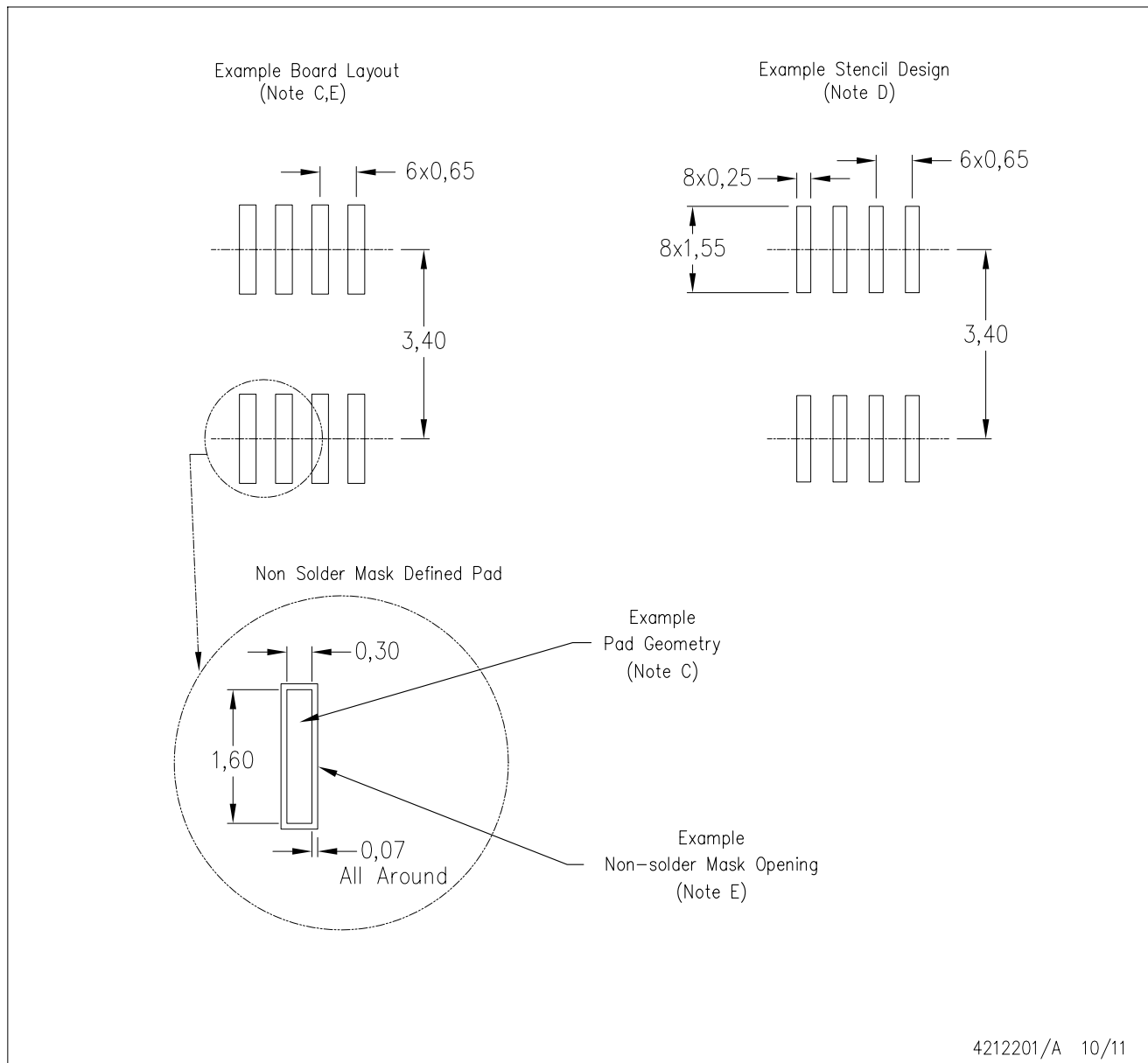

- NOTES:
- A. All linear dimensions are in millimeters.
 - B. This drawing is subject to change without notice.
 - C. Publication IPC-7351 is recommended for alternate designs.
 - D. Laser cutting apertures with trapezoidal walls and also rounding corners will offer better paste release. Customers should contact their board assembly site for stencil design recommendations. Refer to IPC-7525.
 - E. Customers should contact their board fabrication site for solder mask tolerances between and around signal pads.

PW (R-PDSO-G8)

PLASTIC SMALL OUTLINE

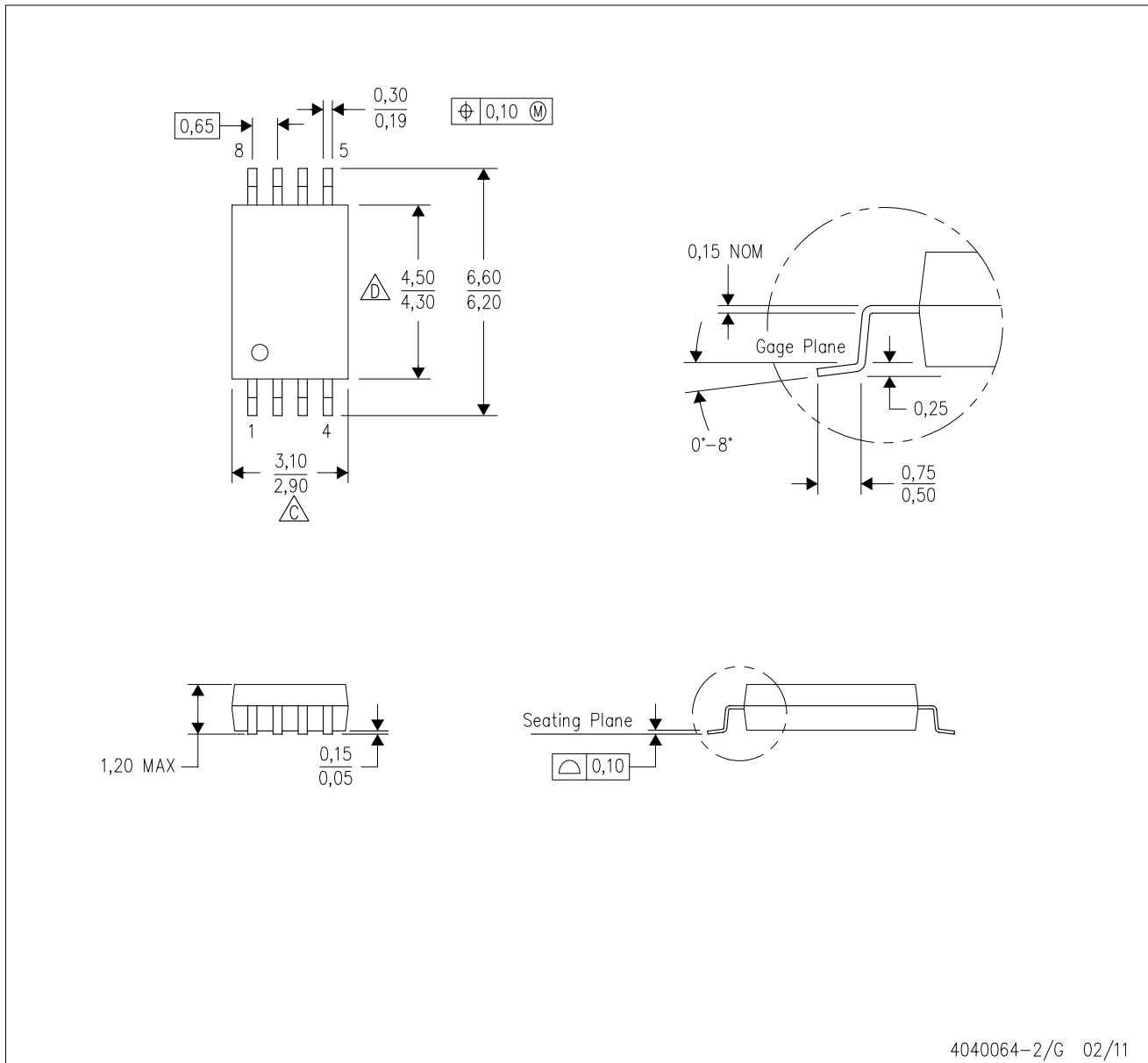

- NOTES:
- A. All linear dimensions are in millimeters. Dimensioning and tolerancing per ASME Y14.5M-1994.
 - B. This drawing is subject to change without notice.
 - C. Body length does not include mold flash, protrusions, or gate burrs. Mold flash, protrusions, or gate burrs shall not exceed 0,15 each side.
 - D. Body width does not include interlead flash. Interlead flash shall not exceed 0,25 each side.
 - E. Falls within JEDEC MO-153

IMPORTANT NOTICE

Texas Instruments Incorporated and its subsidiaries (TI) reserve the right to make corrections, enhancements, improvements and other changes to its semiconductor products and services per JESD46, latest issue, and to discontinue any product or service per JESD48, latest issue. Buyers should obtain the latest relevant information before placing orders and should verify that such information is current and complete. All semiconductor products (also referred to herein as "components") are sold subject to TI's terms and conditions of sale supplied at the time of order acknowledgment.

TI warrants performance of its components to the specifications applicable at the time of sale, in accordance with the warranty in TI's terms and conditions of sale of semiconductor products. Testing and other quality control techniques are used to the extent TI deems necessary to support this warranty. Except where mandated by applicable law, testing of all parameters of each component is not necessarily performed.

TI assumes no liability for applications assistance or the design of Buyers' products. Buyers are responsible for their products and applications using TI components. To minimize the risks associated with Buyers' products and applications, Buyers should provide adequate design and operating safeguards.

TI does not warrant or represent that any license, either express or implied, is granted under any patent right, copyright, mask work right, or other intellectual property right relating to any combination, machine, or process in which TI components or services are used. Information published by TI regarding third-party products or services does not constitute a license to use such products or services or a warranty or endorsement thereof. Use of such information may require a license from a third party under the patents or other intellectual property of the third party, or a license from TI under the patents or other intellectual property of TI.

Reproduction of significant portions of TI information in TI data books or data sheets is permissible only if reproduction is without alteration and is accompanied by all associated warranties, conditions, limitations, and notices. TI is not responsible or liable for such altered documentation. Information of third parties may be subject to additional restrictions.

Resale of TI components or services with statements different from or beyond the parameters stated by TI for that component or service voids all express and any implied warranties for the associated TI component or service and is an unfair and deceptive business practice. TI is not responsible or liable for any such statements.

Buyer acknowledges and agrees that it is solely responsible for compliance with all legal, regulatory and safety-related requirements concerning its products, and any use of TI components in its applications, notwithstanding any applications-related information or support that may be provided by TI. Buyer represents and agrees that it has all the necessary expertise to create and implement safeguards which anticipate dangerous consequences of failures, monitor failures and their consequences, lessen the likelihood of failures that might cause harm and take appropriate remedial actions. Buyer will fully indemnify TI and its representatives against any damages arising out of the use of any TI components in safety-critical applications.

In some cases, TI components may be promoted specifically to facilitate safety-related applications. With such components, TI's goal is to help enable customers to design and create their own end-product solutions that meet applicable functional safety standards and requirements. Nonetheless, such components are subject to these terms.

No TI components are authorized for use in FDA Class III (or similar life-critical medical equipment) unless authorized officers of the parties have executed a special agreement specifically governing such use.

Only those TI components which TI has specifically designated as military grade or "enhanced plastic" are designed and intended for use in military/aerospace applications or environments. Buyer acknowledges and agrees that any military or aerospace use of TI components which have **not** been so designated is solely at the Buyer's risk, and that Buyer is solely responsible for compliance with all legal and regulatory requirements in connection with such use.

TI has specifically designated certain components which meet ISO/TS16949 requirements, mainly for automotive use. Components which have not been so designated are neither designed nor intended for automotive use; and TI will not be responsible for any failure of such components to meet such requirements.

Products

Audio	www.ti.com/audio
Amplifiers	amplifier.ti.com
Data Converters	dataconverter.ti.com
DLP® Products	www.dlp.com
DSP	dsp.ti.com
Clocks and Timers	www.ti.com/clocks
Interface	interface.ti.com
Logic	logic.ti.com
Power Mgmt	power.ti.com
Microcontrollers	microcontroller.ti.com
RFID	www.ti-rfid.com
OMAP Applications Processors	www.ti.com/omap
Wireless Connectivity	www.ti.com/wirelessconnectivity

Applications

Automotive and Transportation	www.ti.com/automotive
Communications and Telecom	www.ti.com/communications
Computers and Peripherals	www.ti.com/computers
Consumer Electronics	www.ti.com/consumer-apps
Energy and Lighting	www.ti.com/energy
Industrial	www.ti.com/industrial
Medical	www.ti.com/medical
Security	www.ti.com/security
Space, Avionics and Defense	www.ti.com/space-avionics-defense
Video and Imaging	www.ti.com/video

TI E2E Community

e2e.ti.com

Mailing Address: Texas Instruments, Post Office Box 655303, Dallas, Texas 75265
Copyright © 2012, Texas Instruments Incorporated