

# AMC80EVM

This user's guide describes the characteristics, operation, and use of the AMC80EVM evaluation board (EVM). It provides a detailed description of the hardware design. It discusses how to set up and configure the software, reviews the hardware, and reviews various aspects of the software operation. Throughout this document, the terms *evaluation board*, *evaluation module*, *test board*, and *EVM* are synonymous with the AMC80EVM. This user's guide also includes information regarding operating procedures and input/output connections, an electrical schematic, printed circuit board (PCB) layout drawings, and a parts list for the AMC80EVM.

## Contents

1	Overview .....	3
2	AMC80EVM Hardware Setup .....	4
3	AMC80EVM Hardware Overview .....	6
4	AMC80EVM Software Setup .....	9
5	AMC80EVM Software Overview .....	11
6	AMC80EVM Documentation .....	19
7	Bill of Materials .....	23

## List of Figures

1	Typical Hardware Included with the AMC80EVM Kit.....	3
2	AMC80EVM Hardware Setup .....	4
3	AMC80 Test Board Block Diagram .....	5
4	SM-USB-DIG Platform Block Diagram .....	6
5	Connecting the SM-USB-DIG Platform to the AMC80 Test Board .....	7
6	USB DIG Platform Driver Installation Confirmation.....	7
7	Unpopulated Pull-Up and Pull-Down Resistors .....	8
8	AMC80EVM Software Install Window .....	9
9	AMC80EVM License Agreements.....	10
10	AMC80EVM Software Interface .....	11
11	Communication Error with USB DIG Platform .....	11
12	AMC80 Preparing to Read from Registers.....	12
13	AMC80 Reading from Registers.....	12
14	AMC80 Writing to Registers .....	13
15	AMC80 Analog Inputs.....	13
16	Max Temp Flag Trigger.....	14
17	Interrupt Inputs.....	14
18	Fan Input Indicators and Divisor Controls.....	15
19	Power-Supply Control.....	15
20	Configuration Register Controls .....	15
21	Manufacturer ID and Stepping/Die Revision ID Controls .....	16

Microsoft, Windows are registered trademarks of Microsoft Corporation.  
 SPI is a trademark of Motorola, Inc.  
 I<sup>2</sup>C is a trademark of NXP Semiconductors.  
 WinZIP is a registered trademark of WinZip International LLC.  
 All other trademarks are the property of their respective owners.

---

22	Registers Tab .....	16
23	Analog Voltages Graphs Tab .....	17
24	Temperature Graph Tab.....	18
25	The FAN Inputs Graph Tab .....	19
26	AMC80EVM Schematic.....	20
27	AMC80EVM PCB: Top Component Layout.....	21
28	AMC80EVM PCB: Bottom Component Layout .....	22

**List of Tables**

1	Contents of AMC80EVM Kit .....	4
2	Related Documentation .....	4
3	AMC80EVM Pin Connectors .....	5
4	AMC80EVM Bill of Materials .....	23

## 1 Overview

The AMC80 is a hardware monitor that communicates over an I<sup>2</sup>C™ interface. The three I<sup>2</sup>C address pins allow up to eight devices on a single bus.

The AMC80 has seven analog inputs that read positive voltages with 10-bit precision together with two fan tachometer inputs, each with internal programmable divisors. The AMC80 performs sequenced comparisons of the analog inputs with internal, programmable limits. When any value exceeds the programmed limit, the interrupt outputs become active. The AMC80 can accept a 3.0V to 5.5V power supply, and is available in a 24-pin TSSOP package.

### 1.1 AMC80EVM Kit Contents

Figure 1 shows all of the hardware included with the AMC80EVM kit. Contact the Texas Instruments Product Information Center nearest you if any component is missing. It is highly recommended that you also check the TI website at <http://www.ti.com> to verify that you have the latest versions of the related software.



**Figure 1. Typical Hardware Included with the AMC80EVM Kit**

Table 1 details the contents of the AMC80EVM kit.

**Table 1. Contents of AMC80EVM Kit**

Item	Quantity
AMC80 PCB Test Board	1
SM-USB-DIG Platform PCB	1
USB Cable Extender	1
User's Guide CD	1
10-Pin Ribbon Cable	1

### 1.2 If You Need Assistance

If you have questions about the AMC80 evaluation module, contact the Linear Amplifiers Applications Team at [precisionamps@list.ti.com](mailto:precisionamps@list.ti.com). Include *AMC80EVM* as the subject heading. Customer support is also available through our user community, which is monitored by TI application engineers, at <http://e2e.ti.com>.

### 1.3 Related Documentation from Texas Instruments

The following documents provide information regarding Texas Instruments' integrated circuits used in the assembly of the AMC80EVM. This user's guide is available from the TI web site under literature number [SBOU101](#). Any letter appended to the literature number corresponds to the document revision that is current at the time of the writing of this document. Newer revisions may be available from the [TI website](#), or call the Texas Instruments' Literature Response Center at (800) 477-8924 or the Product Information Center at (972) 644- 5580. When ordering, identify the document by both title and literature number.

**Table 2. Related Documentation**

Document	Literature Number
<a href="#">AMC80 Product Data Sheet</a>	<a href="#">SBAS500</a>
<a href="#">SM-USB-DIG Platform User's Guide</a>	<a href="#">SBOU098</a>

## 2 AMC80EVM Hardware Setup

The AMC80EVM hardware consists of the SM-USB-DIG Platform and the AMC80 Test Board; these two units are easily connected through a 10-pin, board-to-board connector that should be attached to the SM-USB-DIG Platform and the AMC80EVM. Once these two units are connected, simply plug the USB device from the SM-USB-DIG Platform into the computer, as shown in [Figure 2](#).

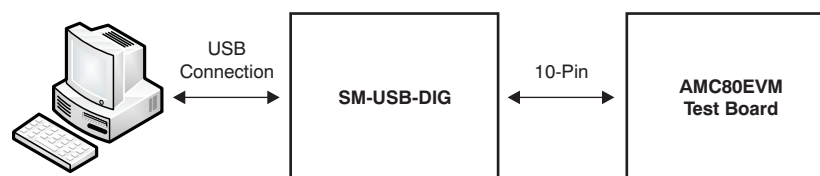

**Figure 2. AMC80EVM Hardware Setup**

## 2.1 Theory of Operation for AMC80EVM

Figure 3 shows the basic architecture of the AMC80 test board. The board requires power and I<sup>2</sup>C communication with the SM-USB-DIG Platform. This configuration allows the AMC80EVM software to communicate with the IC, as well as to simulate and monitor hardware driven interrupts via digital I/O controllers. In addition, headers allow for application specific connections to be used on the AMC80EVM.

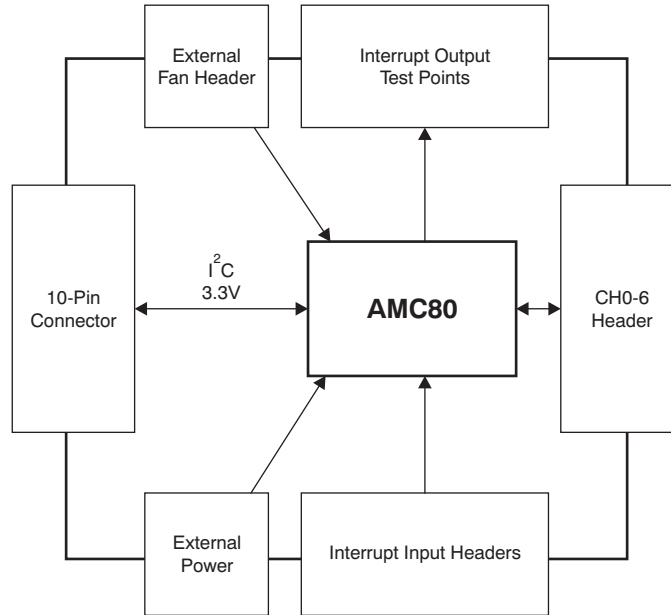

Figure 3. AMC80 Test Board Block Diagram

## 2.2 Signal Definitions of H1 (10-Pin Male Connector Socket)

Table 3 shows the pinout for the 10-pin connector socket used to communicate between the AMC80EVM and the SM-USB-DIG Platform. It should be noted that the AMC80 test board only uses the necessary I<sup>2</sup>C communication lines (pins 1 and 3) and the V<sub>DUT</sub> and GND (pins 6 and 8) pins to issue commands to the AMC80.

Table 3. AMC80EVM Pin Connectors

Pin on U1	Signal	Description
1	I2C_SCL	I <sup>2</sup> C clock signal (SCL)
2	CTRL/MEAS4	GPIO: Control output or measure input
3	I2C_SDA1	I <sup>2</sup> C data signal (SDA)
4	CTRL/MEAS5	GPIO: Control output or measure input
5	SPI_DOUT1	SPI™ data output (MOSI)
6	VDUT	Switchable device under test (DUT) power supply: +3.3V, +5V, Hi-Z (disconnected). <sup>(1)</sup>
7	SPI_CLK	SPI clock signal (SCLK)
8	GND	Power return (GND)
9	SPI_CS1	SPI chip select signal ( $\overline{CS}$ )
10	SPI_DIN1	SPI data input (MISO)

<sup>(1)</sup> When V<sub>DUT</sub> is Hi-Z, all digital I/O are also Hi-Z.

### 2.3 Theory of Operation for SM-USB-DIG Platform

Figure 4 shows the block diagram for the SM-USB-DIG Platform. This platform is a general-purpose data acquisition system that is used on several different Texas Instruments' evaluation modules. The details of its operation are included in [a separate document](#). The block diagram shown in Figure 4 is given as a brief overview of the platform.

The core of the SM-USB-DIG Platform is the [TUSB3210](#), an 8052 microcontroller ( $\mu\text{C}$ ) that has a built-in USB interface. The microcontroller receives information from the host computer that it translates into power, I<sup>2</sup>C, SPI, or other digital I/O patterns. During the digital I/O transaction, the microcontroller reads the response of any device connected to the I/O interface. The response from the device is then sent back to the PC where it is interpreted by the host computer.

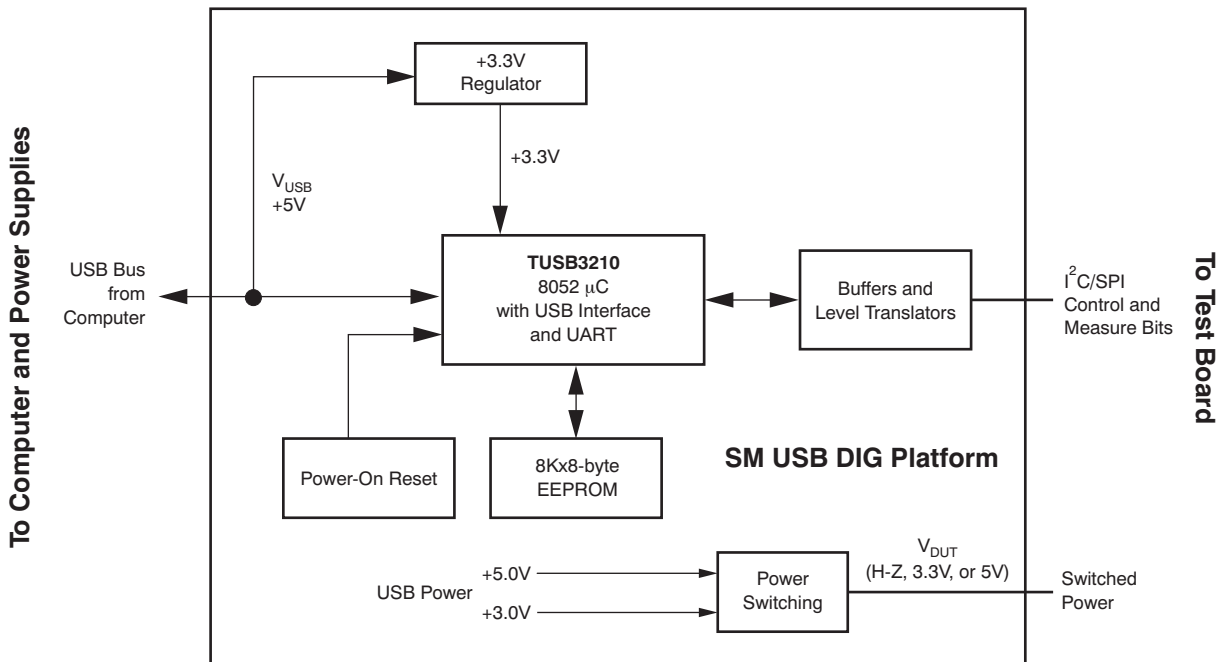

Figure 4. SM-USB-DIG Platform Block Diagram

## 3 AMC80EVM Hardware Overview

### 3.1 Electrostatic Discharge Warning

#### CAUTION

Many of the components on the AMC80EVM are susceptible to damage by electrostatic discharge (ESD). Customers are advised to observe proper ESD handling precautions when unpacking and handling the EVM, including the use of a grounded wrist strap at an approved ESD workstation.

### 3.2 Connecting the Hardware

To connect the AMC80 Test Board and the SM-USB-DIG Platform together, gently slide the male and female ends of the 10-pin connectors together, as illustrated in [Figure 5](#). Make sure that the two connectors are completely pushed together; loose connections may cause intermittent EVM operation.

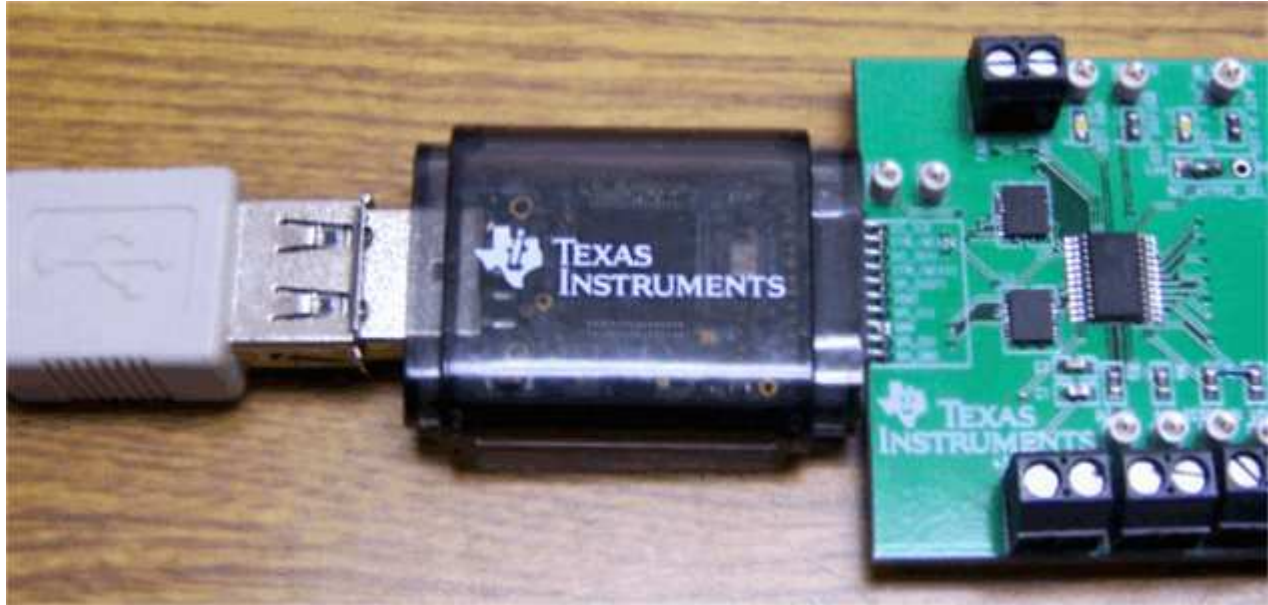

Figure 5. Connecting the SM-USB-DIG Platform to the AMC80 Test Board

### 3.3 Loading the Software

[Figure 6](#) shows the typical response to connecting the SM-USB-DIG Platform board to a PC USB port for the first time. Typically, the computer responds with a *Found New Hardware, USB Device* pop-up dialog. The pop-up window typically changes to *Found New Hardware, USB Human Interface Device*. This pop-up indicates that the device is ready to be used. The SM-USB-DIG Platform uses the human interface device drivers that are part of the Microsoft® Windows® operating system.

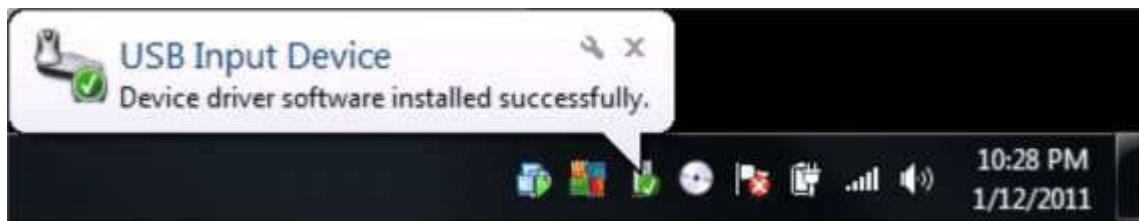

Figure 6. USB DIG Platform Driver Installation Confirmation

### 3.4 AMC80EVM Features

This section describes some of the hardware features present on the AMC80EVM.

#### 3.4.1 External Power and Communication Headers

The AMC80 test board contains headers and test points that allow external power and communication sources to be used on the board. It is recommended that the SM-USB-DIG Platform not be attached when external power and communication are used.

#### 3.4.2 Analog Input Headers

The AMC80EVM features headers that allow connections to be made to the seven analog inputs of the AMC80 device. In addition, the board features unpopulated surface mounts so that pull-up or pull-down resistors may be added if required for a specific application, as shown in [Figure 7](#).

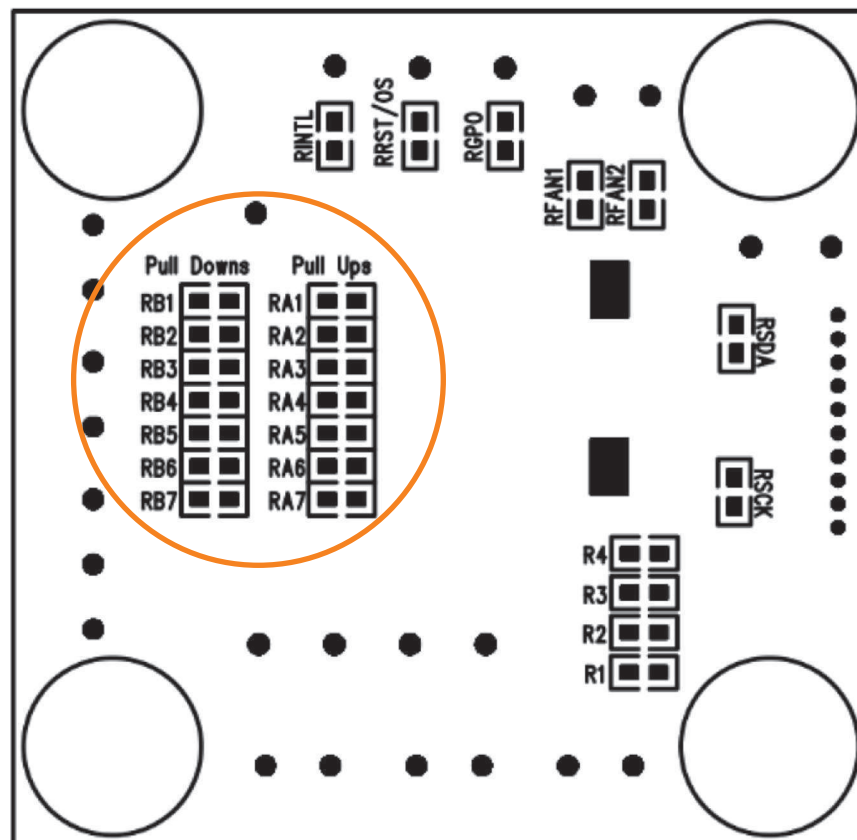

Figure 7. Unpopulated Pull-Up and Pull-Down Resistors

#### 3.4.3 Additional Test Points and Headers

The AMC80 test board features headers and test points connected to the AMC80 interrupts  $\overline{\text{INT\_IN}}$ ,  $\overline{\text{BTI}}$ , GPI, and  $\overline{\text{RESET\_IN}}$ . This configuration allows external hardware triggering of the interrupts. In addition, there are also test points for measuring the interrupt output pins: INT, RST/OS, and GPO. The INT and  $\overline{\text{GPO}}$  interrupt output pins are also connected to LEDs that indicate when the interrupts are active.

The AMC80EVM has a block terminal for easy access to the fan tachometer inputs. These inputs each feature a strong pull-up resistor.

The AMC80EVM PCB also has SDA and SCL test points to monitor the I<sup>2</sup>C bus between the SM-USB-DIG Platform and the AMC80EVM.



## 4 AMC80EVM Software Setup

This section discusses how to install the AMC80EVM software.

### 4.1 Operating Systems for AMC80EVM Software

The AMC80EVM software has been tested on the Microsoft Windows XP operating system (OS) with United States and European regional settings. The software should also function on other Windows operating systems.

### 4.2 AMC80EVM Software Installation

The AMC80EVM software is included on the CD that is shipped with the EVM kit. It is also available through the [AMC80EVM product folder](#) on the TI website. To download the software to your system, insert the disc into an available CD-ROM drive. Navigate to the drive contents and open the AMC80EVM software folder. Locate the compressed file (*AMC80EVM.zip*) and open it. Using WinZIP® or a similar file compression program; extract the AMC80EVM files into a specific AMC80EVM folder (for example, *C:\AMC80\AMC80EVM*) on your hard drive.

Once the files are extracted, navigate to the AMC80EVM folder you created on your hard drive. Locate the *setup.exe* file and execute it to start the installation. The AMC80EVM software installer should begin the installation process as shown in [Figure 8](#).

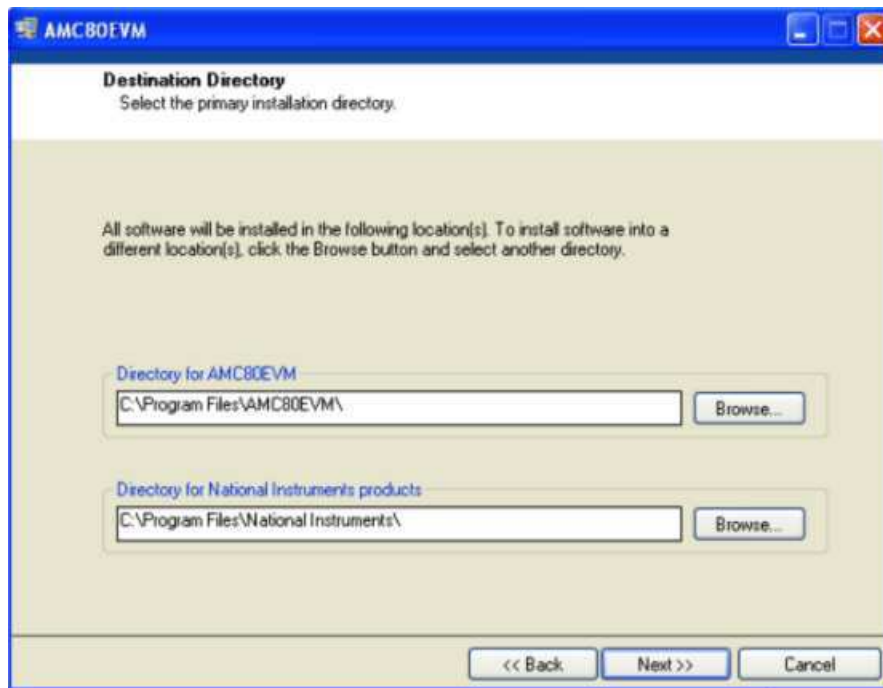

**Figure 8. AMC80EVM Software Install Window**

After the installation process begins, the user must select the directory location where the program will be installed, typically defaulting to *C:\Program Files\AMC80EVM* and *C:\Program Files\National Instruments*.

Following this option, two license agreements are presented that must be accepted as shown in [Figure 9](#). After accepting the Texas Instruments and National Instruments license agreements, the progress bar opens and shows the installation of the software. Once the installation process is completed, click **Finish**.

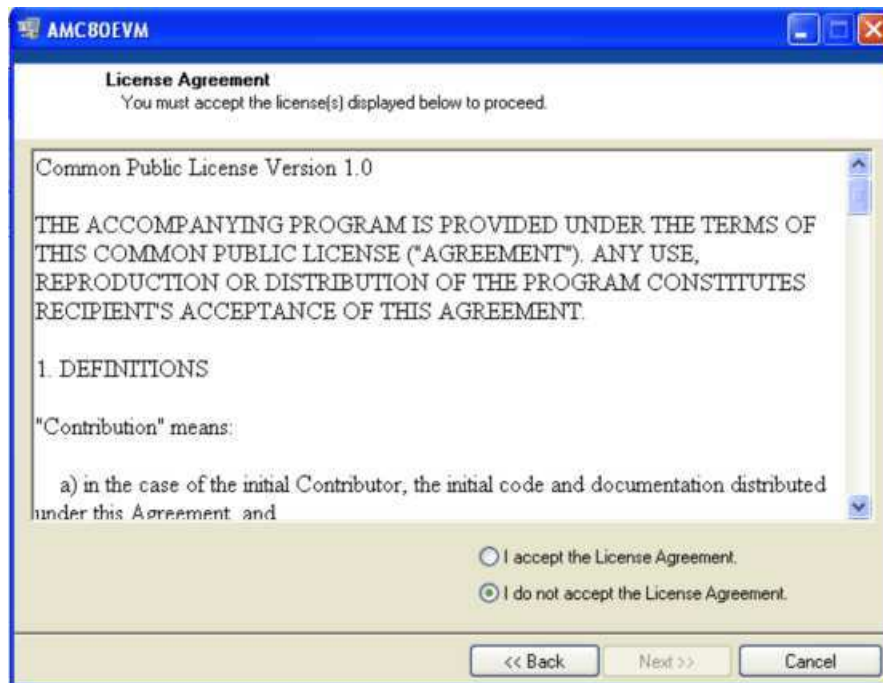

**Figure 9. AMC80EVM License Agreements**

## 5 AMC80EVM Software Overview

This section discusses how to use the AMC80EVM software.

### 5.1 Starting the AMC80EVM Software

The AMC80EVM software can be operated through the *Start* menu in Windows. From the *Start* menu, select *All Programs*; highlight the AMC80 folder, and then select the AMC80EVM program. Figure 10 illustrates how the software should appear when launched.

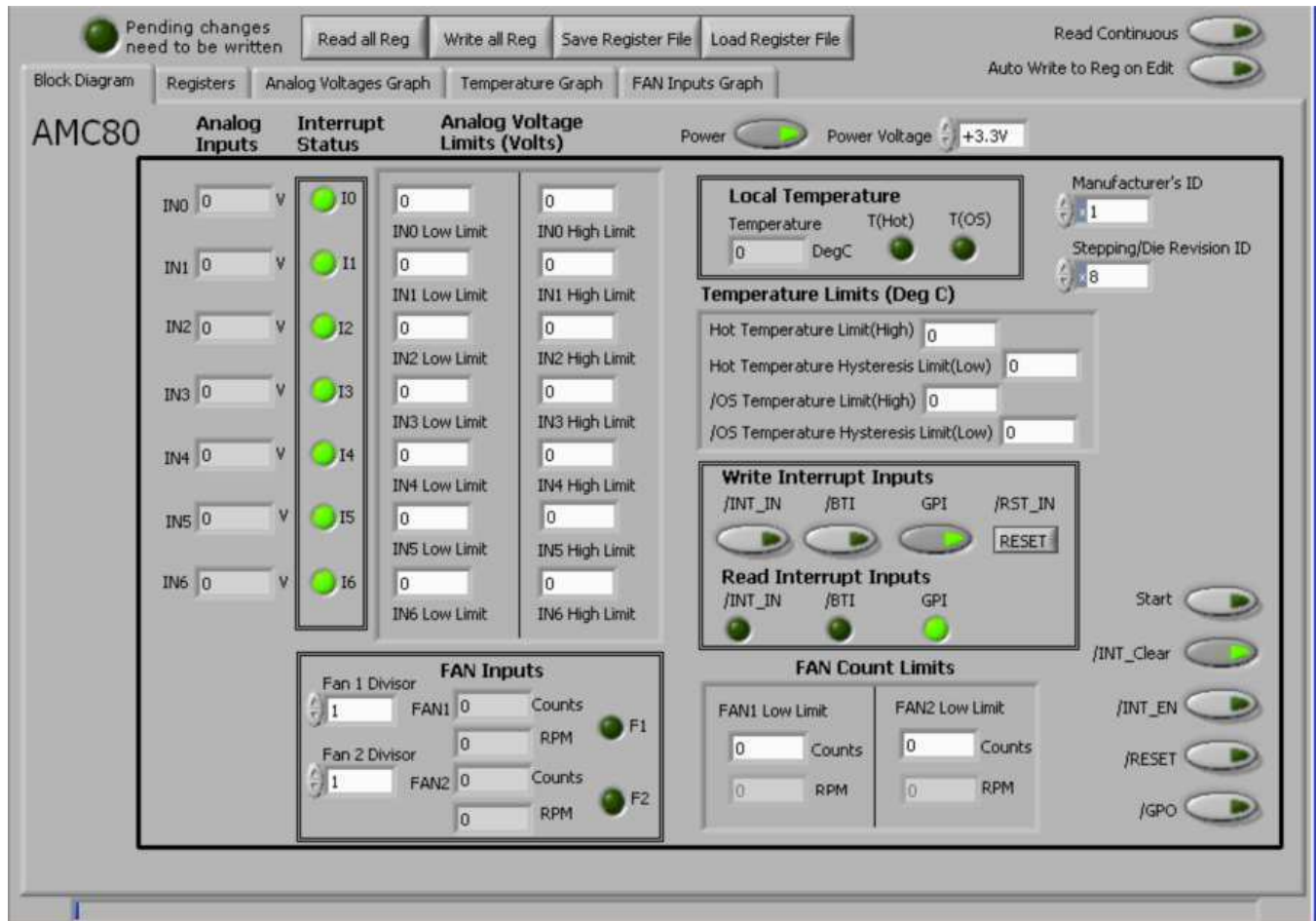

Figure 10. AMC80EVM Software Interface

Figure 11 shows an error that pops up if the computer cannot communicate with the AMC80EVM. If you receive this error, first ensure that the USB cable is properly connected on both ends. Another possible source for this error is a problem with the computer USB Human Interface Device driver. Make sure that when you plug the in the USB cable, the computer recognizes the device. If the sound is on, you will hear the distinctive sound that you expect when a USB device is properly connected to the PC.



Figure 11. Communication Error with USB DIG Platform

## 5.2 Using the AMC80EVM Software

### 5.2.1 Reading from Registers

When first starting the AMC80EVM software, it is advised that the user confirm connections to the board by pressing the **Power** button to provide power to the AMC80. Then press the **Start** button, toggle the **/INT\_Clear** button off (as shown in Figure 12), and press the **Write all Reg** button. This sequence enables the software to monitor all inputs on the AMC80.

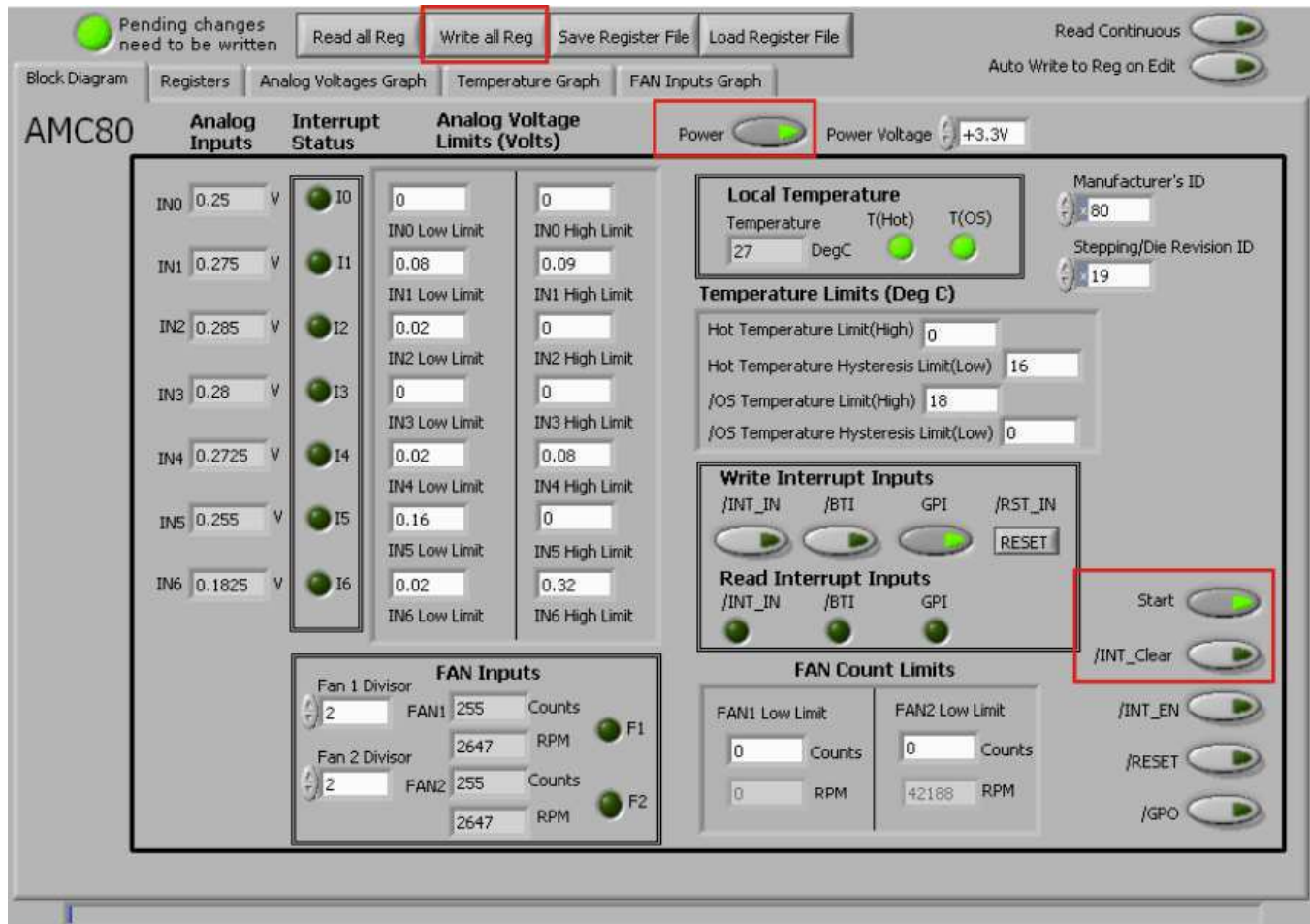

Figure 12. AMC80 Preparing to Read from Registers

To check the status of all device inputs, press the **Read All Reg** button or the **Read Continuous** button, as shown in Figure 13. If the device is functioning correctly, no error messages are displayed.

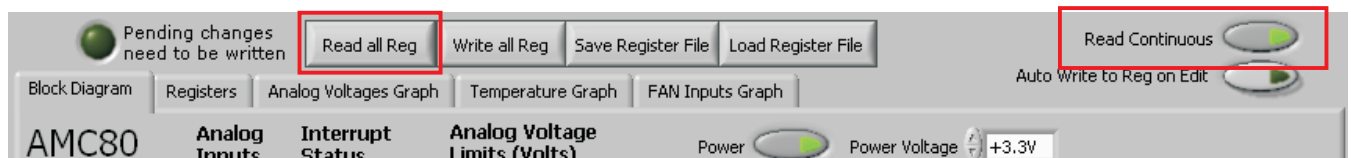

Figure 13. AMC80 Reading from Registers

**NOTE:** The user cannot continuously perform *Read all Register* or *Auto-Write Register* operations by repeatedly pressing the respective button.

### 5.2.2 Writing to Registers

The AMC80EVM software contains two different methods for writing register data: **Write All Reg** and **Auto-Write Reg**. Additionally, register configurations may be saved and recalled using the **Save Register File** and **Load Register File** buttons indicated in [Figure 14](#).

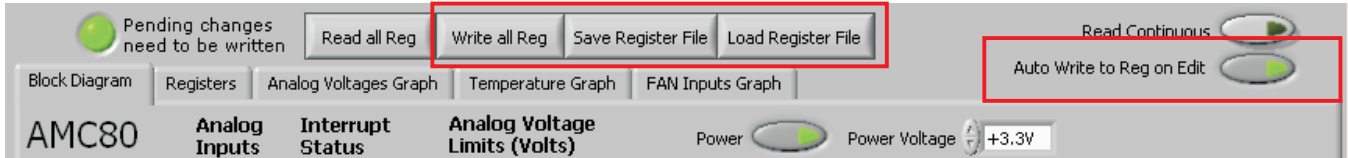

Figure 14. AMC80 Writing to Registers

### 5.2.3 Analog Inputs

[Figure 15](#) shows example data read from an AMC80 device analog inputs. The Interrupt status indicator turns bright green (as shown in [Figure 15](#)) when a high or low limit has been exceeded. The interrupt clears only when the analog voltage is within the limits and the interrupt register has been read at least once. The interrupt indicator then turns dark green.

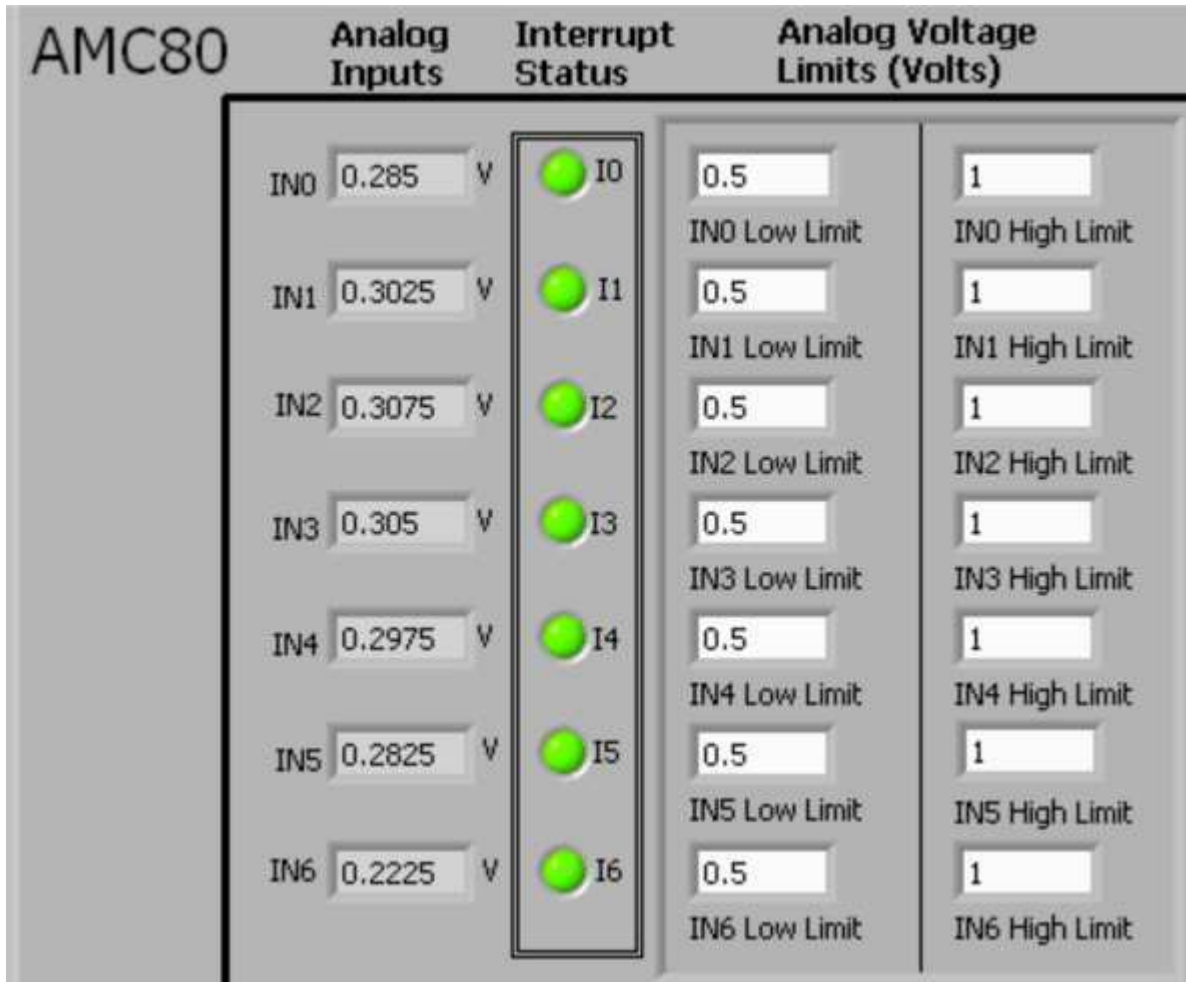

Figure 15. AMC80 Analog Inputs

## 5.2.4 Local Temperature

The AMC80 local temperature sensor data are displayed in degrees Celsius (°C) and has programmable temperature limits, as indicated in Figure 16. The temperature interrupt indicators turn bright green when a limit has been exceeded.

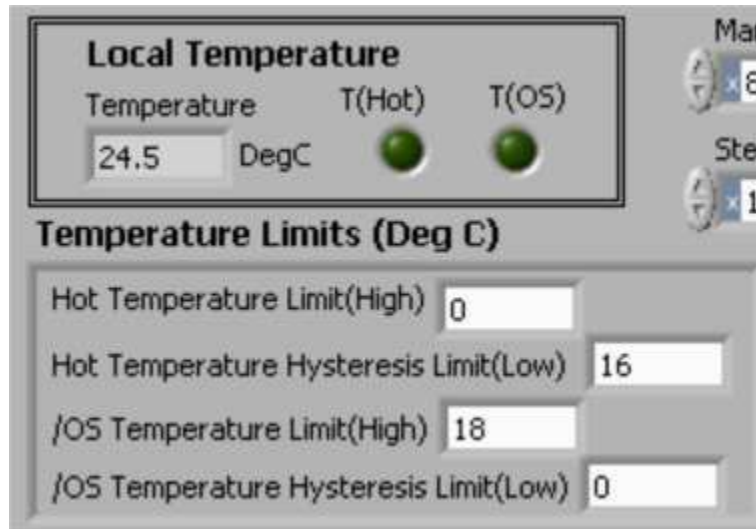

Figure 16. Max Temp Flag Trigger

## 5.2.5 Interrupt Inputs

Toggling the buttons in the Write Interrupt Inputs box shown in Figure 17 and clicking the **Write all Reg** button changes the values of the interrupt inputs to the AMC80. Clicking **Read all Reg** reveals the status of the interrupt registers via the Read Interrupt Inputs indicators. Note that these registers clear only once the input returns to a false value and the register has been read. Clicking the **RESET** button toggles the **RST\_IN** interrupt to the AMC80 low for 50ms.

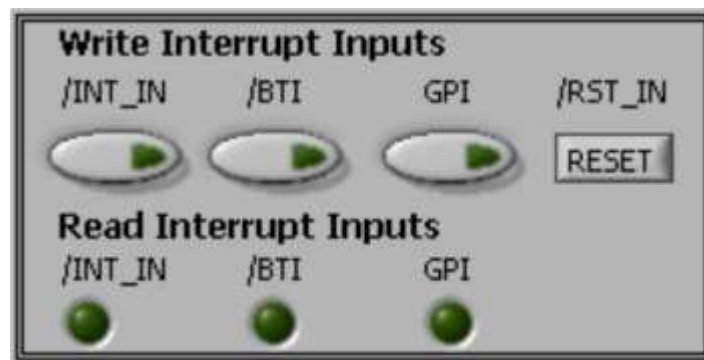

Figure 17. Interrupt Inputs

### 5.2.6 Fan Inputs

As shown in [Figure 18](#), the values read from the AMC80 for FAN1 count and FAN2 count are displayed in the FAN Inputs box in units of counts (see the [AMC80 data sheet](#) for a complete description) and units of RPM. The divisor may also be set by entering a value in the Fan1 Divisor control box or Fan2 Divisor control box, and clicking the **Write all Reg** button.

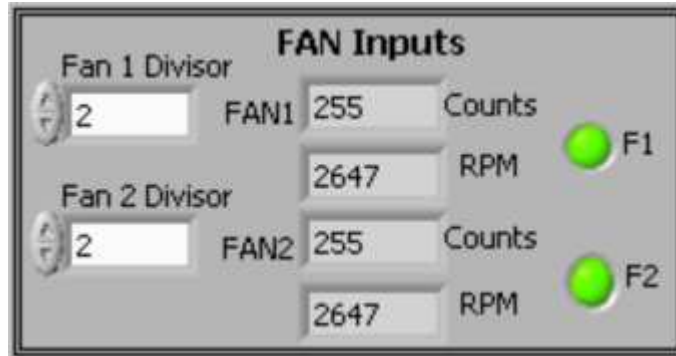

Figure 18. Fan Input Indicators and Divisor Controls

### 5.2.7 Additional Controls

The power supply to the AMC80 may be toggled between +3.3V and +5V by toggling the Power Voltage indicator shown in [Figure 19](#).



Figure 19. Power-Supply Control

Additional control over the Configuration Register is provided on a bit level basis by the controls shown in [Figure 20](#). A bright green indicator represents an active bit, and a dark green indicator represents an inactive bit. After toggling to the desired level, press the **Write all Reg** button to change the Configuration Register.

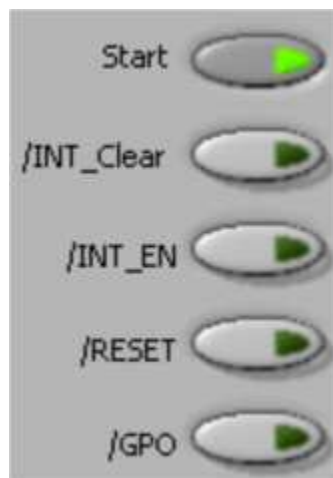
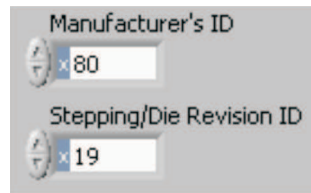

Figure 20. Configuration Register Controls

The Manufacturer ID and Stepping/Die Revision ID registers can be updated by entering a value into the respective control (as shown in Figure 21) and pressing the **Write all Reg** button.



**Figure 21. Manufacturer ID and Stepping/Die Revision ID Controls**

### 5.2.8 Registers Tab

The Registers tab displays the individual register setting for the AMC80 sensors. For more information on the individual registers and the bit meanings, simply highlight the desired register and hit the **Help with Reg** button shown in Figure 22.

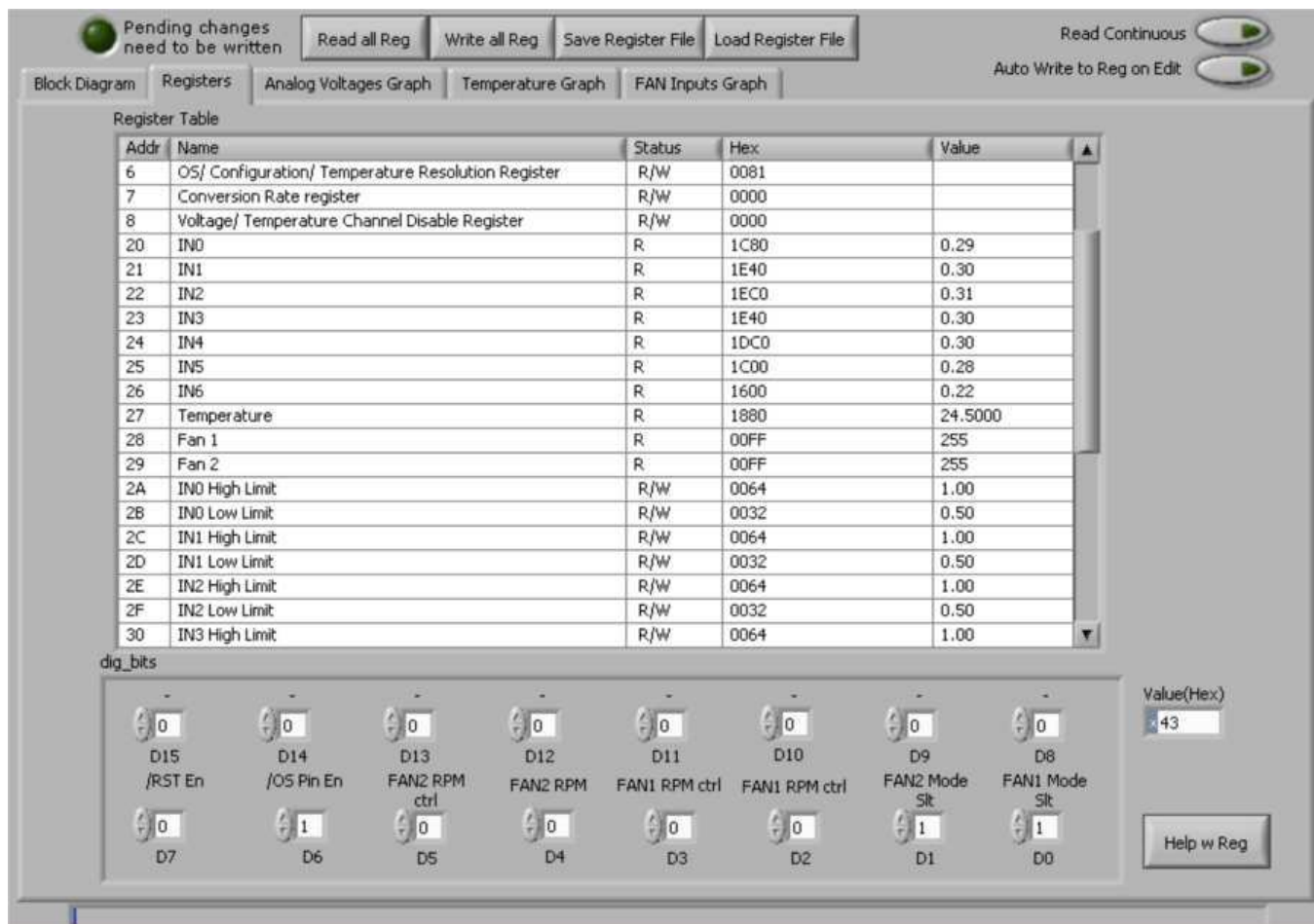

**Figure 22. Registers Tab**

The Registers tab also includes two dig\_bits tables. The dig\_bits tables allow the user to monitor and change individual bits by highlighting the desired register and toggling the bit controls beneath it.

**NOTE:** Only writable register bits can be toggled.



### 5.2.9 Analog Voltages Graph Tab

In Read Continuous mode, the values for each of the seven analog input channels are graphed. The most recent value is also displayed, as Figure 23 illustrates.

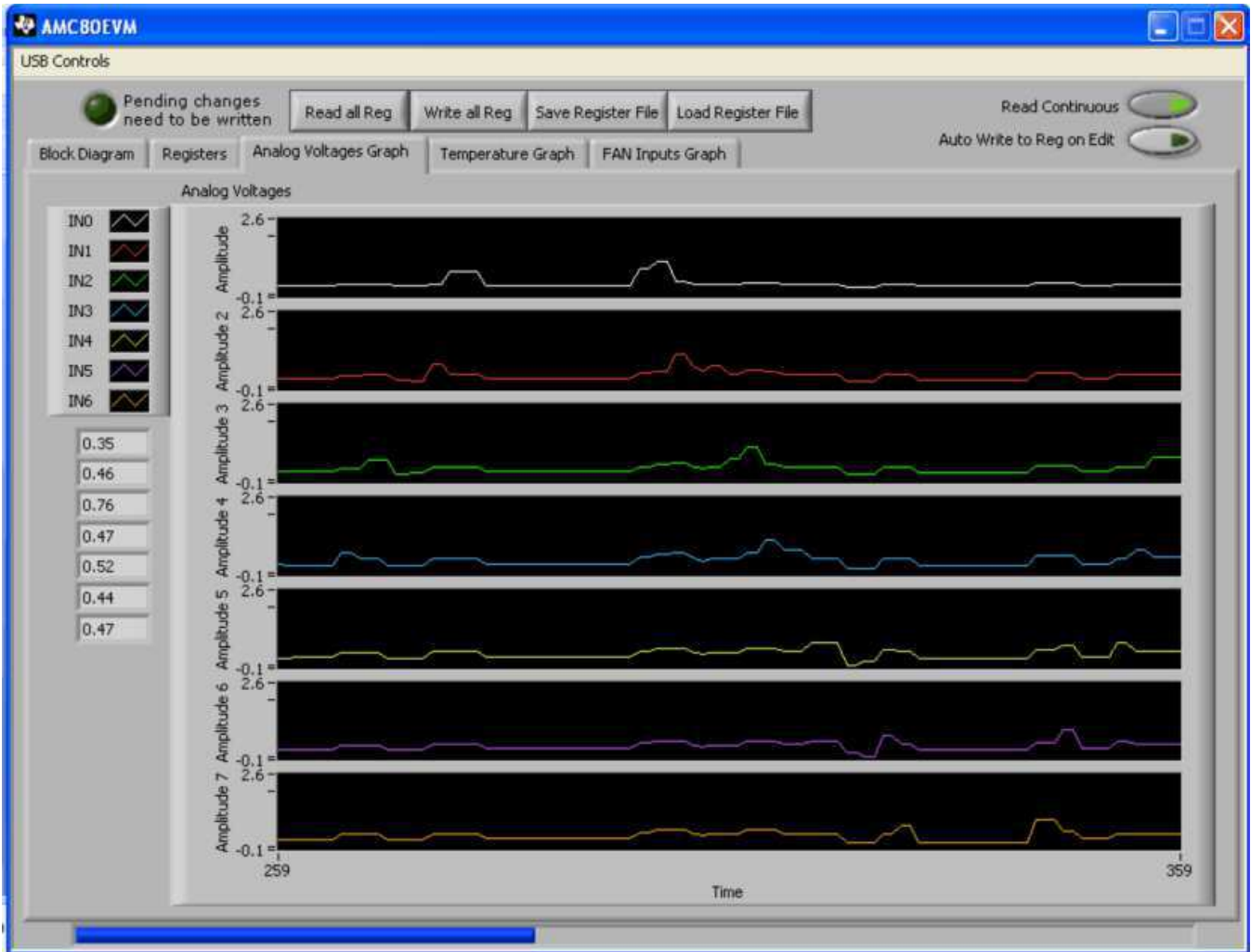

Figure 23. Analog Voltages Graphs Tab

### 5.2.10 Temperature Graph Tab

In Read Continuous mode, the value for each of the local temperature sensor on the AMC80 is plotted in degrees Celsius. The most recent value is also displayed. Figure 24 shows the Temperature Graph tab.

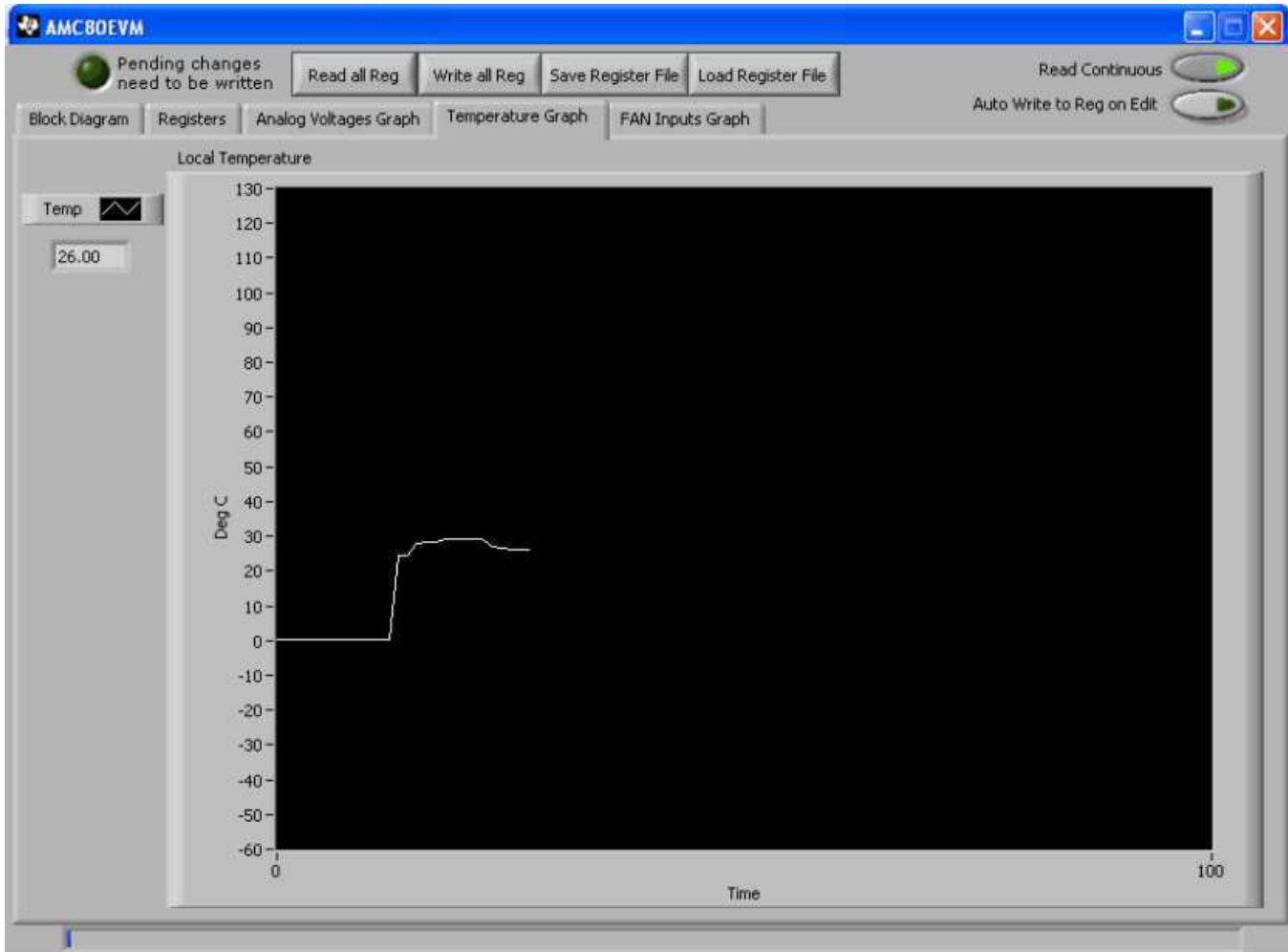

Figure 24. Temperature Graph Tab

### 5.2.11 FAN Inputs Graph Tab

When the Read Continuous button is enabled, the values from the FAN Input registers in the AMC80 are read and displayed in the graphs on this tab. The graphs, as shown in Figure 25, are auto-scaled; the data may be converted to RPMs according to the equations given in the [AMC80 data sheet](#).

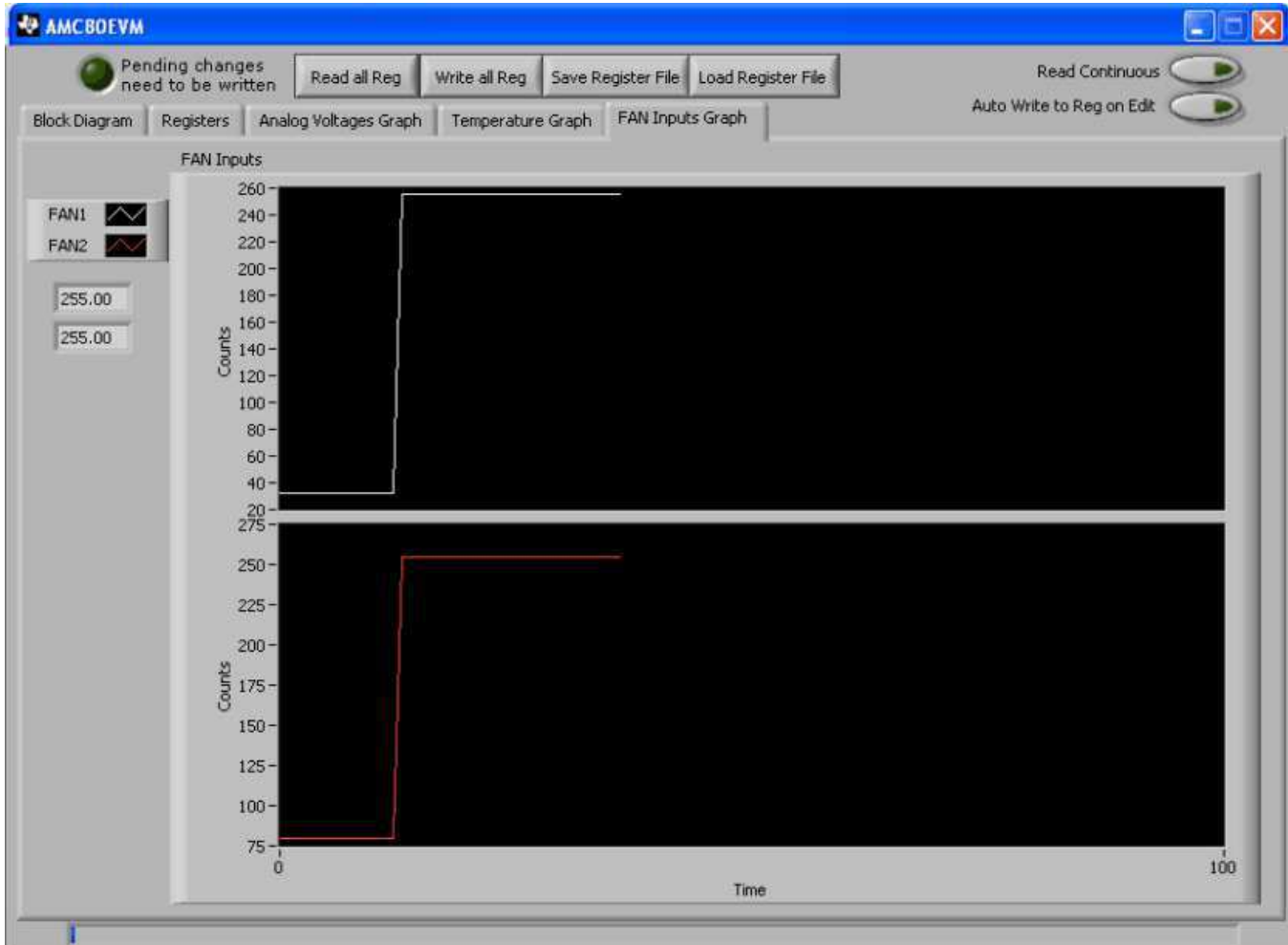

Figure 25. The FAN Inputs Graph Tab

## 6 AMC80EVM Documentation

This section contains the complete bill of materials and schematic diagram for the AMC80EVM. Documentation information for the SM-USB-DIG Platform can be found in the SM-USB-DIG Platform User's Guide, [SBOU098](#), available for download from the TI website at <http://www.ti.com>.

### 6.1 AMC80EVM Board Schematic

Figure 26 shows the schematic for the AMC80EVM board.

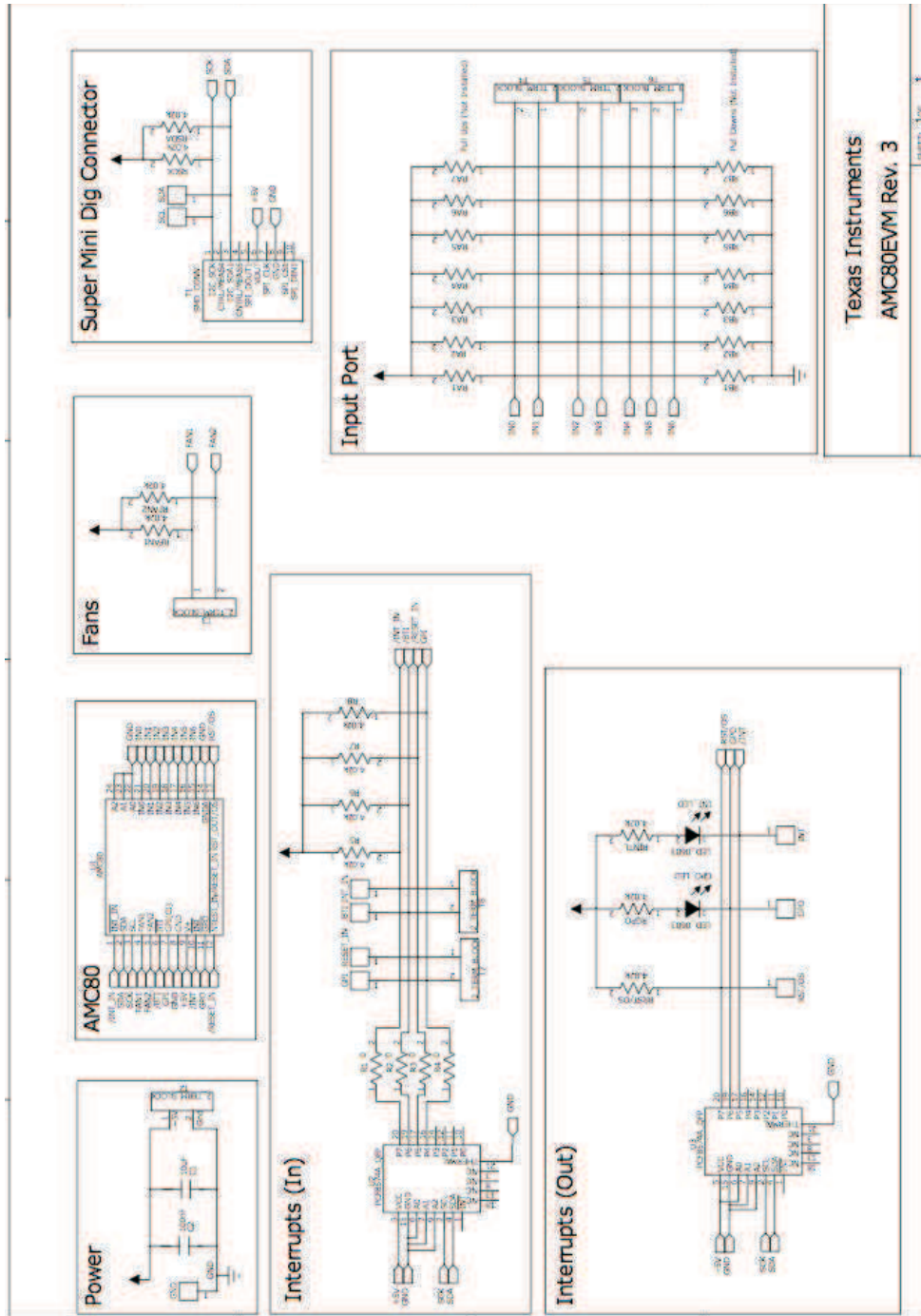

Figure 26. AMC80EVM Schematic

## 6.2 AMC80EVM PCB Component Layout

Figure 27 and Figure 28 show the PCB layout of the components for the AMC80EVM board.

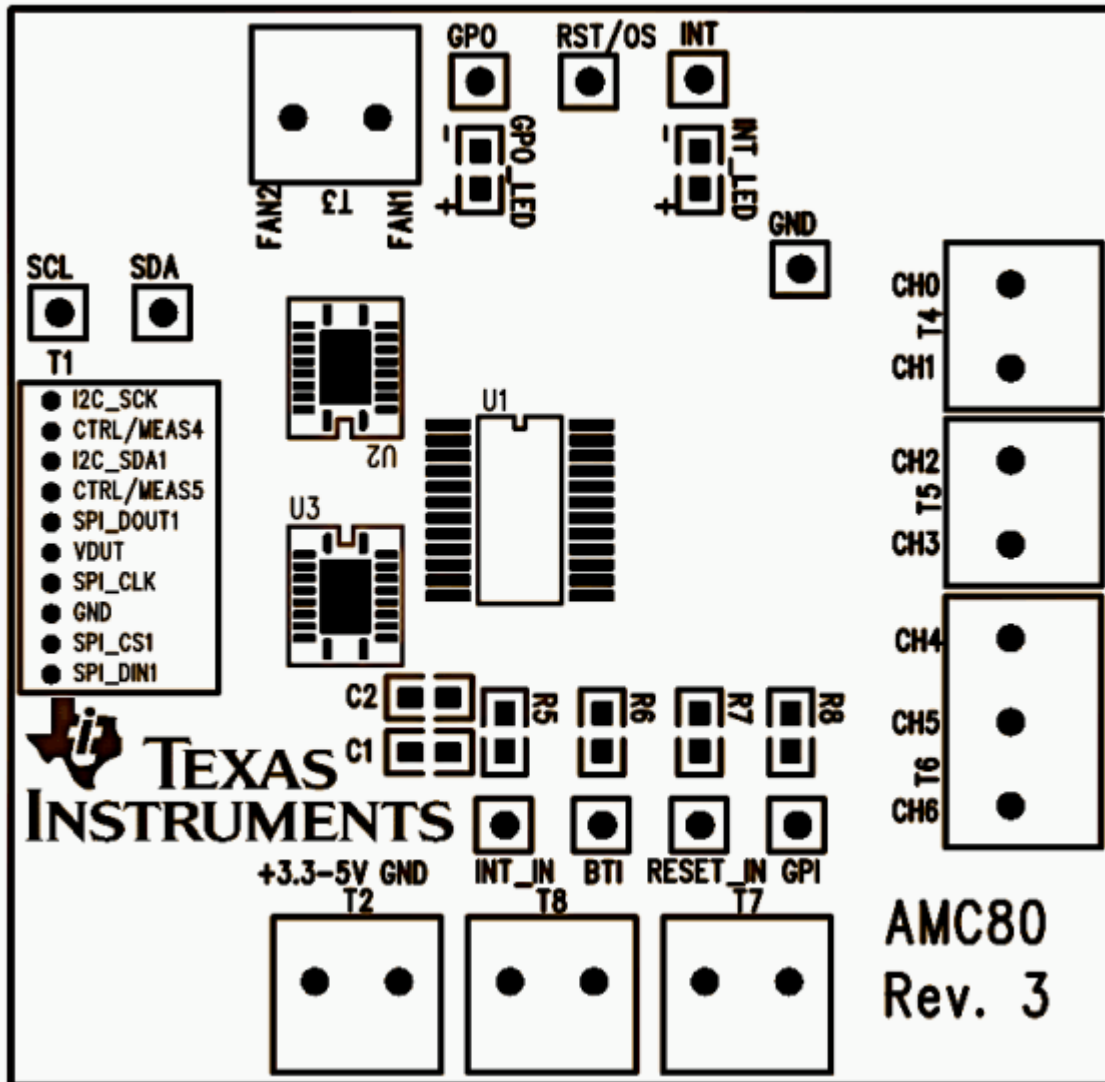

Figure 27. AMC80EVM PCB: Top Component Layout

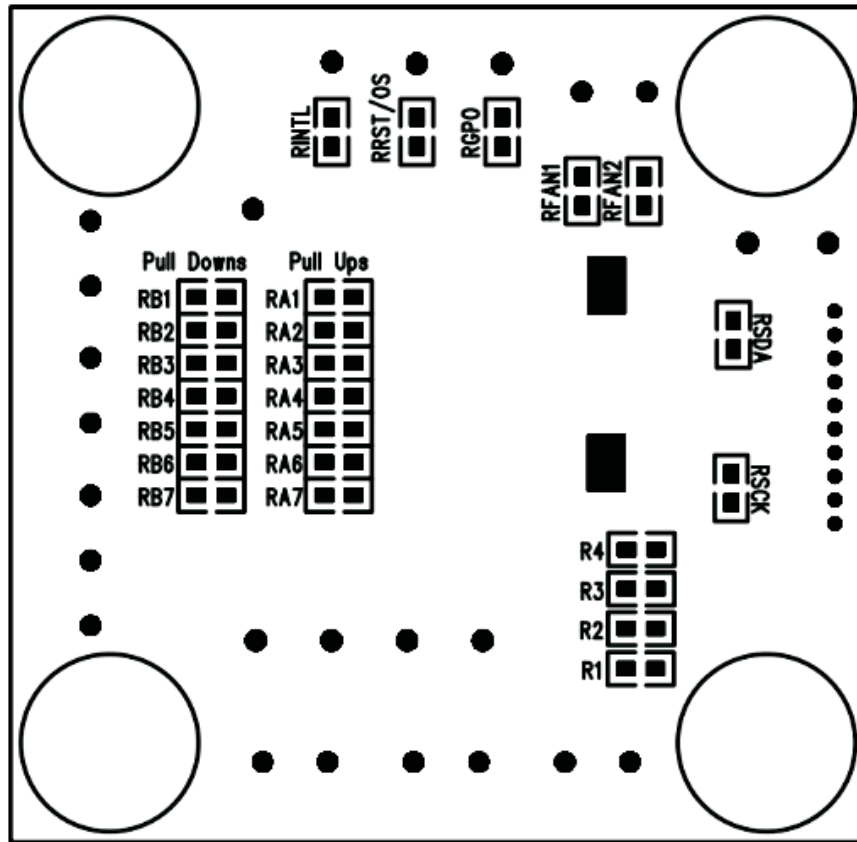

Figure 28. AMC80EVM PCB: Bottom Component Layout

## 7 Bill of Materials

Table 4 shows the parts list for the AMC80EVM.

**Table 4. AMC80EVM Bill of Materials**

Item	Qty	Ref Des	Value	Description	Manufacturer	Part No
1	1	U1	AMC80	AMC80 24-Pin TSSOP	Texas Instruments	AMC80
2	6	T2-T5, T7-T8	Terminal block (2 Position)	2-Block Terminal, 3.5mm	On Shore Technology Inc	ED555/2DS
3	1	T6	Terminal block (3 Position)	3-Block Terminal, 3.5mm	On Shore Technology Inc	ED555/3DS
4	1	C2	100nF	Capacitor, 0.10 $\mu$ F 10V Ceramic X7R 0603	Kemet	C0603C104K8RACTU
5	1	C1	10 $\mu$ F	Capacitor, ceramic 10 $\mu$ F 6.3V X5R 0603	Kemet	C0603C106M9PACTU
6	2	GPO_LED, INT_LED	LED	LED White high bright ESS SMD	Panasonic—SSG	LNJ037X8ARA
7	2	U2-U3	PCF8574a	IC I/O Expander I <sup>2</sup> C 8B 20VQFN	Texas Instruments	PCF8574ARGYR
8	4	R1-R4	0 $\Omega$	Resistor, 0.0 $\Omega$ 1/10W 0603 SMD	Stackpole Electronics Inc	RMCF0603ZT0R00
9	10	R5-R8, RFAN1-RFAN2, RGPO, RINTL, RRST/OS, RSCK, RSDA	4.02k $\Omega$	Resistor, 4.02k $\Omega$ 1/10W 1% 0603 SMD	Stackpole Electronics Inc	RMCF0603FT4K02
10	10	BTI, GND, GPI, GPO, INT INT_IN, RESET_IN, RST/OS, SCL, SDA	Test point	Test Point PC Mini 0.040"D white	Keystone	TP_MINI_THM
11	1	T1	Header (10-position)	Connector, Socket Rt Ang 10-Pos .050	Mill-Max Manufacturing Corp.	851-93-010-20-001000
12	4	NA	Bumpons	Bumpon Cylindrical .375X.135 BLK	3M	SJ61A8

## Evaluation Board/Kit Important Notice

Texas Instruments (TI) provides the enclosed product(s) under the following conditions:

This evaluation board/kit is intended for use for **ENGINEERING DEVELOPMENT, DEMONSTRATION, OR EVALUATION PURPOSES ONLY** and is not considered by TI to be a finished end-product fit for general consumer use. Persons handling the product(s) must have electronics training and observe good engineering practice standards. As such, the goods being provided are not intended to be complete in terms of required design-, marketing-, and/or manufacturing-related protective considerations, including product safety and environmental measures typically found in end products that incorporate such semiconductor components or circuit boards. This evaluation board/kit does not fall within the scope of the European Union directives regarding electromagnetic compatibility, restricted substances (RoHS), recycling (WEEE), FCC, CE or UL, and therefore may not meet the technical requirements of these directives or other related directives.

Should this evaluation board/kit not meet the specifications indicated in the User's Guide, the board/kit may be returned within 30 days from the date of delivery for a full refund. **THE FOREGOING WARRANTY IS THE EXCLUSIVE WARRANTY MADE BY SELLER TO BUYER AND IS IN LIEU OF ALL OTHER WARRANTIES, EXPRESSED, IMPLIED, OR STATUTORY, INCLUDING ANY WARRANTY OF MERCHANTABILITY OR FITNESS FOR ANY PARTICULAR PURPOSE.**

The user assumes all responsibility and liability for proper and safe handling of the goods. Further, the user indemnifies TI from all claims arising from the handling or use of the goods. Due to the open construction of the product, it is the user's responsibility to take any and all appropriate precautions with regard to electrostatic discharge.

**EXCEPT TO THE EXTENT OF THE INDEMNITY SET FORTH ABOVE, NEITHER PARTY SHALL BE LIABLE TO THE OTHER FOR ANY INDIRECT, SPECIAL, INCIDENTAL, OR CONSEQUENTIAL DAMAGES.**

TI currently deals with a variety of customers for products, and therefore our arrangement with the user **is not exclusive.**

TI assumes **no liability for applications assistance, customer product design, software performance, or infringement of patents or services described herein.**

Please read the User's Guide and, specifically, the Warnings and Restrictions notice in the User's Guide prior to handling the product. This notice contains important safety information about temperatures and voltages. For additional information on TI's environmental and/or safety programs, please contact the TI application engineer or visit [www.ti.com/esh](http://www.ti.com/esh).

No license is granted under any patent right or other intellectual property right of TI covering or relating to any machine, process, or combination in which such TI products or services might be or are used.

## FCC Warning

This evaluation board/kit is intended for use for **ENGINEERING DEVELOPMENT, DEMONSTRATION, OR EVALUATION PURPOSES ONLY** and is not considered by TI to be a finished end-product fit for general consumer use. It generates, uses, and can radiate radio frequency energy and has not been tested for compliance with the limits of computing devices pursuant to part 15 of FCC rules, which are designed to provide reasonable protection against radio frequency interference. Operation of this equipment in other environments may cause interference with radio communications, in which case the user at his own expense will be required to take whatever measures may be required to correct this interference.

## EVM Warnings and Restrictions

It is important to operate this EVM within the input voltage range of 0V (min) to 5.5V (max) and the output voltage range of 0V (min) to 5.5V (max).

Exceeding the specified input range may cause unexpected operation and/or irreversible damage to the EVM. If there are questions concerning the input range, please contact a TI field representative prior to connecting the input power.

Applying loads outside of the specified output range may result in unintended operation and/or possible permanent damage to the EVM. Please consult the EVM User's Guide prior to connecting any load to the EVM output. If there is uncertainty as to the load specification, please contact a TI field representative.

During normal operation, some circuit components may have case temperatures greater than +25°C. The EVM is designed to operate properly with certain components above +25°C as long as the input and output ranges are maintained. These components include but are not limited to linear regulators, switching transistors, pass transistors, and current sense resistors. These types of devices can be identified using the EVM schematic located in the EVM User's Guide. When placing measurement probes near these devices during operation, please be aware that these devices may be very warm to the touch.

Mailing Address: Texas Instruments, Post Office Box 655303, Dallas, Texas 75265  
Copyright © 2011, Texas Instruments Incorporated



## IMPORTANT NOTICE

Texas Instruments Incorporated and its subsidiaries (TI) reserve the right to make corrections, modifications, enhancements, improvements, and other changes to its products and services at any time and to discontinue any product or service without notice. Customers should obtain the latest relevant information before placing orders and should verify that such information is current and complete. All products are sold subject to TI's terms and conditions of sale supplied at the time of order acknowledgment.

TI warrants performance of its hardware products to the specifications applicable at the time of sale in accordance with TI's standard warranty. Testing and other quality control techniques are used to the extent TI deems necessary to support this warranty. Except where mandated by government requirements, testing of all parameters of each product is not necessarily performed.

TI assumes no liability for applications assistance or customer product design. Customers are responsible for their products and applications using TI components. To minimize the risks associated with customer products and applications, customers should provide adequate design and operating safeguards.

TI does not warrant or represent that any license, either express or implied, is granted under any TI patent right, copyright, mask work right, or other TI intellectual property right relating to any combination, machine, or process in which TI products or services are used. Information published by TI regarding third-party products or services does not constitute a license from TI to use such products or services or a warranty or endorsement thereof. Use of such information may require a license from a third party under the patents or other intellectual property of the third party, or a license from TI under the patents or other intellectual property of TI.

Reproduction of TI information in TI data books or data sheets is permissible only if reproduction is without alteration and is accompanied by all associated warranties, conditions, limitations, and notices. Reproduction of this information with alteration is an unfair and deceptive business practice. TI is not responsible or liable for such altered documentation. Information of third parties may be subject to additional restrictions.

Resale of TI products or services with statements different from or beyond the parameters stated by TI for that product or service voids all express and any implied warranties for the associated TI product or service and is an unfair and deceptive business practice. TI is not responsible or liable for any such statements.

TI products are not authorized for use in safety-critical applications (such as life support) where a failure of the TI product would reasonably be expected to cause severe personal injury or death, unless officers of the parties have executed an agreement specifically governing such use. Buyers represent that they have all necessary expertise in the safety and regulatory ramifications of their applications, and acknowledge and agree that they are solely responsible for all legal, regulatory and safety-related requirements concerning their products and any use of TI products in such safety-critical applications, notwithstanding any applications-related information or support that may be provided by TI. Further, Buyers must fully indemnify TI and its representatives against any damages arising out of the use of TI products in such safety-critical applications.

TI products are neither designed nor intended for use in military/aerospace applications or environments unless the TI products are specifically designated by TI as military-grade or "enhanced plastic." Only products designated by TI as military-grade meet military specifications. Buyers acknowledge and agree that any such use of TI products which TI has not designated as military-grade is solely at the Buyer's risk, and that they are solely responsible for compliance with all legal and regulatory requirements in connection with such use.

TI products are neither designed nor intended for use in automotive applications or environments unless the specific TI products are designated by TI as compliant with ISO/TS 16949 requirements. Buyers acknowledge and agree that, if they use any non-designated products in automotive applications, TI will not be responsible for any failure to meet such requirements.

Following are URLs where you can obtain information on other Texas Instruments products and application solutions:

### Products

Audio	<a href="http://www.ti.com/audio">www.ti.com/audio</a>
Amplifiers	<a href="http://amplifier.ti.com">amplifier.ti.com</a>
Data Converters	<a href="http://dataconverter.ti.com">dataconverter.ti.com</a>
DLP® Products	<a href="http://www.dlp.com">www.dlp.com</a>
DSP	<a href="http://dsp.ti.com">dsp.ti.com</a>
Clocks and Timers	<a href="http://www.ti.com/clocks">www.ti.com/clocks</a>
Interface	<a href="http://interface.ti.com">interface.ti.com</a>
Logic	<a href="http://logic.ti.com">logic.ti.com</a>
Power Mgmt	<a href="http://power.ti.com">power.ti.com</a>
Microcontrollers	<a href="http://microcontroller.ti.com">microcontroller.ti.com</a>
RFID	<a href="http://www.ti-rfid.com">www.ti-rfid.com</a>
RF/IF and ZigBee® Solutions	<a href="http://www.ti.com/lprf">www.ti.com/lprf</a>

### Applications

Communications and Telecom	<a href="http://www.ti.com/communications">www.ti.com/communications</a>
Computers and Peripherals	<a href="http://www.ti.com/computers">www.ti.com/computers</a>
Consumer Electronics	<a href="http://www.ti.com/consumer-apps">www.ti.com/consumer-apps</a>
Energy and Lighting	<a href="http://www.ti.com/energy">www.ti.com/energy</a>
Industrial	<a href="http://www.ti.com/industrial">www.ti.com/industrial</a>
Medical	<a href="http://www.ti.com/medical">www.ti.com/medical</a>
Security	<a href="http://www.ti.com/security">www.ti.com/security</a>
Space, Avionics and Defense	<a href="http://www.ti.com/space-avionics-defense">www.ti.com/space-avionics-defense</a>
Transportation and Automotive	<a href="http://www.ti.com/automotive">www.ti.com/automotive</a>
Video and Imaging	<a href="http://www.ti.com/video">www.ti.com/video</a>
Wireless	<a href="http://www.ti.com/wireless-apps">www.ti.com/wireless-apps</a>

TI E2E Community Home Page

[e2e.ti.com](http://e2e.ti.com)

Mailing Address: Texas Instruments, Post Office Box 655303, Dallas, Texas 75265  
Copyright © 2011, Texas Instruments Incorporated