

Quasi-Parallel Sound Processor for TV Sets

Technology: Bipolar

Features

- High signal sensitivity
 - Simple filter configuration and few external components
 - Processing of two carrier stereo signals
 - ESD protected
 - Low intercarrier distortions
 - Alignment-free intercarrier mixer
 - Optimum tuning characteristics
 - Improved linearity for NICAM applications
 - AF output level matched to SIMAVELEC condition
- Case:** DIP18

Block Diagram

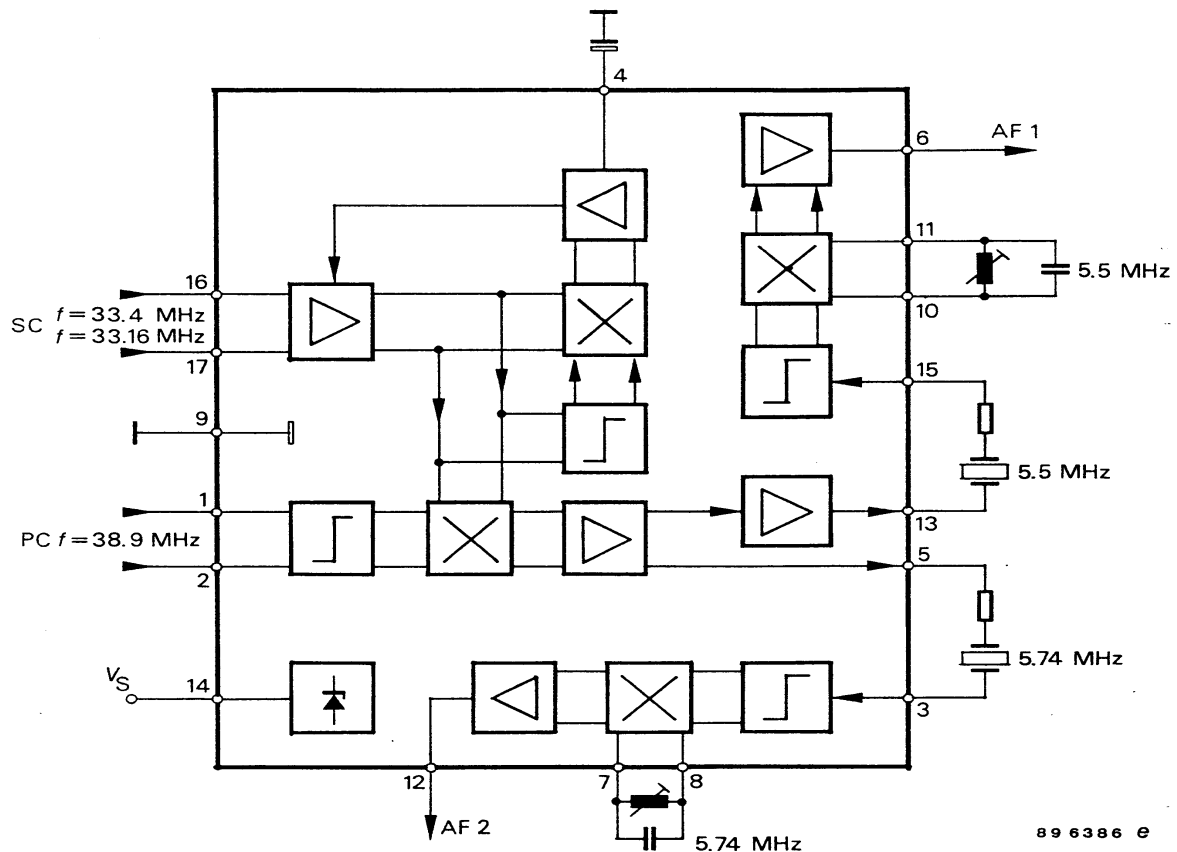

Figure 1.

Pin Configuration

Pin	Function
1–2	Vision-IF-carrier input
3	Inter-carrier input 5.74 MHz
4	AGC storage capacitor
5	Inter-carrier output 5.74 MHz
6	AF output 1
7–8	FM demod circuit 5.74 MHz
9	Ground

Pin	Function
10–11	FM-demode circuit 5.5 MHz
12	AF output 2
13	Inter-carrier output 5.5 MHz
14	Supply voltage
15	Inter-carrier input 5.5 MHz
16–17	Sound-IF-carrier input
18	Not connected

Circuit Description

This circuit configuration permits high-quality processing of audio carriers for FM-sound standards, providing separate inputs for the video and audio carrier. The audio carrier signal is passed to two multiplying mixer arrangements via a 3-stage variable wideband amplifier with led level output signals. One mixer generates the gain-control signal. The second mixer operates as an inter-carrier demodulator and supplies the intermediate AF carrier. The video carrier signal required from the inter-carrier is decoupled in a prelimited and selected form from the demodulator tank of the intermediate video frequency circuit (TDA4453 or

TDA4439) and led to the inter-carrier mixer via a limiting amplifier. Depending on the system, the Nyquist range of the IF input filter in the video channel affects the attainable AF signal-to-noise ratio.

The audio PM IF carrier reaches the quadrature demodulators via an inter-connected IF filter and subsequent limiting amplifier. The resulting AF signals are led via a low-pass amplifier with increased level to the buffered output stages. Switching can take place with TTL-equivalent levels.

Absolute Maximum Ratings

Reference point Pin 9, 18, unless otherwise specified

Parameters	Symbol	Value	Unit
Supply voltage Pin 14	V_S	10 to 13.5	V
Supply current Pin 14	I_S	80	mA
External voltages Pins 1, 2, 3, 4, 5, 7, 8, 10, 11, 12, 13, 15, 16 and 17	V_{ext}	6	V
Power dissipation (in soldered position)	P_{tot}	1	W
Junction temperature	T_j	125	°C
Ambient temperature range	T_{amb}	–25 to +70	°C
Storage temperature range	T_{stg}	–25 to +125	°C

Thermal Resistance

Parameters	Symbol	Maximum	Unit
Junction ambient	R_{thJA}	60	K/W

Electrical Characteristics

$V_S = 12\text{ V}$, $T_{\text{amb}} = 25^\circ\text{C}$, reference point Pin 9, $f_{\text{PC}} = 38.9\text{ MHz}$, $f_{\text{SC1}} = 33.43\text{ MHz}$, $f_{\text{SC2}} = 33.1578\text{ MHz}$, $\text{SC1/SC2} = 7\text{ dB}$, unless otherwise specified

Parameters	Test Conditions / Pin	Symbol	Min	Typ	Max	Unit
Supply voltage range	Pin 14	V_S	10		13.5	V
Supply current	Pin 14	I_S	55	62	80	mA
Output dc voltage	Pin 6, 12	V_0		3.6		V
Picture carrier input voltage	Pin 1-2	v	10	20	30	mV
Min. sound carrier input voltage SC1	(5.5 MHz-output signal -3 dB) Pin 16-17	v		50		μV
AGC range			60	65		dB
Audio output voltage	FM deviation = 27 kHz, Pin 6, 12	v		500		mV
Audio-voltage difference between both outputs	Pin 6, 12	Δv_{AF}			1	dB
Harmonic distortion ¹⁾	$f_{\text{mod}} = 1\text{ kHz}$, FM deviation = 30 kHz Pin 6, 12	THD		0.5		%
Limiting threshold	($V_{\text{AF}} - 3\text{ dB}$)			250		μV
AM rejection	$f_{\text{mod}} = 1\text{ kHz}$, $m = 30\%$ ³⁾ $V_{3(15)} = 10\text{ mV}$, $f = 5.5\text{ (5.74) MHz}$			55		dB
FM amplifier input resistance		$R_{3,15}$		560		Ω
Min. output load	Pin 6,12	R	3			k Ω
Signal-to-noise ratio (standard B/G) according to CCIR 468-2 specifications v_{16-17} : SC1 = 10 mV, SC2 = 4.5 V PC: $v_{1-2} = 20\text{ mV}$, prelimited demodulator picture carrier signal from TDA4453						
Black burst	1. channel/ 2. channel ^{2,3)} Pin 6,12	(S+N)/N		62/60		dB
Grid test signal	1. channel/ 2. channel ^{2,3)} Pin 6,12	(S+N)/N		50/48		dB

- 1) FM tank circuits: operation quality factor = 22
- 2) Standard B/G IF-modulated FBAS signal
- 3) Reference signal: $f_{\text{mod}} = 1\text{ kHz}$, FM deviation = 30 kHz

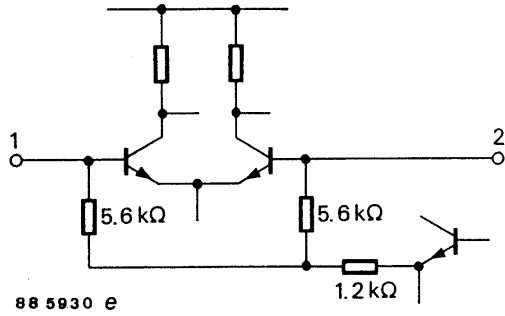

Figure 2. Pin 1, 2: IF input vision carrier

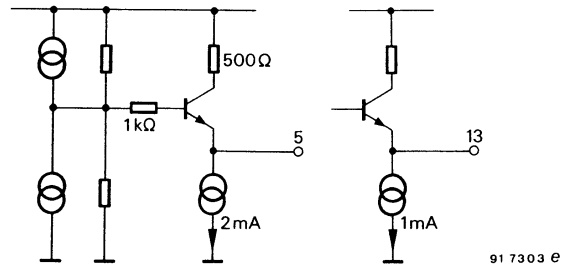

Figure 5. Pin 5 (13): Intercarrier output
Pin 5 = 5.74 MHz, Pin 13 = 5.5 MHz

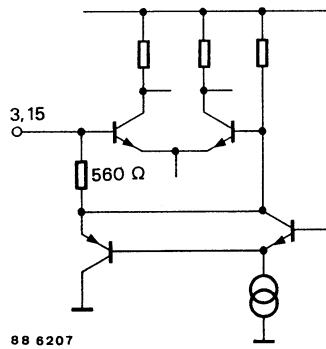

Figure 3. Pin 3 (15): Intercarrier input
Pin 3 = 5.74 MHz, Pin 15 = 5.5 MHz

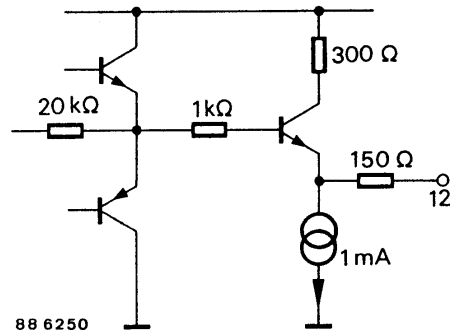

Figure 6. Pin 12: AF output 2

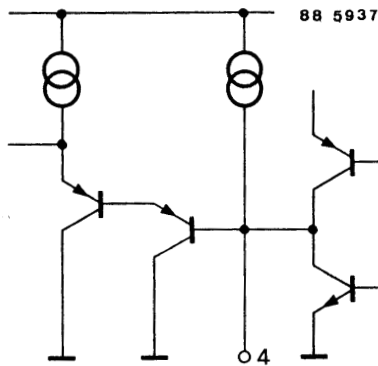

Figure 4. Pin 4: AGC storage capacitor

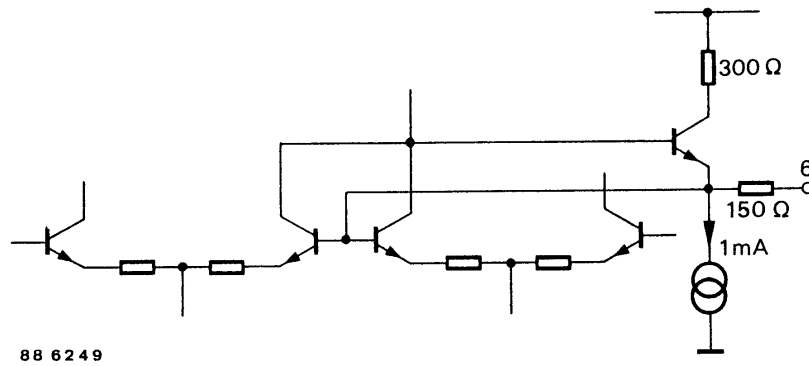

Figure 7. Pin 6: AF output 1

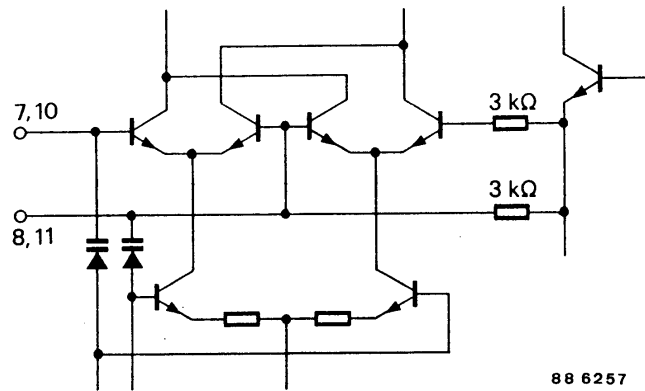

Figure 8. Pin 7, 8 (10, 11) FM demodulator circuit
Pin 7,8 = 5.74 MHz, Pin 10, 11 = 5.5 MHz

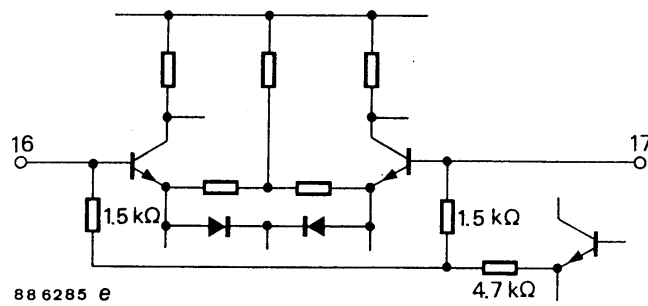

Figure 9. Pin 16, 17: IF input sound carrier

Ozone Depleting Substances Policy Statement

It is the policy of **TEMIC TELEFUNKEN microelectronic GmbH** to

1. Meet all present and future national and international statutory requirements.
2. Regularly and continuously improve the performance of our products, processes, distribution and operating systems with respect to their impact on the health and safety of our employees and the public, as well as their impact on the environment.

It is particular concern to control or eliminate releases of those substances into the atmosphere which are known as ozone depleting substances (ODSs).

The Montreal Protocol (1987) and its London Amendments (1990) intend to severely restrict the use of ODSs and forbid their use within the next ten years. Various national and international initiatives are pressing for an earlier ban on these substances.

TEMIC TELEFUNKEN microelectronic GmbH semiconductor division has been able to use its policy of continuous improvements to eliminate the use of ODSs listed in the following documents.

1. Annex A, B and list of transitional substances of the Montreal Protocol and the London Amendments respectively
2. Class I and II ozone depleting substances in the Clean Air Act Amendments of 1990 by the Environmental Protection Agency (EPA) in the USA
3. Council Decision 88/540/EEC and 91/690/EEC Annex A, B and C (transitional substances) respectively.

TEMIC can certify that our semiconductors are not manufactured with ozone depleting substances and do not contain such substances.

We reserve the right to make changes to improve technical design and may do so without further notice.

Parameters can vary in different applications. All operating parameters must be validated for each customer application by the customer. Should the buyer use TEMIC products for any unintended or unauthorized application, the buyer shall indemnify TEMIC against all claims, costs, damages, and expenses, arising out of, directly or indirectly, any claim of personal damage, injury or death associated with such unintended or unauthorized use.

TEMIC TELEFUNKEN microelectronic GmbH, P.O.B. 3535, D-74025 Heilbronn, Germany
Telephone: 49 (0)7131 67 2831, Fax number: 49 (0)7131 67 2423