

THIS DRAWING IS UNPUBLISHED  
 ALL RIGHTS RESERVED

REV	DATE	DESCRIPTION	BY	APP'D
AA	00			
B	02-07-2008			

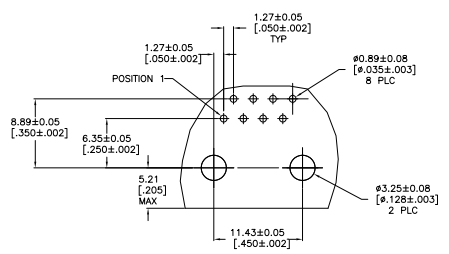
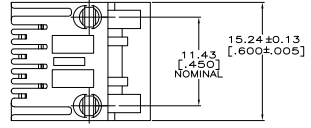
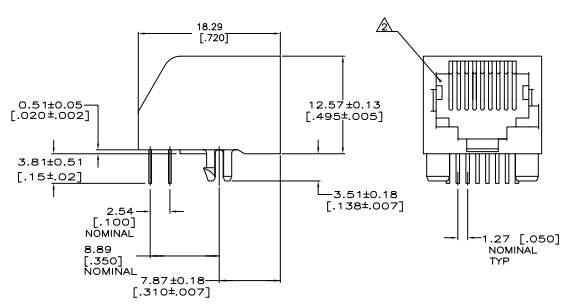

- MATERIAL: HOUSING – HTN MOLDING COMPOUND, UL 94V-0, COLOR: BLACK  
 TERMINAL – 0.36[.014] THICK PHOS BRONZE PLATED WITH 1.27μm[.000050] MINIMUM THICK HARD GOLD IN LOCALIZED GOLD PLATE AREA AND 3.81μm[.000150] MINIMUM THICK MATTE TIN IN SOLDER AREA OVER 1.27μm[.000050] MINIMUM THICK NICKEL UNDERPLATE.
- CAVITY CONFORMS TO FCC RULES AND REGULATIONS PART 68, SUBPART F.
- BULK PACKAGED IN A TRAY

5569118-1  
 PART NUMBER

THIS DRAWING IS A CONTROLLED DOCUMENT.		DESIGNED BY: J. FERNANDEZ	DESIGNED BY: J. FERNANDEZ	DATE: 02-07-2008	DATE: 02-07-2008
DRAWN BY: R. WESTMAN		CHECKED BY: R. WESTMAN	CHECKED BY: R. WESTMAN	DATE: 02-07-2008	DATE: 02-07-2008
PART NO: 108-1163		REV: 1	REV: 1	DATE: 02-07-2008	DATE: 02-07-2008
PART NO: 114-2048		REV: 1	REV: 1	DATE: 02-07-2008	DATE: 02-07-2008
SEE NOTE 1	SEE NOTE 1	CUSTOMER DRAWING	00779	5569118	1 1 1