

MIL-C-83517/1

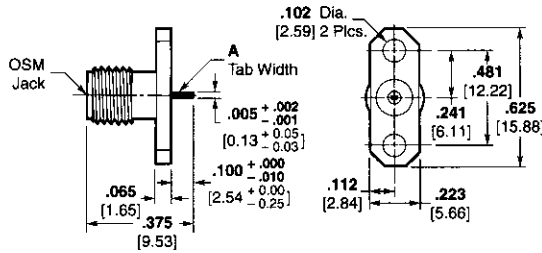

Outline 1

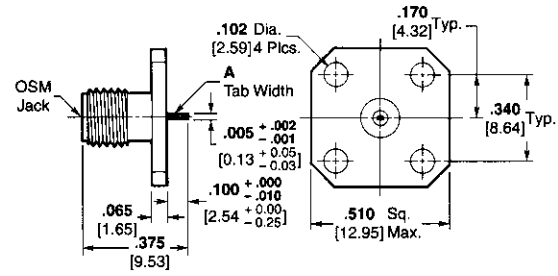

Outline 2

| Military Part No. | AMP Part No. | M/A-COM <sup>1</sup> Part No. (Ref. Only) | Outline | Dimension A              |
|-------------------|--------------|---|---------|--------------------------|
| -31001            | 1052928-1    | 2052-8003-92                              | 1       | .020 ±.002<br>0.51 ±.051 |
| -31002            | 1052930-1    | 2052-8004-92                              | 1       | .050 ±.001<br>1.27 ±.025 |
| -31003            | 1052932-1    | 2052-8005-92                              | 2       | .020 ±.002<br>0.51 ±.051 |
| -31004            | 1052934-1    | 2052-8006-92                              | 2       | .050 ±.001<br>1.27 ±.025 |

| Military Part No. | AMP Part No. | M/A-COM <sup>1</sup> Part No. (Ref. Only) | Outline | Dimension A              |
|-------------------|--------------|---|---------|--------------------------|
| -32001            | 1052927-1    | 2052-8003-90                              | 1       | .020 ±.002<br>0.51 ±.051 |
| -32002            | 1052929-1    | 2052-8004-90                              | 1       | .050 ±.001<br>1.27 ±.025 |
| -32003            | 1052931-1    | 2052-8005-90                              | 2       | .020 ±.002<br>0.51 ±.051 |
| -32004            | 1052933-1    | 2052-8006-90                              | 2       | .050 ±.001<br>1.27 ±.025 |

<sup>1</sup> -92 indicates passivated stainless steel finish.  
-90 indicates gold plated finish.

MIL-C-83517/2

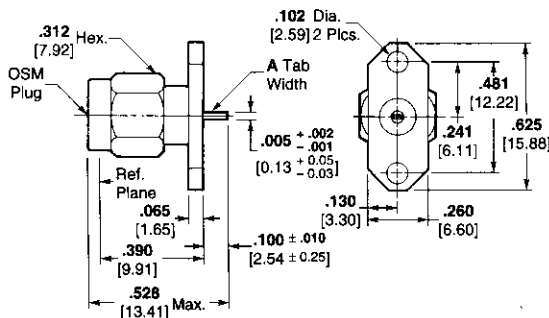

Outline 3

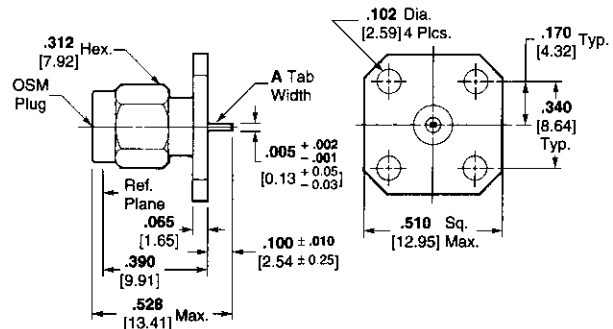

Outline 4

| Military Part No. | AMP Part No. | M/A-COM <sup>1</sup> Part No. (Ref. Only) | Outline | Dimension A              |
|-------------------|--------------|---|---------|--------------------------|
| -31001            | 1052409-1    | 2051-8001-92                              | 3       | .020 ±.002<br>0.51 ±.051 |
| -31002            | 1052411-1    | 2051-8002-92                              | 3       | .050 ±.001<br>1.27 ±.025 |
| -31003            | 1052413-1    | 2051-8003-92                              | 4       | .020 ±.002<br>0.51 ±.051 |
| -31004            | 1052415-1    | 2051-8004-92                              | 4       | .050 ±.001<br>1.27 ±.025 |

| Military Part No. | AMP Part No. | M/A-COM <sup>1</sup> Part No. (Ref. Only) | Outline | Dimension A              |
|-------------------|--------------|---|---------|--------------------------|
| -32001            | 1052408-1    | 2051-8001-90                              | 3       | .020 ±.002<br>0.51 ±.051 |
| -32002            | 1052410-1    | 2051-8002-90                              | 3       | .050 ±.001<br>1.27 ±.025 |
| -32003            | 1052412-1    | 2051-8003-90                              | 4       | .020 ±.002<br>0.51 ±.051 |
| -32004            | 1052414-1    | 2051-8004-90                              | 4       | .050 ±.001<br>1.27 ±.025 |

<sup>1</sup> -92 indicates passivated stainless steel finish.  
-90 indicates gold plated finish.