

TDA4865J; TDA4865AJ

Vertical deflection booster

Rev. 02 — 3 November 2006

Product data sheet

1. General description

The TDA4865J and TDA4865AJ are deflection boosters for use in vertical deflection systems for frame frequencies up to 200 Hz.

The TDA4865J needs a separate flyback supply voltage, so the supply voltages are independently adjustable to optimize power consumption and flyback time.

For the TDA4865AJ the flyback supply voltage will be generated internally by doubling the supply voltage and therefore a separate flyback supply voltage is not needed.

Both circuits provide differential input stages.

2. Features

- Power amplifier with differential inputs
- Output current up to 3.8 A (p-p)
- High vertical deflection frequency up to 200 Hz
- High linear sawtooth signal amplification
- Flyback generator:
 - ◆ TDA4865J: separate adjustable flyback supply voltage up to 70 V
 - ◆ TDA4865AJ: internally doubled supply voltage (two supply voltages only for DC-coupled outputs)

3. Quick reference data

Table 1. Quick reference data

Symbol	Parameter	Conditions	Min	Typ	Max	Unit
V _{P1}	supply voltage 1		9	-	35	V
V _{P2}	supply voltage 2		V _{P1} - 1	-	70	V
V _{FB}	flyback supply voltage of TDA4865J		V _{P1} - 1	-	70	V
V _{P3}	flyback generator output voltage of TDA4865AJ	I _{VOU} T = -1.9 A	0	-	V _{P1} + 2.2	V
V _{i(INN)}	input voltage on pin INN		1.6	-	V _{P1} - 0.5	V
V _{i(INP)}	input voltage on pin INP		1.6	-	V _{P1} - 0.5	V
I _{P1}	supply current 1	during scan	-	6	10	mA



Table 1. Quick reference data ...continued

Symbol	Parameter	Conditions	Min	Typ	Max	Unit
I_{P2}	quiescent supply current 2	$I_{VOUT} = 0$	-	25	60	mA
$I_{VOUT(p-p)}$	vertical deflection output current (peak-to-peak value)		-	-	3.8	A
T_{amb}	ambient temperature		-20	-	+75	°C

4. Ordering information

Table 2. Ordering information

Type number	Package		Version
	Name	Description	
TDA4865J	DBS7P	plastic DIL-bent-SIL power package; 7 leads	SOT524-1
TDA4865AJ		(lead length 12/11 mm); exposed die pad	

5. Block diagram

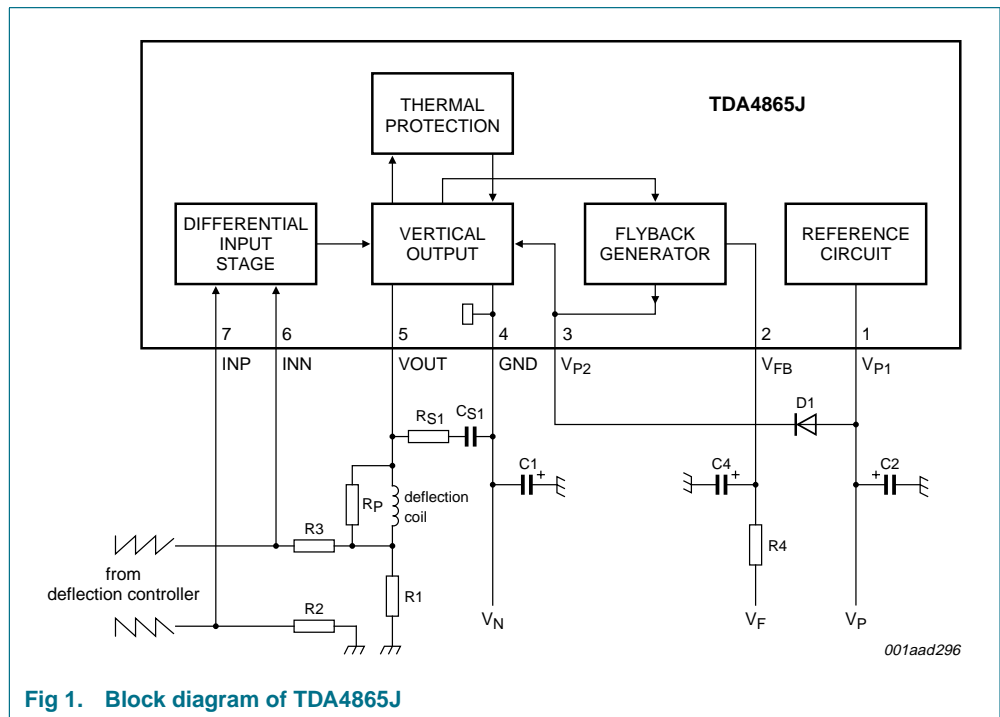
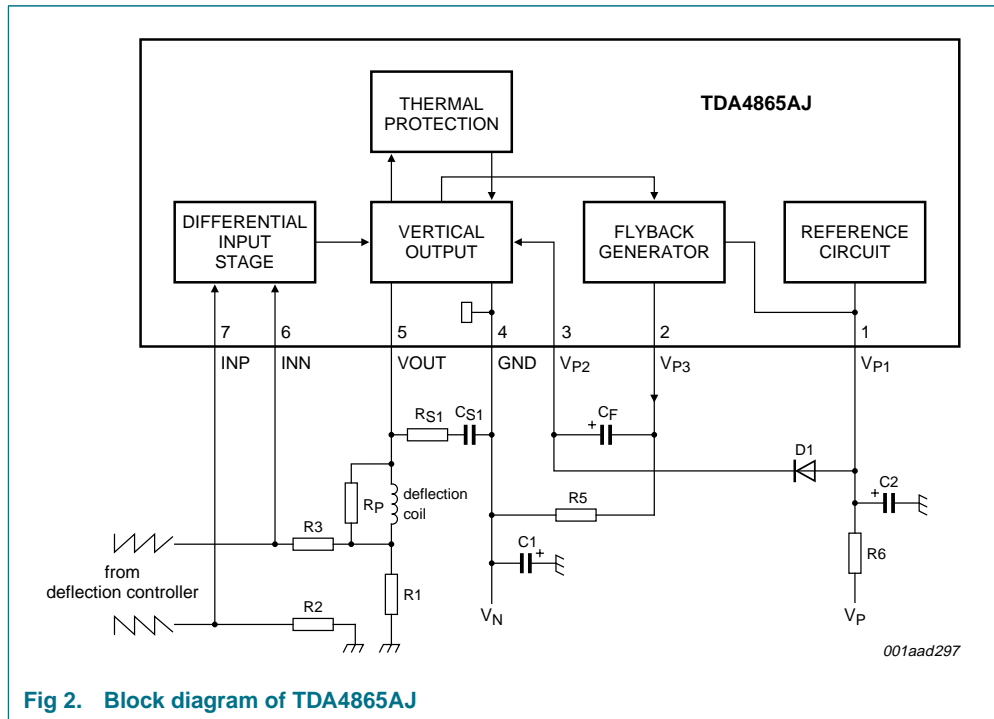
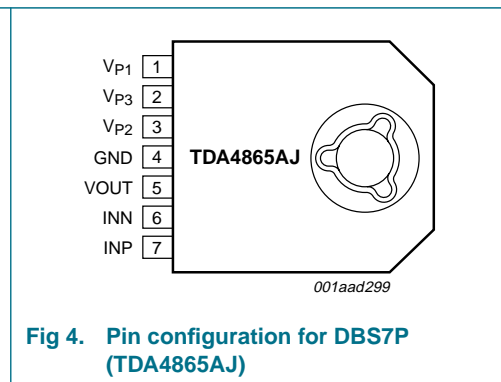
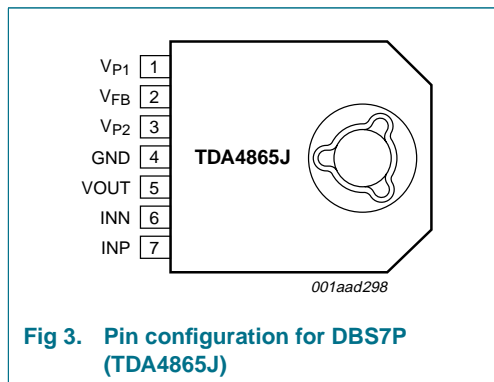

Fig 1. Block diagram of TDA4865J



6. Pinning information

6.1 Pinning



6.2 Pin description

Table 3. Pin description

Symbol	Pin		Description
	TDA4865J	TDA4865AJ	
V _{P1}	1	1	positive supply voltage 1
V _{FB}	2	-	flyback supply voltage
V _{P3}	-	2	flyback generator output
V _{P2}	3	3	supply voltage 2 for vertical output
GND	4	4	ground or negative supply voltage
VO _{UT}	5	5	vertical output
INN	6	6	inverted input of differential input stage
INP	7	7	non-inverted input of differential input stage

7. Functional description

Both the TDA4865J and TDA4865AJ consist of a differential input stage, a vertical output stage, a flyback generator, a reference circuit and a thermal protection circuit.

The TDA4865J operates with a separate flyback supply voltage (see [Figure 1](#)) while the TDA4865AJ generates the flyback voltage internally by doubling the supply voltage (see [Figure 2](#)).

7.1 Differential input stage

The differential sawtooth input current signal (from the deflection controller) is connected to the inputs (inverted signal to pin INN and non-inverted signal to pin INP). The vertical feedback signal is superimposed on the inverted signal on pin INN.

7.2 Vertical output and thermal protection

The vertical output stage is a quasi-complementary class-B amplifier with a high linearity.

The output stage is protected against thermal overshoots. For a junction temperature of $T_j > 150\text{ °C}$ the protection will be activated and will reduce the deflection current ($I_{VO\text{UT}}$).

7.3 Flyback generator

The flyback generator supplies the vertical output stage during flyback.

The TDA4865J is used with a separate flyback supply voltage to achieve a short flyback time with minimized power dissipation.

The TDA4865AJ needs a capacitor (C_F) connected between pins V_{P3} and V_{P2} (see [Figure 2](#)). Capacitor C_F is charged during scan, using the external diode D1 and resistor R5. During flyback the cathode of capacitor C_F is connected to the positive supply voltage and the flyback voltage is then twice the supply voltage. For the TDA4865AJ the resistor R6 in the positive supply line can be used to reduce the power consumption.

In parallel with the deflection coil a damping resistor R_P and an RC combination ($R_{S1} = 5.6 \Omega$ and $C_{S1} = 100 \text{ nF}$) are needed. Furthermore, another additional RC combination ($R_{S2} = 5.6 \Omega$ and $C_{S2} = 47 \text{ nF}$ to 150 nF) can be used to minimize the noise effect and the flyback time (see [Figure 7](#) and [Figure 8](#)).

8. Internal circuitry

Table 4. Internal circuits

Symbol	Pin	Equivalent circuit
TDA4865J		
V_{P1}	1	
V_{FB}	2	
V_{P2}	3	
GND	4	
VOUT	5	
INN	6	
INP	7	
TDA4865AJ		
V_{P1}	1	
V_{P3}	2	
V_{P2}	3	
GND	4	
VOUT	5	
INN	6	
INP	7	

9. Limiting values

Table 5. Limiting values

In accordance with the Absolute Maximum Rating System (IEC 60134). Voltages referenced to pin GND; unless otherwise specified.

Symbol	Parameter	Conditions	Min	Max	Unit	
V _{P1}	supply voltage 1		-	40	V	
V _{P2}	supply voltage 2		-	70	V	
V _{FB}	flyback supply voltage of TDA4865J		-	70	V	
V _{P3}	flyback generator output voltage of TDA4865AJ		0	V _{P1} + 3	V	
V _{i(INN)}	input voltage on pin INN		-	V _{P1}	V	
V _{i(INP)}	input voltage on pin INP		-	V _{P1}	V	
V _{o(VOUT)}	output voltage on pin VOUT		-	72	V	
I _{P2}	supply current 2		-	±2.0	A	
I _{o(VOUT)}	output current on pin VOUT		[1]	±2.0	A	
I _{VFB}	current during flyback of TDA4865J		-	±2.0	A	
I _{VP3}	current during flyback of TDA4865AJ		-	±2.0	A	
T _{stg}	storage temperature		-25	+150	°C	
T _{amb}	ambient temperature		-20	+75	°C	
T _j	junction temperature		[1]	150	°C	
V _{esd}	electrostatic discharge voltage	machine model	[2]	-400	+400	V
		human body model	[3]	-4000	+4000	V

[1] Internally limited by thermal protection; will be activated for T_j ≥ 150 °C.

[2] Class C according to EIA/JESD22-A115-A.

[3] Class 3A according to JESD22-A114C.01.

10. Thermal characteristics

Table 6. Thermal characteristics

Symbol	Parameter	Conditions	Typ	Unit
R _{th(j-mb)}	thermal resistance from junction to mounting base		[1] 4	K/W

[1] To minimize the thermal resistance from mounting base to heat sink [R_{th(mb-h)}] follow the recommended mounting instruction: screw mounting preferred; torque = 40 Ncm; use heat sink compound; isolation plate increases R_{th(mb-h)}.

11. Characteristics

Table 7. Characteristics

V_{P1} = 25 V; T_{amb} = 25 °C; voltages referenced to pin GND; unless otherwise specified.

Symbol	Parameter	Conditions	Min	Typ	Max	Unit
Supplies						
V _{P1}	supply voltage 1		9	-	35	V
V _{P2}	supply voltage 2		V _{P1} - 1	-	70	V
V _{FB}	flyback supply voltage of TDA4865J		V _{P1} - 1	-	70	V

Table 7. Characteristics ...continued $V_{P1} = 25\text{ V}$; $T_{amb} = 25\text{ }^\circ\text{C}$; voltages referenced to pin GND; unless otherwise specified.

Symbol	Parameter	Conditions	Min	Typ	Max	Unit
V_{P3}	flyback generator output voltage of TDA4865AJ	$I_{VOUT} = -1.9\text{ A}$	0	-	$V_{P1} + 2.2$	V
I_{P1}	supply current 1	during scan	-	6	10	mA
I_{P2}	quiescent supply current 2	$I_{VOUT} = 0$	-	25	60	mA
Differential input stage						
$V_{i(INN)}$	input voltage on pin INN		1.6	-	$V_{P1} - 0.5$	V
$V_{i(INP)}$	input voltage on pin INP		1.6	-	$V_{P1} - 0.5$	V
$I_{q(INN)}$	input quiescent current on pin INN		-	-100	-500	nA
$I_{q(INP)}$	input quiescent current on pin INP		-	-100	-500	nA
Flyback generator						
I_{VFB}	current during flyback of TDA4865J		-	-	± 1.9	A
I_{VP3}	current during flyback of TDA4865AJ		-	-	± 1.9	A
$V_{VP2-VFB(r)}$	reverse voltage drop during flyback of TDA4865J	$I_{VOUT} = -1\text{ A}$	-	-2	-	V
		$I_{VOUT} = -1.25\text{ A}$	-	-2.2	-	V
		$I_{VOUT} = -1.9\text{ A}$	-	-2.7	-	V
$V_{VP2-VFB(f)}$	forward voltage drop during flyback of TDA4865J	$I_{VOUT} = 1\text{ A}$	-	1.5	-	V
		$I_{VOUT} = 1.25\text{ A}$	-	1.7	-	V
		$I_{VOUT} = 1.9\text{ A}$	-	2.1	-	V
$V_{VP3-VP1(r)}$	reverse voltage drop during flyback of TDA4865AJ	$I_{VOUT} = -1\text{ A}$	-	-2	-	V
		$I_{VOUT} = -1.25\text{ A}$	-	-2.2	-	V
		$I_{VOUT} = -1.9\text{ A}$	-	-2.7	-	V
$V_{VP3-VP1(f)}$	forward voltage drop during flyback of TDA4865AJ	$I_{VOUT} = 1\text{ A}$	-	1.5	-	V
		$I_{VOUT} = 1.25\text{ A}$	-	1.7	-	V
		$I_{VOUT} = 1.9\text{ A}$	-	2.1	-	V
Vertical output stage; see Figure 5						
I_{VOUT}	vertical deflection output current		-	-	± 1.9	A
$I_{VOUT(p-p)}$	vertical deflection output current (peak-to-peak value)		-	-	3.8	A
$V_{o(sat)n}$	output saturation voltage to ground	$I_{VOUT} = 1\text{ A}$	-	1.3	1.7	V
		$I_{VOUT} = 1.25\text{ A}$	-	1.5	2.3	V
		$I_{VOUT} = 1.9\text{ A}$	-	2.6	3.0	V
$V_{o(sat)p}$	output saturation voltage to V_{P2}	$I_{VOUT} = 1\text{ A}$	-2.3	-2.0	-	V
		$I_{VOUT} = 1.25\text{ A}$	-2.8	-2.2	-	V
		$I_{VOUT} = 1.9\text{ A}$	-3.5	-2.6	-	V
LIN	non-linearity of output signal		[1]	-	1	%

[1] Deviation of the output slope at a constant input slope.

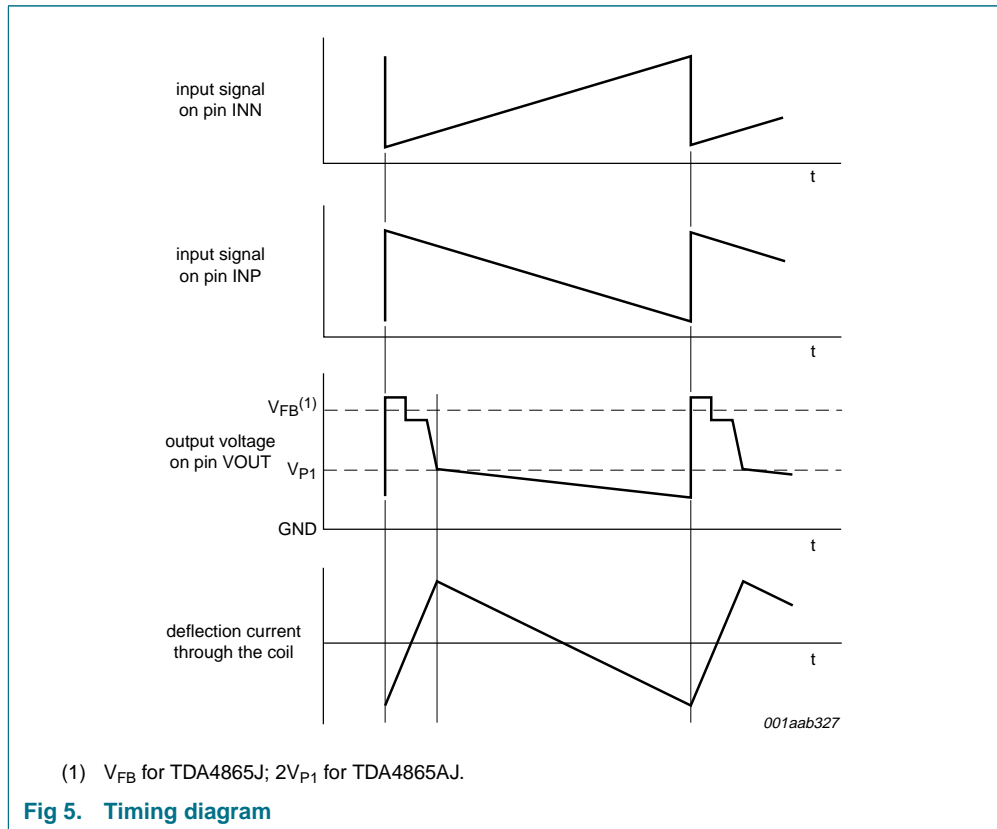

12. Application information

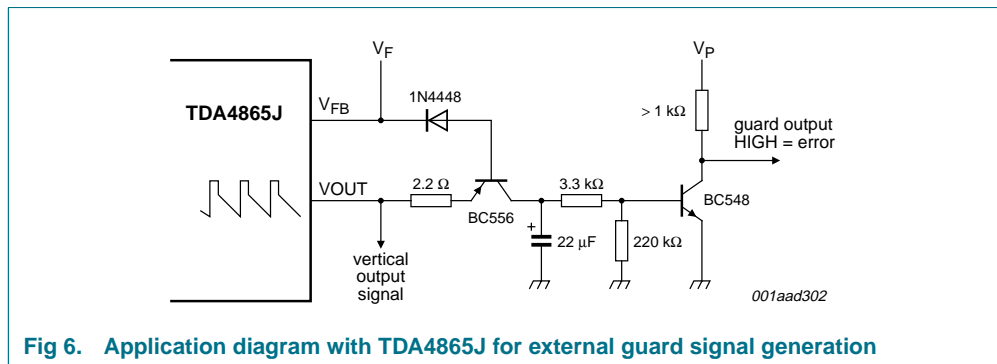

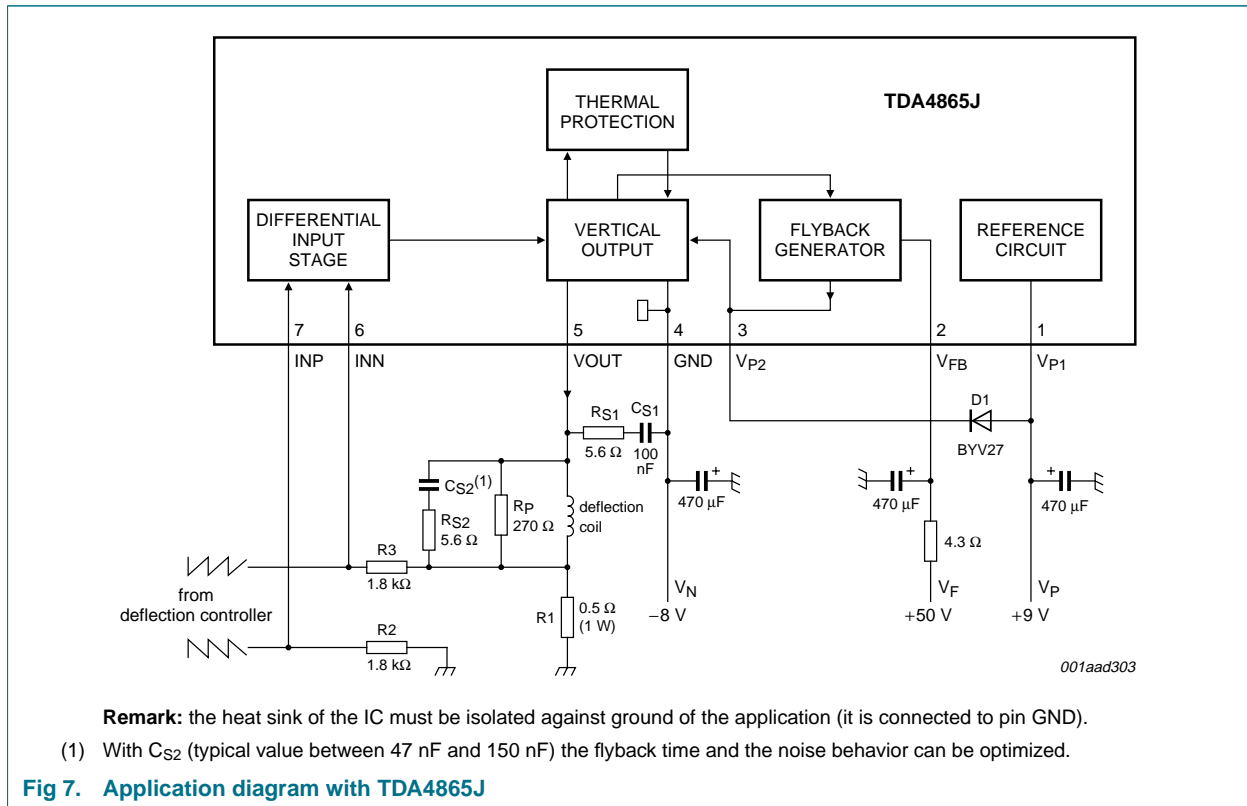

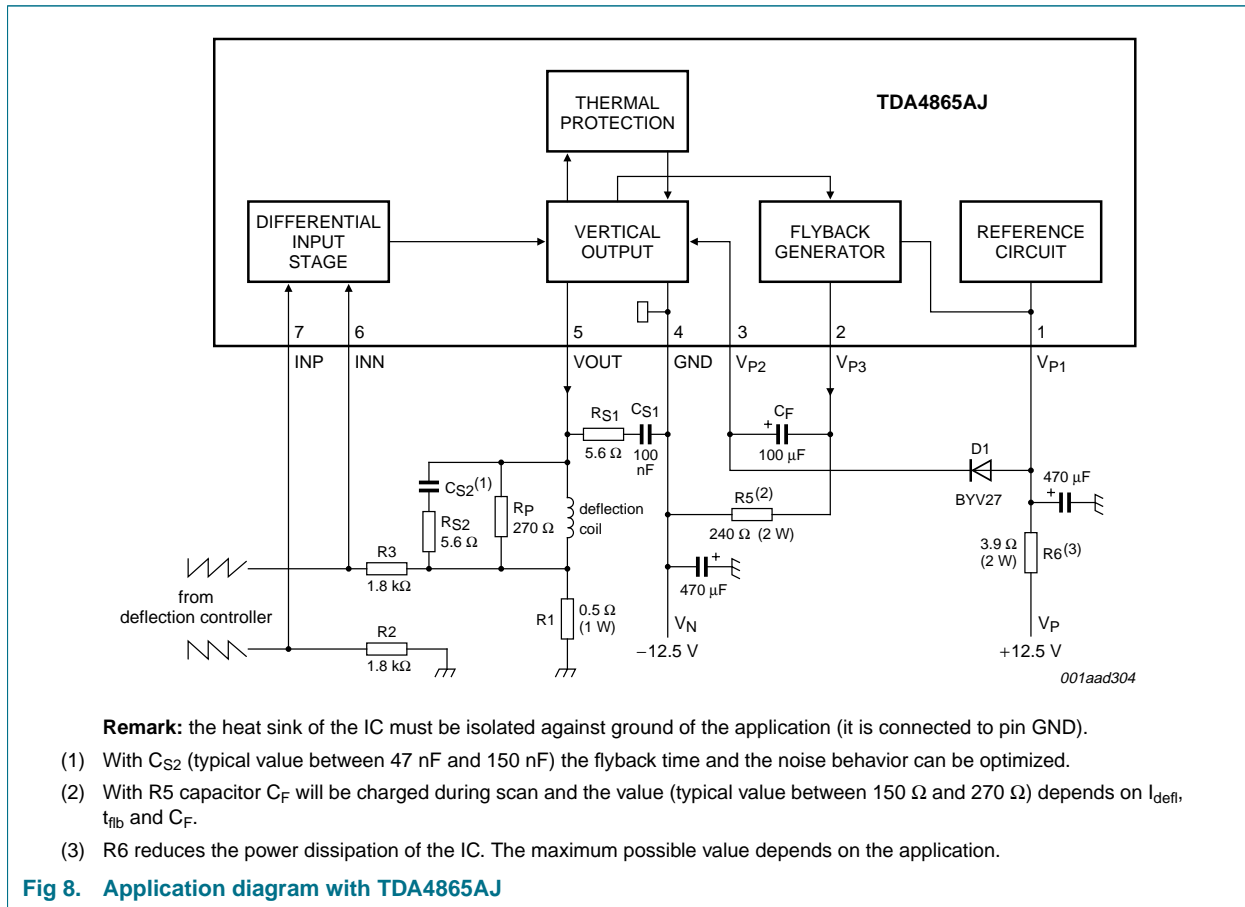

12.1 Example for both TDA4865J and TDA4865AJ

Table 8. Values given from application

Symbol	Value	Unit
$I_{defl(max)(M)}$	1.6 (peak value)	A
$L_{deflcoil}$	10	mH
$R_{deflcoil}$	4	Ω
R_p	270	Ω
R_1	0.5	Ω
R_2	1.8	k Ω
R_3	1.8	k Ω
V_F ^[1]	50	V
T_{amb}	50	$^{\circ}C$
$T_{deflcoil}$	75	$^{\circ}C$
$R_{th(j-mb)}$	4	K/W
$R_{th(mb-h)}$	0.5	K/W
$R_{th(h-a)}$	2	K/W

[1] Flyback voltage measured against 0 V; for TDA4865J only.

Table 9. Calculated values

Symbol	Value		Unit
	TDA4865J	TDA4865AJ	
V _{P1}	8	15	V
V _N	-13	-15	V
P _{tot}	8.5	12.1	W
P _{defl}	3.85	3.85	W
P _{IC}	4.65	8.25	W
R _{th(tot)(max)}	12.9	7.27	K/W
T _{j(max)} ^[1]	93	103.6	°C
t _{flb}	650	720	µs

[1] With a heat sink of 2 K/W.

V_{P1}, V_N and V_{FB} are referenced to ground of application; voltages are calculated with +10 % tolerances.

The calculation formulae for supply voltages are as follows:

$$V_{P1} = -V_{o(sat)p} + (RI + R_{deflcoil}) \times I_{defl(max)} - U'_L + U_{D1} \quad (1)$$

$$|V_N| = V_{o(sat)n} + (RI + R_{deflcoil}) \times I_{defl(max)} + U'_L \quad (2)$$

where:

$$U'_L = L_{deflcoil} \times 2I_{defl(max)} \times f_v$$

f_v = vertical deflection frequency

U_{D1} = forward voltage drop across D1

The calculation formulae for power consumption is:

$$P_{IC} = P_{tot} - P_{defl} \quad (3)$$

$$P_{tot} = (V_{P1} - U_{D1}) \times \frac{I_{defl(max)}}{4} + |V_N| \times \frac{I_{defl(max)}}{4} + (V_{P1} + |V_N|) \times 0.01 + 0.2 \quad (4)$$

$$P_{defl} = \frac{R_{deflcoil} + RI}{3} \times I_{defl(max)}^2 \quad (5)$$

where:

P_{IC} = power dissipation of the IC

P_{tot} = total power dissipation

P_{defl} = power dissipation of the deflection coil

Calculation formulae for maximum required thermal resistance for the heat sink at T_{j(max)} = 110 °C:

$$R_{th(tot)} = R_{th(j-mb)} + R_{th(mb-h)} + R_{th(h-a)} \quad (6)$$

$$R_{th(h-a)} = \frac{T_{j(max)} - T_{amb}}{P_{IC}} - R_{th(j-mb)} - R_{th(mb-h)} \quad (7)$$

Calculation formulae for flyback time (for TDA4865J only):

$$t_{flb} = \frac{L_{deflcoil}}{R_{deflcoil} + R1} \times \ln \left(\frac{V_F + (R_{deflcoil} + R1) \times I_{defl(max)}}{V_F - (R_{deflcoil} + R1) \times I_{defl(max)}} \right) \tag{8}$$

where:

V_F measured against 0 V

12.2 Application example for different driver circuits

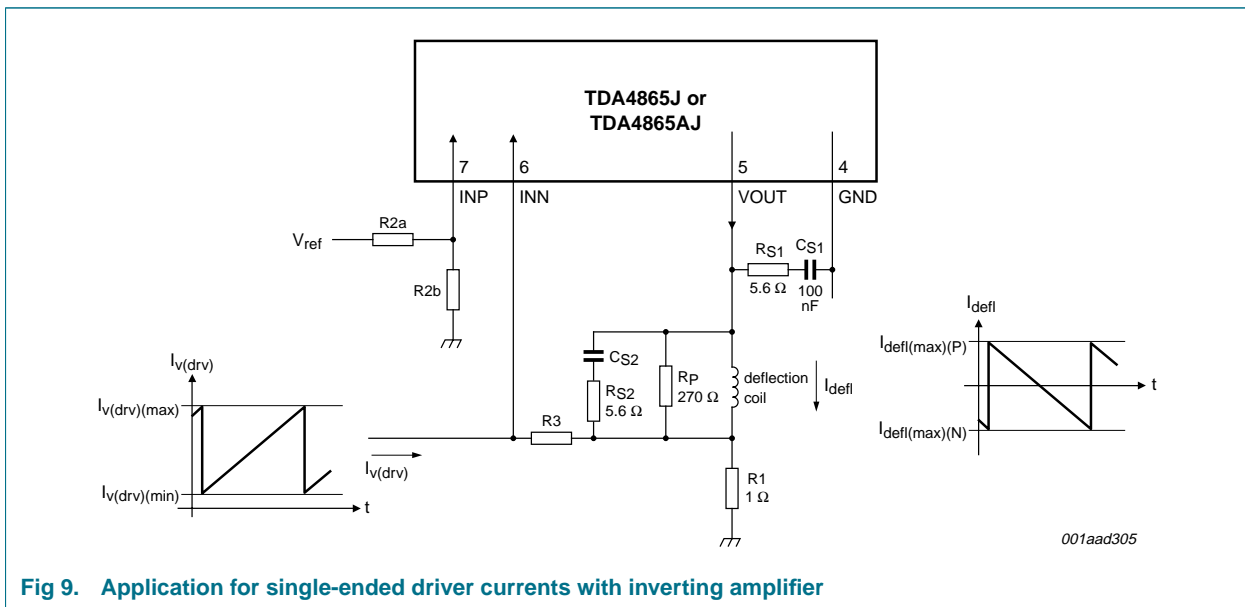

Fig 9. Application for single-ended driver currents with inverting amplifier

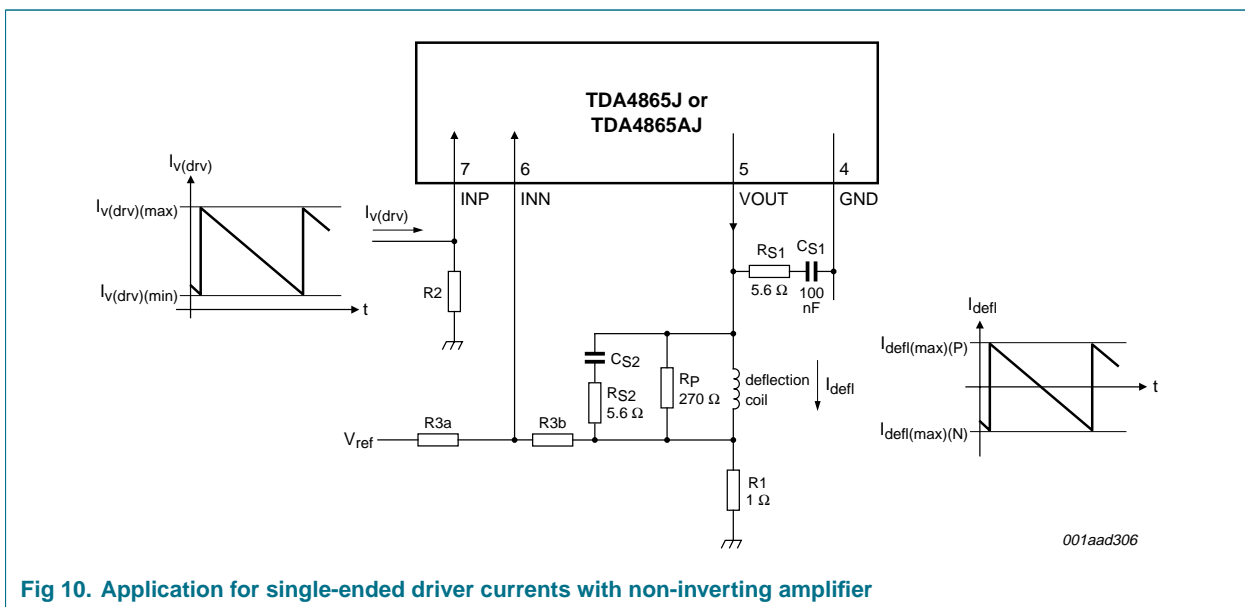

Fig 10. Application for single-ended driver currents with non-inverting amplifier

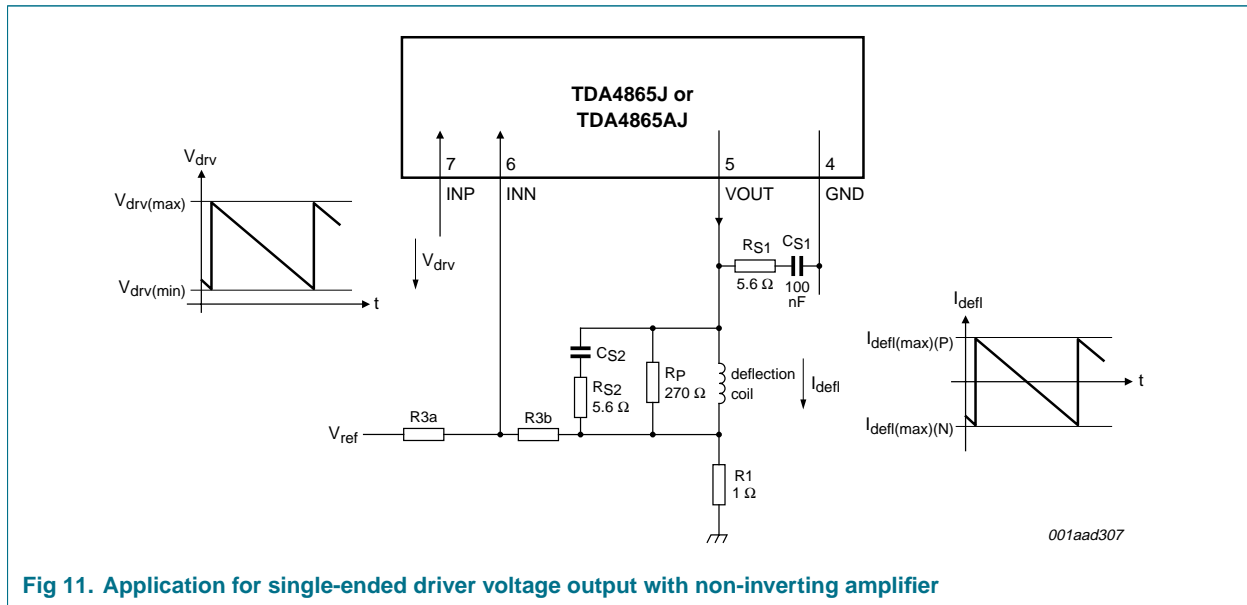

Fig 11. Application for single-ended driver voltage output with non-inverting amplifier

13. Package outline

DBS7P: plastic DIL-bent-SIL power package; 7 leads (lead length 12/11 mm); exposed die pad SOT524-1

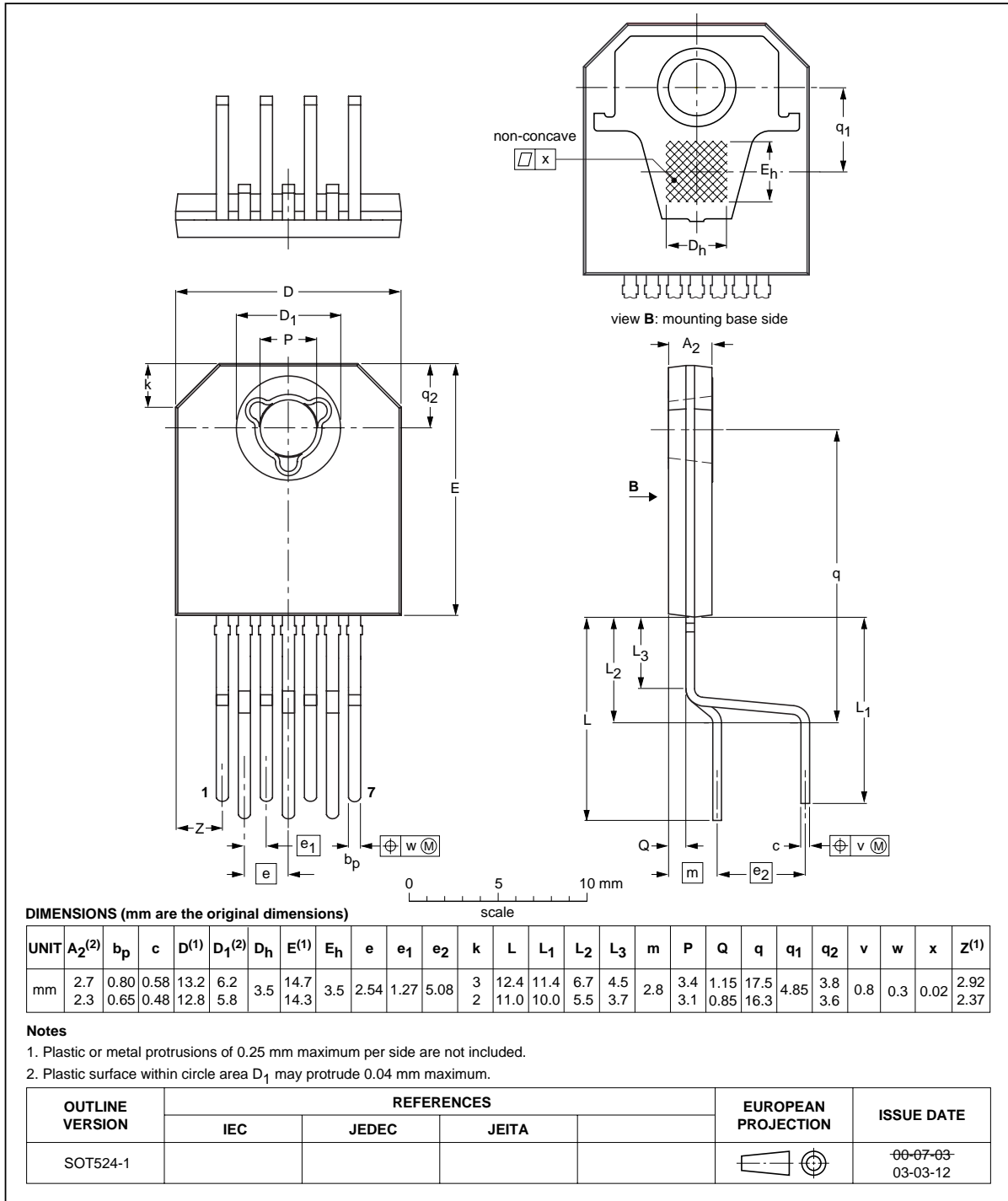

Fig 12. Package outline SOT524-1 (DBS7P)

14. Soldering

14.1 Introduction to soldering through-hole mount packages

This text gives a brief insight to wave, dip and manual soldering.

Wave soldering is the preferred method for mounting of through-hole mount IC packages on a printed-circuit board.

14.2 Soldering by dipping or by solder wave

Driven by legislation and environmental forces the worldwide use of lead-free solder pastes is increasing. Typical dwell time of the leads in the wave ranges from 3 seconds to 4 seconds at 250 °C or 265 °C, depending on solder material applied, SnPb or Pb-free respectively.

The total contact time of successive solder waves must not exceed 5 seconds.

The device may be mounted up to the seating plane, but the temperature of the plastic body must not exceed the specified maximum storage temperature ($T_{stg(max)}$). If the printed-circuit board has been pre-heated, forced cooling may be necessary immediately after soldering to keep the temperature within the permissible limit.

14.3 Manual soldering

Apply the soldering iron (24 V or less) to the lead(s) of the package, either below the seating plane or not more than 2 mm above it. If the temperature of the soldering iron bit is less than 300 °C it may remain in contact for up to 10 seconds. If the bit temperature is between 300 °C and 400 °C, contact may be up to 5 seconds.

14.4 Package related soldering information

Table 10. Suitability of through-hole mount IC packages for dipping and wave soldering

Package	Soldering method	
	Dipping	Wave
CPGA, HCPGA	-	suitable
DBS, DIP, HDIP, RDBS, SDIP, SIL	suitable	suitable ^[1]
PMFP ^[2]	-	not suitable

[1] For SDIP packages, the longitudinal axis must be parallel to the transport direction of the printed-circuit board.

[2] For PMFP packages hot bar soldering or manual soldering is suitable.

15. Revision history

Table 11. Revision history

Document ID	Release date	Data sheet status	Change notice	Supersedes
TDA4865J_TDA4865AJ_2	20061103	Product data sheet	-	TDA4865_1
Modifications:		<ul style="list-style-type: none">The format of this data sheet has been redesigned to comply with the new identity guidelines of NXP SemiconductorsLegal texts have been adapted to the new company name where appropriate		
TDA4865_1	19921208	Preliminary specification	-	-

16. Legal information

16.1 Data sheet status

Document status ^{[1][2]}	Product status ^[3]	Definition
Objective [short] data sheet	Development	This document contains data from the objective specification for product development.
Preliminary [short] data sheet	Qualification	This document contains data from the preliminary specification.
Product [short] data sheet	Production	This document contains the product specification.

[1] Please consult the most recently issued document before initiating or completing a design.

[2] The term 'short data sheet' is explained in section "Definitions".

[3] The product status of device(s) described in this document may have changed since this document was published and may differ in case of multiple devices. The latest product status information is available on the Internet at URL <http://www.nxp.com>.

16.2 Definitions

Draft — The document is a draft version only. The content is still under internal review and subject to formal approval, which may result in modifications or additions. NXP Semiconductors does not give any representations or warranties as to the accuracy or completeness of information included herein and shall have no liability for the consequences of use of such information.

Short data sheet — A short data sheet is an extract from a full data sheet with the same product type number(s) and title. A short data sheet is intended for quick reference only and should not be relied upon to contain detailed and full information. For detailed and full information see the relevant full data sheet, which is available on request via the local NXP Semiconductors sales office. In case of any inconsistency or conflict with the short data sheet, the full data sheet shall prevail.

16.3 Disclaimers

General — Information in this document is believed to be accurate and reliable. However, NXP Semiconductors does not give any representations or warranties, expressed or implied, as to the accuracy or completeness of such information and shall have no liability for the consequences of use of such information.

Right to make changes — NXP Semiconductors reserves the right to make changes to information published in this document, including without limitation specifications and product descriptions, at any time and without notice. This document supersedes and replaces all information supplied prior to the publication hereof.

Suitability for use — NXP Semiconductors products are not designed, authorized or warranted to be suitable for use in medical, military, aircraft, space or life support equipment, nor in applications where failure or

malfunction of a NXP Semiconductors product can reasonably be expected to result in personal injury, death or severe property or environmental damage. NXP Semiconductors accepts no liability for inclusion and/or use of NXP Semiconductors products in such equipment or applications and therefore such inclusion and/or use is at the customer's own risk.

Applications — Applications that are described herein for any of these products are for illustrative purposes only. NXP Semiconductors makes no representation or warranty that such applications will be suitable for the specified use without further testing or modification.

Limiting values — Stress above one or more limiting values (as defined in the Absolute Maximum Ratings System of IEC 60134) may cause permanent damage to the device. Limiting values are stress ratings only and operation of the device at these or any other conditions above those given in the Characteristics sections of this document is not implied. Exposure to limiting values for extended periods may affect device reliability.

Terms and conditions of sale — NXP Semiconductors products are sold subject to the general terms and conditions of commercial sale, as published at <http://www.nxp.com/profile/terms>, including those pertaining to warranty, intellectual property rights infringement and limitation of liability, unless explicitly otherwise agreed to in writing by NXP Semiconductors. In case of any inconsistency or conflict between information in this document and such terms and conditions, the latter will prevail.

No offer to sell or license — Nothing in this document may be interpreted or construed as an offer to sell products that is open for acceptance or the grant, conveyance or implication of any license under any copyrights, patents or other industrial or intellectual property rights.

16.4 Trademarks

Notice: All referenced brands, product names, service names and trademarks are the property of their respective owners.

17. Contact information

For additional information, please visit: <http://www.nxp.com>

For sales office addresses, send an email to: salesaddresses@nxp.com

18. Contents

1	General description	1
2	Features	1
3	Quick reference data	1
4	Ordering information	2
5	Block diagram	2
6	Pinning information	3
6.1	Pinning	3
6.2	Pin description	4
7	Functional description	4
7.1	Differential input stage	4
7.2	Vertical output and thermal protection	4
7.3	Flyback generator	4
8	Internal circuitry	5
9	Limiting values	6
10	Thermal characteristics	6
11	Characteristics	6
12	Application information	8
12.1	Example for both TDA4865J and TDA4865AJ	10
12.2	Application example for different driver circuits	12
13	Package outline	14
14	Soldering	15
14.1	Introduction to soldering through-hole mount packages	15
14.2	Soldering by dipping or by solder wave	15
14.3	Manual soldering	15
14.4	Package related soldering information	15
15	Revision history	16
16	Legal information	17
16.1	Data sheet status	17
16.2	Definitions	17
16.3	Disclaimers	17
16.4	Trademarks	17
17	Contact information	17
18	Contents	18

Please be aware that important notices concerning this document and the product(s) described herein, have been included in section 'Legal information'.



© NXP B.V. 2006.

All rights reserved.

For more information, please visit: <http://www.nxp.com>

For sales office addresses, please send an email to: salesaddresses@nxp.com

Date of release: 3 November 2006

Document identifier: TDA4865J_TDA4865AJ_2