

## Product Brief

# TC358766 Display Bridge for DisplayPort™ Connectivity

### Highlights

- Display bridge for connectivity of DisplayPort™ panels to the Application Processors with a Mobile Industry Processor Interface (MIPI) Display Serial Interface (DSI) or Display Pixel Interface (DPI).
- Solutions based on the latest versions of the industry standard MIPI DSI 1.01 to ensure high speed data rates of up to 1 Gbps per lane and MIPI DPI 2.0 to ensure speed of 154 MHz.
- Display port transmitter features VESA DisplayPort 1.1a standard that supports 1.62 or 2.7 Gbps per lane; and configurable to single or dual lane per Main Link.
- Supports high-resolution DisplayPort panels up to WUXGA 1920 x 1200 at refresh rates of 60 fps.
- Applicable to products such as tablets, eBooks, netbooks and laptops.

### Description

The Toshiba TC358766 display bridge is optimized for handheld devices using a Host Processor with Mobile Industry Processor Interface (MIPI) Display Serial Interface (DSI) or Display Pixel Interface (DPI) connectivity. The TC358766 functions as a protocol bridge enabling the video stream from the Host Processor DSI link or DPI link to drive a single or two independent DisplayPort panel(s). The TC358766 has a DSI receiver that can be configured to support up to four DSI lanes with data rates up to 1 Gbps per lane, for maximum total bandwidth of 4 Gbps. It also has a DPI receiver that can be configured to support 16, 18 or 24 bits parallel interfaces and can be operated up to 154 MHz parallel clock. The DisplayPort transmitter can be configured to support a single Main Link with one or 2 lanes or dual Main Links with single lane per link. The data throughput is 1.62 Gbps or 2.7 Gbps per lane of the DisplayPort Main Link.

As the DisplayPort interface uses fewer lines and power consumption is more efficient, availability and usage of highresolution DisplayPort panels is becoming a feature in handheld applications such as tablets and netbooks. The Toshiba TC358766 display bridge can support displays with resolution up to 1920 x 1200 (WUXGA) at 24 bits per pixel, at refresh rate of 60 frames per second. The TC358766 can support both an embedded DisplayPort panel (eDP) or an external DP panel at one time or simultaneously. The TC358766 bridge supports audio streaming from the Application Processor through the I<sup>2</sup>S interface. The audio is transmitted through the DisplayPort link if the application requires, i.e. connecting to an external panel.

The TC358766 is a 120-pin device, in a small package size of 6 mm x 6 mm, 0.50 mm ball pitch designed for portable products.

### TC358766XBG System Block Diagram

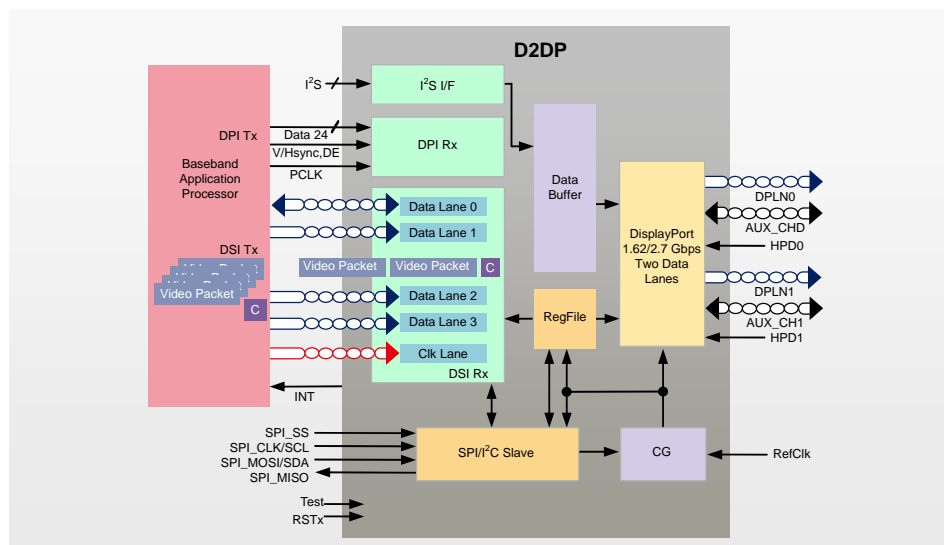

**Features****DSI Receiver**

- MIPI DSI: v1.01 / MIPI D-PHY: v1.0 compliant.
- Up to four (4) data lanes with bi-directional support on Data Lane 0.
- Maximum speed at 1 Gbps/lane.
- Video input data formats:
  - RGB-565, RGB-666 and RGB-888.
  - New DSI V1.02 data type support: 16-bit YCbCr 422
- Interlaced video mode is not supported.

**DPI Receiver**

- Maximum speed at 154 MHz.
- Video input data formats: RGB-565, RGB-666 and RGB-888.

**I<sup>2</sup>S Audio Interface**

- Supports sampling frequencies of 32, 44.1, 48, 88.2, 96, 176.4 & 192 KHz.
- Supports up to 2 audio channels.
- Optionally inserts IEC60958 status bits and preamble bits per channel.

**DisplayPort Interface**

- High-speed serial bridge chip using VESA DisplayPort 1.1a standard.
- Supports one dual-lane port for high bandwidth application or two single-lane ports for connection to two DisplayPort panels.

- Supports 1.62 or 2.7 Gbps/lane data rate with voltage swings @0.4, 0.6, 0.8 or 1.2V
- Support of pre-emphasis levels of 0, 3.5 dB and 6 dB.
- AUX channel supported at 1 Mbps.
- Supports HDCP encryption Version 1.3 Amendment for DisplayPort Revision 1.1.
- SSCG with ~30 KHz modulation to reduce EMI.

**I<sup>2</sup>C Interface**

- I<sup>2</sup>C slave interface for debugging and/or chip register set access.

**SPI Interface**

- SPI slave interface for chip register set access.
- SPI interface support for up to 30 MHz operation.

**Clock Source**

- DisplayPort clock source can be derived from an external clock input or from the DSI clock. Acceptable clock values from external source or DSI clock derivatives are 13, 26, 19.2 or 38.4 MHz.

**Power Supply Inputs**

- Core and MIPI D-PHY: 1.2V
- Digital I/O: 1.8V
- DisplayPort PHY and PLL: 1.8V and 1.2V

**Package**

- TC358766XBG: 120-pin, 6.0 mm x 6.0 mm, 0.5 mm ball pitch, 1.0 mm height

**Sales Offices****North America****Toshiba America Electronic Components Inc**

Irvine, CA                      San Jose, CA  
TEL: (949) 623-2900        TEL: (408) 526-2400

**ASIA****Toshiba Electronics (Shanghai) Co.,Ltd**

Shanghai, China              Shenzhen, China  
TEL: (021) 6139-3888        TEL: (0755) 2399-6897

**Toshiba Electronics Asia(Singapore) Pte. Ltd.**

TEL: (6278) 5252

**Toshiba Electronics Korea Corp.**

Seoul  
TEL: (02) 3484-4334

**Europe****Toshiba Electronics Europe GmbH**

Düsseldorf, Germany              Puteaux Cedex, France  
TEL: (0211) 5296-0                  TEL: (1) 47282181  
Farnborough, Hampshire, U.K.  
TEL: (0870) 060-2370

**Toshiba Electronics Asia Ltd**

Hong Kong  
TEL:2375-6111

**Toshiba Electronics Taiwan Corp.**

Taipei City  
TEL: (02) 2508-9988:

## RESTRICTIONS ON PRODUCT USE

- Toshiba Corporation, and its subsidiaries and affiliates (collectively "TOSHIBA"), reserve the right to make changes to the information in this document, and related hardware, software and systems (collectively "Product") without notice.
- This document and any information herein may not be reproduced without prior written permission from TOSHIBA. Even with TOSHIBA's written permission, reproduction is permissible only if reproduction is without alteration/omission.
- Though TOSHIBA works continually to improve Product's quality and reliability, Product can malfunction or fail. Customers are responsible for complying with safety standards and for providing adequate designs and safeguards for their hardware, software and systems which minimize risk and avoid situations in which a malfunction or failure of Product could cause loss of human life, bodily injury or damage to property, including data loss or corruption. Before customers use the Product, create designs including the Product, or incorporate the Product into their own applications, customers must also refer to and comply with (a) the latest versions of all relevant TOSHIBA information, including without limitation, this document, the specifications, the data sheets and application notes for Product and the precautions and conditions set forth in the "TOSHIBA Semiconductor Reliability Handbook" and (b) the instructions for the application with which the Product will be used with or for. Customers are solely responsible for all aspects of their own product design or applications, including but not limited to (a) determining the appropriateness of the use of this Product in such design or applications; (b) evaluating and determining the applicability of any information contained in this document, or in charts, diagrams, programs, algorithms, sample application circuits, or any other referenced documents; and (c) validating all operating parameters for such designs and applications. **TOSHIBA ASSUMES NO LIABILITY FOR CUSTOMERS' PRODUCT DESIGN OR APPLICATIONS.**
- Product is intended for use in general electronics applications (e.g., computers, personal equipment, office equipment, measuring equipment, industrial robots and home electronics appliances) or for specific applications as expressly stated in this document. Product is neither intended nor warranted for use in equipment or systems that require extraordinarily high levels of quality and/or reliability and/or a malfunction or failure of which may cause loss of human life, bodily injury, serious property damage or serious public impact ("Unintended Use"). Unintended Use includes, without limitation, equipment used in nuclear facilities, equipment used in the aerospace industry, medical equipment, equipment used for automobiles, trains, ships and other transportation, traffic signaling equipment, equipment used to control combustions or explosions, safety devices, elevators and escalators, devices related to electric power, and equipment used in finance-related fields. Do not use Product for Unintended Use unless specifically permitted in this document.
- Do not disassemble, analyze, reverse-engineer, alter, modify, translate or copy Product, whether in whole or in part.
- Product shall not be used for or incorporated into any products or systems whose manufacture, use, or sale is prohibited under any applicable laws or regulations.
- The information contained herein is presented only as guidance for Product use. No responsibility is assumed by TOSHIBA for any infringement of patents or any other intellectual property rights of third parties that may result from the use of Product. No license to any intellectual property right is granted by this document, whether express or implied, by estoppel or otherwise.
- **ABSENT A WRITTEN SIGNED AGREEMENT, EXCEPT AS PROVIDED IN THE RELEVANT TERMS AND CONDITIONS OF SALE FOR PRODUCT, AND TO THE MAXIMUM EXTENT ALLOWABLE BY LAW, TOSHIBA (1) ASSUMES NO LIABILITY WHATSOEVER, INCLUDING WITHOUT LIMITATION, INDIRECT, CONSEQUENTIAL, SPECIAL, OR INCIDENTAL DAMAGES OR LOSS, INCLUDING WITHOUT LIMITATION, LOSS OF PROFITS, LOSS OF OPPORTUNITIES, BUSINESS INTERRUPTION AND LOSS OF DATA, AND (2) DISCLAIMS ANY AND ALL EXPRESS OR IMPLIED WARRANTIES AND CONDITIONS RELATED TO SALE, USE OF PRODUCT, OR INFORMATION, INCLUDING WARRANTIES OR CONDITIONS OF MERCHANTABILITY, FITNESS FOR A PARTICULAR PURPOSE, ACCURACY OF INFORMATION, OR NONINFRINGEMENT.**
- Do not use or otherwise make available Product or related software or technology for any military purposes, including without limitation, for the design, development, use, stockpiling or manufacturing of nuclear, chemical, or biological weapons or missile technology products (mass destruction weapons). Product and related software and technology may be controlled under the Japanese Foreign Exchange and Foreign Trade Law and the U.S. Export Administration Regulations. Export and re-export of Product or related software or technology are strictly prohibited except in compliance with all applicable export laws and regulations.
- Please contact your TOSHIBA sales representative for details as to environmental matters such as the RoHS compatibility of Product. Please use Product in compliance with all applicable laws and regulations that regulate the inclusion or use of controlled substances, including without limitation, the EU RoHS Directive. TOSHIBA assumes no liability for damages or losses occurring as a result of noncompliance with applicable laws and regulations.