

Notice for TAIYO YUDEN products

Please read this notice before using the TAIYO YUDEN products.

REMINDERS

- Product information in this catalog is as of October 2009. All of the contents specified herein are subject to change without notice due to technical improvements, etc. Therefore, please check for the latest information carefully before practical application or usage of the Products.

Please note that Taiyo Yuden Co., Ltd. shall not be responsible for any defects in products or equipment incorporating such products, which are caused under the conditions other than those specified in this catalog or individual specification.

- Please contact Taiyo Yuden Co., Ltd. for further details of product specifications as the individual specification is available.
- Please conduct validation and verification of products in actual condition of mounting and operating environment before commercial shipment of the equipment.
- All electronic components or functional modules listed in this catalog are developed, designed and intended for use in general electronics equipment.(for AV, office automation, household, office supply, information service, telecommunications, (such as mobile phone or PC) etc.). Before incorporating the components or devices into any equipment in the field such as transportation,(automotive control, train control, ship control), transportation signal, disaster prevention, medical, public information network (telephone exchange, base station) etc. which may have direct influence to harm or injure a human body, please contact Taiyo Yuden Co., Ltd. for more detail in advance. Do not incorporate the products into any equipment in fields such as aerospace, aviation, nuclear control, submarine system, military, etc. where higher safety and reliability are especially required.

In addition, even electronic components or functional modules that are used for the general electronic equipment, if the equipment or the electric circuit require high safety or reliability function or performances, a sufficient reliability evaluation check for safety shall be performed before commercial shipment and moreover, due consideration to install a protective circuit is strongly recommended at customer's design stage.

- The contents of this catalog are applicable to the products which are purchased from our sales offices or distributors (so called "TAIYO YUDEN' s official sales channel"). It is only applicable to the products purchased from any of TAIYO YUDEN' s official sales channel.
- Please note that Taiyo Yuden Co., Ltd. shall have no responsibility for any controversies or disputes that may occur in connection with a third party's intellectual property rights and other related rights arising from your usage of products in this catalog. Taiyo Yuden Co., Ltd. grants no license for such rights.
- Caution for export**
Certain items in this catalog may require specific procedures for export according to "Foreign Exchange and Foreign Trade Control Law" of Japan, "U.S. Export Administration Regulations", and other applicable regulations. Should you have any question or inquiry on this matter, please contact our sales staff.
Should you have any question or inquiry on this matter, please contact our sales staff.

HIGH CURRENT LEADED INDUCTORS



WAVE

FEATURES

- CAL45 is high current type, and has superior DC bias characteristics.
- Wide selection of configurations including axial leaded, formed radial leads to meet most manufacturing needs.
- LHLC08/LHLC10 series which are encapsulated in a resin housing, are radial leaded inductor for high current applications.

APPLICATIONS

- For DC/DC converter (LCD TV, PDP TV, CTV, DVD etc.)

OPERATING TEMP.

- -25°C~105°C (Including self-generated heat)

ORDERING CODE

[CA type]

C A L \triangle 4 5 T B 1 0 0 K \circ \circ \circ \circ \circ

1 Type	2 Product Specification	3 Dimensions (L×D) [mm] max	4 Lead Configurations	5 Nominal Inductance (μH)	6 Inductance Tolerance [%]	7 Internal code
CA High current axial leaded inductor	L△ Standard type △=Blank space	45 8.0×4.4	TB Axial lead (52mm lead space/ ammo pack) VB Formed lead/ ammo pack	example 1R5 1.5 120 12 ※R=decimal point	K ±10	△△△△△ Standard product △= Blank space

[LH type]

L H L C 0 8 T B 1 0 1 K \circ \circ \circ

1 Type	2 Product Specification	3 Dimensions [mm] max	4 Packing Code	5 Nominal Inductance (μH)	6 Inductance Tolerance [%]	7 Internal code
LH Radial leaded inductor	LC High current type	08 9.0 10 11.0	NB Bulk TB Ammo packing	example 1R5 1.5 120 12 102 1000 ※R=decimal point	J ±5 K ±10 M ±20	△△△ Standard product △= Blank space

EXTERNAL DIMENSIONS/STANDARD QUANTITY

[CA type]

Type	Fig.	Dimensions [mm] (inch)			Taped		Standard Quantity (pcs)	
		L	φD	φd	Straight	Formed	Bulk	Taped
CAL45		8.0max (0.315max)	4.4max (0.173max)	0.65±0.05 (0.026±0.002)	TB	VB	—	Axial lead 2000 Formed lead 1500

Unit : mm (inch)

[LH type]

Type	Fig.	D	H ₂	ℓ	F	φd	Standard Quantity (pcs)	
							Bulk	Taped
LHLC08		9.0max (0.354max)	9.5max (0.374max)	5.0±1.0 (0.197±0.039)	5.0±1.0 (0.197±0.039)	0.6±0.05 (0.024±0.002)	100	1000
LHLC10		11.0max (0.433max)	14.0max (0.551max)	5.0±1.0 (0.197±0.039)	5.0±1.0 (0.197±0.039)	0.6±0.05 (0.024±0.002)	50	500

Unit : mm (inch)

AVAILABLE INDUCTANCE RANGE

Range	Type	CAL45		LHLC08		LHLC10	
		R _{dc} max[Ω]	I _{max} [A]	R _{dc} max[Ω]	I _{max} [A]	R _{dc} max[Ω]	I _{max} [A]
0.1μ		0.036	3.3	0.013	5.4		
1.0μ		1.0μ		1.0μ		3.3μ	
10μ		0.14	1.7	0.041	2.9	0.034	3.6
100μ		1.2	0.59	0.32	1.0	0.18	1.5
1.0m		13.2	0.17	2.7	0.35	1.8	0.48
10m		10m		32.0	0.11	19.0	0.14
100m				33m		240.0	0.038
						150m	

* This catalog contains the typical specification only due to the limitation of space. When you consider purchase of our products, please check our specification. For details of each product (characteristics graph, reliability information, precautions for use, and so on), see our Web site (<http://www.ty-top.com/>) or CD catalogs.

PART NUMBERS

CAL45

Ordering code	EHS (Environmental Hazardous Substances)	Inductance [μ H]	Inductance Tolerance	Measuring frequency [MHz]	DC Resistance [Ω] (max.)	Rated current ※) [mA] (max.)	
						Saturation current Idc1	Temperature rise current Idc2
CAL 45 ○ 1R0K	RoHS	1.0	±10%	7.96	0.036	5600	3300
CAL 45 ○ 1R2K	RoHS	1.2			0.039	5000	3200
CAL 45 ○ 1R5K	RoHS	1.5			0.041	4400	3000
CAL 45 ○ 1R8K	RoHS	1.8			0.048	4100	2800
CAL 45 ○ 2R2K	RoHS	2.2			0.054	3900	2700
CAL 45 ○ 2R7K	RoHS	2.7			0.058	3500	2500
CAL 45 ○ 3R3K	RoHS	3.3			0.066	3100	2400
CAL 45 ○ 3R9K	RoHS	3.9			0.072	3000	2300
CAL 45 ○ 4R7K	RoHS	4.7			0.079	2800	2200
CAL 45 ○ 5R6K	RoHS	5.6			0.089	2500	2100
CAL 45 ○ 6R8K	RoHS	6.8		0.097	2200	2000	
CAL 45 ○ 8R2K	RoHS	8.2		0.110	2000	1900	
CAL 45 ○ 100K	RoHS	10		0.14	1700	1800	
CAL 45 ○ 120K	RoHS	12		0.17	1600	1450	
CAL 45 ○ 150K	RoHS	15		0.19	1400	1430	
CAL 45 ○ 180K	RoHS	18		0.24	1250	1300	
CAL 45 ○ 220K	RoHS	22		0.28	1200	1220	
CAL 45 ○ 270K	RoHS	27		0.33	1100	1130	
CAL 45 ○ 330K	RoHS	33		0.37	1000	1080	
CAL 45 ○ 390K	RoHS	39		0.47	920	900	
CAL 45 ○ 470K	RoHS	47		0.52	890	870	
CAL 45 ○ 560K	RoHS	56		0.75	790	710	
CAL 45 ○ 680K	RoHS	68		0.78	700	700	
CAL 45 ○ 820K	RoHS	82		0.92	620	640	
CAL 45 ○ 101K	RoHS	100		1.2	590	630	
CAL 45 ○ 121K	RoHS	120		1.6	550	490	
CAL 45 ○ 151K	RoHS	150		1.8	490	470	
CAL 45 ○ 181K	RoHS	180		2.3	420	450	
CAL 45 ○ 221K	RoHS	220		2.9	370	425	
CAL 45 ○ 271K	RoHS	270		3.4	350	355	
CAL 45 ○ 331K	RoHS	330		3.6	320	330	
CAL 45 ○ 391K	RoHS	390		4.9	290	280	
CAL 45 ○ 471K	RoHS	470		6.3	270	240	
CAL 45 ○ 561K	RoHS	560		7.0	250	240	
CAL 45 ○ 681K	RoHS	680		7.8	240	220	
CAL 45 ○ 821K	RoHS	820		11.0	220	210	
CAL 45 ○ 102K	RoHS	1000		13.2	190	170	
CAL 45 ○ 122K	RoHS	1200		17	170	150	
CAL 45 ○ 152K	RoHS	1500		22	150	140	
CAL 45 ○ 182K	RoHS	1800		27	140	120	
CAL 45 ○ 222K	RoHS	2200	36	130	110		
CAL 45 ○ 272K	RoHS	2700	45	110	90		
CAL 45 ○ 332K	RoHS	3300	65	100	75		
CAL 45 ○ 392K	RoHS	3900	69	95	70		
CAL 45 ○ 472K	RoHS	4700	80	90	65		
CAL 45 ○ 562K	RoHS	5600	90	90	60		
CAL 45 ○ 682K	RoHS	6800	100	80	60		
CAL 45 ○ 822K	RoHS	8200	125	75	50		
CAL 45 ○ 103K	RoHS	10000	155	65	45		
				0.0796			

○ Please specify the Lead configuration code.

※) The saturation current value (Idc1) is the DC current value having inductance decrease down to 10%. (at 20°C)

※) The temperature rise current value (Idc2) is the DC current value having temperature increase up to 40°C. (at 20°C)

※) The rated current is the DC current value that satisfies both of current value saturation current value and temperature rise current value.

LHLC08

Ordering code	EHS (Environmental Hazardous Substances)	Inductance [μ H]	Inductance Tolerance	Q (min.)	Self-resonant frequency [MHz] (min.)	DC Resistance [Ω] (max.)	Rated current [A] (max.)	Measuring frequency [MHz]
LH LC08 □ □ 1R0N	RoHS	1.0	±30%	40	76	0.013	5.4	7.96
LH LC08 □ □ 1R5M	RoHS	1.5			65	0.014	5.2	
LH LC08 □ □ 2R2M	RoHS	2.2			56	0.017	4.8	
LH LC08 □ □ 2R7M	RoHS	2.7			48	0.019	4.2	
LH LC08 □ □ 3R3M	RoHS	3.3			41	0.021	3.8	
LH LC08 □ □ 3R9M	RoHS	3.9			33	0.024	3.7	
LH LC08 □ □ 4R7M	RoHS	4.7			30	0.025	3.6	
LH LC08 □ □ 5R6M	RoHS	5.6			23	0.028	3.5	
LH LC08 □ □ 6R8M	RoHS	6.8			21	0.030	3.4	
LH LC08 □ □ 8R2M	RoHS	8.2			19	0.034	3.0	
LH LC08 □ □ 100K	RoHS	10	±10%	65	17	0.041	2.9	2.52
LH LC08 □ □ 120K	RoHS	12			16	0.044	2.8	
LH LC08 □ □ 150K	RoHS	15			13	0.053	2.6	
LH LC08 □ □ 180K	RoHS	18		50	12	0.060	2.4	
LH LC08 □ □ 220K	RoHS	22			11	0.068	2.3	

To next page

* This catalog contains the typical specification only due to the limitation of space. When you consider purchase of our products, please check our specification. For details of each product (characteristics graph, reliability information, precautions for use, and so on), see our Web site (<http://www.ty-top.com/>) or CD catalogs.

PART NUMBERS

Ordering code	EHS (Environmental Hazardous Substances)	Inductance [μ H]	Inductance Tolerance	Q (min.)	Self-resonant frequency (MHz) (min.)	DC Resistance [Ω] (max.)	Rated current [A] (max.)	Measuring frequency [MHz]	
LH LC08□□270K	RoHS	27	±10%	50	10	0.091	2.0	2.52	
LH LC08□□330K	RoHS	33			40	8.8	0.10		1.9
LH LC08□□390K	RoHS	39				8.4	0.12		1.7
LH LC08□□470K	RoHS	47				8.2	0.15		1.5
LH LC08□□560K	RoHS	56				7.9	0.17		1.4
LH LC08□□680K	RoHS	68		35		7.0	0.20		1.3
LH LC08□□820K	RoHS	82			6.5	0.22	1.2		
LH LC08□□101K	RoHS	100			25	5.7	0.32		1.0
LH LC08□□121K	RoHS	120				5.2	0.36		0.96
LH LC08□□151K	RoHS	150				4.7	0.41		0.88
LH LC08□□181K	RoHS	180		35		4.2	0.66	0.71	
LH LC08□□221K	RoHS	220				3.7	0.73	0.66	
LH LC08□□271K	RoHS	270			25	3.5	0.85	0.63	
LH LC08□□331K	RoHS	330				3.2	0.97	0.59	
LH LC08□□391K	RoHS	390				20	2.9	1.1	0.55
LH LC08□□471K	RoHS	470		2.4			1.3	0.49	
LH LC08□□561K	RoHS	560		25			2.2	1.5	0.47
LH LC08□□681K	RoHS	680			2.0		1.8	0.44	
LH LC08□□821K	RoHS	820			30		1.6	2.3	0.38
LH LC08□□102J	RoHS	1000			±5%	55	1.5	2.7	0.35
LH LC08□□122J	RoHS	1200	45				1.4	3.2	0.31
LH LC08□□152J	RoHS	1500	55	1.3			4.1	0.29	
LH LC08□□182J	RoHS	1800		1.2			4.8	0.26	
LH LC08□□222J	RoHS	2200		1.1			5.6	0.23	
LH LC08□□272J	RoHS	2700		1.0		7.5	0.21		
LH LC08□□332J	RoHS	3300		0.85		8.5	0.19		
LH LC08□□392J	RoHS	3900	65	0.78		9.7	0.18		
LH LC08□□472J	RoHS	4700		0.68		14	0.16		
LH LC08□□562J	RoHS	5600		60		0.62	16	0.15	
LH LC08□□682J	RoHS	6800				0.61	18	0.14	
LH LC08□□822J	RoHS	8200				0.60	20	0.13	
LH LC08□□103J	RoHS	10000	60			0.48	32	0.11	L:1kHz Q:0.0796
LH LC08□□123J	RoHS	12000				0.44	36	0.084	
LH LC08□□153J	RoHS	15000		0.35		62	0.068		
LH LC08□□183J	RoHS	18000		0.30		72	0.066		
LH LC08□□223J	RoHS	22000		0.28		82	0.057		
LH LC08□□273J	RoHS	27000	0.25	90		0.054			
LH LC08□□333J	RoHS	33000	0.23	100		0.053			

□ Please specify the packaging code. (TB: Taping, NB: Bulk)

LHLC10

Ordering code	EHS (Environmental Hazardous Substances)	Inductance [μ H]	Inductance Tolerance	Q (min.)	Self-resonant frequency (MHz) (min.)	DC Resistance [Ω] (max.)	Rated current [A] (max.)	Measuring frequency [MHz]		
LH LC10□□3R3M	RoHS	3.3	±20%	50	46	0.019	5.0	7.96		
LH LC10□□3R9M	RoHS	3.9			40	0.022	4.8			
LH LC10□□4R7M	RoHS	4.7			38	0.024	4.7			
LH LC10□□5R6M	RoHS	5.6			34	0.025	4.5			
LH LC10□□6R8M	RoHS	6.8			30	0.028	4.1			
LH LC10□□8R2M	RoHS	8.2			24	0.031	3.9			
LH LC10□□100K	RoHS	10			90	19	0.034		3.6	2.52
LH LC10□□120K	RoHS	12				16	0.038		3.4	
LH LC10□□150K	RoHS	15				12	0.042		3.2	
LH LC10□□180K	RoHS	18				9.2	0.046		3.0	
LH LC10□□220K	RoHS	22	60	8.6		0.061	2.8			
LH LC10□□270K	RoHS	27		7.1		0.069	2.7			
LH LC10□□330K	RoHS	33		6.8		0.078	2.6			
LH LC10□□390K	RoHS	39		6.7		0.085	2.4			
LH LC10□□470K	RoHS	47		50		6.2	0.093	2.3		
LH LC10□□560K	RoHS	56	5.2			0.10	2.1			
LH LC10□□680K	RoHS	68	40		4.6	0.12	2.0			
LH LC10□□820K	RoHS	82			4.7	0.13	1.8			
LH LC10□□101K	RoHS	100			3.8	0.18	1.5			
LH LC10□□121K	RoHS	120		30	3.2	0.25	1.3	0.796		
LH LC10□□151K	RoHS	150			2.9	0.29	1.2			
LH LC10□□181K	RoHS	180	2.6		0.40	1.0				
LH LC10□□221K	RoHS	220	2.3		0.44	0.95				
LH LC10□□271K	RoHS	270	30		2.1	0.50	0.90		0.796	
LH LC10□□331K	RoHS	330		2.0	0.56	0.86				
LH LC10□□391K	RoHS	390		1.8	0.62	0.75				
LH LC10□□471K	RoHS	470		1.7	0.84	0.65				
LH LC10□□561K	RoHS	560		1.5	0.93	0.61				
LH LC10□□681K	RoHS	680	±10%	30	1.4	1.0	0.57			
LH LC10□□821K	RoHS	820			1.3	1.4	0.50			

To next page

* This catalog contains the typical specification only due to the limitation of space. When you consider purchase of our products, please check our specification. For details of each product (characteristics graph, reliability information, precautions for use, and so on), see our Web site (<http://www.ty-top.com/>) or CD catalogs.

PART NUMBERS

Ordering code	EHS (Environmental Hazardous Substances)	Inductance [μ H]	Inductance Tolerance	Q (min.)	Self-resonant frequency [MHz] (min.)	DC Resistance [Ω] (max.)	Rated current [A] (max.)	Measuring frequency [MHz]	
LH LC10□□102J	RoHS	1000	±5%	50	1.2	1.8	0.48	0.252	
LH LC10□□122J	RoHS	1200			0.87	2.3	0.40		
LH LC10□□152J	RoHS	1500			0.83	2.7	0.37		
LH LC10□□182J	RoHS	1800			0.75	3.0	0.36		
LH LC10□□222J	RoHS	2200			0.70	3.9	0.32		
LH LC10□□272J	RoHS	2700			0.67	4.3	0.30		
LH LC10□□332J	RoHS	3300			0.56	5.8	0.26		
LH LC10□□392J	RoHS	3900			0.54	6.4	0.25		
LH LC10□□472J	RoHS	4700			0.49	7.1	0.24		
LH LC10□□562J	RoHS	5600			0.41	9.0	0.21		
LH LC10□□682J	RoHS	6800			0.38	10	0.20		
LH LC10□□822J	RoHS	8200			0.36	12	0.18		
LH LC10□□103J	RoHS	10000			0.29	19	0.14		L:1kHz Q:0.0796
LH LC10□□123J	RoHS	12000			0.27	21	0.13		
LH LC10□□153J	RoHS	15000			0.24	34	0.11		
LH LC10□□183J	RoHS	18000			0.21	38	0.10		
LH LC10□□223J	RoHS	22000			0.20	43	0.095		
LH LC10□□273J	RoHS	27000			0.15	67	0.076		
LH LC10□□333J	RoHS	33000		0.14	76	0.068			
LH LC10□□393J	RoHS	39000		0.13	84	0.065			
LH LC10□□473J	RoHS	47000		0.12	96	0.061			
LH LC10□□563J	RoHS	56000		0.10	170	0.045	L:1kHz Q:0.0252		
LH LC10□□683J	RoHS	68000		0.095	200	0.043			
LH LC10□□823J	RoHS	82000		0.088	210	0.041			
LH LC10□□104J	RoHS	100000		0.085	240	0.038			
LH LC10□□124J	RoHS	120000		0.070	260	0.037			
LH LC10□□154J	RoHS	150000		0.069	300	0.035			

□ Please specify the packaging code. (TB: Taping, NB: Bulk)

FERRITE PRODUCTS

ELECTRICAL CHARACTERISTICS

DC Bias characteristics

(Measured by HP4285A)

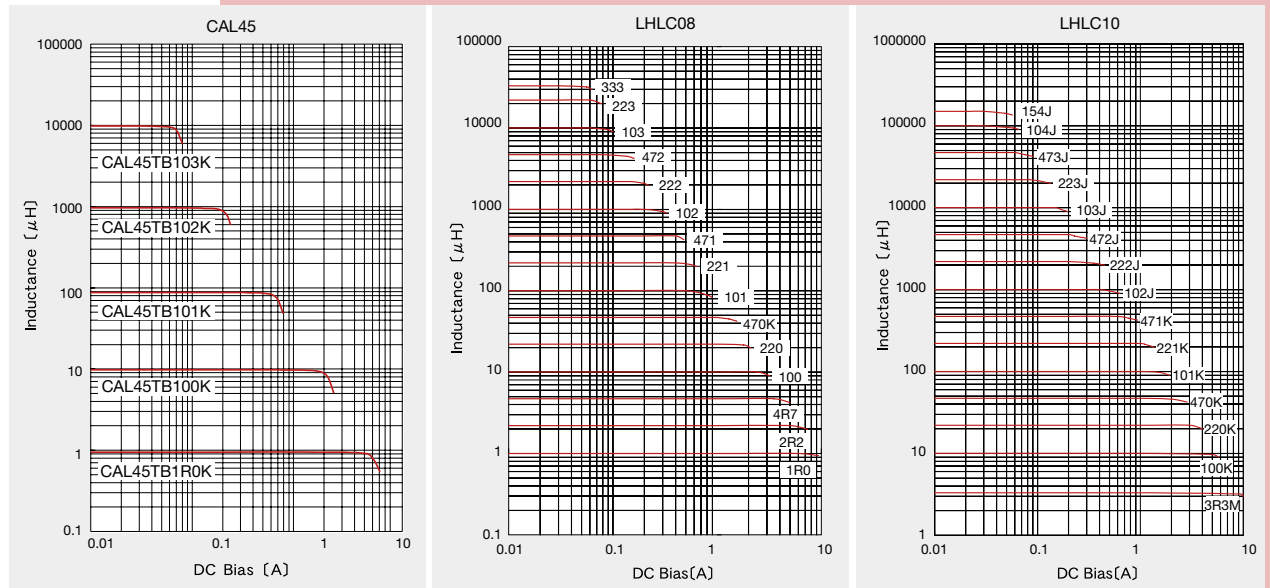

* This catalog contains the typical specification only due to the limitation of space. When you consider purchase of our products, please check our specification. For details of each product (characteristics graph, reliability information, precautions for use, and so on), see our Web site (<http://www.ty-top.com/>) or CD catalogs.

PACKAGING

① Minimum Quantity

Type (EIA)	Standard quantity (pcs)	
	Bulk	Taped
CAL45	—	Axial lead 2000 Formed lead 1500
LHLC08	100	1000
LHLC10	50	500

② Taping dimensions

- CAL 45 TB (a : 52mm lead space)
(2.05 inches)

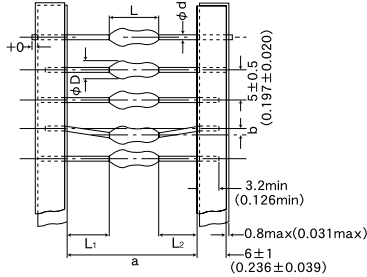

Type	Dimensions						Minimum insertion pitch
	φD	L	a	b	L ₁ -L ₂	φd	
CAL45	4.4max (0.173max)	8.0max (0.315max)	52 ⁺² ₋₁ (2.05 ^{+0.079} _{-0.039})	1.2max (0.047max)	1.0max (0.039max)	0.65±0.05 (0.026±0.002)	10.0 (0.394)

Unit : mm (inch)

③ Bulk dimensions

Type	Dimensions					
	φD (max)	H ₂ (max)	F*	ℓ	φd	
LHLC08	9.0 (0.354)	9.5 (0.374)	5.0±1.0 (0.197±0.039)	5.0±1.0 (0.197±0.039)	0.6±0.05 (0.024±0.002)	
LHLC10	11.0 (0.433)	14.0 (0.551)	5.0±1.0 (0.197±0.039)	5.0±1.0 (0.197±0.039)	0.6±0.05 (0.024±0.002)	

*Measured at the base of the leads. Unit : mm (inch)

- CAL 45VB

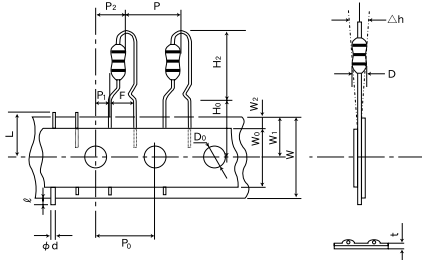

Type	Symbol	Dimensions	Symbol	Dimensions
CAL 45	D	φ4.4max	W	18.0 ^{+1.0} _{-0.5} (0.709 ^{+0.039} _{-0.020})
	H ₂	14.0max (0.551max)	W ₀	12.5min (0.492min)
	H ₀	16.0±1.0 (0.630±0.039)	W ₁	9.0 ^{+0.75} _{-0.5} (0.354 ^{+0.030} _{-0.020})
	P	12.7±1.0 (0.500±0.039)	W ₂	3.0max ^{※2} (0.118max)
	P ₀	12.7±0.3 ^{※1} (0.500±0.012)	ℓ	2.0max (0.079max)
	P ₁	3.85±0.7 (0.152±0.028)	D ₀	φ4.0±0.2 (φ0.157±0.008)
	P ₂	6.35±1.3 (0.250±0.051)	φd	φ0.65±0.05 (φ0.026±0.002)
	F	5.0±1.0 (0.197±0.039)	L	11.0max (0.433max)
	Δh	0.0±2.0 (0.0±0.079)	t	0.9max (0.035max)

Unit : mm (inch)

- ※1 Accumulated error for 20 pitches is ± 1mm.
- ※2 Bonding tape must not protrude from the base tape.

- LHLC08, LHLC10

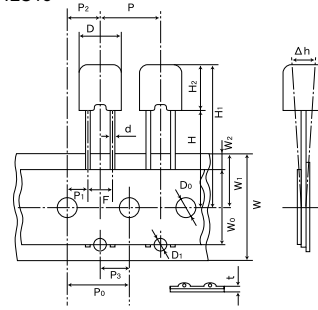

	LHLC08	LHLC10
D	φ9.0max (φ0.354max)	φ11.0max (φ0.433max)
H ₁	30.5max (1.20max)	34.0max (1.34max)
H	18.0 ^{+2.0} _{-0.0} (0.709 ^{+0.079} _{-0.000})	18.0 ^{+2.0} _{-0.0} (0.709 ^{+0.079} _{-0.000})
H ₂	9.5max (0.374max)	14.0max (0.551max)
P	12.7±1.0 (0.500±0.039)	12.7±1.0 (0.500±0.039)
P ₀	12.7±0.3 ^{※1} (0.500±0.012)	12.7±0.3 ^{※1} (0.500±0.012)
P ₁	3.85±0.7 (0.152±0.028)	3.85±0.7 (0.152±0.028)
P ₂	6.35±1.3 (0.250±0.051)	6.35±1.3 (0.250±0.051)
F	5.0 ^{+0.8} _{-0.2} (0.197 ^{+0.031} _{-0.008})	5.0 ^{+0.8} _{-0.2} (0.197 ^{+0.031} _{-0.008})
h	0.0±2.0 (0.0±0.079)	0.0±2.0 (0.0±0.079)
W	18.0 ^{+1.0} _{-0.5} (0.709 ^{+0.039} _{-0.020})	18.0 ^{+1.0} _{-0.5} (0.709 ^{+0.039} _{-0.020})
W ₀	12.5min (0.492min)	12.5min (0.492min)
W ₁	9.0±0.5 (0.354±0.020)	9.0±0.5 (0.354±0.020)
W ₂	3.0max ^{※2} (0.118max)	3.0max ^{※2} (0.118max)
D ₀	φ4.0±0.2 (φ0.158±0.008)	φ4.0±0.2 (φ0.158±0.008)
φd	φ0.6±0.05 (φ0.024±0.002)	φ0.6±0.05 (φ0.024±0.002)
t	0.6±0.3 (0.024±0.012)	0.6±0.3 (0.024±0.012)
D ₁	φ1.8 (0.071)	φ1.8 (0.071)
P ₃	6.35 (0.25)	6.35 (0.25)

- ※1 Accumulated error for 20 pitches is 1mm.
- ※2 Bonding tape must not protrude from the base tape.

Unit : mm (inch)

* This catalog contains the typical specification only due to the limitation of space. When you consider purchase of our products, please check our specification. For details of each product (characteristics graph, reliability information, precautions for use, and so on), see our Web site (<http://www.ty-top.com/>) or CD catalogs.

RELIABILITY DATA

1. Operating temperature Range

LA Type	
CAL45 Type	-25~+105°C
LHL□□□	
FBA/FBR	-25~+85°C
FL05□ Type	
FL06BT Type	-25~+105°C

[Test Method and Remarks]

LA·CA·FL : Including self-generated heat
LHL□□□ : Including self-generated heat

2. Storage temperature Range

LA Type	
CAL45 Type	
LHL□□□	
FBA/FBR	-40~+85°C
FL05□ Type	
FL06BT Type	

3. Rated current

LA Type	
CAL45 Type	
LHL□□□	
FBA/FBR	Within the specified tolerance
FL05□ Type	
FL06BT Type	

[Test Method and Remarks]

LA, CA : The maximum DC value having inductance within 10% and temperature increase within 40°C (LA:20°C) by the application of DC bias.
LHL□□□ : The maximum DC value having inductance decrease within 10% (LHLC08, LHLC10 : within 30%) and temperature increase within the following specified temperature by the application of DC bias.

Reference temperature : 25°C (LHL08, LHL10, LHL13)
: 30°C (LHL16, LHLP□□)
: 40°C (LHLC08, LHLC10)

FB : No disconnection or appearance abnormality by continuous current application for 30 min. Change after the application shall be within ±20% of the initial value.

This is not guaranteed for electrical characteristics during current application.

FL : The maximum DC value having temperature rise within specified value.

4. Impedance

LA Type	
CAL45 Type	
LHL□□□	
FBA/FBR	Within the specified tolerance
FL05□ Type	
FL06BT Type	Refer to individual specification

[Test Method and Remarks]

FB : Measuring equipment : Impedance analyzer (HP4191A) or its equivalent

Measuring frequency : Specified frequency

FL06BT : Measuring equipment : 4291A (HP) or its equivalent

Measuring frequency : Specified frequency

5. Inductance

LA Type	
CAL45 Type	Within the specified tolerance
LHL□□□	
FBA/FBR	
FL05□ Type	Within the specified tolerance
FL06BT Type	

[Test Method and Remarks]

LA, CA : Measuring equipment : LCR meter (HP4285A + HP42851A or its equivalent)
Measuring frequency : Specified frequency

LHL□□□ : Measuring equipment : LCR meter (HP4285A+HP42851A or its equivalent)
LCR meter (HP4263A) or its equivalent (at 1KHz)

Measuring frequency : Specified frequency

FL05R□ : Measuring equipment : HP4262A or its equivalent

Measuring frequency : 1kHz

6. Q

LA Type	Within the specified tolerance
CAL45 Type	
LHL□□□	
FBA/FBR	
FL05□ Type	
FL06BT Type	

[Test Method and Remarks]

LA : Measuring equipment : LCR meter (HP4285A + HP42851A or its equivalent)

Measuring frequency : Specified frequency

LHL□□□ (except LHLP) : Measuring equipment : LCR meter (HP4285A+HP42851A or its equivalent)
LCR meter (HP4263A) or its equivalent (at 1kHz)

Measuring frequency : Specified frequency

* This catalog contains the typical specification only due to the limitation of space. When you consider purchase of our products, please check our specification.
For details of each product (characteristics graph, reliability information, precautions for use, and so on), see our Web site (<http://www.ty-top.com/>) or CD catalogs.

RELIABILITY DATA

7. DC Resitance

LA Type	Within the specified tolerance
CAL45 Type	
LHL□□□	
FBA/FBR	
FL05□ Type	
FL06BT Type	

[Test Method and Remarks]

LA, CA : Measuring equipment : low ohmmeter (A&D AD5812 or its equivalent)
 LHL□□□·FB·FL : Measuring equipment : DC ohmmeter

8. Self resonance frequency

LA Type	Within the specified tolerance
CAL45 Type	
LHL□□□	
FBA/FBR	
FL05□ Type	
FL06BT Type	

[Test Method and Remarks]

LA : Measuring equipment : Network analyzer (Anritsu MS620J or its equivalent)
 LHL□□□ (except LHLP) : Measuring equipment : (HP4191A, 4192A) its equivalent

9. Temperature characteristic

LA Type	△L/L : Within ±5%
CAL45 Type	
LHL□□□	△L/L : Within ±7% (except LHLP16 : Within ±20%)
FBA/FBR	
FL05□ Type	
FL06BT Type	

[Test Method and Remarks]

LA : Change of maximum inductance deviation in step 1 to 5

Step	Temperature (°C)
1	20
2	-25 (Minimum operating temperature)
3	20 (Standard temperature)
4	+85 (Maximum operating temperature)
5	20

LHL□□□ : Change of maximum inductance deviation in step 1 to 5

Temperature at step 1 : 20°C
 Temperature at step 2 : Minimum operating temperature
 Temperature at step 3 : 20°C (Standard temperature)
 Temperature at step 4 : Maximum operating temperature
 Temperature at step 5 : 20°C

10. Terminal strength : tensile force

LA Type	No abnormality such as cut lead, or looseness.
CAL45 Type	
LHL□□□	
FBA/FBR	
FL05□ Type	
FL06BT Type	

[Test Method and Remarks]

LA : Apply the stated tensile force progressively in the direction to draw terminal.

force (N)	duration (s)
25	5

CA : Apply the stated tensile force progressively in the direction to draw terminal.

force (N)	duration (s)
10	10

LHL□□□ : Apply the stated tensile force progressively in the direction to draw terminal.

Nominal wire diameter tensile ϕd (mm)	force (N)	duration (s)
$0.3 < \phi d \leq 0.5$	5	30±5
$0.5 < \phi d \leq 0.8$	10	
$0.8 < \phi d \leq 1.2$	25	

FBA/FBR : A bead shall be fixed and static loaded $20 \pm 1N$ (2.0 ± 0.1 kgf) in axial direction of lead wire in 10 ± 1 seconds.

FL05R□ : Fix the component in the direction to draw terminal, and gradually apply the tensile force of 4.9N.

11. Over current

LA Type	No emission of smoke no firing.
CAL45 Type	
LHL□□□	There shall be no scorch or short of wire. LHLC08, LHLC10 : There shall be no firing.
FBA/FBR	
FL05□ Type	
FL06BT Type	

[Test Method and Remarks]

LHL□□□/LA·CAL45 Type : Measuring current : Rated current×2
 Duration : 5 min.
 Number of measuring : one time

* This catalog contains the typical specification only due to the limitation of space. When you consider purchase of our products, please check our specification.
 For details of each product (characteristics graph, reliability information, precautions for use, and so on), see our Web site (<http://www.ty-top.com/>) or CD catalogs.

RELIABILITY DATA

12. Terminal strength : bending

LA Type	No abnormality such as cut lead, or looseness.
CAL45 Type	
LHL□□□	
FBA/FBR	
FL05□ Type	
FL06BT Type	

[Test Method and Remarks]

LA, CA : Suspend a mass at the end the terminal, incline the body though angel of 90 and return it to initial position. This operation is done over a period of 2-3 sec. Then second bend in the opposite direction shall be made.
Number of bends : Two times.

Nominal wire diameter tensile ϕd (mm)	Bending force (N)	Mass reference weight (kg)
$0.5 < \phi d \leq 0.8$	5	0.50

LH·FB : Suspend a mass at the end the terminal, incline the body though angel of 90 and return it to initial position. This operation is done over a period of 2-3 sec. Then second bend in the opposite direction shall be made.
Number of bends : Two times.

Nominal wire diameter tensile ϕd (mm)	Bending force (N)	Mass reference weight (kg)
$0.3 < \phi d \leq 0.5$	2.5	0.25
$0.5 < \phi d \leq 0.8$	5	0.5
$0.8 < \phi d \leq 1.2$	10	1.0

13. Insulation resistance : between the terminals and body

LA Type	100M Ω min.
CAL45 Type	
LHL□□□	
FBA/FBR	
FL05□ Type	
FL06BT Type	

[Test Method and Remarks]

LHL□□□ : Applied voltage : 500 VDC
Duration : 60 sec.

14. Insulation resistance : between terminals and core

LA Type	1M Ω min. (Other than materail code MA)
CAL45 Type	
LHL□□□	
FBA/FBR	
FL05□ Type	
FL06BT Type	

[Test Method and Remarks]

FBA·FBR : Applied voltage : 100 VDC
Duration : 60±5 sec.

15. Withstanding : between the terminals and body

LA Type	No abnormality such as insulation damage
CAL45 Type	
LHL□□□	
FBA/FBR	
FL05□ Type	
FL06BT Type	

[Test Method and Remarks]

LHL□□□ : Accoding to JIS C5102. 7. 1. 3 (C)
Metal global method
Applied voltage : 500 VDC
Duration : 60 sec.

16. DC bias characteristic

LA Type	$\Delta L/L$: Within -10%
CAL45 Type	
LHL□□□	
FBA/FBR	
FL05□ Type	
FL06BT Type	

[Test Method and Remarks]

LA, CA : Measure inductance with appliation of rated current using LCR meter to compare it with the initial value.

17. Body strength

LA Type	No abnormality as damage.
CAL45 Type	
LHL□□□	
FBA/FBR	No abnormality such as cracks on body.
FL05□ Type	
FL06BT Type	

[Test Method and Remarks]

LA : Applied force : 30N
Duration : 10 sec.
Speed : Shall attain to specified force in 2 sec.

CAL45 : Applied force : 50N
Duration : 10 sec.
Speed : Shall attain to specified force in 2 sec.

FBA : Applied force : 50±3N
Duration : 30±1 sec.

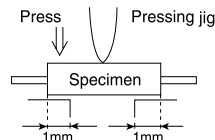

* This catalog contains the typical specification only due to the limitation of space. When you consider purchase of our products, please check our specification.
For details of each product (characteristics graph, reliability information, precautions for use, and so on), see our Web site (<http://www.ty-top.com/>) or CD catalogs.

RELIABILITY DATA

18. Resistance to vibration	
LA Type	Δ L/L : Within $\pm 5\%$ Q : 30min
CAL45 Type	Δ L/L : Within $\pm 5\%$
LHL□□□	Appearance : No abnormality Δ L/L : Within $\pm 5\%$ Q change : Within $\pm 30\%$ (LHLP : only Δ L/L)
FBA/FBR	Appearance : No abnormality Impedance change : Within $\pm 20\%$
FL05□ Type	
FL06BT Type	

[Test Method and Remarks]

LA, CA : Directions : 2 hrs each in X, Y and Z directions total : 6hrs.
 Frequency range : 10 to 55 to 10Hz (1min.)
 Amplitude : 1.5mm
 Mounting method : Soldering onto printed board.
 Recovery : At least 1hr of recovery under the standard condition after the test, followed by the measurement within 2hrs.

LHL□□□·FB : Directions : 2 hrs each in X, Y and Z directions total : 6hrs.
 Frequency range : 10 to 55 to 10Hz (1min.)
 Amplitude : 1.5mm (But don't exceed acceleration 196m/s^2 (two power))
 Mounting method : Soldering onto printed board.

19. Resistance to shock	
LA Type	No significant abnormality in appearance
CAL45 Type	
LHL□□□	
FBA/FBR	
FL05□ Type	
FL06BT Type	

[Test Method and Remarks]

LA, CA : Drop test
 Impact material : concrete or vinyl tile
 Height : 1m
 Total number of drops : 10 times

20. Solderability	
LA Type	At least 75% of terminal electrode is covered by new solder.
CAL45 Type	
LHL□□□	At least 75% of terminal electrode is covered by new solder.
FBA/FBR	At least 90% of terminal electrode is covered by new solder.
FL05□ Type	
FL06BT Type	At least 75% of terminal electrode is covered by new solder.

[Test Method and Remarks]

LA, CA : Solder temperature : $230\pm 5^\circ\text{C}$
 Duration : 2 ± 0.5 sec.

LHL□□□ : Solder temperature : $235\pm 5^\circ\text{C}$
 Duration : 2 ± 0.5 sec.
 Immersion depth : Up to 1.5mm from bottom of case.

FB : Solder temperature : $230\pm 5^\circ\text{C}$
 Duration : 3 ± 1 sec.
 Immersion depth : Up to 1.5mm from terminal root.

FL05R□ : Solder temperature : $230\pm 5^\circ\text{C}$
 Duration : 2 ± 0.5 sec.
 Immersion depth : Up to 2 to 2.5mm from terminal root.

FL06BT : Solder temperature : $230\pm 5^\circ\text{C}$
 Duration : 3 ± 1 sec.
 Immersion depth : Up to 0.5 to 1.0mm from terminal root.

21. Resistance to soldering heat	
LA Type	No significant abnormality in appearance
CAL45 Type	Δ L/L : Within $\pm 5\%$
LHL□□□	No significant abnormality in appearance Inductance change : Within $\pm 5\%$ Q change : Within $\pm 30\%$ (LHLP : only Δ L/L)
FBA/FBR	No significant abnormality in appearance Impedance change : Within $\pm 20\%$
FL05□ Type	Refer to individual specification
FL06BT Type	No significant abnormality in appearance Impedance change : Within $\pm 20\%$

[Test Method and Remarks]

LA, CA : Solder temperature : (CA) $270\pm 5^\circ\text{C}$, (LA) $260\pm 5^\circ\text{C}$
 Duration : 5 ± 0.5 sec. One time
 Immersed conditions : Inserted into substrate with $t=1.6\text{mm}$
 Recovery : At least 1hr of recovery under the standard condition after the test, followed by the measurement within 2hrs.

LHL□□□ : Solder bath method : Solder temperature : $260\pm 5^\circ\text{C}$
 Duration : 10 ± 1 sec.
 Up to 1.5mm from bottom of case.

Manual soldering : Solder temperature : $350\pm 10^\circ\text{C}$ (At the tip of soldering iron)
 Duration : 5 ± 1 sec.
 Up to 1.5mm from bottom of case.

Caution : No excessive pressing shall be applied to terminald.
 Recovery : 4 to 24hrs of recovery under the standard condition after the test.

FB : Solder bath method : Condition 1 : Solder temperature : $260\pm 5^\circ\text{C}$
 Duration : 10 ± 1 sec.
 Immersion depth : Up to 1.5mm from terminal root.
 Condition 2 : Solder temperature : $350\pm 5^\circ\text{C}$
 Duration : 3 ± 1 sec.
 Immersion depth : Up to 1.5mm from terminal root.

Recovery : 3hrs of recovery under the standard condition after the test.

FL : Solder condition : $260\pm 5^\circ\text{C}$ 10 ± 1 sec.
 Immersion depth : Up to 0.5 to 1.0mm from terminal root.
 Recovery : 3hrs of recovery under the standard condition after the test.

* This catalog contains the typical specification only due to the limitation of space. When you consider purchase of our products, please check our specification.
 For details of each product (characteristics graph, reliability information, precautions for use, and so on), see our Web site (<http://www.ty-top.com/>) or CD catalogs.

RELIABILITY DATA

22. Resisistance to solvent

LA Type	Please avoid the ultrasonic cleaning of this product.	
CAL45 Type		
LHL□□□		
FBA/FBR		No significant abnormality in appearance Impedance change : Within ±20%
FL05□ Type		
FL06BT Type		

[Test Method and Remarks]

FB : Solvent temperature : 20~25°C
 Duration : 30±5 sec.
 Solvent type : Acetone, trichloroethylene
 Recovery : 3hrs of recovery under the standard condition after the test.

23. Thermal shock

LA Type	△L/L : Within ±10% Q : 30min		
CAL45 Type	△L/L : Within ±10%		
LHL□□□	Appearance : No abnormality	Inductance change : Within ±10%	Q change : Within ±30% (LHLP : only △L/L)
FBA/FBR	Appearance : No abnormality	Impedance change : Within ±20%	
FL05□ Type	Refer to individual specification		
FL06BT Type	Appearance : No abnormality	Impedance change : Within ±20%	

[Test Method and Remarks]

LA, CA : Conditions for 1cycle

Step	Temperature (°C)	Duration (min.)
1	-25 ⁺⁰ ₋₃	30±3
2	Room temperature	Within 3
3	+85 ⁺² ₋₀	30±3
4	Room temperature	Within 3

Number of cycles : 5 cycles
 Recovery : At least 1hr of recovery under the standard condition after the removal from test chamber, followed by the measurement within 2hrs.

LHL□□□·FB : According to JIS C0025

Conditions for 1 cycle

Step	Temperature (°C)	Duration (min.)
1	Minimum operating temperature ⁺⁰ ₋₃	30±3
2	Room temperature	Within 3
3	Minimum operating temperature ⁺² ₋₀	30±3
4	Room temperature	Within 3

Number of cycles : 10 cycles (LHL□□□)
 : 5 cycles (FBA, FBR)
 Recovery : 4 to 24hrs of recovery under the standard condition after the removal from the test chamber. (LHL□□□)
 : 3hrs of recovery under the standard condition after the removal from the test chamber. (FBA, FBR)

FL : According to JIS C0025

Conditions for 1 cycle

Step	Temperature (°C)	Duration (min.)
1	-25 ⁺⁰ ₋₃	30±3
2	Room temperature	Within 3
3	+85 ⁺² ₋₀	30±3
4	Room temperature	Within 3

Number of cycles : 10 cycles
 Recovery : 1 to 2hrs of recovery under the standard condition after the removal from the test chamber.

24. Damp heat

LA Type	△L/L : Within ±10% Q : 30min
CAL45 Type	△L/L : Within ±10%
LHL□□□	
FBA/FBR	Appearance : No abnormality Impedance change : Within ±20%
FL05□ Type	
FL06BT Type	

[Test Method and Remarks]

LA, CA : Temperature : 40±2°C
 Humidity : 90~95%RH
 Duration : 1000 hrs
 Recovery : At least 1hr of recovery under the standard removal from test chamber, followed by the measurement within 2hrs.

FB : Temperature : 60±2°C

Humidity : 90~95%RH
 Duration : 1000 hrs
 Recovery : 1 to 2hrs of recovery under the standard condition after the removal from the test chamber.

* This catalog contains the typical specification only due to the limitation of space. When you consider purchase of our products, please check our specification.
 For details of each product (characteristics graph, reliability information, precautions for use, and so on), see our Web site (<http://www.ty-top.com/>) or CD catalogs.

RELIABILITY DATA

25. Loading under damp heat	
LA Type	$\Delta L/L$: Within $\pm 10\%$ Q : $\pm 30\text{min}$
CAL45 Type	$\Delta L/L$: Within $\pm 10\%$
LHL□□□	Appearance : No abnormality Inductance change : Within $\pm 10\%$ Q change : Within $\pm 30\%$ (LHLP : only $\Delta L/L$)
FBA/FBR	
FL05□ Type	Refer to individual specification
FL06BT Type	Appearance : No abnormality Impedance change : Within $\pm 20\%$
[Test Method and Remarks]	
LA, CA	Temperature : $40 \pm 2^\circ\text{C}$ Humidity : $90 \sim 95\%RH$ Duration : 1000 hrs Applied current : Rated current Recovery : At least 1hr of recovery under the standard removal from test chamber, followed by the measurement within 2hrs.
LHL□□□	Temperature : $40 \pm 2^\circ\text{C}$ Humidity : $90 \sim 95\%RH$ Duration : 1000 ± 24 hrs Applied current : Rated current Recovery : 1 to 2hrs of recovery under the standard condition after the removal from the test chamber.
FL	Temperature : $60 \pm 3^\circ\text{C}$ Humidity : $90 \sim 95\%RH$ Duration : 500 (+12, -0) hrs Applied current : Rated current Recovery : 1 to 2hrs of recovery under the standard condition after the removal from the test chamber.
26. Loading at high temperature	
LA Type	$\Delta L/L$: Within $\pm 10\%$ Q : $\pm 30\text{min}$
CAL45 Type	$\Delta L/L$: Within $\pm 10\%$
LHL□□□	
FBA/FBR	
FL05□ Type	
FL06BT Type	
[Test Method and Remarks]	
LA, CA	Temperature : $85 \pm 2^\circ\text{C}$ Duration : 1000 hrs Applied current : Rated current Recovery : At least 1hr of recovery under the standard removal from test chamber, followed by the measurement within 2hrs.
27. Low temperature life test	
LA Type	$\Delta L/L$: Within $\pm 10\%$ Q : $\pm 30\text{min}$
CAL45 Type	$\Delta L/L$: Within $\pm 10\%$
LHL□□□	Appearance : No abnormality Inductance change : Within $\pm 10\%$ Q change : Within $\pm 30\%$ (LHLP : only $\Delta L/L$)
FBA/FBR	
FL05□ Type	Refer to individual specification
FL06BT Type	Appearance : No abnormality Impedance change : Within $\pm 20\%$
[Test Method and Remarks]	
LA, CA	Temperature : $-25 \pm 2^\circ\text{C}$ Duration : 1000 hrs Recovery : At least 1hr of recovery under the standard removal from test chamber, followed by the measurement within 2hrs.
LHL□□□	Temperature : $-40 \pm 3^\circ\text{C}$ Duration : 1000 ± 24 hrs Recovery : 1 to 2hrs of recovery under the standard condition after the removal from the test chamber.
FL	Temperature : $-40 \pm 3^\circ\text{C}$ Duration : 500 (+12, -0) hrs Recovery : 1 to 2hrs of recovery under the standard condition after the removal from the test chamber.
28. High temperature life test	
LA Type	
CAL45 Type	
LHL□□□	Appearance : No abnormality Inductance change : Within $\pm 10\%$ Q change : Within $\pm 30\%$ (LHLP : only $\Delta L/L$)
FBA/FBR	
FL05□ Type	Refer to individual specification
FL06BT Type	Appearance : No abnormality Impedance change : Within $\pm 20\%$
[Test Method and Remarks]	
LHL□□□	Temperature : $105 \pm 3^\circ\text{C}$ Duration : 1000 ± 24 hrs Recovery : 1 to 2hrs of recovery under the standard condition after the removal from the test chamber.
FL	Temperature : $85 \pm 3^\circ\text{C}$ Duration : 500 (+12, -0) hrs Recovery : 1 to 2hrs of recovery under the standard condition after the removal from the test chamber.

* This catalog contains the typical specification only due to the limitation of space. When you consider purchase of our products, please check our specification.
For details of each product (characteristics graph, reliability information, precautions for use, and so on), see our Web site (<http://www.ty-top.com/>) or CD catalogs.

PRECAUTIONS

CAL Type, LH Type, FB Type, FL Type, LA Type

1. Circuit Design	
Precautions	<ul style="list-style-type: none"> ◆ Operating environment 1. The products described in this specification are intended for use in general electronic equipment (office supply equipment, telecommunications systems, measuring equipment, and household equipment). They are not intended for use in mission-critical equipment or systems requiring special quality and high reliability (traffic systems, safety equipment, aerospace systems, nuclear control systems and medical equipment including life-support systems,) where product failure might result in loss of life, injury or damage. For such uses, contact TAIYO YUDEN Sales Department in advance.
2. PCB Design	
Precautions	<ul style="list-style-type: none"> ◆ Design 1. Please design insertion pitches of a base in the pitches that fitted a terminal interval.
Technical considerations	<ul style="list-style-type: none"> ◆ Design 1. When Inductors are mounted onto a PC board, hole dimensions on the board should match the lead pitch of the component, if not, it will cause breakage of the terminals or cracking of terminal roots covered with resin as excess stress travels through the terminal legs.
3. Considerations for automatic placement	
Precautions	<ul style="list-style-type: none"> ◆ Adjustment of mounting machine 1. Excessive impact load should not be imposed on the products when mounting onto the PC boards. 2. Mounting and soldering conditions should be checked beforehand.
Technical considerations	<ul style="list-style-type: none"> ◆ Adjustment of mounting machine 1. When installing products, care should be taken not to apply distortion stress as it may deform the products.
4. Soldering	
Precautions	<ul style="list-style-type: none"> ◆ Wave soldering 1. Please refer to the specifications in the catalog for a wave soldering. 2. Do not immerse the entire Inductors in the flux during the soldering operation. ◆ Lead free soldering 1. When using products with lead free soldering, we request to use them after confirming of adhesion, temperature of resistance to soldering heat, soldering etc sufficiently. Recommended conditions for using a soldering iron: <ul style="list-style-type: none"> • Put the soldering iron on the land-pattern. • Soldering iron's temperature - Below 350°C • Duration - 3 seconds or less • The soldering iron should not directly touch the inductor. ◆ Reflow soldering 1. As for reflow soldering, please contact our sales staff.
Technical considerations	<ul style="list-style-type: none"> ◆ Lead free soldering 1. If products are used beyond the range of the recommended conditions, heat stresses may deform the products, and consequently degrade the reliability of the products.
5. Cleaning	
Precautions	<ul style="list-style-type: none"> ◆ Cleaning conditions 1. CAL type, LH type, LA Type Please do not do cleaning by a supersonic wave.
Technical considerations	<ul style="list-style-type: none"> ◆ Cleaning conditions 1. CAL type, LH type, LA Type If washing by supersonic waves, supersonic waves may deform products.
6. Handling	
Precautions	<ul style="list-style-type: none"> ◆ Handling 1. Keep the inductors away from all magnets and magnetic objects. ◆ Mechanical considerations 1. Please do not give the inductors any excessive mechanical shocks. 2. LH type If inductors are dropped onto the floor or a hard surface they should not be used. ◆ Packing 1. Please do not give the inductors any excessive mechanical shocks. In loading, please pay attention to handling indication mentioned in a packing box (a loading direction / number of maximum loading / fragile item).
Technical considerations	<ul style="list-style-type: none"> ◆ Handling 1. There is a case that a characteristic varies with magnetic influence. ◆ Mechanical considerations 1. There is a case to be damaged by a mechanical shock. 2. LH type There is a case to be broken by a fall. ◆ Packing 1. There is a case that a lead route turns by a fall or an excessive shock.
7. Storage conditions	
Precautions	<ul style="list-style-type: none"> ◆ Storage 1. To maintain the solderability of terminal electrodes and to keep the packing material in good condition, temperature and humidity in the storage area should be controlled. Recommended conditions <ul style="list-style-type: none"> • Ambient temperature 0~40°C • Humidity Below 70% RH The ambient temperature must be kept below 30°C. Even under ideal storage conditions, solderability of products electrodes may decrease as time passes. For this reason, inductors should be used within one year from the time of delivery. In case of storage over 6 months, solderability shall be checked before actual usage.
Technical considerations	<ul style="list-style-type: none"> ◆ Storage 1. Under a high temperature and humidity environment, problems such as reduced solderability caused by oxidation of terminal electrodes and deterioration of taping/packaging materials may take place.

* This catalog contains the typical specification only due to the limitation of space. When you consider purchase of our products, please check our specification. For details of each product (characteristics graph, reliability information, precautions for use, and so on), see our Web site (<http://www.ty-top.com/>) or CD catalogs.