

Phase Control SCR
900 Amperes Average
1800 Volts

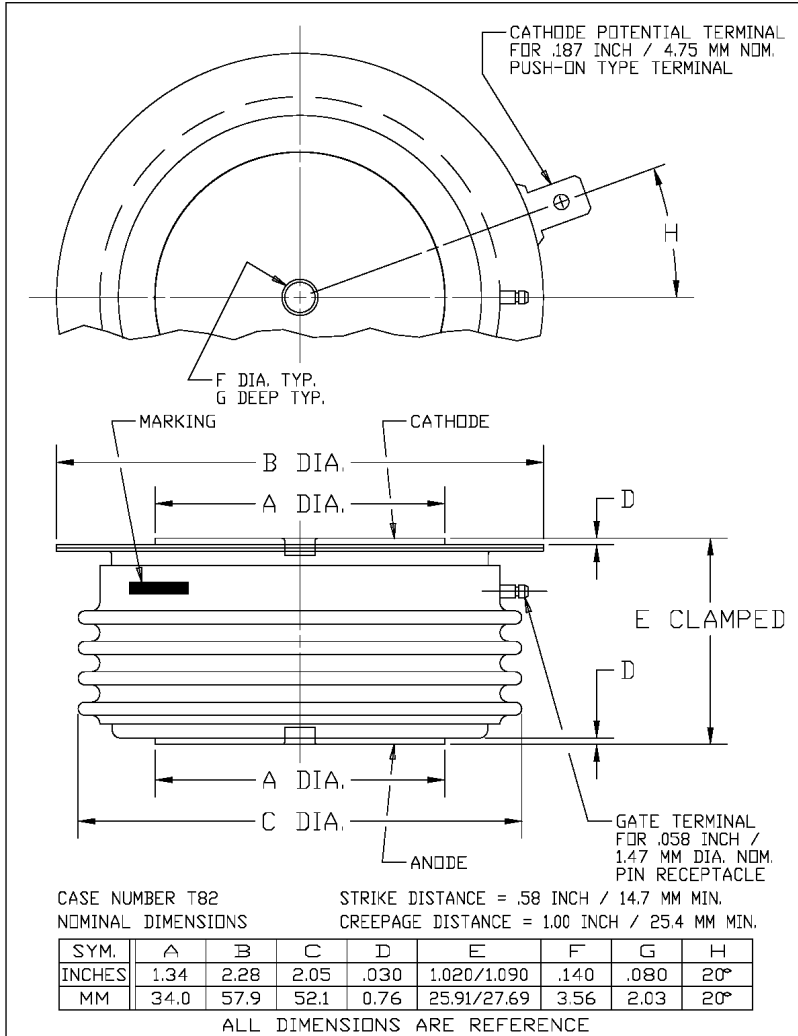

T820 900A (Outline Drawing)



T820 900A Phase Control SCR
900 Amperes Average, 1800 Volts

Description:

Powerex Silicon Controlled Rectifiers (SCR) are designed for phase control applications. These are all-diffused, Press-Pak, hermetic Pow-R-Disc devices employing the field proven amplifying gate.

Features:

- Low On-State Voltage
- High di/dt Capability
- High dv/dt Capability
- Hermetic Packaging
- Excellent Surge and I²t Ratings

Applications:

- Power Supplies
- Motor Control

Ordering Information:

Select the complete 12 digit module part number from the table below.
Example: T820169004DH is a 1600V 900A Phase Control SCR.

Type	Voltage V _{RRM} (Volts)	Current I _{T(av)} (A)	Turn-off Time t _q (µsec)	Gate Current I _{GT} (mA)	Lead Code
T820	02 through 18 200V through 1800V	90 900A	0 200 µsec (Typical)	4 150 mA	DH 12"

Absolute Maximum Ratings

Characteristics	Symbol		Units
Non-Repetitive Transient Peak Reverse Blocking Voltage	V_{RSM}	$V_{RRM} + 100V$	Volts
RMS On-State Current, $T_C = 70^\circ C$	$I_{T(RMS)}$	1410	Amperes
Average Current 180° Sine Wave, $T_C = 70^\circ C$	$I_{T(AV)}$	900	Amperes
RMS On-State Current, $T_C = 55^\circ C$	$I_{T(RMS)}$	1725	Amperes
Average Current 180° Sine Wave, $T_C = 55^\circ C$	$I_{T(AV)}$	1100	Amperes
Peak One Cycle Surge On-State Current (Non-Repetitive) 60 Hz	I_{TSM}	15,000	Amperes
Peak One Cycle Surge On-State Current (Non-Repetitive) 50 Hz	I_{TSM}	13,700	Amperes
Critical Rate-of-rise of On-State Current (Non-Repetitive)	di/dt	400	A/ μ sec
Critical Rate-of-rise of On-State Current (Repetitive)	di/dt	150	A/ μ sec
I^2t (for Fusing) for One Cycle, 60 Hz	I^2t	935,000	$A^2 \text{ sec}$
Peak Gate Power Dissipation	P_{GM}	16	Watts
Average Gate Power Dissipation	$P_{G(av)}$	3	Watts
Operating Temperature	T_J	-40 to +125	$^\circ C$
Storage Temperature	T_{stg}	-40 to +150	$^\circ C$
Approximate Weight		8	oz.
		227	g
Mounting Force		3000 to 3500	lb.
		1360 to 1590	kg.

Information presented is based upon manufacturers testing and projected capabilities.
This information is subject to change without notice.
The manufacturer makes no claim as to the suitability of use, reliability, capability,
or future availability of this product.

Electrical Characteristics, $T_J=25^\circ\text{C}$ unless otherwise specified

Characteristics	Symbol	Test Conditions	Min.	Typ.	Max.	Units
Repetitive Peak Reverse Leakage Current	I_{RRM}	$T_J=125^\circ\text{C}$, $V_R = V_{RRM}$			60	mA
Repetitive Peak Forward Leakage Current	I_{DRM}	$T_J=125^\circ\text{C}$, $V_D = V_{DRM}$			60	mA
Peak On-State Voltage	V_{TM}	$I_{FM}=1500\text{A peak}$, Duty Cycle < 0.1 %			1.35	V
Threshold Voltage, Low-level	$V_{(TO)1}$	$T_J = 125^\circ\text{C}$, $I = 15\%I_{T(AV)}$ to $\pi I_{T(AV)}$			0.78526	V
Slope Resistance, Low-level	r_{T1}				0.3505	$m\Omega$
Threshold Voltage, High-level	$V_{(TO)2}$	$T_J = 125^\circ\text{C}$, $I = \pi I_{T(AV)}$ to I_{TSM}			1.0789	V
Slope Resistance, High-level	r_{T2}				0.2311	$m\Omega$
V_{TM} Coefficients, Low-level		$T_J = 125^\circ\text{C}$, $I = 15\%I_{T(AV)}$ to $\pi I_{T(AV)}$ $V_{TM} = A + B \ln(I) + C(I) + D \text{ Sqrt}(I)$		A =	0.68865	
				B =	-0.04011	
				C =	-1.578 E-05	
				D =	0.025339	
V_{TM} Coefficients, High-level		$T_J = 125^\circ\text{C}$, $I = \pi I_{T(AV)}$ to I_{TSM} $V_{TM} = A + B \ln(I) + C(I) + D \text{ Sqrt}(I)$		A =	2.6289	
				B =	-0.37766	
				C =	8.873 E-05	
				D =	0.034055	
Typical Turn-On Time	t_{on}	$I_T = 1000\text{A}$, $V_D = 600\text{V}$		5		μs
Typical Turn-Off Time	t_q	$T_J = 125^\circ\text{C}$, $I_T = 250\text{A}$, $di_R/dt = 50\text{A}/\mu\text{s}$ Reapplied $dv/dt = 20\text{V}/\mu\text{s}$ Linear to 80% V_{DRM}		200		μs
Minimum Critical dv/dt – Exponential to V_{DRM}	dv/dt	$T_J = 125^\circ\text{C}$	300			$\text{V}/\mu\text{s}$
Gate Trigger Current	I_{GT}	$T_J = 25^\circ\text{C}$, $V_D = 12\text{V}$			150	mA
Gate Trigger Voltage	V_{GT}	$T_J = 25^\circ\text{C}$, $V_D = 12\text{V}$			3.0	V
Non-Triggering Gate Voltage	V_{GDM}	$T_J = 125^\circ\text{C}$, $V_D = V_{DRM}$			0.15	V
Peak Forward Gate Current	I_{GTM}				4	A
Peak Reverse Gate Voltage	V_{GRM}				5	V

Thermal Characteristics

Maximum Thermal Resistance, Double Sided Cooling		Max.	Units
Junction-to-Case	$R_{\theta(J-C)}$	0.037	$^\circ\text{C}/\text{W}$
Case-to-Sink	$R_{\theta(C-S)}$	0.020	$^\circ\text{C}/\text{W}$

Maximum On-State Forward Voltage Drop
($T_j = 125^\circ\text{C}$)

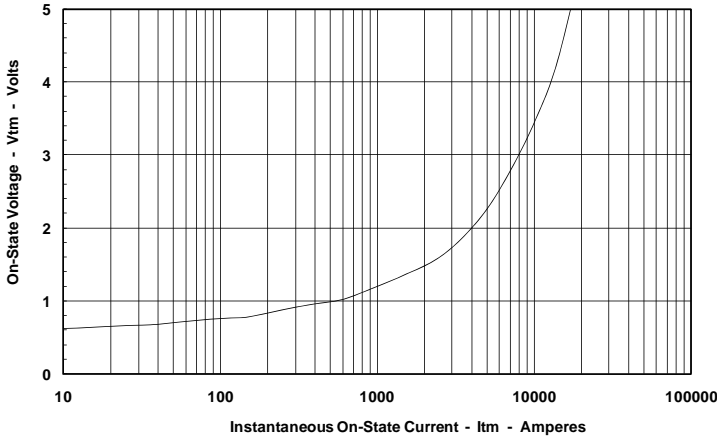

Maximum Transient Thermal Impedance
(Junction to Case)

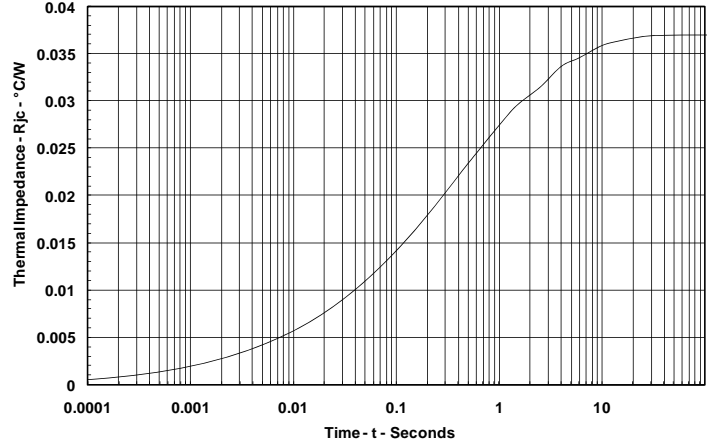

Maximum On-State Power Dissipation
(Sinusoidal Waveform)

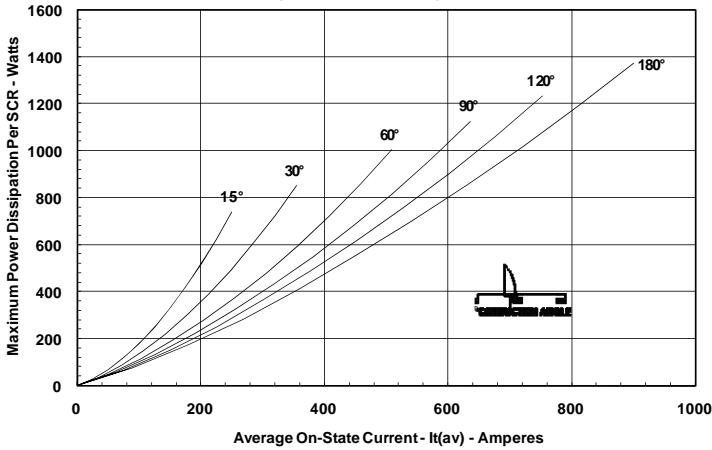

Maximum Allowable Case Temperature
(Sinusoidal Waveform)

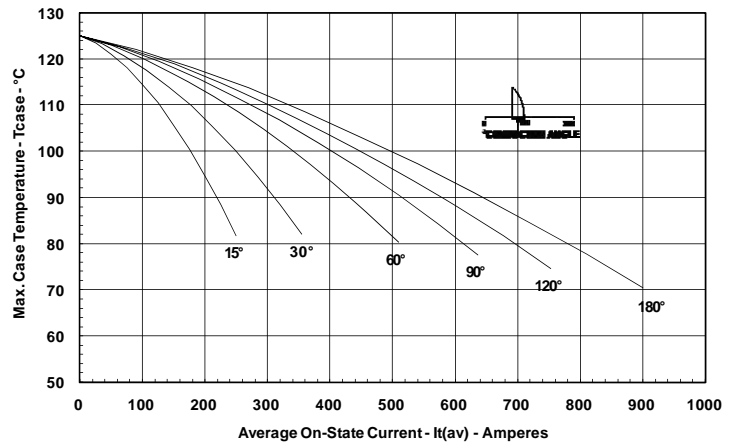

Maximum On-State Power Dissipation
(Rectangular Waveform)

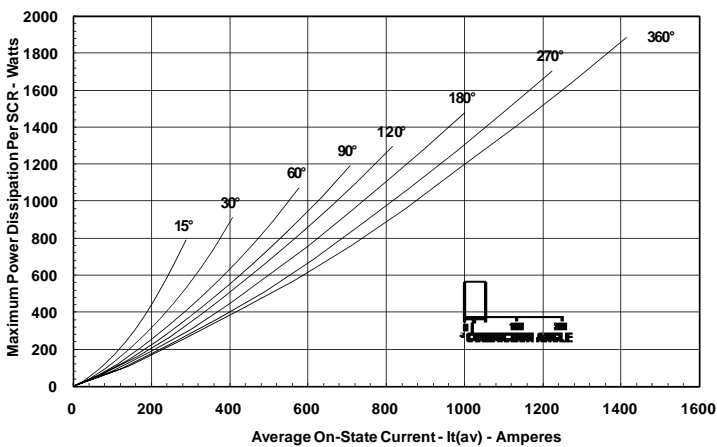

Maximum Allowable Case Temperature
(Rectangular Waveform)

