

SOLID TANTALUM CHIP CAPACITORS

T495 SERIES—Low ESR, Surge Robust



Solid Tantalum Surface Mount

FEATURES

- Designed for very low ESR
- High ripple current capability
- High surge current capability
- 100% accelerated steady-state aging
- 100% Surge Current test
- Meets or Exceeds EIA Standard 535BAAC
- Available tested per DSCC Dwg. 95158
- Operating Temperature: -55°C to +125°C
- New Extended Values for Low ESR
- Low Equivalent Series Inductance (<2.5nH ESL)
- Precision-molded, laser-marked case
- Symmetrical, compliant terminations
- Taped and reeled per EIA 481-1
- RoHS Compliant & Leadfree Terminations (see www.kemet.com for lead transition)

OUTLINE DRAWING

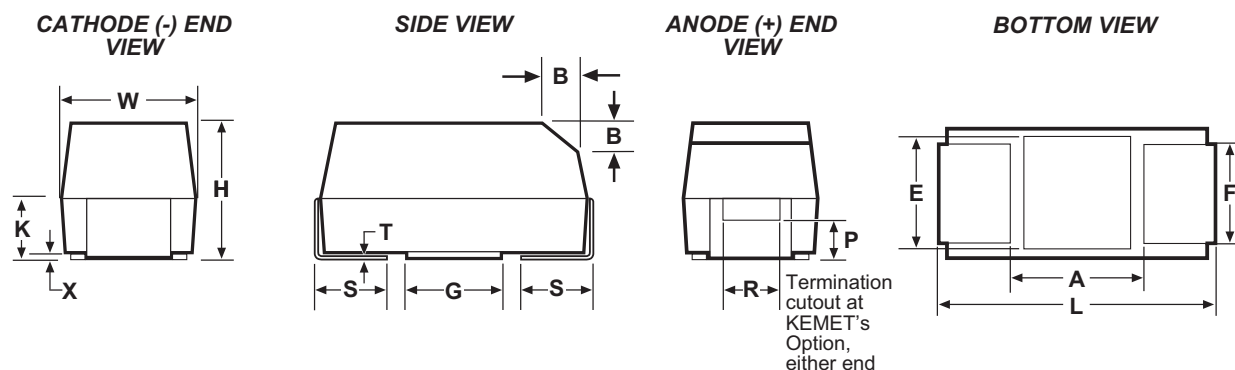

STANDARD T495 DIMENSIONS

Millimeters (Inches)

Case Size		L	W	H	K ±0.20	F ±0.1	S ±0.3	B ±0.15 (Ref) ±.006	X (Ref)	P (Ref)	R (Ref)	T (Ref)	A (Min)	G (Ref)	E (Ref)
KEMET	EIA														
B	3528-21	3.5 ± 0.2 (.138 ± .008)	2.8 ± 0.2 (.110 ± .008)	1.9 ± 0.1 (.075 ± .008)	1.1 (.043)	2.2 (.087)	0.8 (.031)	0.4 (.016)	0.10 ± 0.10 (.004 ± .004)	0.5 (.020)	1.0 (.039)	0.13 (.005)	2.1 (.083)	1.8 (.071)	2.2 (.087)
C	6032-28	6.0 ± 0.3 (.236 ± .012)	3.2 ± 0.3 (.126 ± .012)	2.5 ± 0.3 (.098 ± .012)	1.4 (.055)	2.2 (.087)	1.3 (.051)	0.5 (.020)	0.10 ± 0.10 (.004 ± .004)	0.9 (.0235)	1.0 (.039)	0.13 (.005)	3.1 (.122)	2.8 (.110)	2.4 (.094)
D	7343-31	7.3 ± 0.3 (.287 ± .012)	4.3 ± 0.3 (.169 ± .012)	2.8 ± 0.3 (.110 ± .012)	1.5 (.059)	2.4 (.094)	1.3 (.051)	0.5 (.020)	0.10 ± 0.10 (.004 ± .004)	0.9 (.0235)	1.0 (.039)	0.13 (.005)	3.8 (.150)	3.5 (.138)	3.5 (.138)
X	7343-43	7.3 ± 0.3 (.287 ± .012)	4.3 ± 0.3 (.169 ± .012)	4.0 ± 0.3 (.157 ± .012)	2.3 (.091)	2.4 (.094)	1.3 (.051)	0.5 (.020)	0.10 ± 0.10 (.004 ± .004)	1.7 (.067)	1.0 (.039)	0.13 (.005)	3.8 (.150)	3.5 (.138)	3.5 (.138)
E	7260-38	7.3 ± 0.3 (.287 ± .012)	6.0 ± 0.3 (.236 ± .012)	3.6 ± 0.2 (.142 ± .008)	2.3 (.091)	4.1 (.161)	1.3 (.051)	0.5 (.020)	0.10 ± 0.10 (.004 ± .004)	0.9 (.035)	1.0 (.039)	0.13 (.005)	3.8 (.150)	3.5 (.138)	3.5 (.138)

Notes: 1. Metric dimensions govern.
2. (Ref) - Dimensions provided for reference only.

LOW PROFILE T495 DIMENSIONS

Millimeters (Inches)

CASE SIZE		COMPONENT										
KEMET	EIA	L	W	H Max.	K Min.	F ± 0.1	S ± 0.3	X (Ref)	T (Ref)	A (Min)	G (Ref)	E (Ref)
T	3528-12	3.5 ± 0.2 (.138 ± .008)	2.8 ± 0.2 (.110 ± .008)	1.2 (.047)	0.3 (.012)	2.2 (.087)	0.8 (.031)	0.05 (.002)	0.13 (.005)	2.1 (.083)	1.8 (.071)	2.2 (.087)
V	7343-20	7.3 ± 0.3 (.287 ± .012)	4.3 ± 0.3 (.169 ± .012)	2.0 (0.079)	0.9 (.035)	2.4 (.094)	1.3 (.051)	0.05 (.002)	0.13 (.005)	3.8 (.150)	3.5 (.138)	3.5 (.138)

Notes: 1. Metric dimensions govern.
2. (Ref) - Dimensions provided for reference only.
3. No dimensions provided for B, P or R because low profile cases do not have a bevel or a notch.

T495 Series – ORDERING INFORMATION

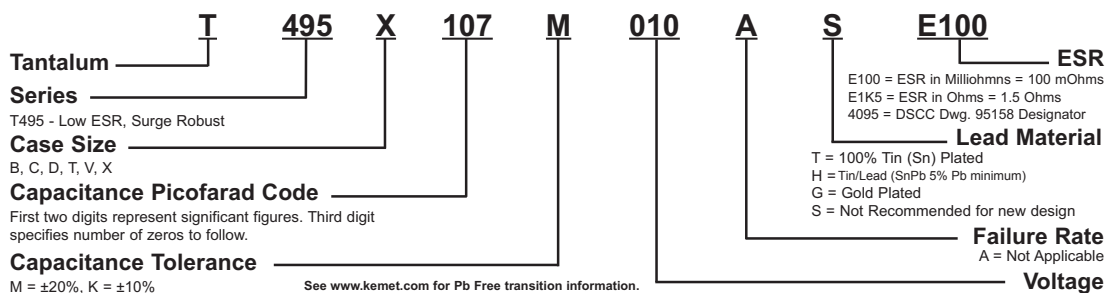

T495 RATINGS & PART NUMBER REFERENCE

Capacitance μ F	Case Size	KEMET Part Number	DSCC Dwg. No. 95158 Part Number	DC Leakage μ A @ 25°C Max	DF% @ 25°C 120 Hz Max	ESR m Ω @ 25°C 100 kHz Max	Ripple Current mA rms @ 25°C, 100 kHz Max		
							25°C	85°C	125°C
							2.5 Volt Rating @ +85°C (1.7 Volt Rating at +125°C)		
100.0	T	T495T107M2R5A(2)E3K0		2.5	24.0	3000	153	137	61
220.0	D	T495D227(1)J2R5A(2)E045		5.5	8.0	45	1826	1643	730
1000.0	X	T495X108(1)J2R5A(2)E040		25.0	15.0	40	2031	1828	812
4 Volt Rating @ +85°C (2.7 Volt Rating at +125°C)									
68.0	V	T495V686(1)J004A(2)E150		2.7	6.0	150	913	822	365
100.0	B	T495B107(1)J004A(2)E300		4.0	8.0	500	412	371	165
150.0	B	T495B157M006A(2)E900		6.0	12.0	900	307	277	123
150.0	C	T495C157(1)J004A(2)E250		6.0	8.0	250	663	597	265
330.0	C	T495C337(1)J004A(2)E300		13.2	10.0	300	606	545	242
330.0	C	T495C337(1)J004A(2)E700		13.2	12.0	700	396	357	159
330.0	D	T495D337(1)J004A(2)E030		13.2	8.0	30	2236	2012	894
330.0	D	T495D337(1)J004A(2)E045		13.2	8.0	45	1826	1643	730
470.0	X	T495X477(1)J004A(2)E030		18.8	8.0	30	2345	2111	938
470.0	X	T495X477(1)J004A(2)E045		18.8	8.0	45	1915	1723	766
470.0	X	T495X477(1)J004A(2)E100		18.8	8.0	100	1285	1156	514
1000.0	X	T495X108(1)J004A(2)E070		40.0	12.0	70	1535	1381	614
1000.0	E	T495E108(1)J004A(2)E035		40.0	15.0	35	2326	2151	956
1000.0	E	T495E108(1)J004A(2)E050		40.0	15.0	50	2000	1800	800
6/6.3 Volt Rating @ +85°C (4 Volt Rating at +125°C)									
47.0	B	T495B476(1)J006A(2)E450		3.0	6.0	450	435	392	174
47.0	C	T495C476(1)J006A(2)E250		2.9	6.0	250	663	597	265
47.0	V	T495V476(1)J006A(2)E150		3.0	6.0	150	913	822	365
68.0	D	T495D686(1)J006A(2)E175		3.3	4.0	175	926	833	370
68.0	D	T495D686(1)J006A(2)4095	95158-01(1)2	3.3	4.0	175	926	833	370
100.0	*B	T495B107(1)J006A(2)E400		6.3	15.0	400	461	415	184
100.0	*B	T495B107M006A(2)E700		6.3	15.0	700	348	313	139
100.0	C	T495C107(1)J006A(2)E150		6.0	8.0	150	856	770	342
100.0	D	T495D107(1)J006A(2)E150		6.0	8.0	150	1000	900	400
100.0	V	T495V107(1)J006A(2)E080		6.0	8.0	90	1179	1061	471
100.0	V	T495V107(1)J006A(2)E150		6.0	8.0	150	913	822	365
150.0	*C	T495C157M006A(2)E200		9.0	8.0	200	742	668	297
150.0	V	T495V157(1)J006A(2)E070		9.0	8.0	70	1336	1203	535
150.0	X	T495X157(1)J006A(2)E100		7.2	6.0	100	1285	1156	514
150.0	X	T495X157(1)J006A(2)4095	95158-02(1)2	7.2	6.0	125	1150	1040	460
220.0	*C	T495C227(1)J006A(2)E225		13.9	10.0	225	700	600	300
220.0	D	T495D227(1)J006A(2)E045		13.2	8.0	45	1826	1643	730
220.0	D	T495D227(1)J006A(2)E100		13.9	8.0	100	1225	1102	490
220.0	D	T495D227(1)J006A(2)4095	95158-25(1)2	13.2	8.0	100	1225	1102	490
220.0	X	T495X227(1)J006A(2)E070		13.2	8.0	70	1535	1381	614
230.0	X	T495X227(1)J006A(2)E150		13.2	8.0	100	1285	1156	514
220.0	X	T495X227(1)J006A(2)4095	95158-03(1)2	13.2	8.0	100	1285	1156	514
330.0	D	T495D337(1)J006A(2)E040		20.8	8.0	40	1936	1743	775
330.0	D	T495D337(1)J006A(2)E050		20.8	8.0	50	1732	1559	693
330.0	D	T495D337(1)J006A(2)E070		20.8	8.0	70	1464	1317	586
330.0	D	T495D337(1)J006A(2)E100		20.8	8.0	100	1225	1102	490
330.0	X	T495X337(1)J006A(2)E065		19.8	8.0	65	1593	1434	637
330.0	*X	T495X337(1)J006A(2)E045		19.8	8.0	45	1915	1723	766
330.0	*X	T495X337(1)J006A(2)E100		19.8	8.0	100	1285	1156	514
330.0	*E	T495E337(1)J006A(2)E080		20.8	8.0	60	1826	1643	730
330.0	*E	T495E337(1)J006A(2)E100		20.8	8.0	100	1414	1273	566
470.0	*D	T495D477(1)J006A(2)E100		29.6	12.0	100	1225	1102	490
470.0	*D	T495D477(1)J006A(2)E125		29.6	12.0	125	1095	986	438
470.0	X	T495X477(1)J006A(2)E030		28.2	10.0	30	2345	2111	938
470.0	X	T495X477(1)J006A(2)E045		28.2	10.0	45	1915	1723	766
470.0	*X	T495X477(1)J006A(2)E050		28.2	10.0	50	1816	1634	726
470.0	*X	T495X477(1)J006A(2)E065		28.2	10.0	65	1593	1434	637
470.0	*E	T495E477(1)J006A(2)E055		29.6	10.0	55	1907	1716	763
470.0	*E	T495E477(1)J006A(2)E100		29.6	10.0	100	1414	1273	566
1000.0	*E	T495E108(1)J006A(2)E050		63.0	15.0	50	2000	1800	800
10 Volt Rating @ +85°C (7 Volt Rating at +125°C)									
4.7	A	T495A475(1)J010A(2)E1K3		0.5	6.0	1300	240	216	96
4.7	B	T495B475(1)J010A(2)E1K3		0.5	15.0	1300	256	230	102
6.8	A	T495A685(1)J010A(2)E1K8		0.7	6.0	1800	204	184	82
6.8	B	T495B685(1)J010A(2)E900		0.7	6.0	900	307	277	123
10.0	B	T495B106(1)J010A(2)E750		1.0	6.0	750	337	303	135
15.0	B	T495B156(1)J010A(2)E500		1.5	6.0	500	412	371	165
15.0	C	T495C156(1)J010A(2)E375		1.5	6.0	375	542	487	217
15.0	C	T495C156(1)J010A(2)E400		1.5	6.0	400	524	472	210
15.0	C	T495C156(1)J010A(2)E475		1.5	6.0	475	481	433	192
22.0	C	T495C226(1)J010A(2)E290		2.2	6.0	290	616	554	246
22.0	C	T495C226(1)J010A(2)E345		2.2	6.0	345	565	508	226
33.0	B	T495B336(1)J010A(2)E450		3.3	6.0	450	435	392	174
33.0	V	T495V336(1)J010A(2)E100		3.3	6.0	100	1118	1006	447
33.0	V	T495V336(1)J010A(2)E150		3.3	6.0	150	913	822	365
47.0	D	T495D476(1)J010A(2)E080		3.8	4.0	80	1369	1232	548
47.0	D	T495D476(1)J010A(2)E090		4.7	6.0	90	1291	1162	516
47.0	D	T495D476(1)J010A(2)E200		3.8	4.0	200	866	780	346
47.0	D	T495D476(1)J010A(2)4095	95158-04(1)2	3.8	4.0	200	866	780	346
68.0	B	T495B686(1)J010A(2)E600		6.8	10.0	600	376	339	151
68.0	B	T495B686(1)J010A(2)E750		1.5	10.0	750	337	303	135
68.0	*B	T495B686M010A(2)E900		6.8	10.0	900	307	276	123
68.0	C	T495C686(1)J010A(2)E225		6.8	6.0	225	700	630	280
68.0	V	T495V686(1)J010A(2)E070		6.8	6.0	70	1336	1203	535
68.0	V	T495V686(1)J010A(2)E100		6.8	6.0	100	1118	1006	447
68.0	V	T495V686(1)J010A(2)E140		6.8	6.0	140	945	850	378
68.0	D	T495D686(1)J010A(2)E090		6.8	6.0	90	1291	1162	516
68.0	D	T495D686(1)J010A(2)E150		6.8	6.0	150	1000	900	400
68.0	X	T495X686(1)J010A(2)E150		5.4	4.0	150	1049	944	420
68.0	X	T495X686(1)J010A(2)4095	95158-05(1)2	5.4	4.0	150	1049	944	420
100.0	V	T495V107(1)J010A(2)E150		10.0	8.0	150	913	822	365
100.0	*D	T495D107(1)J010A(2)E065		10.0	8.0	65	1519	1367	608
100.0	*D	T495D107(1)J010A(2)E080		10.0	8.0	80	1369	1232	548
100.0	D	T495D107(1)J010A(2)E100		10.0	8.0	100	1220	1100	490
100.0	D	T495D107(1)J010A(2)4095	95158-06(1)2	10.0	8.0	100	1220	1100	490
100.0	X	T495X107(1)J010A(2)E100		8.0	6.0	100	1285	1156	514
100.0	X	T495X107(1)J010A(2)4095	95158-07(1)2	8.0	6.0	100	1285	1156	514
150.0	V	T495V157(1)J010A(2)E100		15.0	8.0	100	1118	1006	447
150.0	*V	T495V157M010A(2)E150		15.0	8.0	150	913	822	365
150.0	D	T495D157(1)J010A(2)E080		15.0	8.0	80	1369	1232	548
150.0	D	T495D157(1)J010A(2)E100		15.0	8.0	100	1225	1102	490
150.0	D	T495D157(1)J010A(2)4095	95158-26(1)2	15.0	8.0	100	1225	1102	490
150.0	X	T495X157(1)J010A(2)E085		15.0	8.0	85	1393	1254	557
150.0	X	T495X157(1)J010A(2)E100		15.0	8.0	100	1285	1156	514
150.0	X	T495X157(1)J010A(2)4095	95158-08(1)2	15.0	8.0	100	1285	1156	514
220.0	*V	T495V227(1)J010A(2)E150		22.0	12.0	150	913	822	365
220.0	D	T495D227(1)J010A(2)E045		22.0	8.0	45	1826	1643	730
220.0	D	T495D227(1)J010A(2)E075		22.0	8.0	75	1414	1273	566
220.									

SOLID TANTALUM CHIP CAPACITORS

T495 SERIES—Low ESR, Surge Robust



Solid Tantalum Surface Mount

T495 RATINGS & PART NUMBER REFERENCE

Capacitance μ F	Case Size	KEMET Part Number	DSCC Dwg. No. 95158 Part Number	DC Leakage μ A @ 25°C Max	DF% @ 25°C 120 Hz Max	ESR m Ω @ 100 kHz Max	Ripple Current mA rms @ 25°C, 100 kHz Max		
							25°C	85°C	125°C
10 Volt Rating @ +85°C (7 Volt Rating at +125°C) cont.									
330.0	D	T495D337(1)010A(2)E125		33.0	10.0	125	1095	986	438
330.0	X	T495X337(1)010A(2)E035		33.0	10.0	35	2171	1954	868
330.0	X	T495X337(1)010A(2)E050		33.0	10.0	50	1817	1635	727
330.0	X	T495X337(1)010A(2)E060		33.0	10.0	60	1658	1492	663
330.0	E	T495E337(1)010A(2)E040		33.0	8.0	40	2236	2012	894
330.0	E	T495E337(1)010A(2)E060		33.0	10.0	60	1826	1643	730
330.0	E	T495E337(1)010A(2)E100		33.0	10.0	100	1414	1273	566
16 Volt Rating @ +85°C (10 Volt Rating at +125°C)									
3.3	A	T495A335(1)016A(2)E3K0		0.5	6.0	3000	158	142	63
4.7	A	T495A475(1)016A(2)E2K0		0.8	6.0	2000	194	174	77
4.7	B	T495B475(1)016A(2)E700		0.8	6.0	700	348	313	139
6.8	C	T495C685(1)016A(2)E750		1.1	6.0	750	383	345	153
10.0	T	T495T106M016A(2)E4K0		1.6	8.0	4000	132	119	53
15.0	B	T495B156(1)016A(2)E800		2.4	6.0	800	326	293	130
33.0	C	T495C336(1)016A(2)E225		5.3	6.0	225	699	629	280
33.0	C	T495C336(1)016A(2)E275		5.3	6.0	275	632	569	253
33.0	D	T495D336(1)016A(2)E150		6.6	6.0	150	1000	900	400
33.0	D	T495D336(1)016A(2)E175		5.3	6.0	175	926	833	370
33.0	D	T495D336(1)016A(2)E225		4.2	4.0	225	816	735	327
33.0	D	T495D336(1)016A(2)4095	95158-09(1)2	4.2	4.0	250	770	700	310
47.0	C	T495C476(1)016A(2)E350		7.5	6.0	350	561	505	224
47.0	D	T495D476(1)016A(2)E100		7.5	6.0	100	1225	1102	490
47.0	D	T495D476(1)016A(2)E150		7.5	6.0	150	1000	900	400
47.0	D	T495D476(1)016A(2)4095	95158-10(1)2	7.5	6.0	200	870	780	345
68.0	V	T495V686(1)016A(2)E180		10.9	6.0	180	833	750	333
68.0	V	T495V686(1)016A(2)E300		10.9	6.0	300	645	581	258
68.0	D	T495D686(1)016A(2)E150		10.9	6.0	150	1000	900	400
100.0	D	T495D107(1)016(2)E100		16.0	8.0	100	1225	1102	490
100.0	D	T495D107(1)016A(2)E125		16.0	8.0	125	1095	986	438
100.0	X	T495X107(1)016A(2)E080		16.0	8.0	80	1436	1293	574
100.0	X	T495X107(1)016A(2)E100		16.0	8.0	100	1285	1156	514
100.0	X	T495X107(1)016A(2)4095	95158-11(1)2	16.0	8.0	125	1149	1034	460
150.0	X	T495X157(1)016A(2)E075		24.0	8.0	75	1483	1335	593
150.0	X	T495X157(1)016A(2)E100		24.0	8.0	100	1285	1156	514
220.0	E	T495E227(1)016A(2)E100		35.2	7.2	100	1414	1273	566
220.0	E	T495E227(1)016A(2)E150		35.2	7.2	150	1155	1039	462
20 Volt Rating @ +85°C (13 Volt Rating at +125°C)									
1.0	A	T495A105(1)020A(2)E3K0		0.2	4.0	3000	158	142	63
10.0	B	T495B106(1)020A(2)E1K0		2.0	6.0	1000	292	262	117
10.0	C	T495C106(1)020A(2)E400		2.0	6.0	400	524	472	210
10.0	C	T495C106(1)020A(2)E475		2.0	6.0	475	481	433	192
15.0	C	T495D156(1)020A(2)E375		3.0	6.0	375	542	487	217
15.0	D	T495D156(1)020A(2)E275		2.4	4.0	275	738	665	295
15.0	D	T495D156(1)020A(2)4095	95158-12(1)2	2.4	4.0	275	738	665	295
22.0	D	T495D226(1)020A(2)E180		3.5	4.0	180	913	822	365
22.0	D	T495D226(1)020A(2)E225		3.5	4.0	225	816	735	326
22.0	D	T495D226(1)020A(2)4095	95158-13(1)2	3.5	4.0	275	739	665	295
33.0	D	T495D336(1)020A(2)E100		6.6	6.0	100	1225	1102	490
33.0	D	T495D336(1)020A(2)E150		6.6	6.0	150	1000	900	400
33.0	D	T495D336(1)020A(2)E200		6.6	6.0	200	866	780	346
47.0	D	T495D476(1)020A(2)E100		9.4	6.0	100	1225	1102	490
47.0	D	T495D476(1)020A(2)E175		9.4	6.0	175	926	833	370
47.0	X	T495X476(1)020A(2)E065		9.4	8.0	65	1593	1434	637
47.0	X	T495X476(1)020A(2)E100		9.4	6.0	100	1285	1156	514
47.0	X	T495X476(1)020A(2)E125		9.4	6.0	125	1149	1034	460
47.0	X	T495X476(1)020A(2)E150		7.5	4.0	150	1049	944	420
47.0	X	T495X476(1)020A(2)4095	95158-14(1)2	7.5	4.0	150	1049	944	420
68.0	D	T495D686(1)020A(2)E150		13.6	8.0	150	1000	900	400
68.0	X	T495X686(1)020A(2)E120		13.6	6.0	120	1173	1055	469
68.0	X	T495X686(1)020A(2)E150		13.6	6.0	150	1049	944	420
68.0	X	T495X686(1)020A(2)4095	95158-15(1)2	13.6	6.0	150	1049	944	420
100.0	X	T495E107(1)020A(2)E150		20.0	8.0	150	1049	944	420
100.0	E	T495E107(1)020A(2)E085		20.0	8.0	85	1534	1381	614
100.0	E	T495E107(1)020A(2)E100		20.0	8.0	100	1414	1273	566
100.0	E	T495E107(1)020A(2)E200		20.0	8.0	200	1000	900	400
25 Volt Rating @ +85°C (17 Volt Rating at +125°C)									
0.47	A	T495A474(1)025A(2)E4K5		0.5	4.0	4500	129	116	52
2.2	C	T495C225(1)025A(2)E1K3		0.6	6.0	1300	291	262	116
3.3	C	T495C335(1)025A(2)E750		0.9	6.0	750	383	345	153
4.7	C	T495C475(1)025A(2)E575		1.2	6.0	575	437	394	175
6.8	B	T495B685(1)025A(2)E1K5		1.7	6.0	1500	238	214	95
6.8	C	T495C685(1)025A(2)E400		1.7	6.0	400	524	472	210
6.8	C	T495C685(1)025A(2)E490		1.7	6.0	490	474	426	190
6.8	C	T495C685(1)025A(2)E500		1.7	6.0	500	469	422	188
10.0	C	T495C106(1)025A(2)E450		2.5	6.0	450	494	445	198
15.0	D	T495D156(1)025A(2)E275		3.8	6.0	275	738	665	295
15.0	D	T495D156(1)025A(2)4095	95158-16(1)2	3.8	6.0	275	738	665	295
15.0	X	T495X156(1)025A(2)E200		3.0	4.0	200	908	817	363
15.0	X	T495X156(1)025A(2)4095	95158-17(1)2	3.0	4.0	200	908	817	363
22.0	C	T495C226(1)025A(2)E300		5.5	8.0	300	606	545	242
22.0	C	T495C226(1)025A(2)E900		5.5	6.0	900	350	315	140
22.0	D	T495D226(1)025A(2)E200		5.5	6.0	200	866	780	346
22.0	X	T495X226(1)025A(2)E225		4.4	4.0	225	856	771	343
22.0	X	T495X226(1)025A(2)4095	95158-18(1)2	4.4	4.0	225	856	771	343
33.0	D	T495D336(1)025A(2)E090		8.3	6.0	90	1291	1162	516
33.0	D	T495D336(1)025A(2)E100		8.3	6.0	100	1225	1102	490
33.0	D	T495D336(1)025A(2)E225		8.3	6.0	225	816	735	327
33.0	D	T495D336(1)025A(2)E300		8.3	6.0	300	707	636	283
33.0	X	T495X336(1)025A(2)E175		6.6	4.0	175	971	874	388
33.0	X	T495X336(1)025A(2)4095	95158-19(1)2	6.6	4.0	175	971	874	388
47.0	X	T495X476M025A(2)E150		11.8	6.0	150	1049	944	420
47.0	X	T495X476M025A(2)E185		16.5	8.0	185	944	850	378
47.0	X	T495X476M025A(2)E200		11.8	6.0	200	908	817	363
47.0	D	T495D476M025(2)E120		11.8	10.0	120	1118	1006	447
47.0	D	T495D476(1)025(2)E250		11.8	10.0	250	775	697	310
68.0	X	T495X686(1)025A(2)E125		17.0	8.0	125	1149	1034	460
68.0	X	T495X686(1)025A(2)E150		17.0	8.0	150	1049	944	420
68.0	X	T495X686(1)025A(2)E200		17.0	8.0	200	908	817	363

- To complete KEMET part number, insert "K" for $\pm 10\%$ or "M" for $\pm 20\%$ capacitance tolerance.
 - To complete KEMET part number, insert lead material designations per Ordering Information on page 31.
- *Extended Values

Higher voltage ratings and tighter capacitance tolerance product may be substituted within the same size at KEMET's option. Voltage substitutions will be marked with the higher voltage rating.

T495 RATINGS & PART NUMBER REFERENCE

Capacitance μ F	Case Size	KEMET Part Number	DSCC Dwg. No. 95158 Part Number	DC Leakage μ A @ 25°C Max	DF% @ 25°C 120 Hz Max	ESR m Ω @ 25°C 100 kHz Max	Ripple Current mA rms @ 25°C, 100 kHz Max		
							25°C	85°C	125°C
35 Volt Rating @ +85°C (23 Volt Rating at +125°C)									
0.47	B	T495B474(1)035A(2)E1K5		0.5	4.0	1500	238	214	95
0.47	B	T495B474(1)035A(2)E2K2		0.5	4.0	2200	197	177	79
1.0	A	T495A105(1)035A(2)E3K0		0.4	4.0	3000	158	142	63
1.0	B	T495B105(1)035A(2)E1K5		0.5	4.0	1500	238	214	95
1.0	B	T495B105(1)035A(2)E1K7		0.5	4.0	1700	224	201	89
2.2	B	T495B225(1)035A(2)E1K5		0.8	6.0	1500	238	214	95
2.2	C	T495C225(1)035A(2)E750		0.8	6.0	750	383	345	153
3.3	B	T495B335(1)035A(2)E900		1.2	6.0	900	307	276	123
3.3	C	T495C335(1)035A(2)E600		1.2	6.0	600	428	385	171
4.7	C	T495C475(1)035A(2)E450		1.7	6.0	450	494	445	198
4.7	C	T495C475(1)035A(2)E500		1.7	6.0	500	469	422	188
4.7	*C	T495C475(1)035A(2)E600		1.7	6.0	600	428	385	171
4.7	*C	T495C475(1)035A(2)4095	95158-29(1)2	1.7	6.0	600	428	385	171
6.8	D	T495D685(1)035A(2)E400		2.4	6.0	400	612	551	245
6.8	X	T495X685(1)035A(2)E300		1.9	4.0	300	742	667	297
6.8	X	T495X685(1)035A(2)4095	95158-20(1)2	1.9	4.0	300	742	667	297
10.0	D	T495D106(1)035A(2)E250		3.5	6.0	250	775	697	310
10.0	D	T495D106(1)035A(2)E300		3.5	6.0	300	707	636	283
10.0	D	T495D106(1)035A(2)4095	95158-27(1)2	3.5	4.0	300	707	636	283
10.0	X	T495X106(1)035A(2)E175		3.5	6.0	175	971	874	388
10.0	X	T495X106(1)035A(2)E200		3.5	6.0	200	908	817	363
10.0	X	T495X106(1)035A(2)E250		2.8	4.0	250	812	731	325
10.0	X	T495X106(1)035A(2)4095	95158-21(1)2	2.8	4.0	250	812	731	325
15.0	D	T495D156(1)035A(2)E225		5.3	6.0	225	816	735	327
15.0	*D	T495D156(1)035A(2)E300		5.3	6.0	300	707	636	283
15.0	*X	T495X156(1)035A(2)E200		5.3	6.0	200	908	817	363
15.0	*X	T495X156(1)035A(2)E225		5.3	6.0	225	856	771	343
15.0	*X	T495X156(1)035A(2)4095	95158-22(1)2	5.3	6.0	225	856	771	343
22.0	D	T495D226(1)035A(2)E200		7.7	6.0	200	866	779	346
22.0	D	T495D226(1)035A(2)E250		7.7	6.0	250	775	697	310
22.0	*D	T495D226(1)035A(2)E300		7.7	6.0	300	707	636	283
22.0	X	T495X226(1)035A(2)E200		7.7	6.0	200	908	817	363
22.0	*X	T495X226(1)035A(2)E275		7.7	6.0	275	775	697	410
22.0	*X	T495X226(1)035A(2)4095	95158-23(1)2	7.7	6.0	300	742	667	297
33.0	X	T495X336(1)035A(2)E175		11.6	6.0	175	971	874	388
33.0	*X	T495X336(1)035A(2)E250		11.6	6.0	250	812	731	325
47.0	X	T495X476(1)035A(2)E185		16.5	8.0	185	944	850	378
47.0	X	T495X476(1)035A(2)E200		16.5	8.0	200	908	817	363
47.0	*X	T495X476(1)035A(2)E300		16.5	8.0	300	742	667	297
50 Volt Rating @ +85°C (33 Volt Rating at +125°C)									
1.0	C	T495C105(1)050A(2)E1K3		0.5	4.0	1300	291	262	116
2.2	D	T495D225(1)050A(2)E600		1.1	6.0	600	500	450	200
3.3	D	T495D335(1)050A(2)E700		1.7	6.0	700	463	417	185
4.7	D	T495D475(1)050A(2)E275		2.4	6.0	275	739	665	295
4.7	D	T495D475(1)050A(2)E300		2.4	6.0	300	707	636	283
4.7	X	T495X475(1)050A(2)E300		1.9	4.0	300	742	667	297
4.7	X	T495X475(1)050A(2)4095	95158-24(1)2	1.9	4.0	300	742	667	297
6.8	D	T495D685(1)050A(2)E275		3.4	6.0	275	739	665	295
6.8	*D	T495D685(1)050A(2)E300		3.4	8.0	300	700	600	300
10.0	*X	T495X106(1)050A(2)E300		5.0	6.0	300	741	667	297
15.0	*X	T495X156(1)050A(2)E300		7.5	8.0	300	742	667	297

- (1) To complete KEMET part number, insert "K" for $\pm 10\%$ or "M" for $\pm 20\%$ capacitance tolerance.
 (2) To complete KEMET part number, insert lead material designations per Ordering Information on page 31.
 *Extended Values

Higher voltage ratings and tighter capacitance tolerance product may be substituted within the same size at KEMET's option. Voltage substitutions will be marked with the higher voltage rating.

CONSTRUCTION

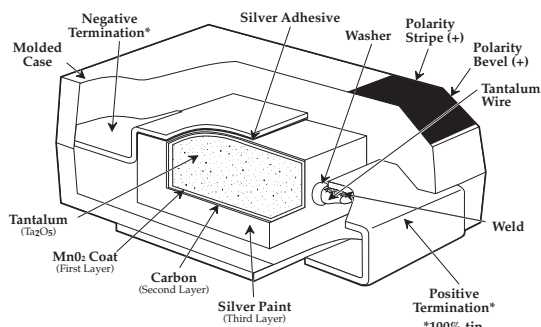

CAPACITOR MARKINGS

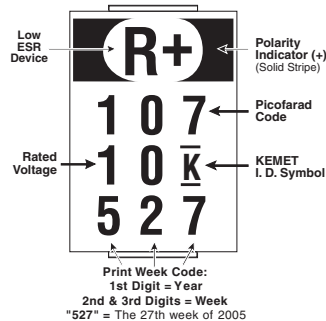

T495 TANTALUM CHIP CAPACITANCE VALUES

Case Size and Max. ESR (mΩ) by Capacitance & Voltage
Standard Capacitance Values

Capacitance		Rated Voltage @ +85°C								
μF	Code	2.5	4	6	10	16	20	25	35	50
0.47	474							A,4500	B,1500 B,2200	
1.0	105						A,3000		A,3000 B,1500 B,1700	C,1500
2.2	225							C,1300	B,1500 C,750	D,600
3.3	335					A,3000		C,750	B,900 C,600	D,700
4.7	475				A,1300 B,1300	A,2000 B,700		C,575	C,450,500 C,600	D,275,300 X,300
6.8	685				A,1800 B,900	C,750		B,1500 C,400,490,500	D,400 X,300	D,275,300
10.0	106				B,750	T,4000	B,1000 C,400,475	C,450	D,250,300 X,175,200 X,250	X,300
15.0	156				B,500 C,375,400	B,800	C,375 D,275	D,275 X,200	D,225,300 X,200,225	X,300
22.0	226				V,70 C,290,345		D,180,225 D,275	C, 300,900 D,200 X,225	D,200,250 D300 X,200,275, 300	
33.0	336				B,450 V,100,150	C,225,275 D,150,175, D,225,250	D,100,150,200	D,90,100 D,225,300 X,175	X,175,250	
47.0	476			B,450 C,250 V,150	D,80,90, 200	C,350 D,100,150, 200	D,100,175 X,65,100 X,125,150	D,120,250 X,150,185, 200	X,185,200, 300	
68.0	686		V,150	D,175	V,100,140 B,600,750 B,900 C,225 D,90,150 X,150	V,180,300 D,150	D,150 X,120,150	X,125,150 200		
100.0	107	T, 3000	B,500	V,90,150 B,400,700 C,150 D,150	V,150 D,65, 80,100 X,100	D,100,125 X,80,100, 125	X,150 E,85,100 200			
150.0	157		B,900 C,250	V,70 C,200 X,100,125	D,80,100 X,85,100 V,100,150	X,75,100				
220.0	227	D,45		C,225 D,45,100 X,50, 60,70, 100	V,150 D,45,75 D,100,125 X, 45,70, 100	E,100,150				
330.0	337		C,300,700 D,30,45	X,35,45,65, X,100 D,40,50,70, D,100 E,40,60,100	D,125 X,50,60 E,60,100					
470.0	477			X,30,45,50, X,65 D,100,125 E,55,100						
680.0	687									
1000.0	108	X,40	X,70 E,35,50	E,50						

Note that standard values are preferred, especially where high surge currents are possible. Extended values are available to increase capacitance and reduce ESR. Note that standard CV values demonstrate inherently lower failure rates than extended CV values, especially in low impedance applications.

Tape & Reel Packaging

KEMET's Molded Tantalum and Aluminum Chip Capacitor families are packaged in 8 mm and 12 mm plastic tape on 7" and 13" reels, in accordance with EIA Standard 481-1: Taping of Surface Mount Components for Automatic Handling. This packaging system is compatible with all tape fed automatic pick and place systems.

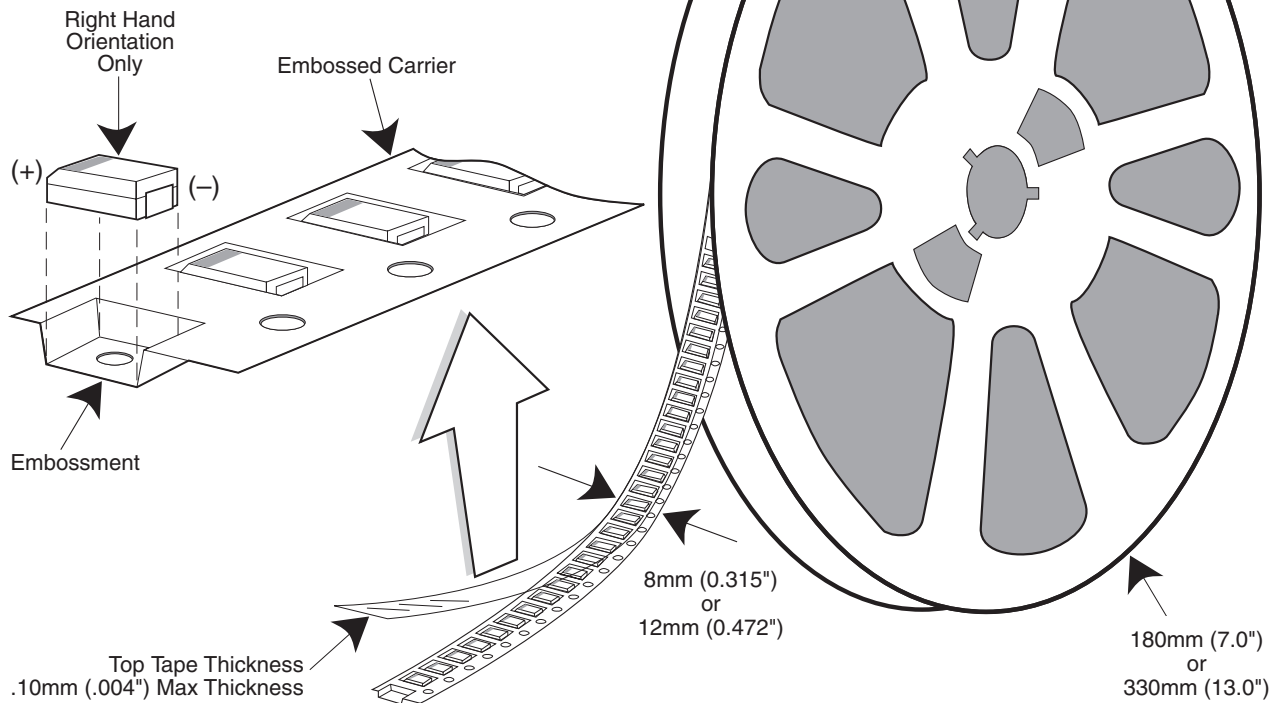

Labeling: Bar code labeling (standard or custom) shall be on the side of the reel opposite the sprocket holes. Refer to EIA-556.

QUANTITIES PACKAGED PER REEL

Case Code		Tape Width-mm	7" Reel*	13" Reel*
KEMET	EIA			
R	2012-12	8	2,500	10,000
S	3216-12	8	2,500	10,000
T	3528-12	8	2,500	10,000
U	6032-15	12	1,000	5,000
W	7343-15	12	1,000	3,000
V	7343-20	12	1,000	3,000
A	3216-18	8	2,000	9,000
B	3528-21	8	2,000	8,000
C	6032-28	12	500	3,000
D	7343-31	12	500	2,500
Y	7343-40	12	500	2,000
X	7343-43	12	500	2,000
E	7260-38	12	500	2,000

* No c-spec required for 7" reel packaging. C-7280 required for 13" reel packaging.

TANTALUM, CERAMIC AND ALUMINUM CHIP CAPACITORS



Packaging Information

Performance Notes

- Cover Tape Break Force:** 1.0 Kg Minimum.
- Cover Tape Peel Strength:** The total peel strength of the cover tape from the carrier tape shall be:

Tape Width	Peel Strength
8 mm	0.1 Newton to 1.0 Newton (10g to 100g)
12 mm	0.1 Newton to 1.3 Newton (10g to 130g)

The direction of the pull shall be opposite the direction of the carrier tape travel. The pull angle of the carrier tape shall be 165° to 180° from the plane of the carrier tape. During peeling, the carrier and/or cover tape shall be pulled at a velocity of 300 ±10 mm/minute.

- Reel Sizes:** Molded tantalum capacitors are available on either 180 mm (7") reels (standard) or 330 mm (13") reels (with C-7280). Note that 13" reels are preferred.
- Labeling:** Bar code labeling (standard or custom) shall be on the side of the reel opposite the sprocket holes. Refer to EIA-556.

Embossed Carrier Tape Configuration: Figure 1

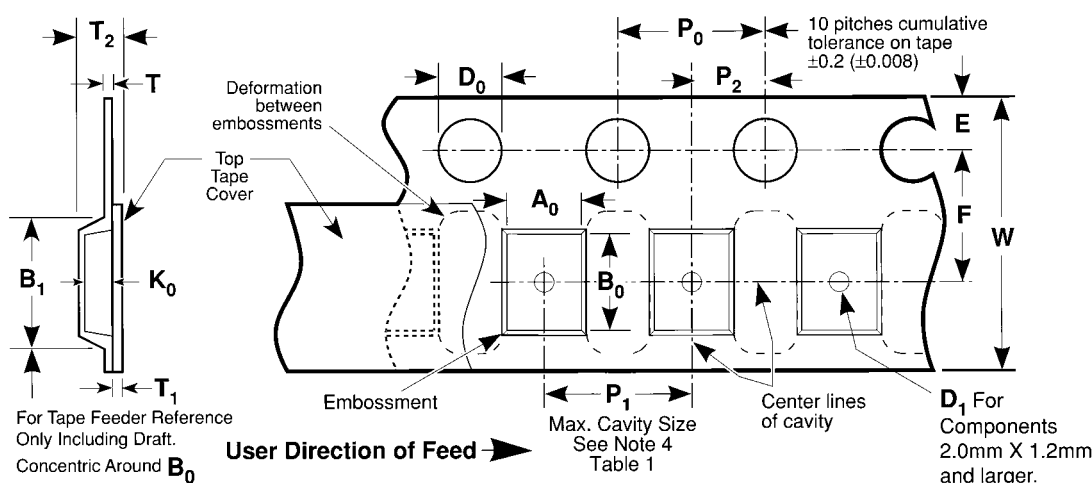

Table 1 — EMBOSSED TAPE DIMENSIONS (Metric will govern)

Constant Dimensions — Millimeters (Inches)									
Tape Size	D ₀	E	P ₀	P ₂	T Max	T ₁ Max			
8 mm and 12 mm	1.5 +0.10 -0.0 (0.059 +0.004, -0.0)	1.75 ±0.10 (0.069 ±0.004)	4.0 ±0.10 (0.157 ±0.004)	2.0 ±0.05 (0.079 ±0.002)	0.600 (0.024)	0.100 (0.004)			
Variable Dimensions — Millimeters (Inches)									
Tape Size	Pitch	B ₁ Max. Note 1	D ₁ Min. Note 2	F	P ₁	R Min. Note 3	T ₂ Max	W	A ₀ B ₀ K ₀ Note 4
8 mm	Single (4 mm)	4.4 (0.173)	1.0 (0.039)	3.5 ±0.05 (0.138 ±0.002)	4.0 ±0.10 (0.157 ±0.004)	25.0 (0.984)	2.5 (0.098)	8.0 ±0.30 (.315 ±0.012)	
12 mm	Double (8 mm)	8.2 (0.323)	1.5 (0.059)	5.5 ±0.05 (0.217 ±0.002)	8.0 ±0.10 (0.315 ±0.004)	30.0 (1.181)	4.6 (0.181)	12.0 ±0.30 (0.472 ±0.012)	

NOTES

- B1 dimension is a reference dimension for tape feeder clearance only.
- The embossment hole location shall be measured from the sprocket hole controlling the location of the embossment. Dimensions of embossment location and hole location shall be applied independent of each other.
- Tape with components shall pass around radius "R" without damage (see sketch A). The minimum trailer length (Fig. 2) may require additional length to provide R min. for 12 mm embossed tape for reels with hub diameters approaching N min. (Table 2)
- The cavity defined by A₀, B₀, and K₀ shall be configured to surround the part with sufficient clearance such that the chip does not protrude beyond the sealing plane of the cover tape, the chip can be removed from the cavity in a vertical direction without mechanical restriction, rotation of the chip is limited to 20 degrees maximum in all 3 planes, and lateral movement of the chip is restricted to 0.5 mm maximum in the pocket (not applicable to vertical clearance.)

TANTALUM, CERAMIC AND ALUMINUM CHIP CAPACITORS

Packaging Information

Embossed Carrier Tape Configuration (cont.)

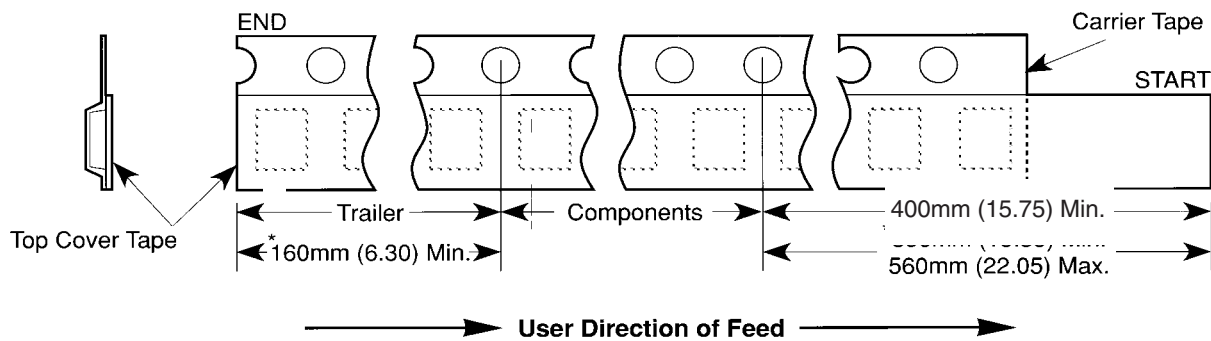
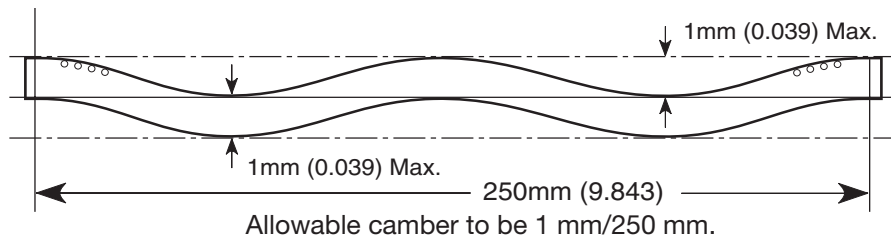
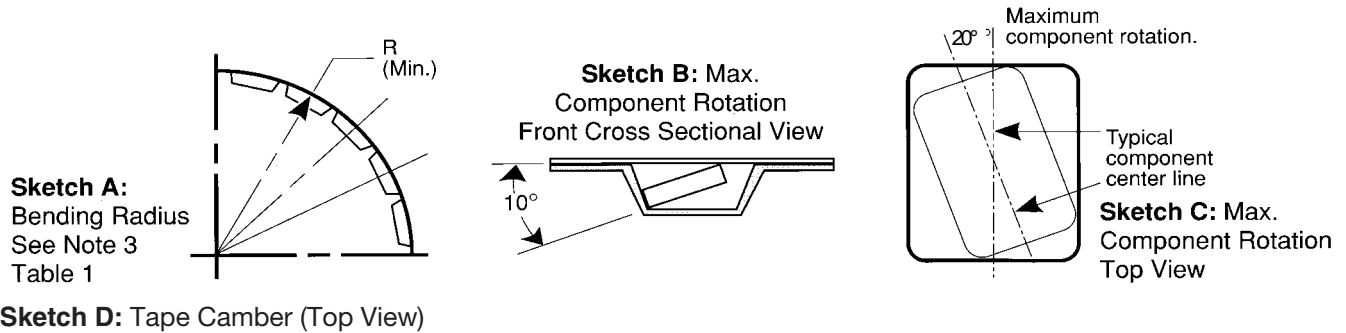

Figure 2:
Tape Leader
& Trailer
Dimensions
(Metric
Dimensions
Will Govern)

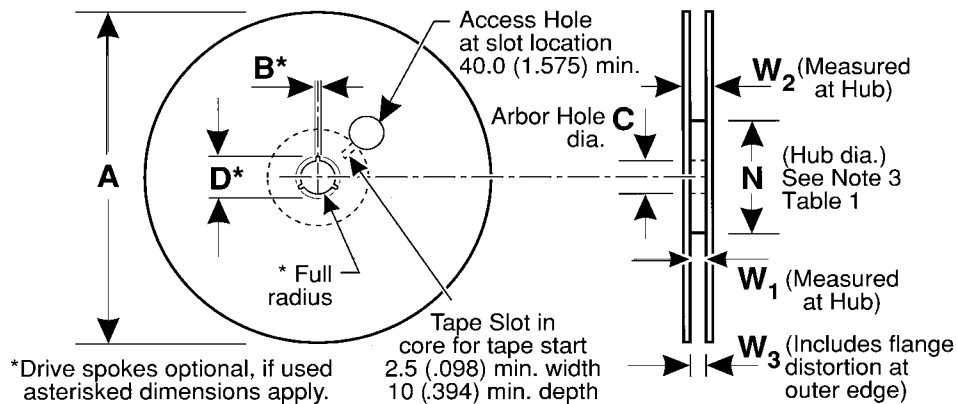

Figure 3: Reel Dimensions (Metric Dimensions will govern)

Table 2 – REEL DIMENSIONS (Metric will govern)

Tape Size	A Max	B* Min	C	D* Min	N Min	W_1	W_2 Max	W_3
8 mm	330.0 (12.992)	1.5 (0.059)	13.0 ± 0.20 (0.512 ± 0.008)	20.2 (0.795)	50.0 (1.969) See Note 3	8.4 +1.5, -0.0 (0.331) +0.059, -0.0)	14.4 (0.567)	7.9 Min (0.311) 10.9 Max (0.429)
12 mm	330.0 (12.992)	1.5 (0.059)	13.0 ± 0.20 (0.512 ± 0.008)	20.2 (0.795)	Table 1	12.4 +2.0, -0.0 (0.488) +0.078, -0.0)	18.4 (0.724)	11.9 Min (0.469) 15.4 Max (0.606)