

**48 V  
Input**

**2.5 V  
Output**

**35 A  
Current**

**2250 V dc  
Isolation**

**Eighth-brick  
DC-DC Converter**

The PQ60025ETL35 PowerQor® Tera Eighth-brick converter is a next-generation, board-mountable, isolated, fixed switching frequency dc-dc converter that uses synchronous rectification to achieve extremely high conversion efficiency. The power dissipated by the converter is so low that a heatsink is not required, which saves cost, weight, height, and application effort. All of the power and control components are mounted to the multi-layer PCB substrate with high-yield surface mount technology. Since the PowerQor converter has no explicit thermal interfaces, it is extremely reliable. RoHS Compliant (see page 13).

**PowerQor®**  
Tera



PQ60025ETL35 Module

#### Operational Features

- High efficiencies, 88% at full rated load current
- Delivers up to 35 A of output current with minimal derating - no heatsink required
- Wide input voltage range: 35V – 75 V, with 100 V 100 ms input voltage transient capability
- Fixed frequency switching provides predictable EMI performance
- No minimum load requirement means no preload resistors required

#### Mechanical Features

- Industry standard Eighth-brick pin-out configuration
- Standard size: 0.90" x 2.3" (22.9x58.4 mm)
- Total height only 0.320" (8.13mm), permits better airflow and smaller card pitch
- Total weight: 0.85 oz (24 g)
- Flanged pins designed to permit surface mount soldering (avoid wave solder) using FPIP technique

#### Control Features

- On/Off control referenced to input side (positive and negative logic options are available)
- Remote sense for the output voltage compensates for output distribution drops
- Output voltage trim permits custom voltages and voltage margining

#### Protection Features

- Input under-voltage lockout disables converter at low input voltage conditions
- Output current limit and short circuit protection protects converter and load from permanent damage and consequent hazardous conditions
- Active back bias limit prevents damage to converter from external load induced pre-bias
- Output over-voltage protection protects load from damaging voltages
- Thermal shutdown protects converter from abnormal environmental conditions

#### Safety Features

- 2250 V, 30 MΩ input-to-output isolation
- UL 60950-1 recognized (US & Canada), basic insulation rating
- TUV certified to EN60950-1
- Meets 72/23/EEC and 93/68/EEC directives which facilitates CE Marking in user's end product
- Board and plastic components meet UL94V-0 standard
- RoHS compliant (see last page)

## MECHANICAL DIAGRAM

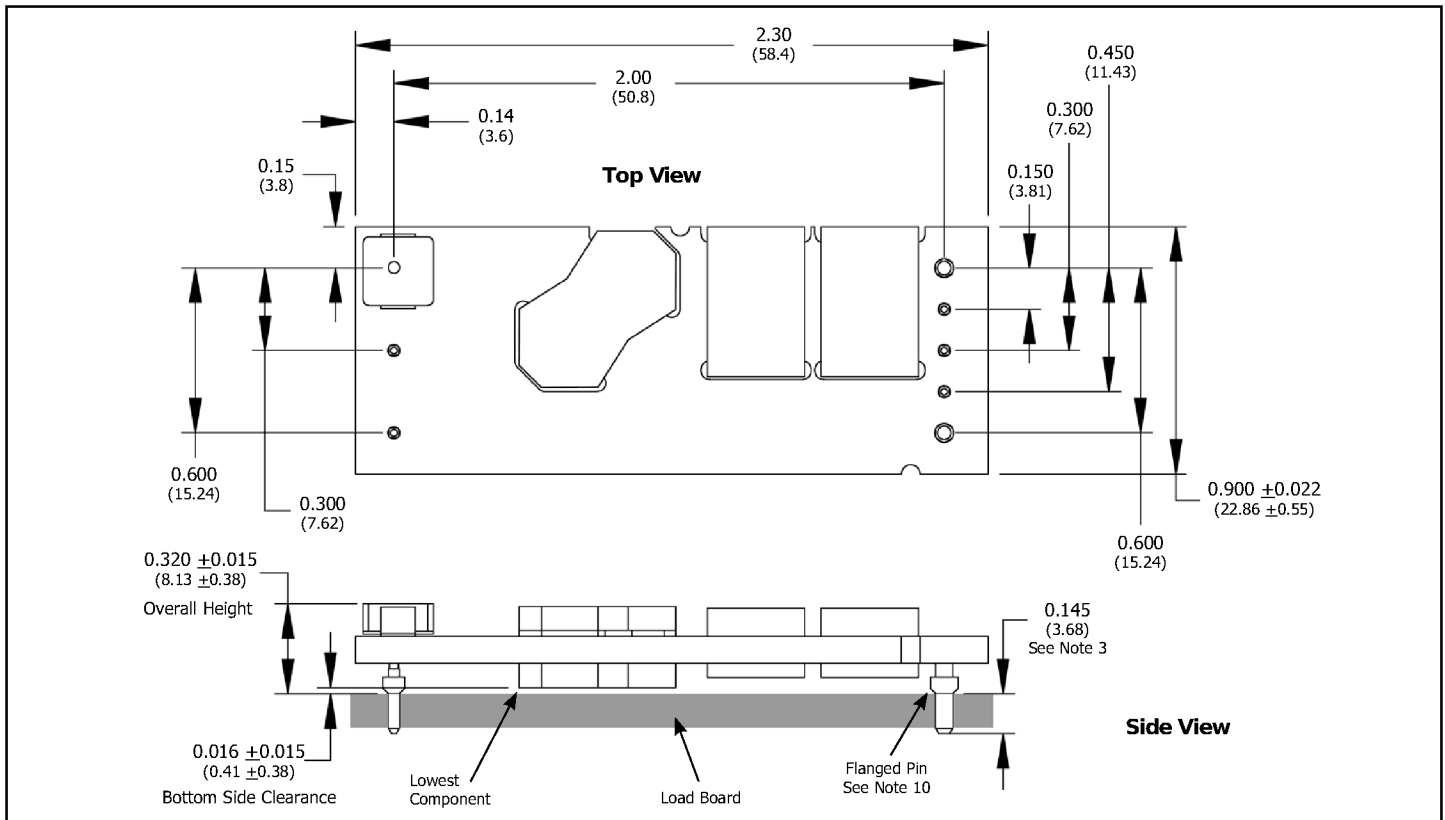

## NOTES

- 1) Pins 1-3, 5-7 are 0.040" (1.02mm) diameter with 0.080" (2.03 mm) diameter standoff shoulders.
- 2) Pins 4 and 8 are 0.062" (1.57 mm) diameter with 0.100" (2.54 mm) diameter standoff shoulders.
- 3) Recommended pin length is 0.03" (0.76mm) greater than the PCB thickness. Other pin lengths available.
- 4) All Pins: Material - Copper Alloy; Finish - Matte Tin over Nickel plate
- 5) Undimensioned components shown are for visual reference only.
- 6) Weight: 0.85 oz. (24 g) typical
- 7) All dimensions in inches (mm)  
Tolerances: x.xx +/-0.02 in. (x.x +/-0.5mm)  
x.xxx +/-0.010 in. (x.xxx +/-0.25mm)
- 8) Workmanship: Meets or exceeds current IPC-A-610C Class II
- 9) UL/TUV standards require a clearance greater than 0.04" (1.02mm) between input and output for Basic insulation. This issue should be considered if any copper traces are on the top side of the user's board. Note that the ferrite core shown at left above is considered part of the input/primary circuit and that the two ferrite cores shown at the right above are considered part of the output/secondary circuit.
- 10) The flanged pins are designed to permit surface mount soldering (allowing to avoid the wave soldering process) through the use of the flanged pin-in-paste technique.

## PIN DESIGNATIONS

Pin No.	Name	Function
1	Vin (+)	Positive input voltage
2	ON/OFF	TTL input to turn converter on and off, referenced to Vin (-) with internal pull up
3	Vin (-)	Negative input voltage
4	Vout (-)	Negative output voltage
5	SENSE (-)	Negative remote sense <sup>1</sup>
6	TRIM	Output voltage trim <sup>2</sup>
7	SENSE (+)	Positive remote sense <sup>3</sup>
8	Vout (+)	Positive output voltage

### Notes:

1. SENSE(-) should be connected to Vout(-) either remotely or at the converter.
2. Leave TRIM pin open for nominal output voltage.
3. SENSE(+) should be connected to Vout(+) either remotely or at the converter.

## PQ60025ETL35 Electrical Characteristics

$T_A = 25\text{ }^\circ\text{C}$ , airflow rate = 300 LFM,  $V_{IN} = 48\text{ V}_{DC}$  unless otherwise noted; full operating temperature range is  $-40\text{ }^\circ\text{C}$  to  $+100\text{ }^\circ\text{C}$  ambient temperature with appropriate power derating. Specifications subject to change without notice.

Parameter	Min.	Typ.	Max.	Units	Notes & Conditions
<b>ABSOLUTE MAXIMUM RATINGS</b>					
Input Voltage					
Non-Operating			100	V	Continuous
Operating	35		75	V	Continuous
Operating Transient Protection			100	V	100 ms transient, square wave
Isolation Voltage					Basic Insulation, Pollution Degree 2
Input to Output			2250	Vdc	
Operating Temperature	-40		100	$^\circ\text{C}$	
Storage Temperature	-55		125	$^\circ\text{C}$	
Voltage at ON/OFF input pin	-2		18	V	
<b>INPUT CHARACTERISTICS</b>					
Operating Input Voltage Range	35	48	75	V	
Input Under-Voltage Lockout					
Turn-On Voltage Threshold	31.5	32.6	33.7	V	
Turn-Off Voltage Threshold	29.6	30.6	31.6	V	
Lockout Voltage Hysteresis	1.9	2.0	2.1	V	
Maximum Input Current			3.0	A	100% Load, 35 Vin, nominal Vout
No-Load Input Current	0	46	75	mA	
Disabled Input Current		6	10	mA	
Inrush Current Transient Rating			0.01	A's	
Response to Input Transient		7.5		mV	1000V/ms input transient
Input Reflected Ripple Current		1.9		mA	RMS thru 10 $\mu\text{H}$ inductor; Figures 13 & 15
Input Terminal Ripple Current		75		mA	RMS; Figures 13 & 14
Recommended Input Fuse			20	A	Fast blow external fuse recommended
Input Filter Component Values (L\C)			1.0 \ 3.3	$\mu\text{H}\mu\text{F}$	Internal values; see Figure E
Recommended External Input Capacitance		47		$\mu\text{F}$	Typical ESR 0.1-0.2 $\Omega$ ; see Figure 13
<b>OUTPUT CHARACTERISTICS</b>					
Output Voltage Set Point	2.475	2.500	2.525	V	
Output Voltage Regulation					
Over Line		$\pm 0.1 \setminus 2.5$		%\mV	
Over Load		$\pm 0.2 \setminus 5.0$		%\mV	
Over Temperature		$\pm 15$	$\pm 38$	mV	
Total Output Voltage Range	2.43	2.500	2.57	V	Over sample, line, load, temperature & life
Output Voltage Ripple and Noise <sup>1</sup>					20MHz bandwidth; Figures 13 & 16
Peak-to-Peak		20	50	mV	Full Load; see Figures 13 & 16
RMS		7	50	mV	Full Load; see Figures 13 & 16
Operating Output Current Range	0		35	A	Subject to thermal derating; Figures 5 - 8
Output DC Current-Limit Inception	40	44	48	A	Output Voltage 10% Low
Output DC Current-Limit Shutdown Voltage		1.5		V	
Back-Drive Current Limit while Enabled		12		A	Negative current drawn from output
Back-Drive Current Limit while Disabled		10	50	mA	Negative current drawn from output
Maximum Output Capacitance Electrolytic			33	mF	2.5Vout at 35A Resistive Load
Minimum Output Capacitance					Not applicable
Maximum Output Capacitance Ceramic		5		mF	2.5Vout at 35A Resistive Load
<b>DYNAMIC CHARACTERISTICS</b>					
Input Voltage Ripple Rejection		70		dB	120 Hz; Figure 20
Output Voltage during Load Current Transient					
For a Step Change in Output Current (0.1A/ $\mu\text{s}$ )		100		mV	50% to 75% to 50% Iout max; Figure 11
For a Step Change in Output Current (0.3A/ $\mu\text{s}$ )		100		mV	50% to 75% to 50% Iout max; Figure 12
Settling Time		80		$\mu\text{s}$	To within 1% Vout nom
Turn-On Transient					
Turn-On Time	6	9	12	ms	Full load, Vout=90% nom.; Figures 9 & 10
Start-Up Inhibit Time	9	12	17	ms	-40 $^\circ\text{C}$ to +125 $^\circ\text{C}$ ; Figure F
Restart Inhibit Time	190	200	210	ms	-40 $^\circ\text{C}$ to +125 $^\circ\text{C}$ ; Figure F
Output Voltage Overshoot		0		%	No load capacitance, Iout = 0A
<b>EFFICIENCY</b>					
100% Load		88		%	Figures 1 - 4
50% Load		90		%	Figures 1 - 4
<b>TEMPERATURE LIMITS FOR POWER DERATING CURVES</b>					
Semiconductor Junction Temperature			125	$^\circ\text{C}$	Package rated to 150 $^\circ\text{C}$
Board Temperature			125	$^\circ\text{C}$	UL rated max operating temp 130 $^\circ\text{C}$
Transformer Temperature			125	$^\circ\text{C}$	See Figures 5 - 8 for derating curves

**Note 1:** Output voltage ripple can exceed maximum specification during startup when output voltage is less than 1.2V. Additional output capacitance will mitigate this startup ripple behavior. For applications requiring reduced output voltage ripple and noise, consult SynQor applications support (e-mail: support@synqor.com)

**Note 2:** Higher values of isolation capacitance can be added external to the module.

## PQ60025ETL35 ELECTRICAL CHARACTERISTICS (Continued)

$T_A = 25\text{ }^\circ\text{C}$ , airflow rate = 300 LFM,  $V_{IN} = 48\text{ V}_{DC}$  unless otherwise noted; full operating temperature range is  $-40\text{ }^\circ\text{C}$  to  $+100\text{ }^\circ\text{C}$  ambient temperature with appropriate power derating. Specifications subject to change without notice.

Parameter	Min.	Typ.	Max.	Units	Notes & Conditions
<b>ISOLATION CHARACTERISTICS</b>					
Isolation Voltage (dielectric strength)		2250		V	
Isolation Resistance		30		MΩ	
Isolation Capacitance <sup>2</sup>		3300		pF	
<b>FEATURE CHARACTERISTICS</b>					
Switching Frequency	317	333	350	kHz	
ON/OFF Control (Option P)					
Off-State Voltage	-2		0.8	V	
On-State Voltage	2.4		18	V	
ON/OFF Control (Option N)					
Off-State Voltage	2.4		18	V	
On-State Voltage	-2		0.8	V	
ON/OFF Control (Either Option)					Figures A & B
Pull-Up Voltage			5	V	
Pull-Up Resistance		10		kΩ	
Output Voltage Trim Range	-20		+10	%	Measured across Pins 8 & 4; Figure C
Output Voltage Remote Sense Range			+10	%	Measured across Pins 8 & 4
Output Over-Voltage Protection	120	148	160	%	Over full temp range; % of nominal Vout
Over-Temperature Shutdown		120		$^\circ\text{C}$	Average PCB Temperature
Over-Temperature Shutdown Restart Hysteresis		10		$^\circ\text{C}$	
<b>RELIABILITY CHARACTERISTICS</b>					
Calculated MTBF (Telcordia) TR-NWT-000332		2.42		10 <sup>6</sup> Hrs.	80% load, 300LFM, 40 $^\circ\text{C}$ T <sub>a</sub>
Calculated MTBF (MIL-217) MIL-HDBK-217F		2.27		10 <sup>6</sup> Hrs.	80% load, 300LFM, 40 $^\circ\text{C}$ T <sub>a</sub>
Field Demonstrated MTBF				10 <sup>6</sup> Hrs.	See our website for latest values

**Note 1:** Output voltage ripple can exceed maximum specification during startup when output voltage is less than 1.2V. Additional output capacitance will mitigate this startup ripple behavior. For applications requiring reduced output voltage ripple and noise, consult SynQor applications support (e-mail: support@synqor.com)

**Note 2:** Higher values of isolation capacitance can be added external to the module.

## STANDARDS COMPLIANCE

Parameter	Notes
<b>STANDARDS COMPLIANCE</b>	
UL/cUL 60950-1	File # E194341, Basic insulation, Pollution Degree 2
EN60950-1	Certified by TÜV
72/23/EEC	
93/68/EEC	
Needle Flame Test (IEC 695-2-2)	Test on entire assembly; board & plastic components UL94V-0 compliant
IEC 61000-4-2	ESD test, 8 kV - NP, 15 kV air - NP (Normal Performance)
GR-1089-CORE	Section 7 - electrical safety, Section 9 - bonding/grounding
Telcordia (Bellcore) GR-513	

- An external input fuse must always be used to meet these safety requirements. Contact SynQor for official safety certificates on new releases or download from the SynQor website.

## QUALIFICATION TESTING

Parameter	# Units	Test Conditions
<b>QUALIFICATION TESTING</b>		
Life Test	32	95% rated Vin and load, units at derating point, 1000 hours
Vibration	5	10-55 Hz sweep, 0.060" total excursion, 1 min./sweep, 120 sweeps for 3 axis
Mechanical Shock	5	100 g minimum, 2 drops in x and y axis, 1 drop in z axis
Temperature Cycling	10	-40 $^\circ\text{C}$ to 100 $^\circ\text{C}$ , unit temp. ramp 15 $^\circ\text{C}/\text{min.}$ , 500 cycles
Power/Thermal Cycling	5	Toperating = min to max, Vin = min to max, full load, 100 cycles
Design Marginality	5	Tmin-10 $^\circ\text{C}$ to Tmax+10 $^\circ\text{C}$ , 5 $^\circ\text{C}$ steps, Vin = min to max, 0-105% load
Humidity	5	85 $^\circ\text{C}$ , 85% RH, 1000 hours, 2 minutes on and 6 hours off
Solderability	15 pins	MIL-STD-883, method 2003

- Extensive characterization testing of all SynQor products and manufacturing processes is performed to ensure that we supply robust, reliable product. Contact the factory for official product family qualification documents.

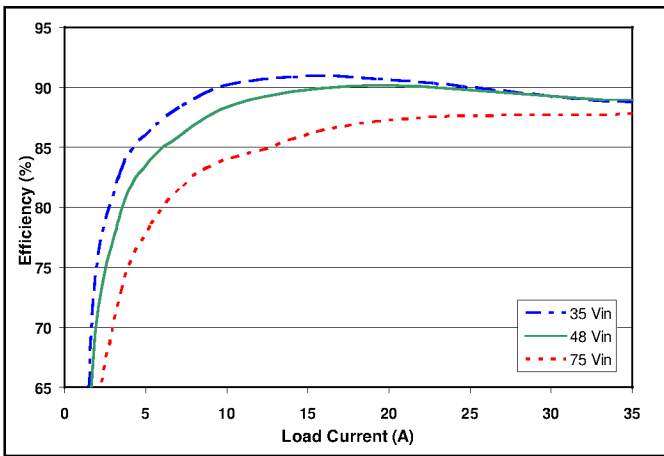

**Figure 1:** Efficiency at nominal output voltage vs. load current for minimum, nominal, and maximum input voltage at 25°C.

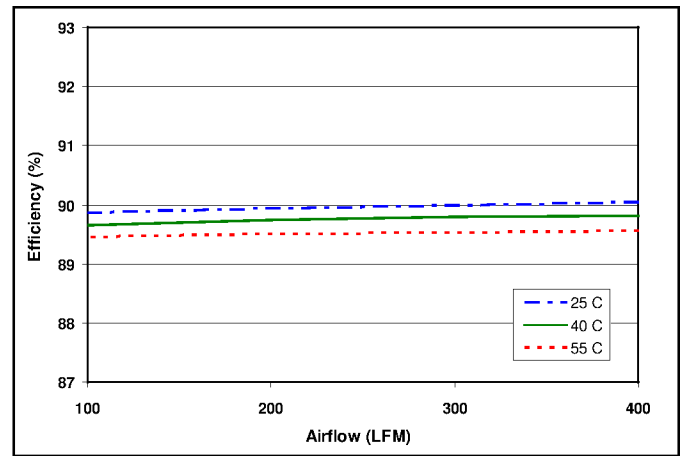

**Figure 2:** Efficiency at nominal output voltage and 60% rated power vs. airflow rate for ambient air temperatures of 25°C, 40°C, and 55°C (nominal input voltage).

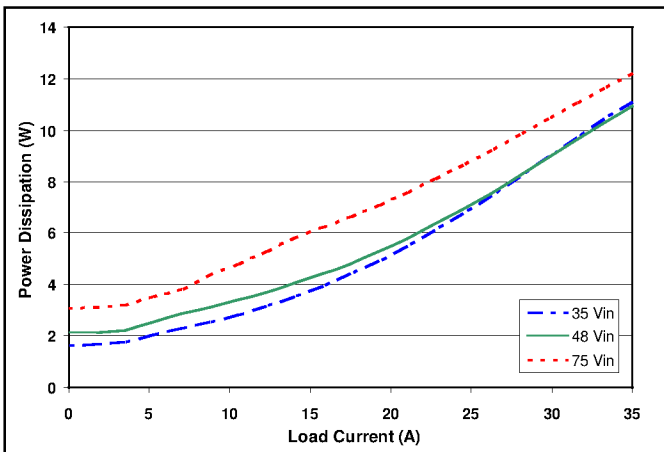

**Figure 3:** Power dissipation at nominal output voltage vs. load current for minimum, nominal, and maximum input voltage at 25°C.

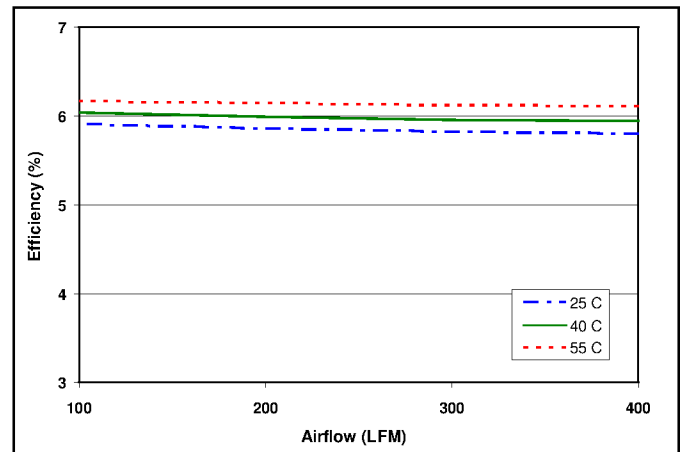

**Figure 4:** Power dissipation at nominal output voltage and 60% rated power vs. airflow rate for ambient air temperatures of 25°C, 40°C, and 55°C (nominal input voltage).

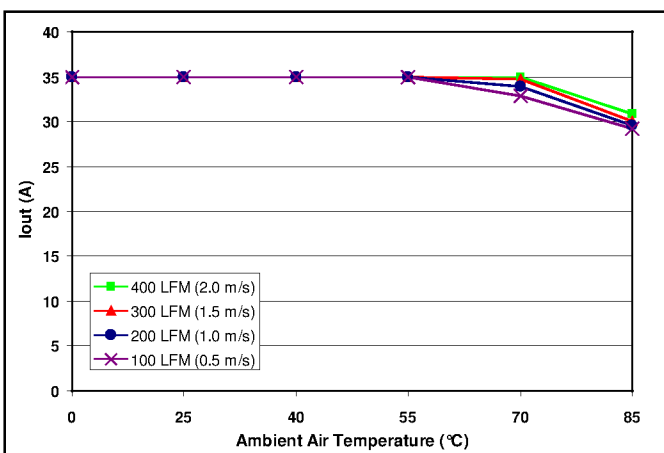

**Figure 5:** Maximum output power-derating curves vs. ambient air temperature for airflow rates of 100 LFM through 400 LFM with air flowing from pin 3 to pin 1 (nominal input voltage).

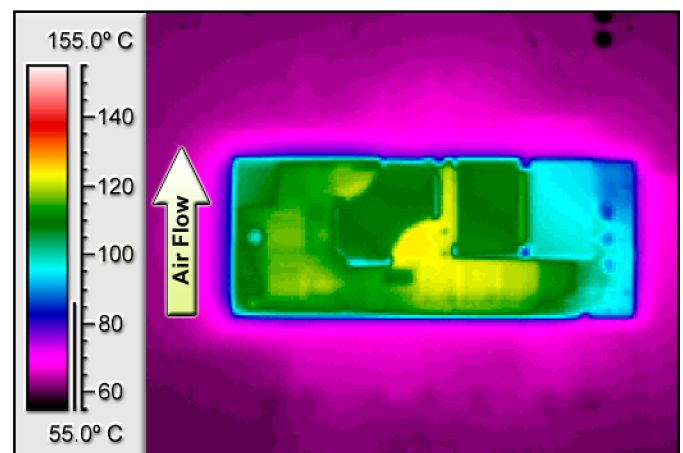

**Figure 6:** Thermal plot of converter at 35 amp load current (87.5W) with 55°C air flowing at the rate of 200 LFM. Air is flowing across the converter from 3 to pin 1 (nominal input voltage).

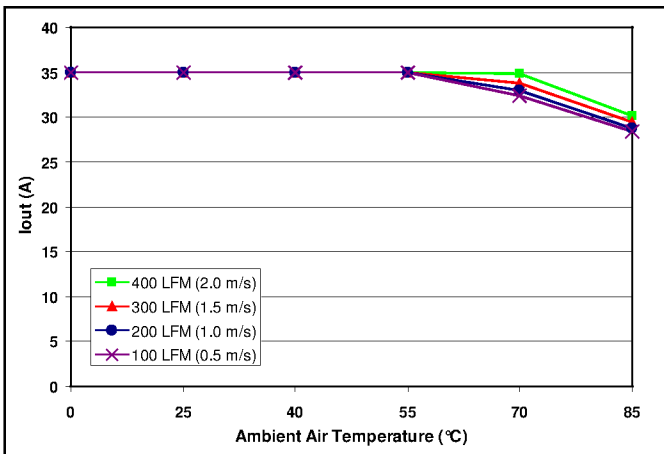

**Figure 7:** Maximum output power derating curves vs. ambient air temperature for airflow rates of 100 LFM through 400 LFM with air flowing across the converter from pin input to output (nominal input voltage).

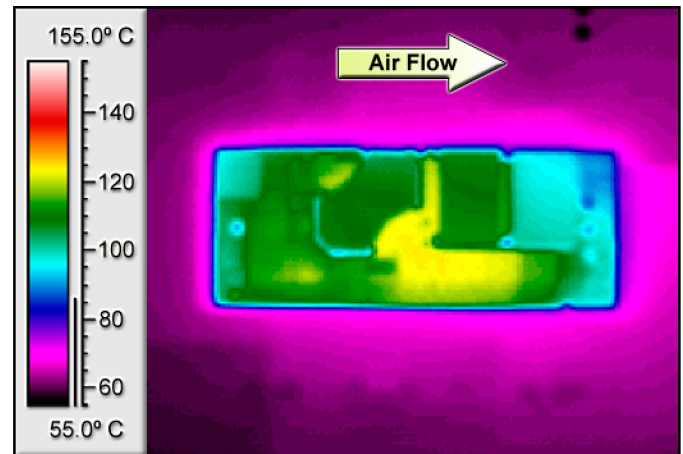

**Figure 8:** Thermal plot of converter at 35 amp load current (87.5W) with 55°C air flowing at the rate of 200 LFM. Air is flowing across the converter from input to output (nominal input voltage).

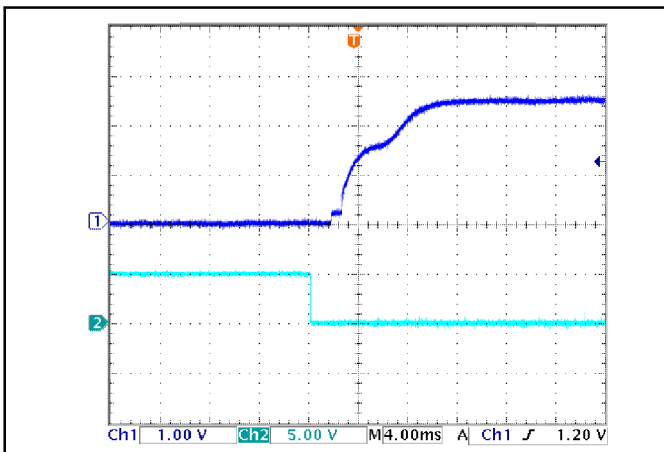

**Figure 9:** Turn-on transient at full load (resistive load) (4 ms/div). Load cap: 10uF, 100 mΩ ESR tantalum capacitor and 1uF ceramic capacitor. Input voltage pre-applied. Ch 1: V<sub>out</sub> (1V/div), Ch 2: ON/OFF input (5V/div).

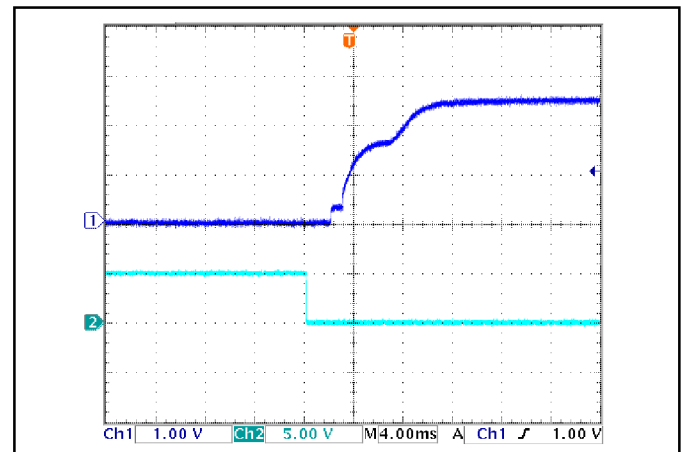

**Figure 10:** Turn-on transient at zero load (4 ms/div). Load cap: 10uF, 100 mΩ ESR tantalum capacitor and 1uF ceramic capacitor. Ch 1: V<sub>out</sub> (1V/div), Ch 2: ON/OFF input (5V/div).

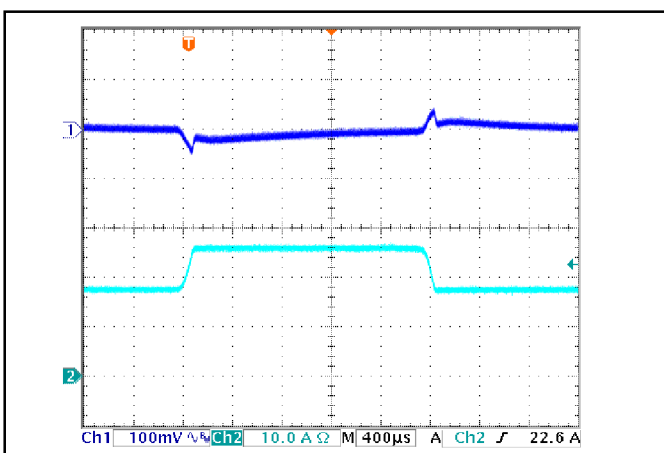

**Figure 11:** Output voltage response to step-change in load current (50%-75%-50% of I<sub>out</sub>(max); di/dt = 0.1A/μs). Load cap: 10uF, 100 mΩ ESR tantalum cap and 1uF ceramic cap. Ch 1: V<sub>out</sub> (100mV/div), Ch 2: I<sub>out</sub> (10A/div).

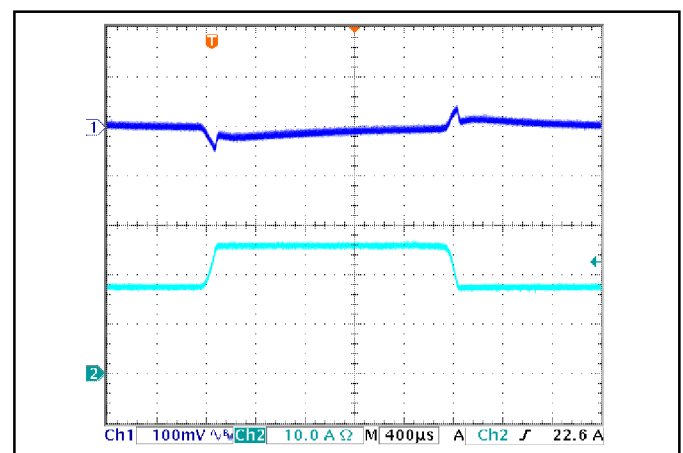

**Figure 12:** Output voltage response to step-change in load current (50%-75%-50% of I<sub>out</sub>(max); di/dt = 0.3 A/μs). Load cap: 10uF, 100 mΩ ESR tantalum cap and 1uF ceramic cap. Ch 1: V<sub>out</sub> (100mV/div), Ch 2: I<sub>out</sub> (10A/div).

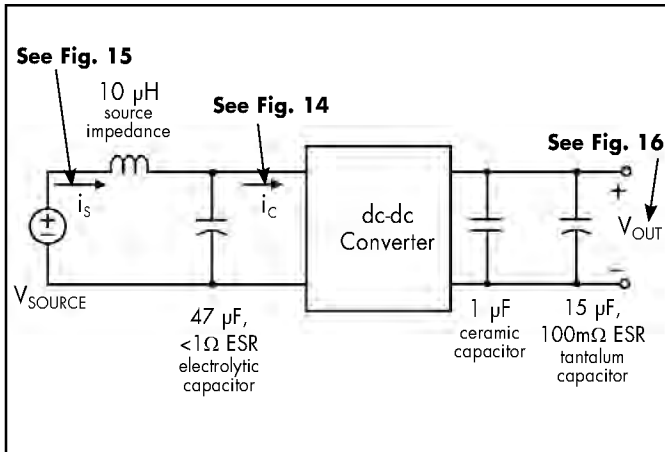

**Figure 13:** Test set-up diagram showing measurement points for Input Terminal Ripple Current (Figure 14), Input Reflected Ripple Current (Figure 15) and Output Voltage Ripple (Figure 16).

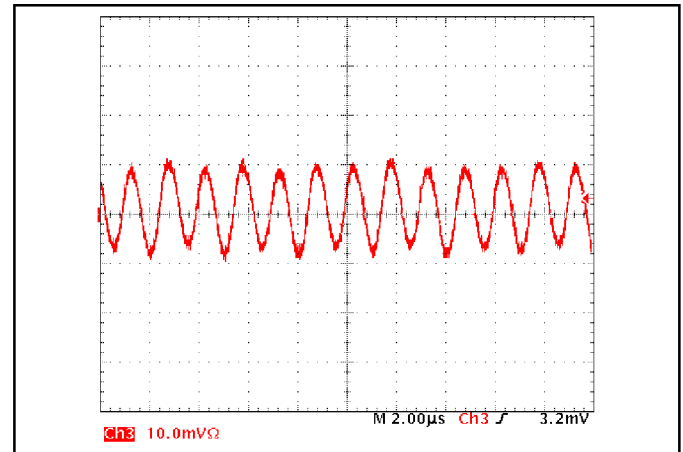

**Figure 14:** Input Terminal Ripple Current,  $i_c$ , at full rated output current and nominal input voltage with  $10\ \mu\text{H}$  source impedance and  $47\ \mu\text{F}$  electrolytic capacitor ( $100\ \text{mA}/\text{div}$ ). Bandwidth:  $250\text{MHz}$ . See Figure 13.

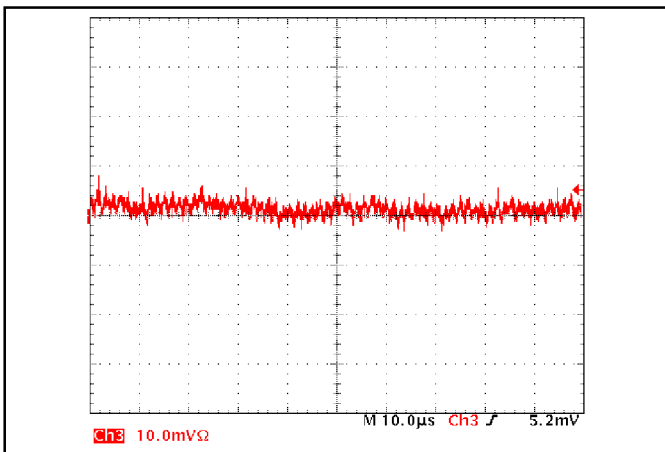

**Figure 15:** Input reflected ripple current,  $i_s$ , through a  $10\ \mu\text{H}$  source inductor, using a  $47\ \mu\text{F}$  electrolytic input capacitor ( $2\text{mA}/\text{div}$ ). Bandwidth:  $250\text{MHz}$ . See Figure 13.

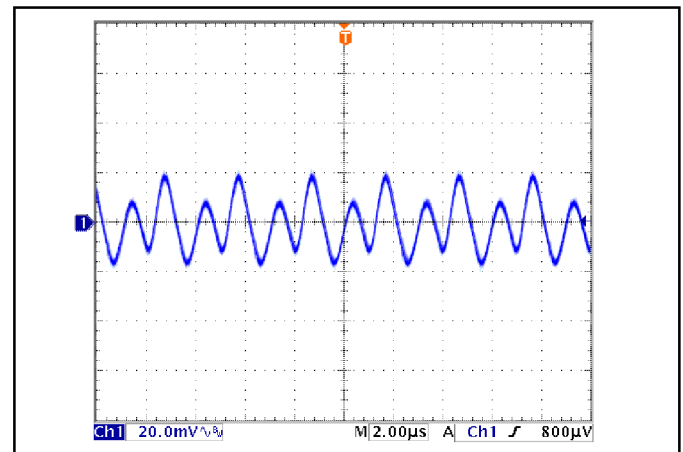

**Figure 16:** Output voltage ripple at nominal input voltage and rated load current ( $20\ \text{mV}/\text{div}$ ). Load capacitance:  $1\ \mu\text{F}$  ceramic capacitor and  $15\ \mu\text{F}$  tantalum capacitor. Bandwidth:  $20\ \text{MHz}$ . See Figure 13.

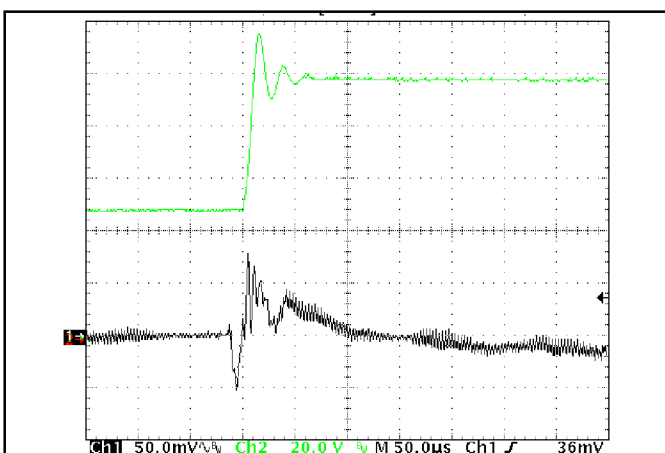

**Figure 17:** Output voltage response to step-change in input voltage ( $50\ \text{V}$  to  $100\ \text{V}$  in  $8\ \mu\text{s}$ ), at  $17.5\ \text{A}$  load current. Load cap:  $15\ \mu\text{F}$   $100\text{m}\Omega$  ESR tantalum capacitor and  $1\ \mu\text{F}$  ceramic cap. Ch 1:  $V_{out}$  ( $50\text{mV}/\text{div}$ ), Ch 2:  $V_{in}$  ( $20\text{V}/\text{div}$ ).

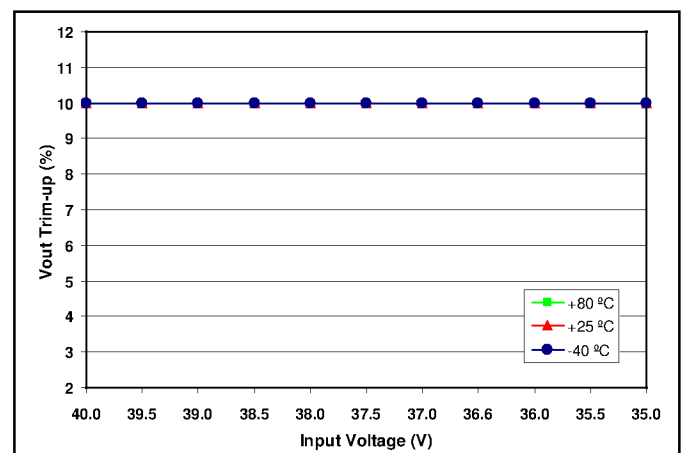

**Figure 18:** Maximum trim up vs. input voltage at different temperatures  $V_{in}=35.0\sim 40.0\ \text{V}$ .

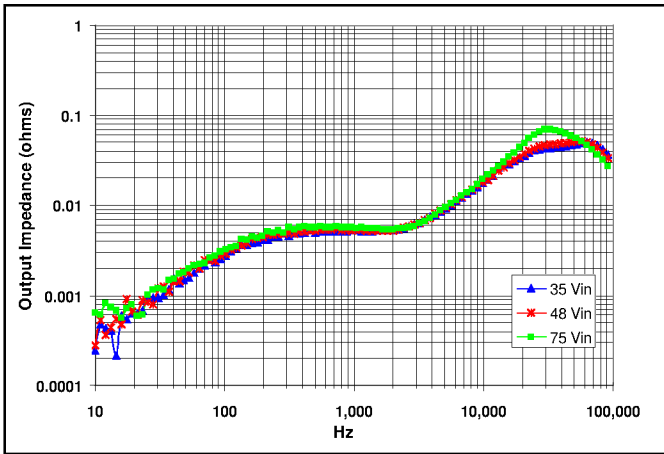

Figure 19: Magnitude of incremental output impedance ( $Z_{out} = V_{out}/I_{out}$ ) for minimum, nominal, and maximum input voltage at full rated power.

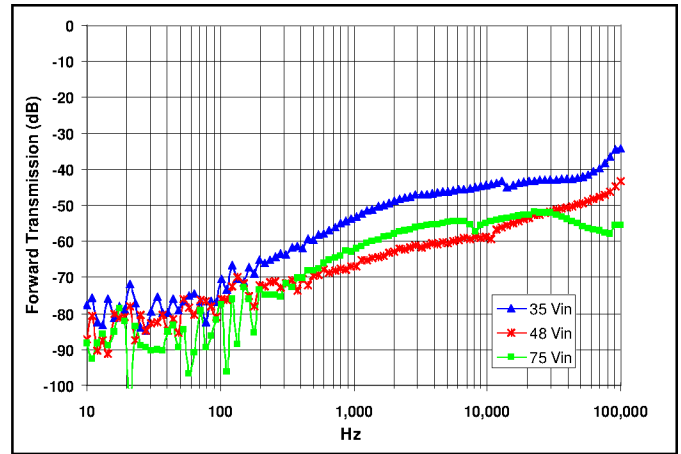

Figure 20: Magnitude of incremental forward transmission ( $FT = V_{out}/V_{in}$ ) for minimum, nominal, and maximum input voltage at full rated power.

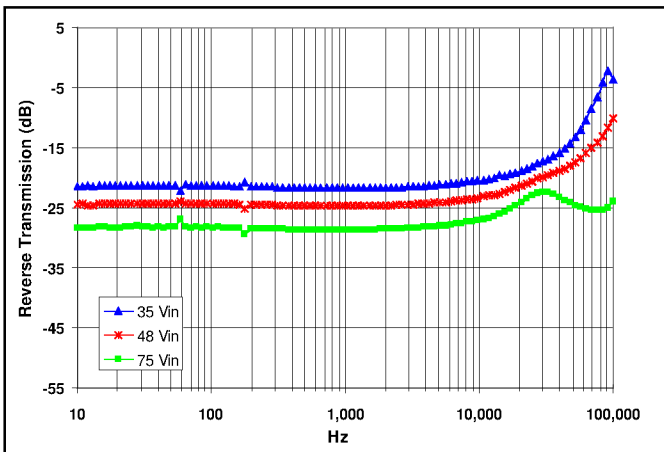

Figure 21: Magnitude of incremental reverse transmission ( $RT = I_{in}/I_{out}$ ) for minimum, nominal, and maximum input voltage at full rated power.

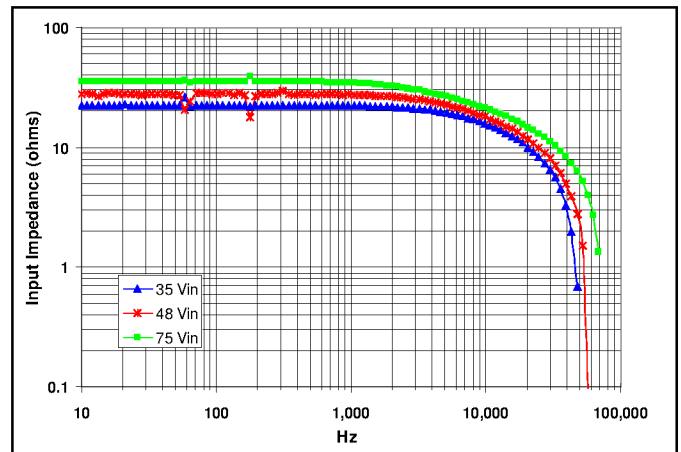

Figure 22: Magnitude of incremental input impedance ( $Z_{in} = V_{in}/I_{in}$ ) for minimum, nominal, and maximum input voltage at full rated power.

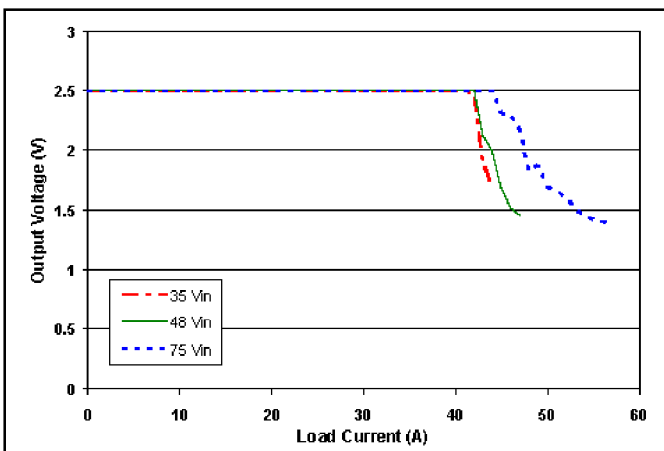

Figure 23: Output voltage vs. load current showing typical current limit curves and converter shutdown points.



### BASIC OPERATION AND FEATURES

The single stage power converter switches at a fixed frequency for predictable EMI performance. Rectification of the transformer's output is accomplished with synchronous rectifiers. These devices, which are MOSFETs with a very low on-state resistance, dissipate far less energy than Schottky diodes. This is the primary reason that the PowerQor converter has such high efficiency, even at very low output voltages and very high output currents.

Dissipation throughout the converter is so low that it does not require a heatsink for operation. Since a heatsink is not required, the PowerQor converter does not need a metal baseplate or potting material to help conduct the dissipated energy to the heatsink. The PowerQor converter can thus be built more simply and reliably using high yield surface mount techniques on a PCB substrate.

The PowerQor series of eighth-brick, quarter-brick and half-brick converters uses the industry standard footprint and pin-out configuration.

### CONTROL FEATURES

**REMOTE ON/ OFF (Pin 2):** The ON/OFF input, Pin 2, permits the user to control when the converter is on or off. This input is referenced to the return terminal of the input bus, Vin(-). There are two versions of the converter that differ by the sense of the logic used for the ON/OFF input.

In the positive logic version, the ON/OFF input is active high (meaning that a high turns the converter on). In the negative logic version, the ON/OFF signal is active low (meaning that a low turns the converter on). Figure A details five possible circuits for driving the ON/OFF pin. Figure B is a detailed look of the internal ON/OFF circuitry.

**REMOTE SENSE(±) (Pins 7 and 5):** The SENSE(±) inputs correct for voltage drops along the conductors that connect the converter's output pins to the load.

Pin 7 should be connected to Vout(+) and Pin 5 should be connected to Vout(-) at the point on the board where regulation is desired. A remote connection at the load can adjust for a voltage drop only as large as that specified in this datasheet, that is

$$[V_{out(+)} - V_{out(-)}] - [V_{sense(+)} - V_{sense(-)}] \leq \text{Sense Range \%} \times V_{out}$$

Pins 7 and 5 must be connected for proper regulation of the output voltage. If these connections are not made, the converter will deliver an output voltage that is slightly higher than its specified value.

**Note:** the output over-voltage protection circuit senses the voltage across the output (pins 8 and 4) to determine when it should trigger, not the voltage across the converter's sense leads (pins 7 and 5). Therefore, the resistive drop on the board should be small enough so that output OVP does not trigger, even during load transients.

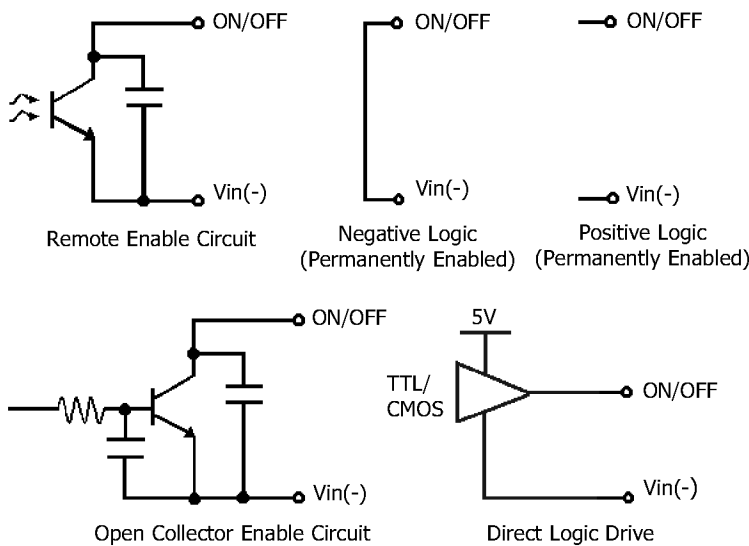

Figure A: Various circuits for driving the ON/OFF pin.

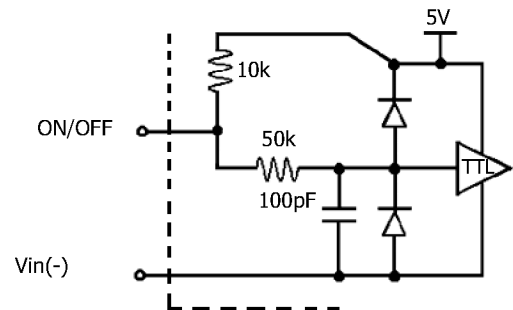

Figure B: Internal ON/OFF pin circuitry

**OUTPUT VOLTAGE TRIM (Pin 6):** The TRIM input permits the user to adjust the output voltage across the sense leads up or down according to the trim range specifications.

To decrease the output voltage, the user should connect a resistor between Pin 6 and Pin 5 (SENSE(-) input). For a desired decrease of the nominal output voltage, the value of the resistor should be

$$R_{\text{trim-down}} = \left( \frac{511}{\Delta\%} \right) - 10.22 \text{ (k}\Omega\text{)}$$

where

$$\Delta\% = \left| \frac{V_{\text{nominal}} - V_{\text{desired}}}{V_{\text{nominal}}} \right| \times 100\%$$

To increase the output voltage, the user should connect a resistor between Pin 6 and Pin 7 (SENSE(+) input). For a desired increase of the nominal output voltage, the value of the resistor should be

$$R_{\text{trim-up}} = \left( \frac{5.11V_{\text{OUT}}(100+\Delta\%)}{1.225\Delta\%} - \frac{511}{\Delta\%} - 10.22 \right) \text{ (k}\Omega\text{)}$$

where

$$V_{\text{OUT}} = \text{Nominal Output Voltage}$$

Figure C graphs the relationship between the trim resistor value and Rtrim-up and Rtrim-down, showing the total range the output voltage can be trimmed up or down.

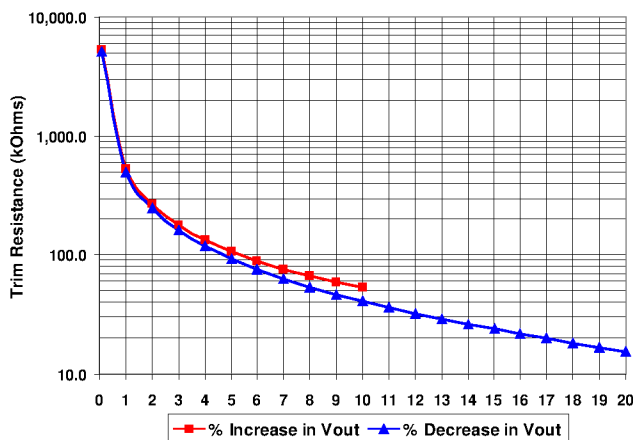

Figure C: Trim Graph for 2.5Vout module

**Note:** the TRIM feature does not affect the voltage at which the output over-voltage protection circuit is triggered. Trimming the output voltage too high may cause the over-voltage protection circuit to engage, particularly during transients. It is not necessary for the user to add capacitance at the Trim pin. The node is internally bypassed to eliminate noise.

**Total DC Variation of Vout:** For the converter to meet its full specifications, the maximum variation of the DC value of Vout, due to both trimming and remote load voltage drops, should not be greater than that specified for the output voltage trim range.

## PROTECTION FEATURES

**Input Under-Voltage Lockout:** The converter is designed to turn off when the input voltage is too low, helping avoid an input system instability problem, described in more detail in the application note titled "Input System Instability". The lockout circuitry is a comparator with DC hysteresis. When the input voltage is rising, it must exceed the typical Turn-On Voltage Threshold value (listed on the specification page) before the converter will turn on. Once the converter is on, the input voltage must fall below the typical Turn-Off Voltage Threshold value before the converter will turn off.

**Output Current Limit:** Once the output current reaches the current-limit inception point, the converter will decrease the output voltage as the output current increases. However, once the impedance of the short across the output is small enough to make the output voltage drop below the specified Output DC Current-Limit Shutdown Voltage, the converter turns off (see Figure 23).

The converter then enters a "hiccup mode" where it repeatedly turns on and off at a 5 Hz (nominal) frequency with a 5% duty cycle until the short circuit condition is removed. This prevents excessive heating of the converter or the load board.

**Output Over-Voltage Limit:** If the voltage across the output pins exceeds the Output Over-Voltage Protection threshold, the converter will immediately stop switching. This prevents damage to the load circuit due to 1) excessive series resistance in output current path from converter output pins to sense point, 2) a release of a short-circuit condition, or 3) a release of a current limit condition. Load capacitance determines exactly how high the output voltage will rise in response to these conditions. After 200 ms the converter will automatically restart.

**Over-Temperature Shutdown:** A temperature sensor on the converter senses the average temperature of the module. The thermal shutdown circuit is designed to turn the converter off when the temperature at the sensed location reaches the Over-Temperature Shutdown value. It will allow the converter to turn on again when the temperature of the sensed location falls by the amount of the Over-Temperature Shutdown Restart Hysteresis value.

## APPLICATION CONSIDERATIONS

**Input System Instability:** This condition can occur because any dc-dc converter appears incrementally as a negative resistance load. A detailed application note titled "Input System Instability" is available on the SynQor website which provides an understanding of why this instability arises, and shows the preferred solution for correcting it.

**Application Circuits:** Figure D below provides a typical circuit diagram which details the input filtering and voltage trimming.

**Input Filtering and External Capacitance:** Figure E below provides a diagram showing the internal input filter components. This filter dramatically reduces input terminal ripple current, which otherwise could exceed the rating of an external input electrolytic capacitor. The recommended external input capacitance is specified in the "Input Characteristics" section. More detailed information is available in the application note titled "EMI Characteristics" on the SynQor website.

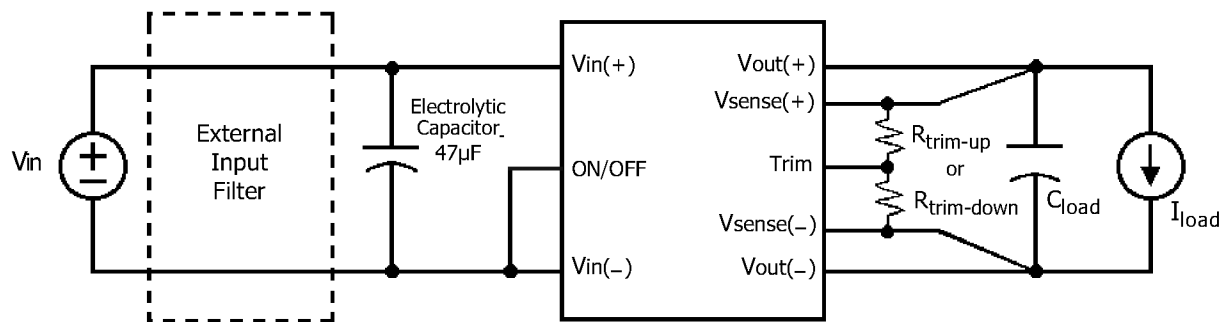

Figure D: Typical application circuit (negative logic unit, permanently enabled).

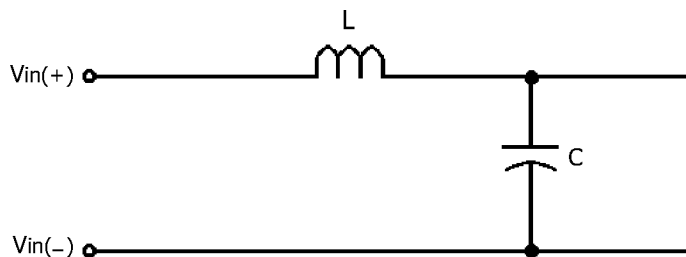

Figure E: Internal Input Filter Diagram (component values listed on the specifications page).

**Startup/ Restart Inhibit Period:** The Restart Inhibit Period ensures that the converter will remain off for approximately 200ms once it is shut down. When an output short is present, this generates a 5Hz "hiccup mode," which prevents the converter from overheating. In all, there are five ways that the converter can be shut down that initiate a Restart Inhibit Period:

- Input Under-Voltage Lockout
- Output Over-Voltage Protection
- Over Temperature Shutdown
- Current Limit
- Turned off by the ON/OFF input

Figure F shows turn-on scenarios, where a Restart Inhibit Period is initiated at  $t_1$ ,  $t_2$ , and  $t_3$ :

A Startup Inhibit Period is initiated when the input voltage is brought up from zero voltage during initial startup, beginning as the input voltage reaches approximately 10V. At the end of the Startup Inhibit Period (typically 10ms), if the ON/OFF pin has been active for at least 1ms, and the input voltage is above the Under-Voltage Lockout threshold, the output turns on with the Typical Turn-On Time. This is shown at time  $t_0$ .

At time  $t_1$ , the input voltage falls below the Input Under-Voltage Lockout threshold. This disables the unit and initiates a Restart Inhibit Period. During the Restart Inhibit Period, if the input voltage again exceeds the UVLO threshold, the unit cannot be enabled again until the Restart Inhibit Period has elapsed. Once this occurs, the output turns on with the Typical Turn-On Time.

At time  $t_2$ , the ON/OFF pin disables the unit and initiates a Restart Inhibit Period. During the Restart Inhibit Period, if the ON/OFF pin is again activated, the unit cannot be enabled again until the Restart Inhibit Period has elapsed. Once this occurs, the output turns on with the Typical Turn-On Time.

When the ON/OFF pin goes high after  $t_3$ , and the Restart Inhibit Period has elapsed, the output turns on approximately 1.6ms after the ON/OFF pin is activated, with the Typical Turn-On Time.

If the Under-Voltage Lockout threshold has not been satisfied at the end of either Inhibit Period, the unit will remain disabled until the input voltage exceeds the UVLO threshold. Once this occurs, the output turns on with the Typical Turn-On Time.

If the ON/OFF pin is activated after either Inhibit Period has elapsed, the output will turn on approximately 1.6ms after the ON/OFF pin is activated, with the Typical Turn-On Time.

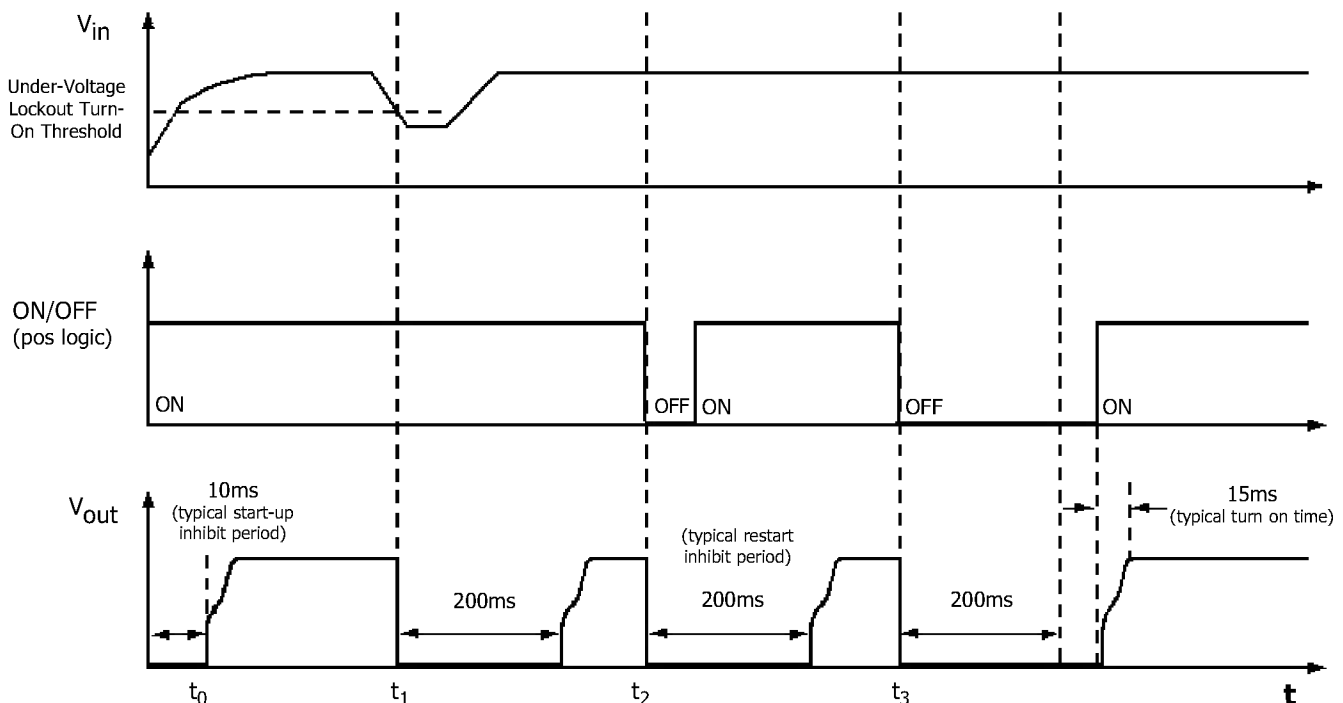
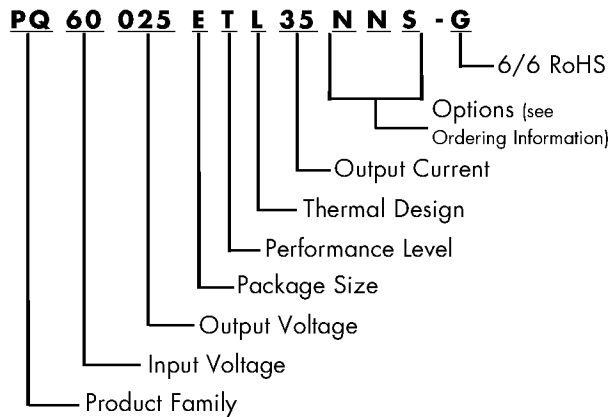

Figure F: Startup Inhibit Period (turn-on time not to scale)

### PART NUMBERING SYSTEM

The part numbering system for SynQor's PowerQor dc-dc converters follows the format shown in the example below.



The first 12 characters comprise the base part number and the last 3 characters indicate available options. Although there are no default values for enable logic and pin length, the most common options are negative logic and 0.145" pins. These part numbers are more likely to be readily available in stock for evaluation and prototype quantities. A "-G" suffix indicates the product is 6/6 RoHS compliant.

### Application Notes

A variety of application notes and technical white papers can be downloaded in pdf format from our website.

**RoHS Compliance:** The EU led RoHS (Restriction of Hazardous Substances) Directive bans the use of Lead, Cadmium, Hexavalent Chromium, Mercury, Polybrominated Biphenyls (PBB), and Polybrominated Diphenyl Ether (PBDE) in Electrical and Electronic Equipment. This SynQor product is available as 6/6 RoHS compliant. For more information please refer to SynQor's RoHS addendum available at our RoHS Compliance / Lead Free Initiative web page or e-mail us at rohs@synqor.com.

### Contact SynQor for further information:

**Phone:** 978-849-0600  
**Toll Free:** 888-567-9596  
**Fax:** 978-849-0602  
**E-mail:** power@synqor.com  
**Web:** www.synqor.com  
**Address:** 155 Swanson Road  
 Boxborough, MA 01719  
 USA

### ORDERING INFORMATION

The tables below show the valid model numbers and ordering options for converters in this product family. When ordering SynQor converters, please ensure that you use the complete 15 character part number consisting of the 12 character base part number and the additional 3 characters for options. A "-G" suffix indicates the product is 6/6 RoHS compliant.

Model Number	Input Voltage	Output Voltage	Max Output Current
<b>PQ60018ETL45xyz-G</b>	35 - 75 V	1.8 V	45 A
<b>PQ60025ETL35xyz-G</b>	35 - 75 V	2.5 V	35 A
<b>PQ60033ETL30xyz-G</b>	35 - 75 V	3.3 V	30 A

The following option choices must be included in place of the x y z spaces in the model numbers listed above.

Options Description: x y z		
Enable Logic	Pin Length	Feature Set
P - Positive N - Negative	K - 0.110" N - 0.145" R - 0.180" Y - 0.250"	S - Standard

### PATENTS

SynQor holds the following patents, one or more of which might apply to this product:

5,999,417	6,222,742	6,545,890	6,577,109
6,594,159	6,731,520	6,894,468	6,896,526
6,927,987	7,050,309	7,072,190	7,085,146
7,119,524	7,269,034	7,272,021	7,272,023

### Warranty

SynQor offers a three (3) year limited warranty. Complete warranty information is listed on our website or is available upon request from SynQor.

Information furnished by SynQor is believed to be accurate and reliable. However, no responsibility is assumed by SynQor for its use, nor for any infringements of patents or other rights of third parties which may result from its use. No license is granted by implication or otherwise under any patent or patent rights of SynQor.