

## FEATURES

- 525ps propagation delay
- 2.2GHz toggle frequency
- High bandwidth output transistions
- Internal 75K $\Omega$  input pull-down resistors
- Available in 8-pin SOIC package

## DESCRIPTION

The SY10/100EL35 are high-speed JK Flip-Flops. The J/K data enters the master portion of the flip-flop when the clock is LOW and is transferred to the slave and, thus, the outputs, upon a positive transition of the clock. The reset pin is asynchronous and is activated with a logic HIGH.

TRUTH TABLE<sup>(1)</sup>

J	K	R	CLK	Qn+1
L	L	L	Z	Qn
L	H	L	Z	L
H	L	L	Z	H
H	H	L	Z	$\bar{Q}_n$
X	X	H	X	L

## NOTE:

1. Z = LOW-to-HIGH transition.

**PACKAGE/ORDERING INFORMATION**

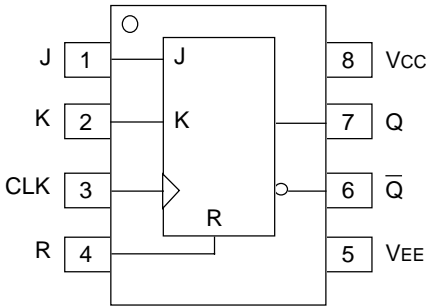

**8-PIN SOIC (Z8-1)**

**Ordering Information<sup>(1)</sup>**

Part Number	Package Type	Operating Range	Package Marking	Lead Finish
SY10EL35LZC	Z8-1	Commercial	HEL35	Sn-Pb
SY10EL35LZCTR <sup>(2)</sup>	Z8-1	Commercial	HEL35	Sn-Pb
SY100EL35LZC	Z8-1	Commercial	XEL35	Sn-Pb
SY100EL35LZCTR <sup>(2)</sup>	Z8-1	Commercial	XEL35	Sn-Pb
SY10EL35LZI	Z8-1	Industrial	HEL35	Sn-Pb
SY10EL35LZITR <sup>(2)</sup>	Z8-1	Industrial	HEL35	Sn-Pb
SY100EL35LZI	Z8-1	Industrial	XEL35	Sn-Pb
SY100EL35LZITR <sup>(2)</sup>	Z8-1	Industrial	XEL35	Sn-Pb
SY10EL35LZG <sup>(3)</sup>	Z8-1	Industrial	HEL35 with Pb-Free bar-line indicator	Pb-Free NiPdAu
SY10EL35LZGTR <sup>(2, 3)</sup>	Z8-1	Industrial	HEL35 with Pb-Free bar-line indicator	Pb-Free NiPdAu
SY100EL35LZG <sup>(3)</sup>	Z8-1	Industrial	XEL35 with Pb-Free bar-line indicator	Pb-Free NiPdAu
SY100EL35LZGTR <sup>(2, 3)</sup>	Z8-1	Industrial	XEL35 with Pb-Free bar-line indicator	Pb-Free NiPdAu

**Notes:**

1. Contact factory for die availability. Dice are guaranteed at T<sub>A</sub> = 25°C, DC Electricals only.
2. Tape and Reel.
3. Pb-Free package is recommended for new designs.

**DC ELECTRICAL CHARACTERISTICS**V<sub>EE</sub> = V<sub>EE</sub> (Min.) to V<sub>EE</sub> (Max.); V<sub>CC</sub> = GND

Symbol	Parameter	T <sub>A</sub> = -40°C			T <sub>A</sub> = 0°C			T <sub>A</sub> = +25°C			T <sub>A</sub> = +85°C			Unit
		Min.	Typ.	Max.	Min.	Typ.	Max.	Min.	Typ.	Max.	Min.	Typ.	Max.	
I <sub>EE</sub>	Power Supply Current	—	27	32	—	27	32	—	27	32	—	27	32	mA
	10EL	—	27	32	—	27	32	—	27	32	—	27	32	
	100EL	—	27	32	—	27	32	—	27	32	—	32	37	
V <sub>EE</sub>	Power Supply Voltage	—	-5.2	—	-4.75	-5.2	-5.5	-4.75	-5.2	-5.5	-4.75	-5.2	-5.5	V
	10EL	—	-4.5	—	-4.20	-4.5	-5.5	-4.20	-4.5	-5.5	-4.20	-4.5	-5.5	
	100EL	—	-4.5	—	-4.20	-4.5	-5.5	-4.20	-4.5	-5.5	-4.20	-4.5	-5.5	
I <sub>IH</sub>	Input HIGH Current	—	—	150	—	—	150	—	—	150	—	—	150	μA

**AC ELECTRICAL CHARACTERISTICS**V<sub>EE</sub> = V<sub>EE</sub> (Min.) to V<sub>EE</sub> (Max.); V<sub>CC</sub> = GND

Symbol	Parameter	T <sub>A</sub> = -40°C			T <sub>A</sub> = 0°C			T <sub>A</sub> = +25°C			T <sub>A</sub> = +85°C			Unit	
		Min.	Typ.	Max.	Min.	Typ.	Max.	Min.	Typ.	Max.	Min.	Typ.	Max.		
f <sub>MAX</sub>	Maximum Toggle Frequency	1.4	2.0	—	1.8	2.2	—	1.8	2.2	—	1.8	2.2	—	GHz	
t <sub>PD</sub>	Propagation Delay to Output	CLK	290	515	—	340	515	690	350	525	700	395	570	745	ps
		MR	225	450	—	275	450	625	275	450	625	350	525	700	
t <sub>S</sub>	Set-up Time	150	0	—	150	0	—	150	0	—	150	0	—	ps	
t <sub>H</sub>	Hold Time	250	100	—	250	100	—	250	100	—	250	100	—	ps	
t <sub>RR</sub>	Reset Recovery	400	200	—	400	200	—	400	200	—	400	200	—	ps	
t <sub>PW</sub>	Minimum Pulse Width CLK, Reset	400	—	—	400	—	—	400	—	—	400	—	—	ps	
t <sub>r</sub> t <sub>f</sub>	Output Rise/Fall Times Q (20% to 80%)	100	225	350	100	225	350	100	225	350	100	225	350	ps	

**8-PIN SOIC .150" WIDE (Z8-1)**

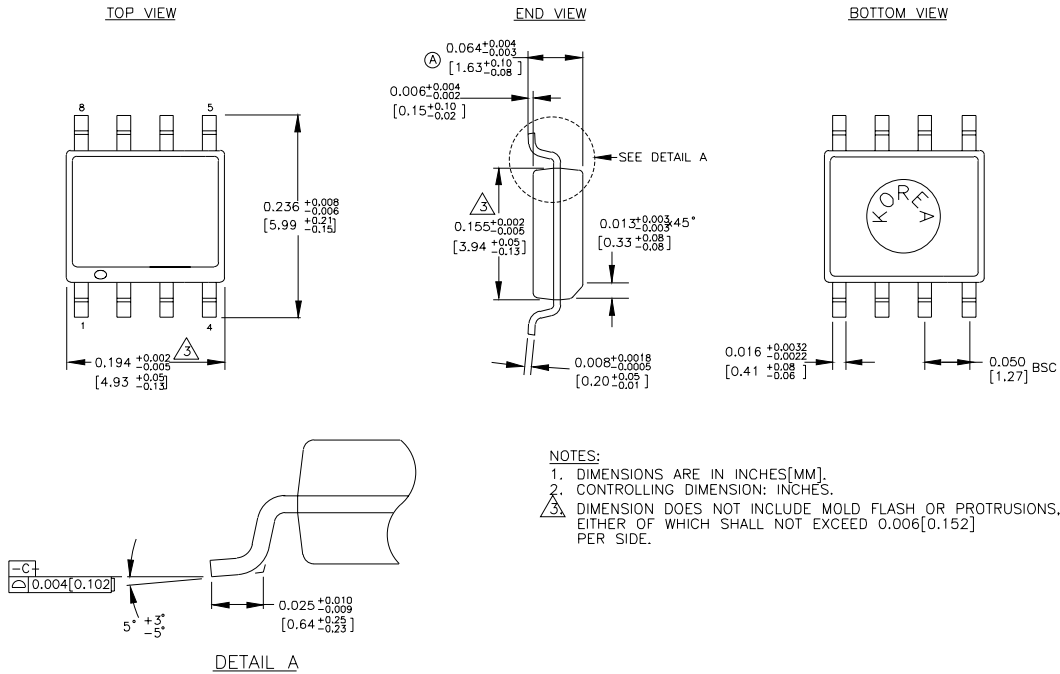

Rev. 03

**MICREL, INC. 2180 FORTUNE DRIVE SAN JOSE, CA 95131 USA**

TEL + 1 (408) 944-0800 FAX + 1 (408) 474-1000 WEB <http://www.micrel.com>

The information furnished by Micrel in this datasheet is believed to be accurate and reliable. However, no responsibility is assumed by Micrel for its use. Micrel reserves the right to change circuitry and specifications at any time without notification to the customer.

Micrel Products are not designed or authorized for use as components in life support appliances, devices or systems where malfunction of a product can reasonably be expected to result in personal injury. Life support devices or systems are devices or systems that (a) are intended for surgical implant into the body or (b) support or sustain life, and whose failure to perform can be reasonably expected to result in a significant injury to the user. A Purchaser's use or sale of Micrel Products for use in life support appliances, devices or systems is at Purchaser's own risk and Purchaser agrees to fully indemnify Micrel for any damages resulting from such use or sale.

© 2005 Micrel, Incorporated.