

REVISIONS				
REV.	ECO. NO	DESCRIPTION	DATE	BY
A	2406	INITIAL RELEASE	07/27/2011	GC

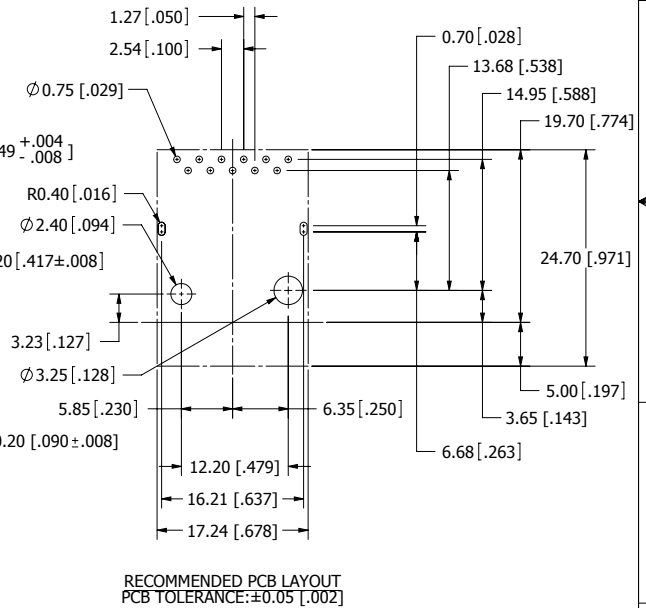
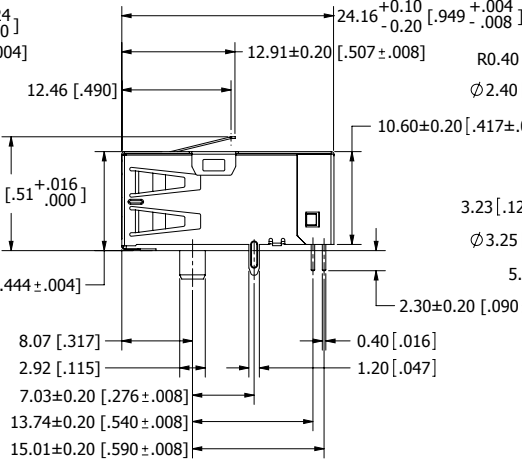
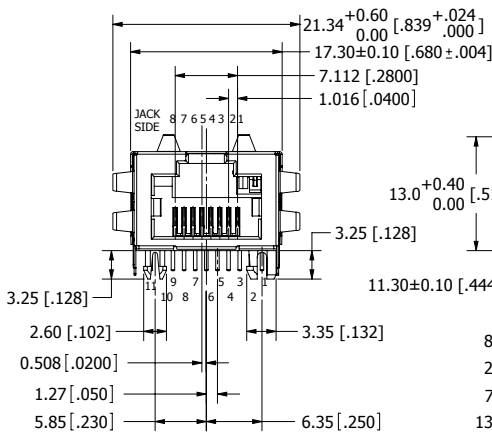
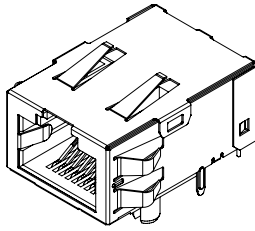
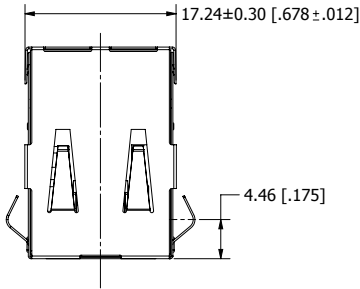

RoHS COMPLIANT

UNLESS OTHERWISE SPECIFIED: DIMENSIONS ARE IN MM [INCHES]	DRAWN	DATE	NAME	
		07/27/2011	GC	
TOLERANCES: X= ± 0.25 [01] XX= ± 0.15 [006] XXX= ± 0.10 [0040]	THE INFORMATION HEREIN CONTAINS PROPRIETARY INFORMATION OF SULLINS ELECTRONICS AND IS NOT TO BE REPRODUCED, COPIED OR DISCLOSED TO OTHERS FOR ANY PURPOSE EXCEPT AS SPECIFICALLY AUTHORIZED IN WRITING BY AN OFFICER OF SULLINS ELECTRONICS.			TITLE
	INTERPRET DIMENSIONS AND TOLERANCING PER: ASME Y14.5M-2009			
				PART NUMBER
				SMJ001-S88N-DS-11
	SIZE	CAGE CODE	DWG. NO.	REV
	C	54453	11817	A
	SCALE: 2:1			SHEET 1 OF 2

REVISIONS				
REV.	ECO. NO	DESCRIPTION	DATE	BY
A	2406	INITIAL RELEASE	07/27/2011	GC

NOTES:

- MATERIAL:
 HOUSING: PA46 TS250F6D 9B0040 UL94V-0
 OVERMOLD: LIQUID CRYSTAL POLYMER GLASS FILLED UL94V-0
 COIL BOX: LIQUID CRYSTAL POLYMER GLASS FILLED UL94V-0
 TERMINAL: COPPER ALLOY, .000039" MIN NICKEL UNDERPLATE,
 .000050" MIN GOLD ON CONTACT SURFACE,
 .000039" MIN TIN ON TERMINATION.
 TAIL: C2680 R-H, .000039" MIN NICKEL UNDERPLATE,
 .000039" MIN TIN ON TERMINATION.
 SHELL: C2680 R-H, .000039" MIN NICKEL UNDERPLATE,
 .000039" MIN TIN ON TERMINATION.

- MAGNETICS:
 IMPEDANCE: 100 OHMS
 TRANSMIT OPEN CIRCUIT INDUCTANCE: 350uH MINIMUM @100kHz
 TURNS RATIO(BOARD:CABLE): TX 1:1 RX 1:1
 TRANSMIT BIDIRECTIONAL ALL 4 PAIRS
 RECIEVE BIDIRECTIONAL ALL 4 PAIRS.

DIELECTRIC:CUT OFF CURRENT 1mA MAXIMUM IN 2250 VDC or 1500 VAC/ 1 MINUTE

TEST ITEM	FREQUENCY	SPECIFICATION REQUIREMENT
1 Insertion Loss	100KHz	1.2 dB MAXIMUM
	1~125MHz	0.2+0.002*(f MHz)^1.4 dB MAXIMUM
2 Return Loss	0.1~30MHz	16 dB MINIMUM
	30~60MHz	10-20*LOG ₁₀ (f MHz/60) dB MINIMUM
	60~100MHz	10 dB MINIMUM
3 Common Mode to Common Mode Rejection	2~20MHz	35 dB MINIMUM
	20~200MHz	15-20*LOG ₁₀ (f MHz/200) dB MINIMUM
4 Common Mode to Differential Mode Conversion	2~15MHz	40 dB MINIMUM
	16~200MHz	15-20*LOG ₁₀ (f MHz/200) dB MINIMUM
5 Near End Cross-Talk	1~15MHz	35 dB MINIMUM
	16~100MHz	24 dB MINIMUM

PCB SIDE

JACK SIDE

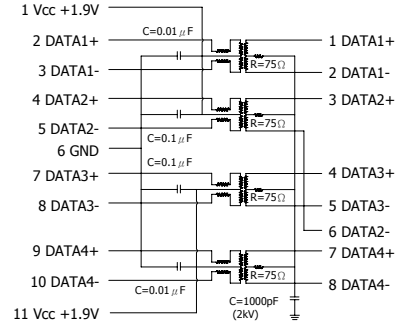

RoHS COMPLIANT

UNLESS OTHERWISE SPECIFIED: DIMENSIONS ARE IN MM(INCHES)	DRAWN	DATE	NAME	
		07/27/2011	GC	
TOLERANCES: X=+ 0.25 [.01] XX=+ 0.15 [.006] XXX=+ 0.10 [.0040]	THE INFORMATION HEREIN CONTAINS PROPRIETARY INFORMATION OF SULLINS ELECTRONICS AND IS NOT TO BE REPRODUCED, COPIED OR DISCLOSED TO OTHERS FOR ANY PURPOSE EXCEPT AS SPECIFICALLY AUTHORIZED IN WRITING BY AN OFFICER OF SULLINS ELECTRONICS.			TITLE
	INTERPRET DIMENSIONS AND TOLERANCING PER: ASME Y14.5M-2009			
	SIZE	CAGE CODE	DWG. NO.	REV
	C	54453	11817	A
	SCALE: 2:1	SHEET 2 OF 2		