



STP16DP05

Low voltage 16-bit constant current LED sink driver with outputs error detection

Features

- Low voltage power supply down to 3 V
- 16 constant current output channels
- Adjustable output current through external resistor
- Short and open output error detection
- Serial Data IN/Parallel data OUT
- 3.3 V micro driver-able
- Output current: 5-100 mA
- 30 MHz clock frequency
- Available in high thermal efficiency TSSOP exposed pad
- ESD protection 2.5 kV HBM, 200 V MM

Description

The STP16DP05 is a monolithic, low voltage, low current power 16-bit shift register designed for LED panel displays. The device contains a 16-bit serial-in, parallel-out shift register that feeds a 16-bit D-type storage register. In the output stage, sixteen regulated current sources were designed to provide 5-100 mA constant current to drive the LEDs.

The STP16DP05 features open and short LED detections on the outputs. The STP16DP05 is backward compatible with STP16C/L596. The detection circuit checks 3 different conditions that can occur on the output line: short to GND, short to V_O or open line.

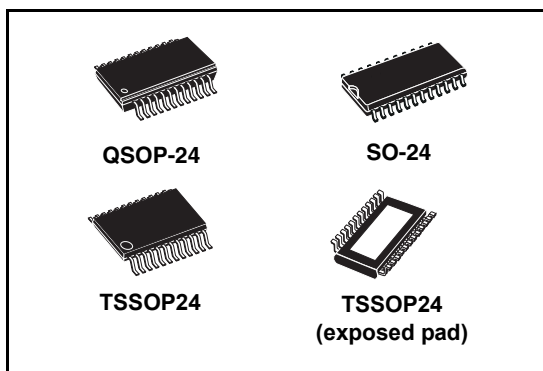

The data detection results are loaded in the shift register and shifted out via the serial line output.

The detection functionality is implemented without increasing the pin count number, through a secondary function of the output enable and latch pin (DM1 and DM2 respectively), a dedicated logic sequence allows the device to enter or leave from detection mode. Through an external resistor, users can adjust the STP16DP05 output current, controlling in this way the light intensity of LEDs, in addition, user can adjust LED's brightness intensity from 0 % to 100 % via $OE/DM2$ pin.

The STP16DP05 guarantees a 20 V output driving capability, allowing users to connect more LEDs in series. The high clock frequency, 30 MHz, makes the device suitable for high data rate transmission. The 3.3 V voltage supply is well useful for applications that interface any 3.3V micro. Compared with a standard TSSOP package, the TSSOP exposed pad increases heat dissipation capability by a 2.5 factor.

Table 1. Device summary

Order codes	Package	Packaging
STP16DP05MTR	SO-24 (tape and reel)	1000 parts per reel
STP16DP05TTR	TSSOP24 (tape and reel)	2500 parts per reel
STP16DP05XTTR	TSSOP24 exposed pad (tape and reel)	2500 parts per reel
STP16DP05PTR	QSOP-24	2500 parts per reel

Contents

1	Summary description	3
1.1	Pin connection and description	3
2	Electrical ratings	4
2.1	Absolute maximum ratings	4
2.2	Thermal data	4
2.3	Recommended operating conditions	5
3	Electrical characteristics	6
4	Equivalent circuit and outputs	8
5	Timing diagrams	10
6	Typical characteristics	13
7	Detection mode functionality	16
7.1	Phase one: “entering in detection mode”	16
7.2	Phase two: “error detection”	17
7.3	Phase three: “resuming to normal mode”	19
7.4	Error detection conditions	19
8	Package mechanical data	21
9	Revision history	28

1 Summary description

Table 2. Typical current accuracy

Output voltage	Current accuracy		Output current	V _{DD}	Temperature
	Between bits	Between ICs			
≥ 1.3 V	±1.5 %	±5 %	20 to 100 mA	3.3 V to 5 V	25 °C

1.1 Pin connection and description

Figure 1. Pin connection

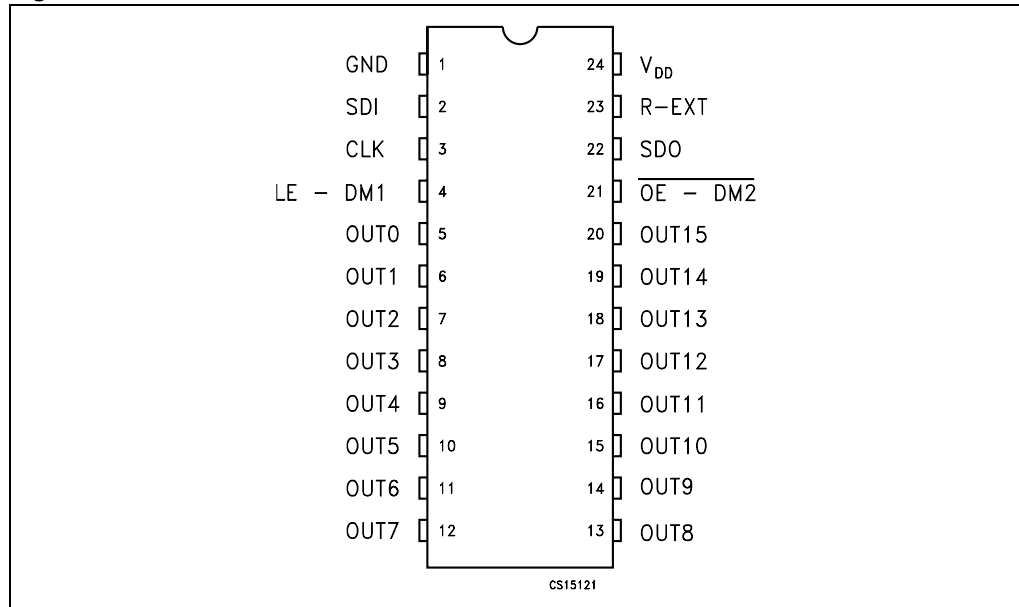

Note: The exposed pad is electrically not connected

Table 3. Pin description

Pin N°	Symbol	Name and function
1	GND	Ground terminal
2	SDI	Serial data input terminal
3	CLK	Clock input terminal
4	LE-DM1	Latch input terminal - Detect mode 1 (see operation principle)
5-20	OUT 0-15	Output terminal
21	$\overline{\text{OE-DM2}}$	Input terminal of output enable (active low) - Detect mode 1 (see operation principle)
22	SDO	Serial data out terminal
23	R-EXT	Input terminal of an external resistor for constant current programming
24	V _{DD}	Supply voltage terminal

2 Electrical ratings

2.1 Absolute maximum ratings

Stressing the device above the rating listed in the “absolute maximum ratings” table may cause permanent damage to the device. These are stress ratings only and operation of the device at these or any other conditions above those indicated in the operating sections of this specification is not implied. Exposure to absolute maximum rating conditions for extended periods may affect device reliability. Refer also to the STMicroelectronics SURE Program and other relevant quality documents.

Table 4. Absolute maximum ratings

Symbol	Parameter	Value	Unit
V_{DD}	Supply voltage	0 to 7	V
V_O	Output voltage	-0.5 to 20	V
I_O	Output current	100	mA
V_I	Input voltage	-0.4 to V_{DD}	V
I_{GND}	GND terminal current	1600	mA
f_{CLK}	Clock frequency	50	MHz

2.2 Thermal data

Table 5. Thermal data

Symbol	Parameter	Value	Unit	
T_{OPR}	Operating temperature range	-40 to +125	°C	
T_{STG}	Storage temperature range	-55 to +150	°C	
R_{thJC}	Thermal resistance junction-case	SO-24	60	°C/W
		TSSOP24	85	°C/W
		TSSOP24 ⁽¹⁾ Exposed Pad	37.5	°C/W
		QSOP-24	72	°C/W

1. The exposed pad should be soldered directly to the PCB to realize the thermal benefits.

2.3 Recommended operating conditions

Table 6. Recommended operating conditions

Symbol	Parameter	Test conditions	Min	Typ	Max	Unit
V_{DD}	Supply voltage		3.0		5.5	V
V_O	Output voltage				20	V
I_O	Output current	OUTn	5		100	mA
I_{OH}	Output current	SERIAL-OUT			+1	mA
I_{OL}	Output current	SERIAL-OUT			-1	mA
V_{IH}	Input voltage		$0.7V_{DD}$		$V_{DD}+0.3$	V
V_{IL}	Input voltage		-0.3		$0.3V_{DD}$	V
t_{wLAT}	LE\DM1 pulse width	$V_{DD} = 3.0\text{ V to }5.0\text{ V}$	20			ns
t_{wCLK}	CLK pulse width		20			ns
t_{wEN}	$\overline{OE}\overline{DM2}$ pulse width		200			ns
$t_{SETUP(D)}$	Setup time for DATA		20			ns
$t_{HOLD(D)}$	Hold time for DATA		15			ns
$t_{SETUP(L)}$	Setup time for LATCH		15			ns
f_{CLK}	Clock frequency		Cascade operation ⁽¹⁾			30

1. If the device is connected in cascade, it may not be possible to achieve the maximum data transfer. Please consider the timings carefully.

3 Electrical characteristics

Table 7. Electrical characteristics
($V_{DD} = 3.3\text{ V to }5\text{ V}$, $T = 25\text{ }^{\circ}\text{C}$, unless otherwise specified.)

Symbol	Parameter	Test conditions	Min	Typ	Max	Unit
V_{IH}	Input voltage high level		$0.7V_{DD}$		V_{DD}	V
V_{IL}	Input voltage low level		GND		$0.3V_{DD}$	V
I_{OH}	Output leakage current	$V_{OH} = 20\text{ V}$			10	μA
V_{OL}	Output voltage (Serial-OUT)	$I_{OL} = 1\text{ mA}$			0.4	V
V_{OH}	Output voltage (Serial-OUT)	$I_{OH} = -1\text{ mA}$	$V_{OH} - V_{DD} = -0.4\text{ V}$			V
I_{OL1}	Output current	$V_O = 0.3\text{ V}$, $R_{ext} = 3.9\text{ k}\Omega$	4.25	5	5.75	mA
I_{OL2}		$V_O = 0.3\text{ V}$, $R_{ext} = 970\ \Omega$	19	20	21	
I_{OL3}		$V_O = 1.3\text{ V}$, $R_{ext} = 190\ \Omega$	96	100	104	
ΔI_{OL1}	Output current error between bit (All Output ON)	$V_O = 0.3\text{ V}$, $R_{EXT} = 3.9\text{ k}\Omega$		± 5	± 8	%
ΔI_{OL2}		$V_O = 0.3\text{ V}$, $R_{EXT} = 970\ \Omega$		± 1.5	± 3	
ΔI_{OL3}		$V_O = 1.3\text{ V}$, $R_{EXT} = 190\ \Omega$		± 1.2	± 3	
$R_{SIN(up)}$	Pull-up resistor		150	300	600	$\text{K}\Omega$
$R_{SIN(down)}$	Pull-down resistor		100	200	400	$\text{K}\Omega$
$I_{DD(OFF1)}$	Supply current (OFF)	$R_{EXT} = 970$ OUT 0 to 15 = OFF		4	5	mA
$I_{DD(OFF2)}$		$R_{EXT} = 240$ OUT 0 to 15 = OFF		11.2	13.5	
$I_{DD(ON1)}$	Supply current (ON)	$R_{EXT} = 970$ OUT 0 to 15 = ON		4.5	5	
$I_{DD(ON2)}$		$R_{EXT} = 240$ OUT 0 to 15 = ON		11.7	13.5	
Thermal	Thermal protection ⁽¹⁾			170		$^{\circ}\text{C}$

1. Guaranteed by desing (not tested)
The thermal protection switches OFF only the outputs current

Table 8. Switching characteristics ($V_{DD} = 5\text{ V}$, $T = 25\text{ }^{\circ}\text{C}$, unless otherwise specified.)

Symbol	Parameter	Test conditions	Min	Typ	Max	Unit	
t_{PLH1}	Propagation delay time, CLK-OUTn, LE\DM1 = H, OE\DM2 = L	$V_{DD} = 3.3\text{ V}$ $V_{IH} = V_{DD}$ $V_{IL} = \text{GND}$ $C_L = 10\text{ pF}$ $I_O = 20\text{ mA}$ $V_L = 3.0\text{ V}$ $R_{EXT} = 1\text{ K}\Omega$ $R_L = 60\ \Omega$	$V_{DD} = 3.3\text{ V}$		70	105	ns
			$V_{DD} = 5\text{ V}$		45	65	
t_{PLH2}	Propagation delay time, LE\DM1 -OUTn, OE\DM2 = L		$V_{DD} = 3.3\text{ V}$		61	90	ns
			$V_{DD} = 5\text{ V}$		41	60	
t_{PLH3}	Propagation delay time, OE\DM2-OUTn, LE\DM1 = H		$V_{DD} = 3.3\text{ V}$		69	105	ns
			$V_{DD} = 5\text{ V}$		50	70	
t_{PLH}	Propagation delay time, CLK-SDO		$V_{DD} = 3.3\text{ V}$		14	20	ns
			$V_{DD} = 5\text{ V}$		8	12	
t_{PHL1}	Propagation delay time, CLK-OUTn, LE\DM1 = H, OE\DM2 = L		$V_{DD} = 3.3\text{ V}$		34	50	ns
			$V_{DD} = 5\text{ V}$		23	35	
t_{PHL2}	Propagation delay time, LE\DM1 -OUTn, OE\DM2 = L		$V_{DD} = 3.3\text{ V}$		27	40	ns
			$V_{DD} = 5\text{ V}$		22	32	
t_{PHL3}	Propagation delay time, OE\DM2-OUTn, LE\DM1 = H	$V_{DD} = 3.3\text{ V}$		23	35	ns	
		$V_{DD} = 5\text{ V}$		20	30		
t_{PHL}	Propagation delay time, CLK-SDO	$V_{DD} = 3.3\text{ V}$		15	25	ns	
		$V_{DD} = 5\text{ V}$		9	15		
t_{ON}	Output rise time 10~90% of voltage waveform	$V_{DD} = 3.3\text{ V}$		42	65	ns	
		$V_{DD} = 5\text{ V}$		35	55		
t_{OFF}	Output fall time 90~10% of voltage waveform	$V_{DD} = 3.3\text{ V}$		10	16	ns	
		$V_{DD} = 5\text{ V}$		9	14		
t_r	CLK rise time ⁽¹⁾				5000	ns	
t_f	CLK fall time ⁽¹⁾				5000	ns	

1. In order to achieve high cascade data transfer, please consider t_r/t_f timings carefully.

4 Equivalent circuit and outputs

Figure 2. $\overline{OE\backslash DM2}$ terminal

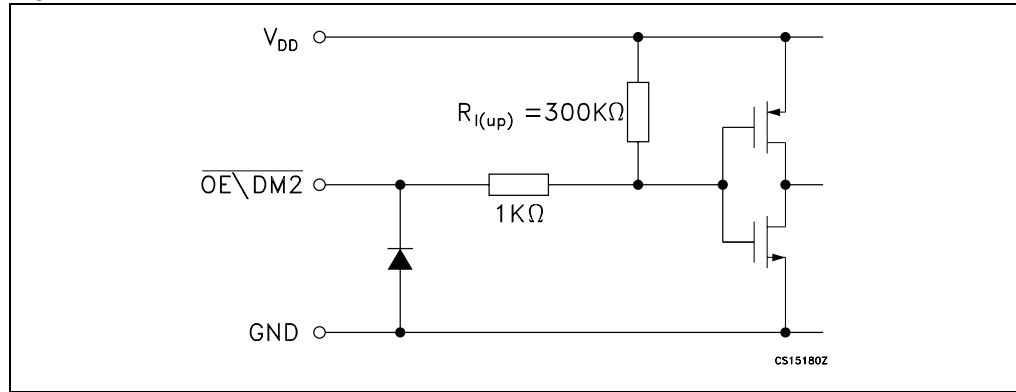

Figure 3. $LE\backslash DM1$ terminal

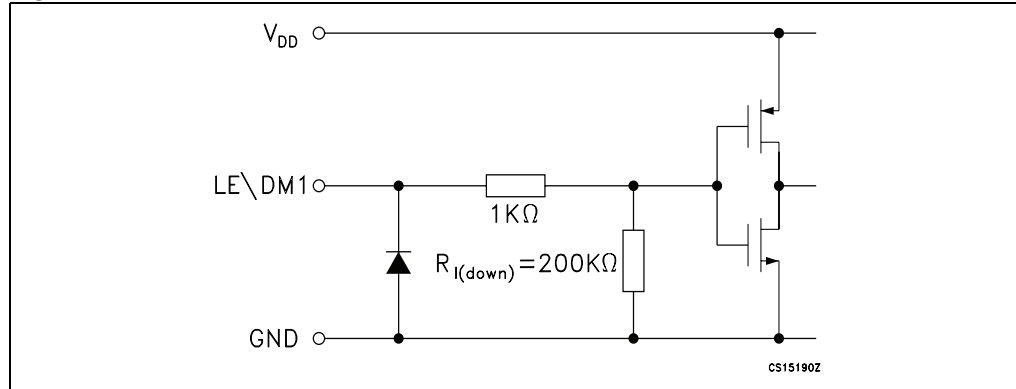

Figure 4. CLK, SDI terminal

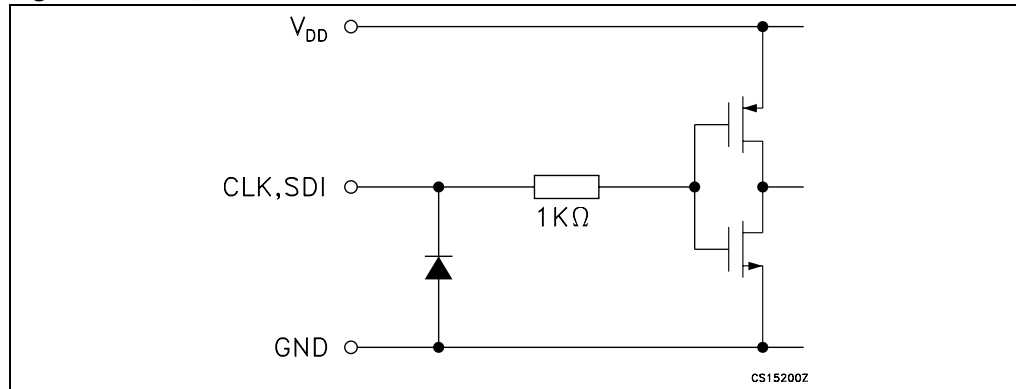

Figure 5. SDO terminal

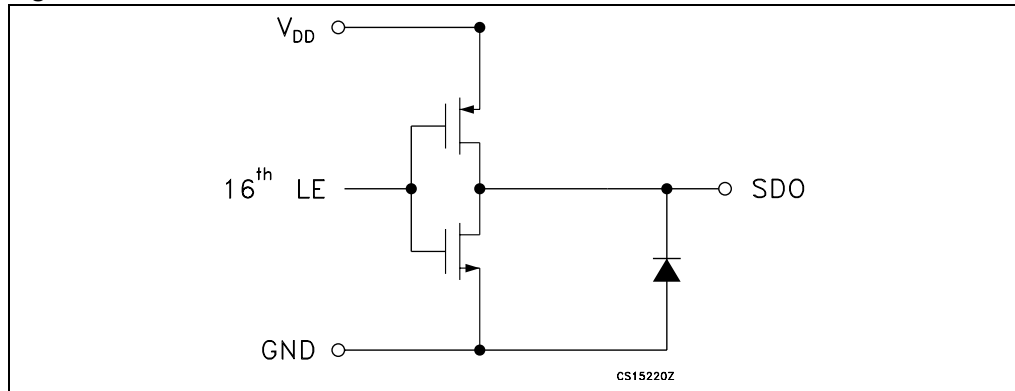
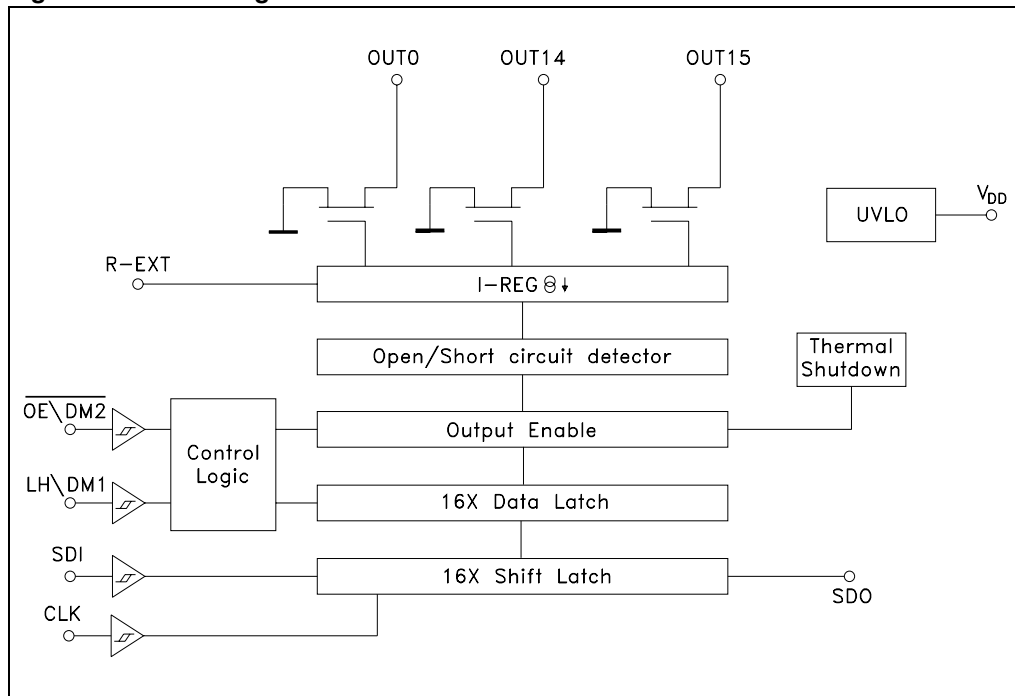

Figure 6. Block diagram



5 Timing diagrams

Table 9. Truth table

CLOCK	LE\DM1	$\overline{OE}\overline{DM2}$	SERIAL-IN	OUT0 OUT7 OUT15	SDO
	H	L	Dn	Dn Dn - 7 Dn -15	Dn - 15
	L	L	Dn + 1	No change	Dn - 14
	H	L	Dn + 2	Dn + 2 Dn - 5 Dn -13	Dn - 13
	X	L	Dn + 3	Dn + 2 Dn - 5 Dn -13	Dn - 13
	X	H	Dn + 3	OFF	Dn - 13

Note: $OUTn = ON$ when $Dn = H$ $OUTn = OFF$ when $Dn = L$

Figure 7. Timing diagram

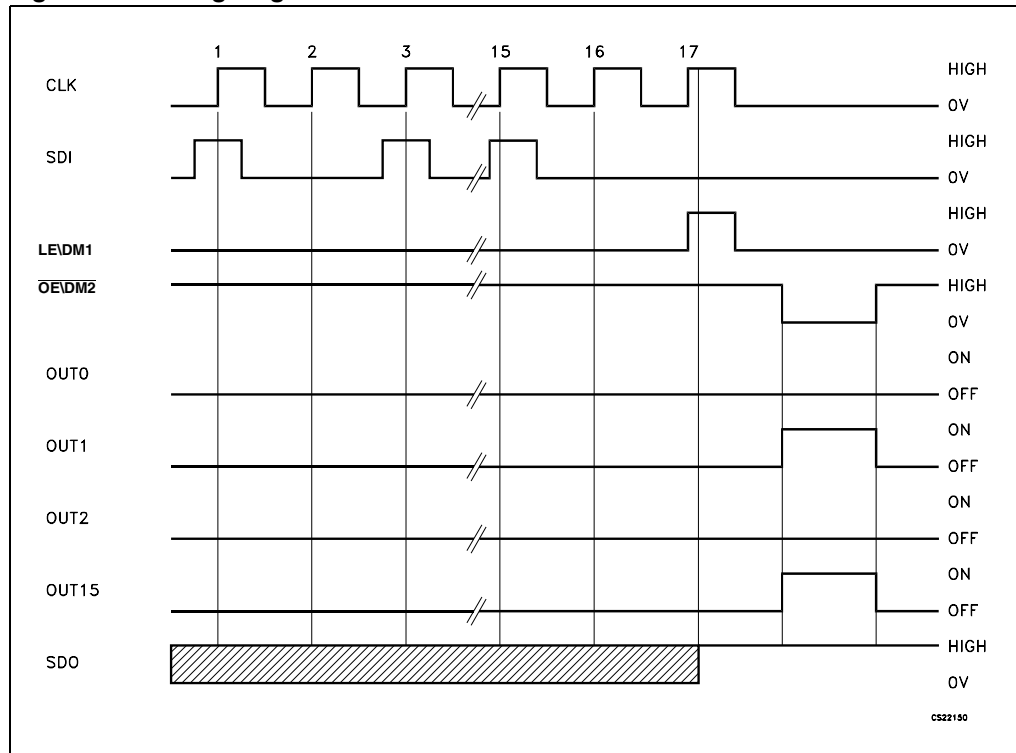

Note: The latches circuit holds data when the LE\DM1 terminal is Low.

- 1 When LE\DM1 terminal is at High level, latch circuit hold the data it passes from the input to the output.
- 2 When $\overline{OE}\overline{DM2}$ terminal is at Low level, output terminals OUT0 to OUT15 respond to the data, either ON or OFF.
- 3 When $\overline{OE}\overline{DM2}$ terminal is at High level, it switches off all the data on the output terminal.

Figure 8. Clock, serial-in, serial-out

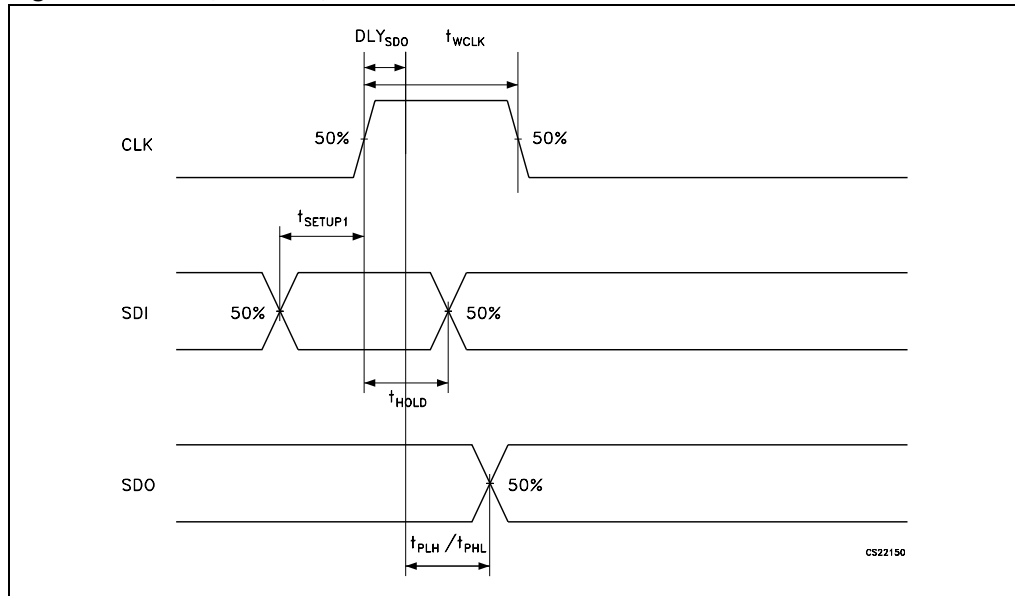

Figure 9. Clock, serial-in, latch, enable, outputs

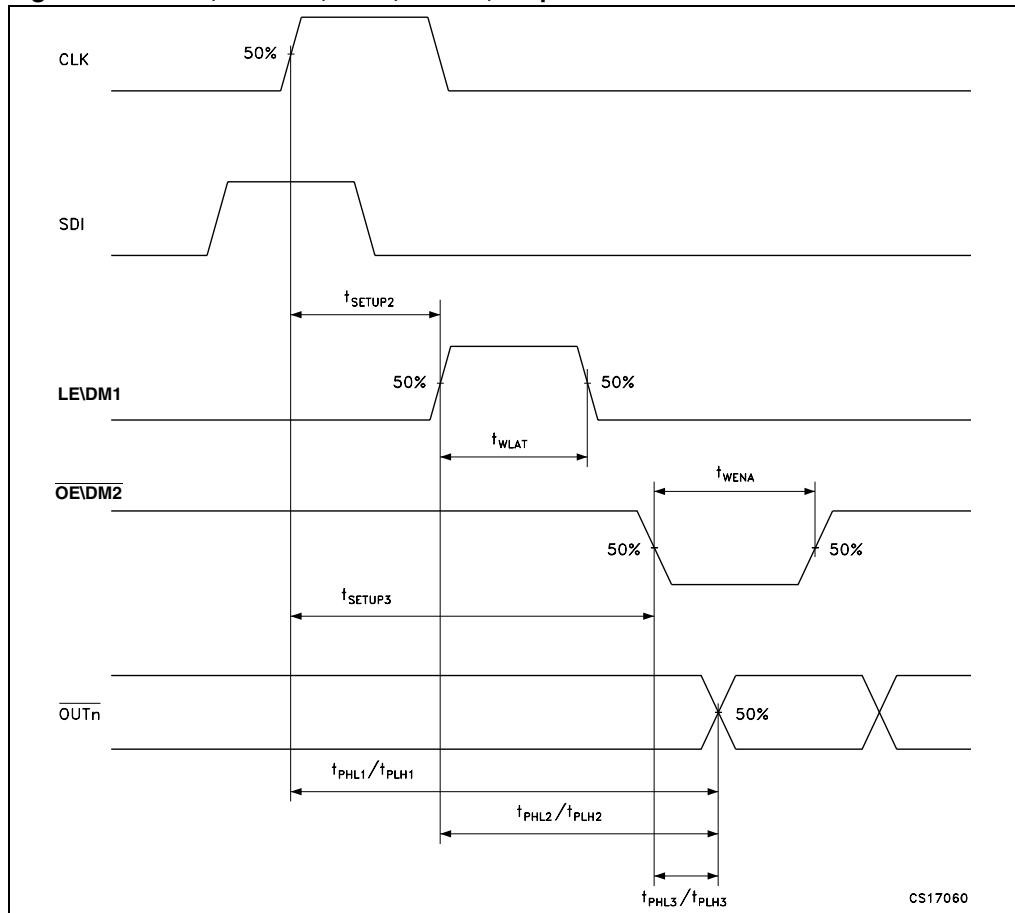
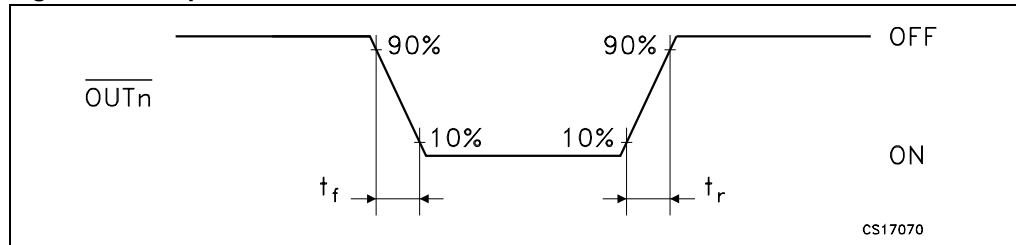

Figure 10. Outputs



6 Typical characteristics

Figure 11. Output current- R_{EXT} resistor

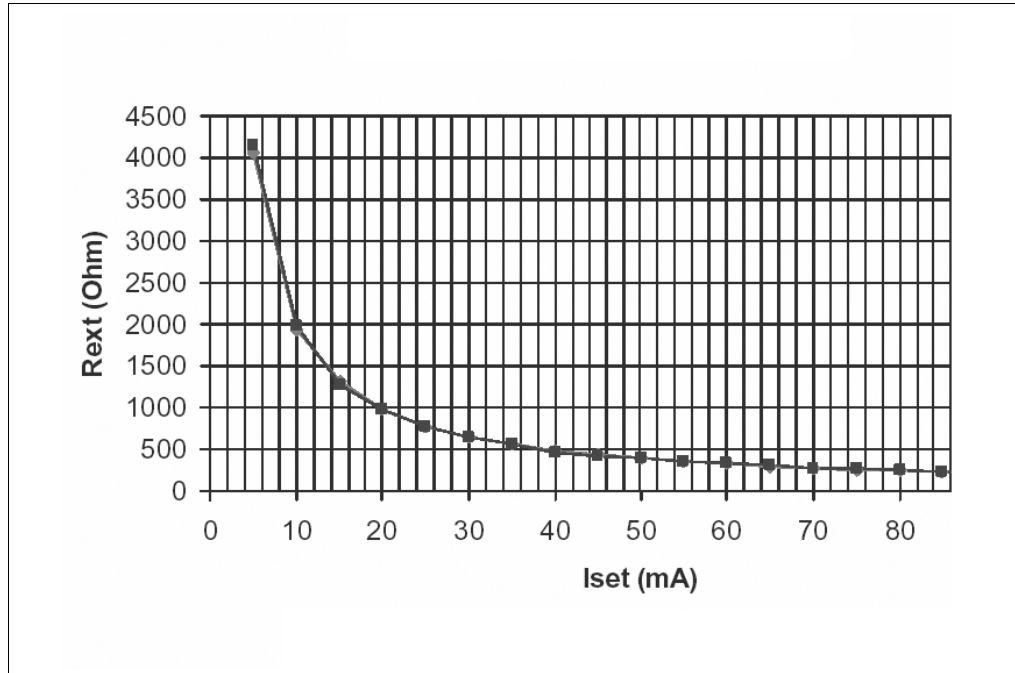

Table 10. Output current- R_{EXT} resistor

R_{ext} (Ω)	Output current (mA)
976	20
780	25
652	30
560	35
488	40
433	45
389	50
354	55
325	60
300	65
278	70
259	75
241	80
229	85
215	90

Conditions:
 Temperature = 25 °C, $V_{DD} = 3.3\text{ V}; 5.0\text{ V}$, $I_{SET} = 3\text{ mA}; 5\text{ mA}; 10\text{ mA}; 20\text{ mA}; 50\text{ mA}; 80\text{ mA}$.

Figure 12. I_{SET} vs drop out voltage (V_{drop})

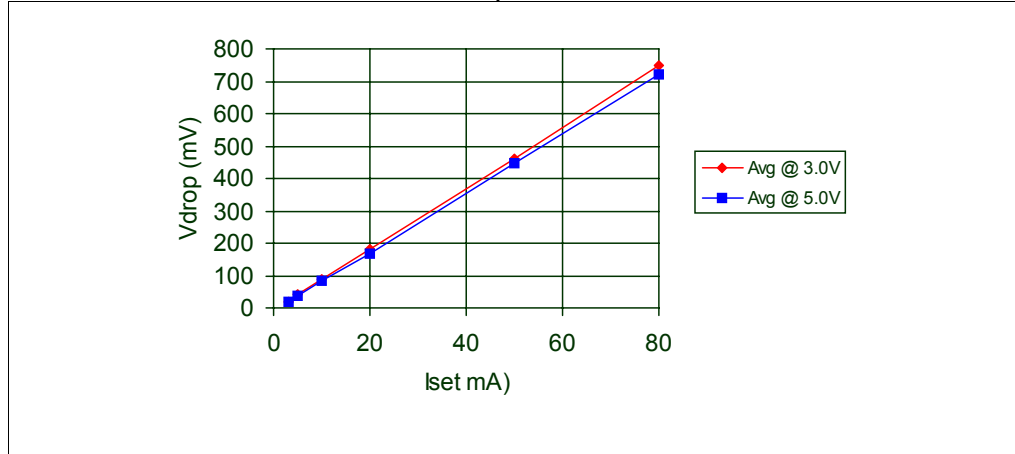

Table 11. I_{SET} vs drop out voltage (V_{drop})

I_{out} (mA)	Avg @ 3.0 V	Avg @ 5.0 V
3	19.33	22.66
5	36.67	40.33
10	77.33	80
20	158.67	157.33
50	406	406
80	692	668

Figure 13. I_{DD} ON/OFF

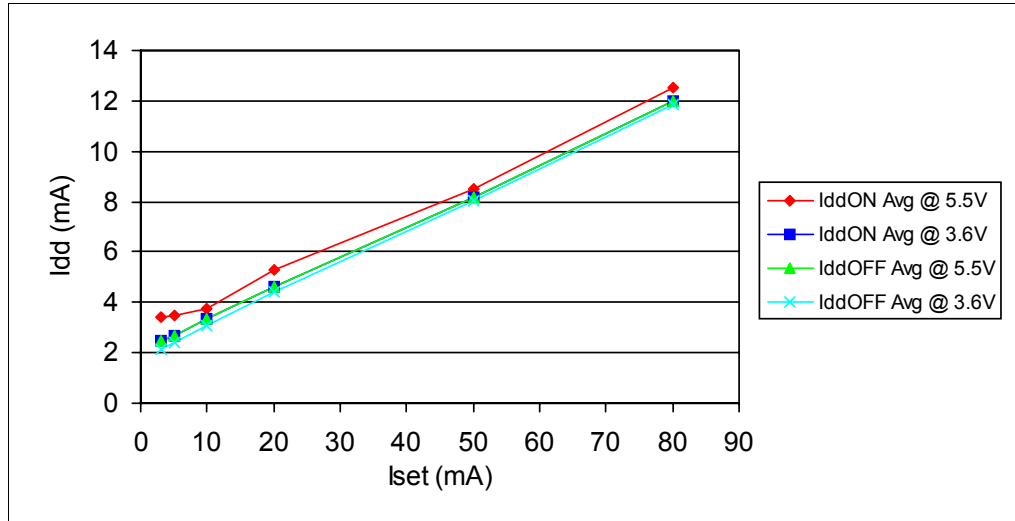
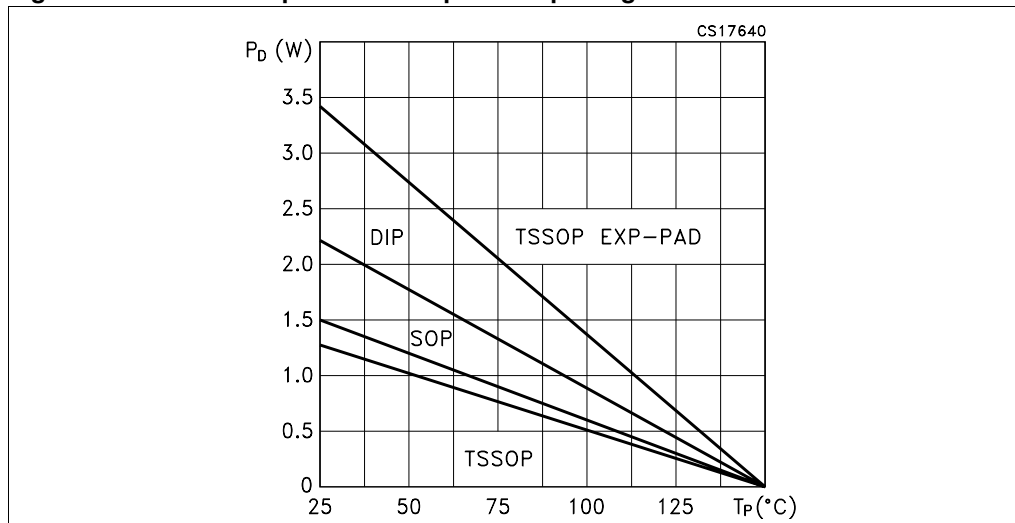

Figure 14. Power dissipation vs temperature package



Note: The exposed pad should be soldered to the PBC to realize the thermal benefits.

7 Detection mode functionality

7.1 Phase one: “entering in detection mode“

From the “normal mode” condition the device can switch to the “error mode“ by a logic sequence on the $\overline{OE}/DM2$ and LE/DM1 pins as showed in the following table and diagram:

Table 12. Entering in detection truth table

CLK	1°	2°	3°	4°	5°
$\overline{OE}/DM2$	H	L	H	H	H
LE/DM1	L	L	L	H	L

Figure 15. Entering in detection timing diagram

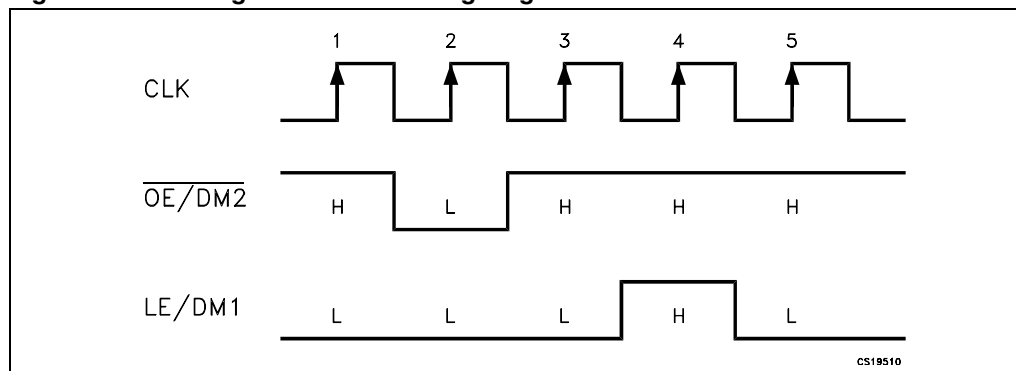

After these five CLK cycles the device goes into the “error detection mode“ and at the 6th rise front of CLK the SDI data are ready for the sampling.

7.2 Phase two: “error detection”

The 16 data bits must be set “1” in order to set ON all the outputs during the detection. The data are latched by LE/DM1 and after that the outputs are ready for the detection process. When the Micro controller switches the $\overline{OE/DM2}$ to LOW, the device drives the LEDs in order to analyze if an OPEN or SHORT condition has occurred.

Figure 16. Detection diagram

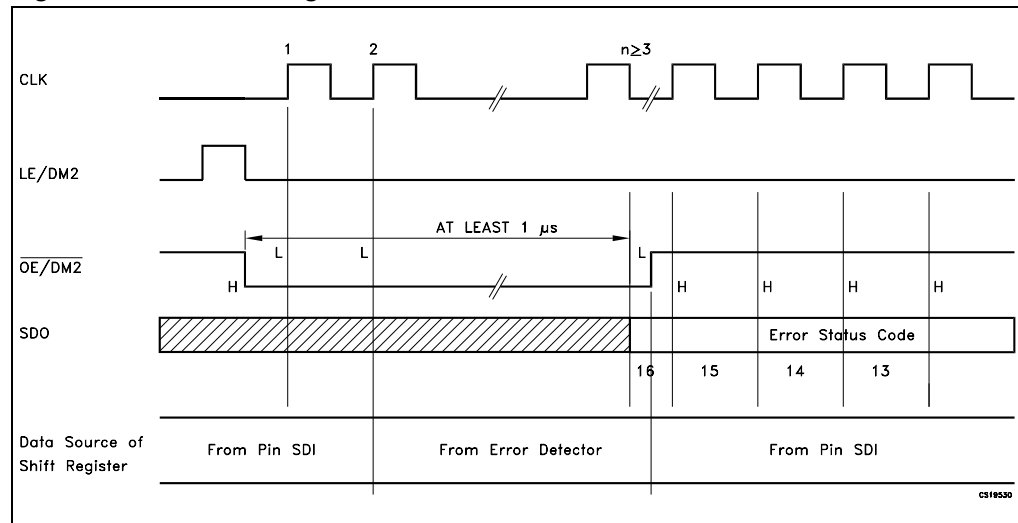

The LEDs status will be detected at least in 1 microsecond and after this time the microcontroller sets $\overline{OE/DM2}$ in HIGH state and the output data detection result will go to the microprocessor via SDO.

Detection mode and normal mode use both the same format data. As soon as all the detection data bits are available on the serial line, the device may go back to normal mode of operation. To re-detect the status the device must go back in normal mode and re-entering in error detection mode .

Figure 17. Timing example for open and/or short detection

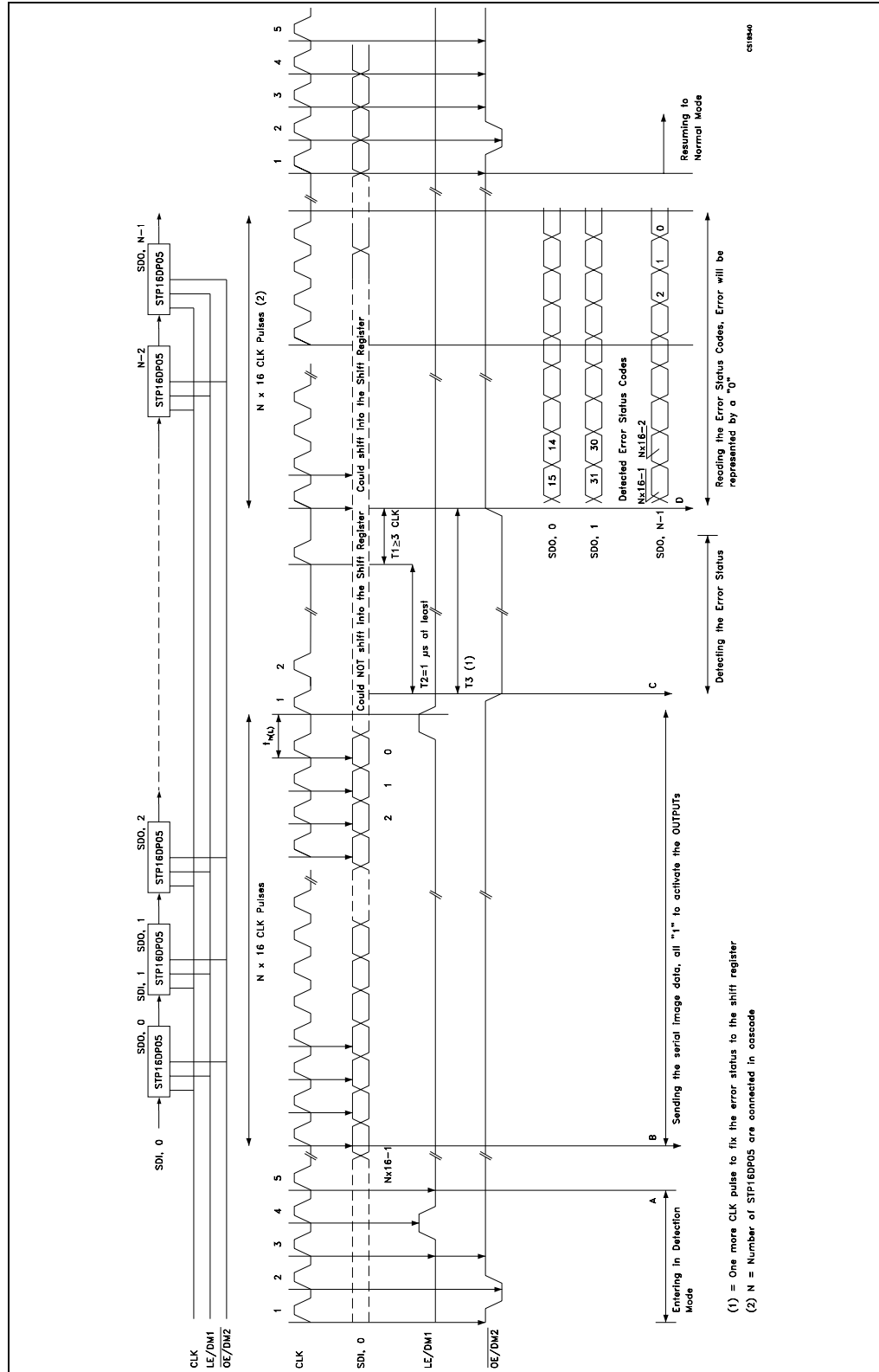

7.3 Phase three: “resuming to normal mode”

The sequence for re-entering in normal mode is showed in the following Table and diagram:

Figure 18. Resuming to normal mode timing diagram

CLK	1°	2°	3°	4°	5°
$\overline{\text{OE/DM2}}$	H	L	H	H	H
LE/DM1	L	L	L	L	L

Note: For proper device operation the "Entering in detection" sequence must be follow by a "Resume Mode" sequence, it is not possible to insert consecutive equal sequence.

7.4 Error detection conditions

Table 13. Detection conditions ($V_{DD} = 3.3$ to 5 V temperature range -40 to 125 °C)

SW-1 or SW-3b	Open line or output short to GND detected	$\implies I_{ODEC} \leq 0.5 \times I_O$	No error detected	$\implies I_{ODEC} \geq 0.5 \times I_O$
SW-2 or SW-3a	Short on LED or short to V-LED detected	$\implies V_O \geq 2.4$ V	No error detected	$\implies V_O \leq 2.2$ V

Note: Where: I_O = the output current programmed by the R_{EXT} , I_{ODEC} = the detected output current in detection mode

Figure 19. Detection circuit

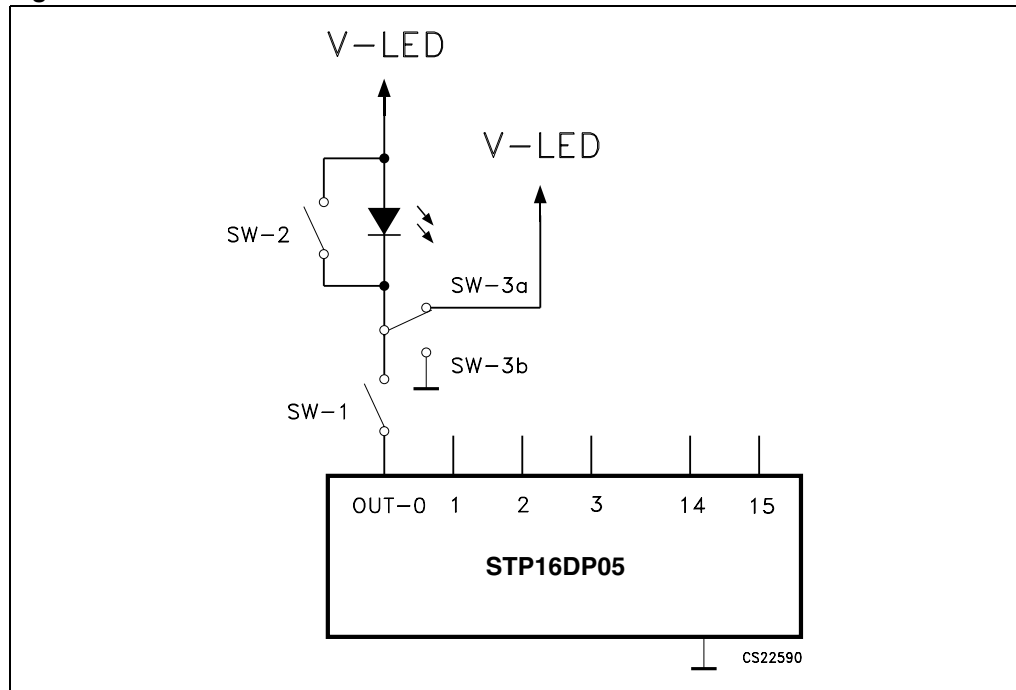
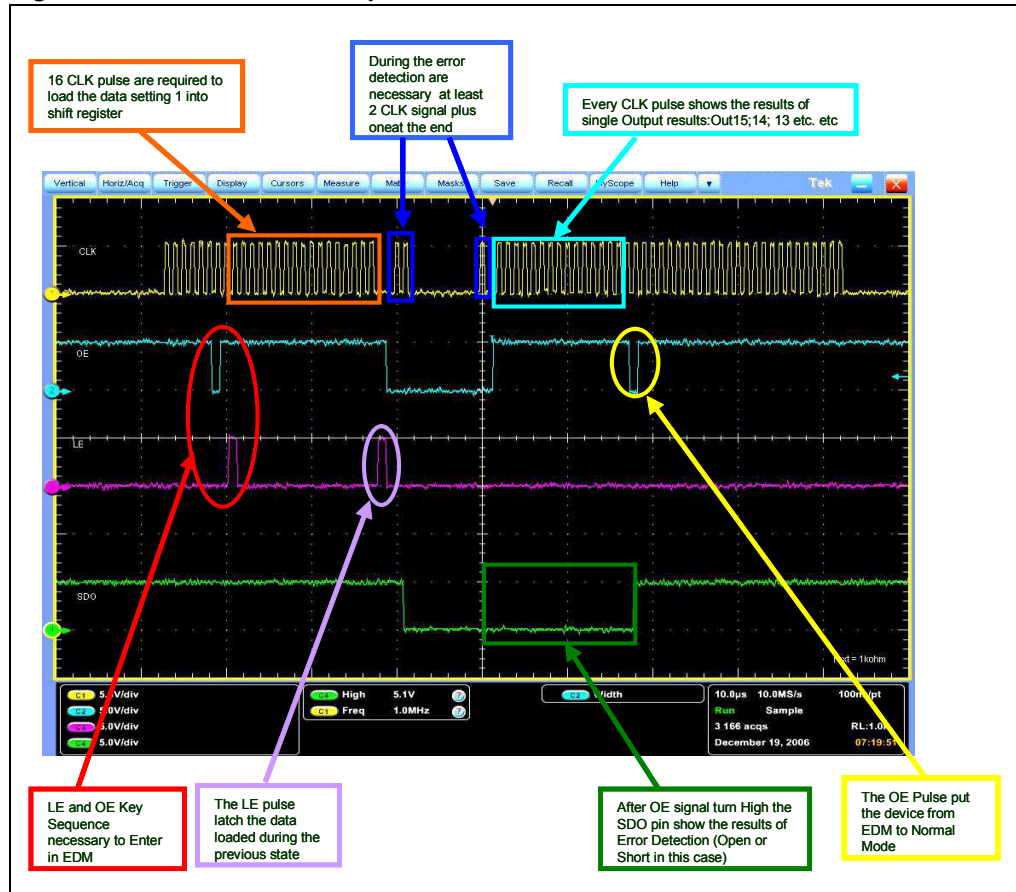

Figure 20. Error detection sequence



8 Package mechanical data

In order to meet environmental requirements, ST offers these devices in ECOPACK® packages. These packages have a lead-free second level interconnect. The category of second level interconnect is marked on the package and on the inner box label, in compliance with JEDEC Standard JESD97. The maximum ratings related to soldering conditions are also marked on the inner box label. ECOPACK is an ST trademark. ECOPACK specifications are available at: www.st.com

Table 14. QSOP-24 mechanical data

Dim.	mm.			inch		
	Min	Typ	Max	Min	Typ	Max
A	1.54	1.62	1.73	0.061	0.064	0.068
A1	0.1	0.15	0.25	0.004	0.006	0.010
A2		1.47			0.058	
b	0.31	0.2		0.012	0.008	
c	0.254	0.17		0.010	0.007	
D	8.56	8.66	8.76	0.337	0.341	0.345
E	5.8	6	6.2	0.228	0.236	0.244
E1	3.8	3.91	4.01	0.150	0.154	0.158
e		0.635			0.025	
L	0.4	0.635	0.89	0.016	0.025	0.035
h	0.25	0.33	0.41	0.010	0.013	0.016
<	8°	0°				

Figure 21. QSOP-24 package dimensions

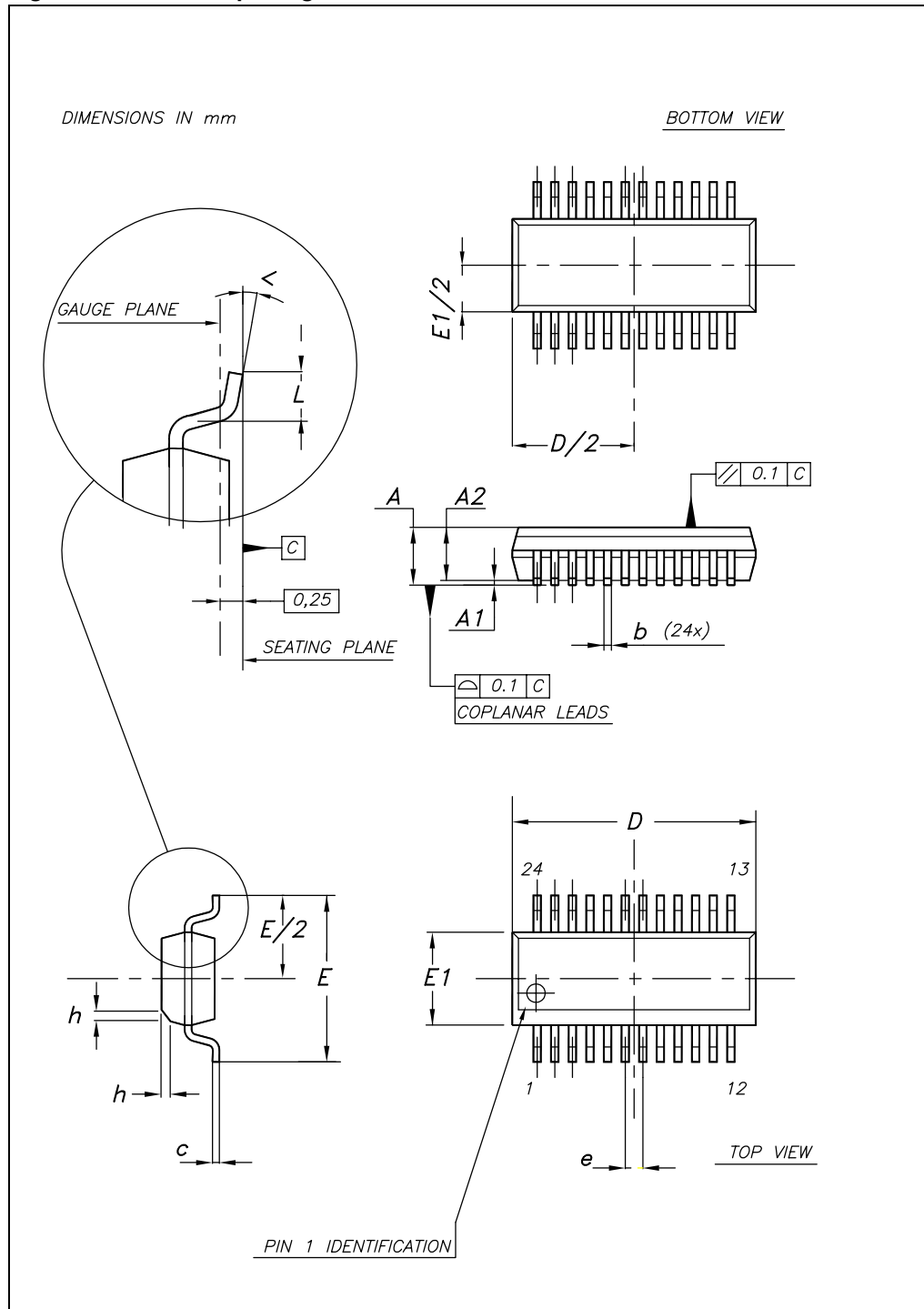

Table 15. TSSOP24 mechanical data

Dim.	mm.			inch		
	Min	Typ	Max	Min	Typ	Max
A			1.1			0.043
A1	0.05		0.15	0.002		0.006
A2		0.9			0.035	
b	0.19		0.30	0.0075		0.0118
c	0.09		0.20	0.0035		0.0079
D	7.7		7.9	0.303		0.311
E	4.3		4.5	0.169		0.177
e		0.65 BSC			0.0256 BSC	
H	6.25		6.5	0.246		0.256
K	0°		8°	0°		8°
L	0.50		0.70	0.020		0.028

Figure 22. TSSOP24 package dimensions

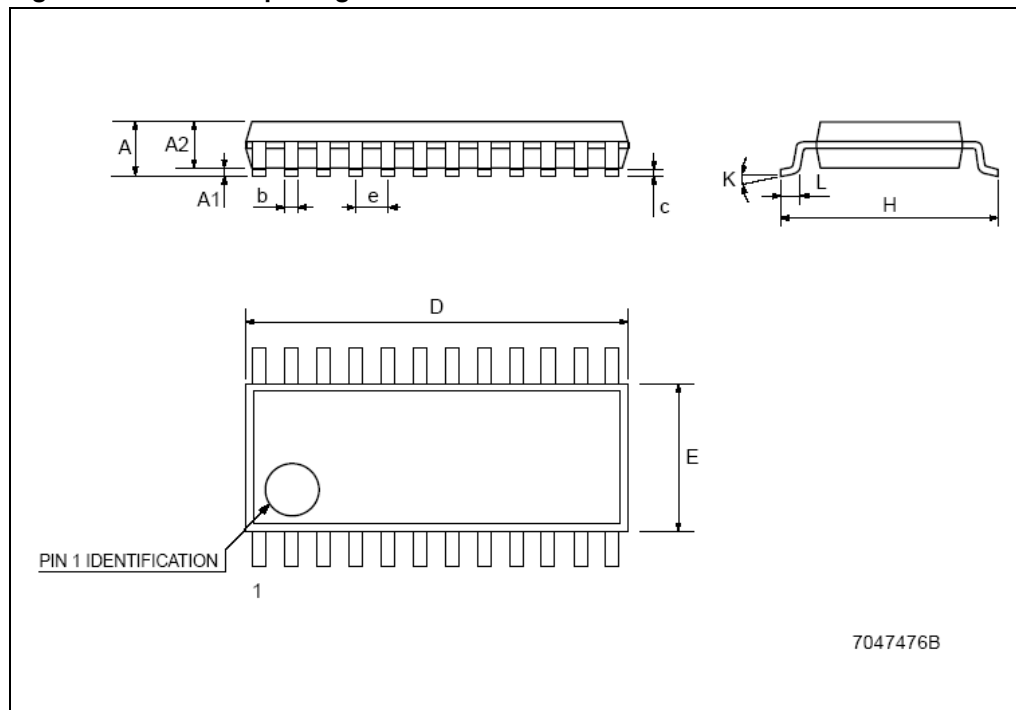

Table 16. Tape and reel TSSOP24

Dim.	mm.			inch		
	Min	Typ	Max	Min	Typ	Max
A			330			12.992
C	12.8		13.2	0.504		0.519
D	20.2			0.795		
N	60			2.362		
T			22.4			0.882
Ao	6.8		7	0.268		0.276
Bo	8.2		8.4	0.323		0.331
Ko	1.7		1.9	0.067		0.075
Po	3.9		4.1	0.153		0.161
P	11.9		12.1	0.468		0.476

Figure 23. Reel dimensions

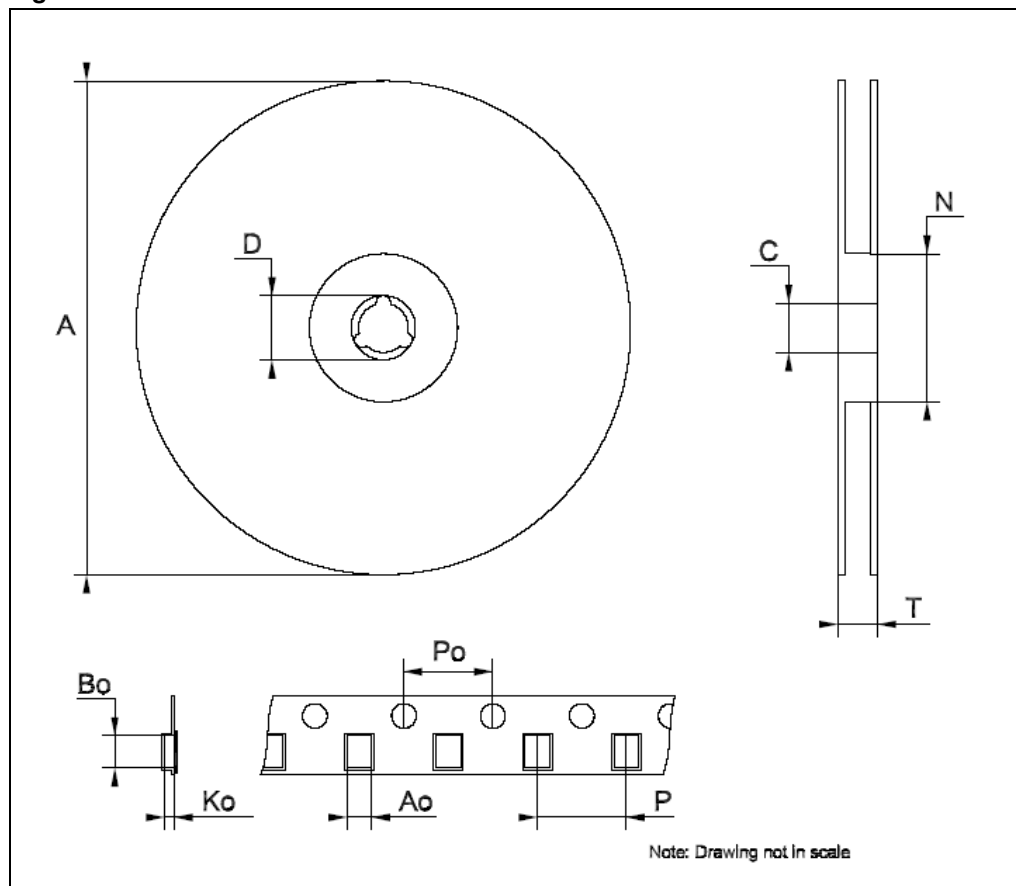

Table 17. SO-24 mechanical data

Dim.	mm.			inch		
	Min	Typ	Max	Min	Typ	Max
A			2.65			0.104
a1	0.1		0.2	0.004		0.008
a2			2.45			0.096
b	0.35		0.49	0.014		0.019
b1	0.23		0.32	0.009		0.012
C		0.5			0.020	
c1	45°(typ.)					
D	15.20		15.60	0.598		0.614
E	10.00		10.65	0.393		0.419
e		1.27			0.050	
e3		13.97			0.550	
F	7.40		7.60	0.291		0.300
L	0.50		1.27	0.020		0.050
S	°(max.) 8					

Figure 24. SO-24 package dimensions

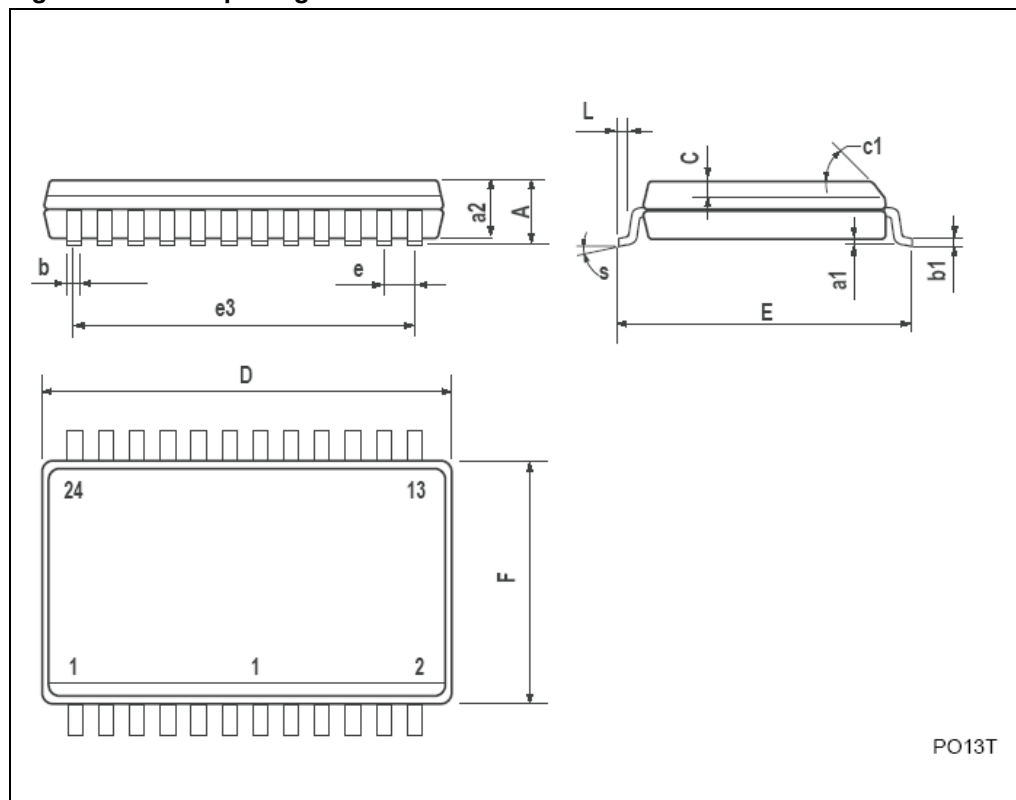

Table 18. Tape and reel SO-24

Dim.	mm.			inch		
	Min	Typ	Max	Min	Typ	Max
A			330			12.992
C	12.8		13.2	0.504		0.519
D	20.2			0.795		
N	60			2.362		
T			30.4			1.197
Ao	10.8		11.0	0.425		0.433
Bo	15.7		15.9	0.618		0.626
Ko	2.9		3.1	0.114		0.122
Po	3.9		4.1	0.153		0.161
P	11.9		12.1	0.468		0.476

Figure 25. Reel dimensions

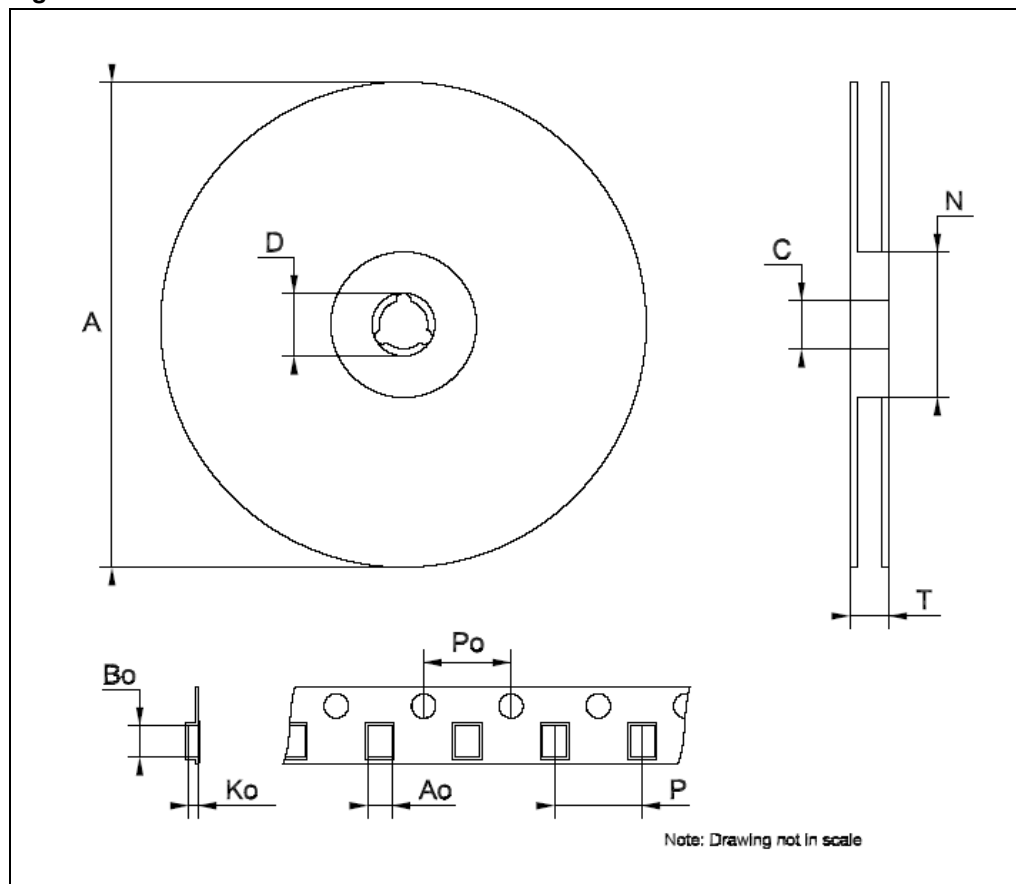
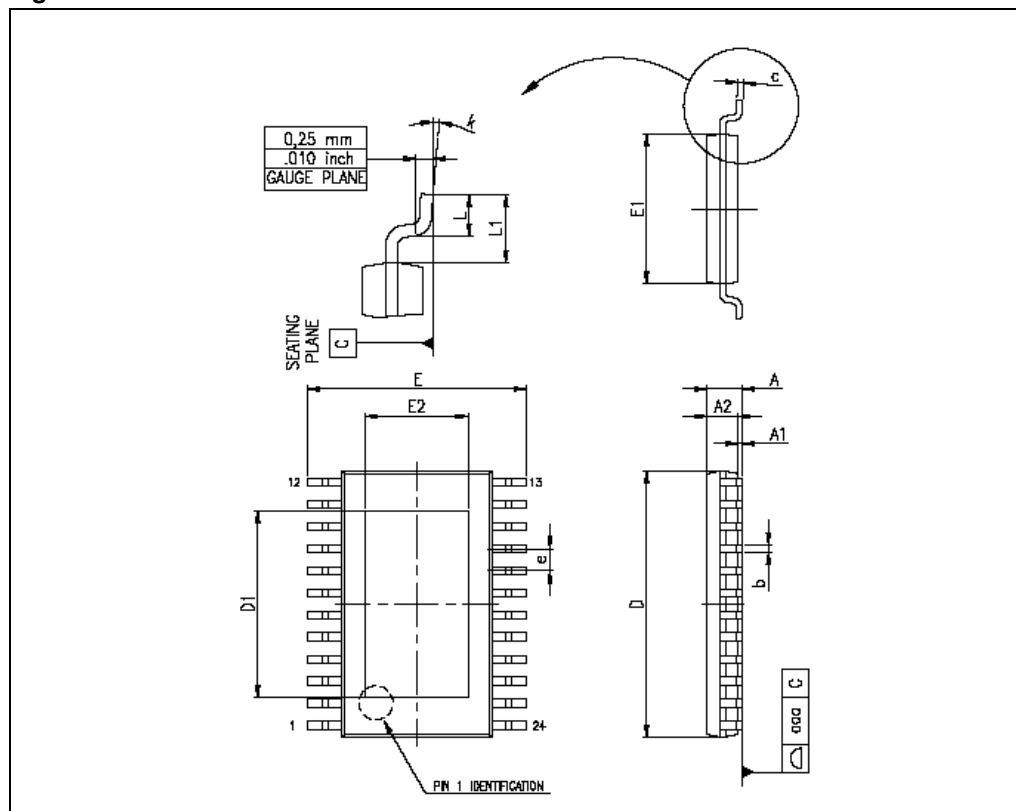

Table 19. TSSOP24 exposed pad

Dim.	mm			inch		
	Min	Typ	Max	Min	Typ	Max
A			1.2			0.047
A1			0.15		0.004	0.006
A2	0.8	1	1.05	0.031	0.039	0.041
b	0.19		0.30	0.007		0.012
c	0.09		0.20	0.004		0.0089
D	7.7	7.8	7.9	0.303	0.307	0.311
D1	4.7	5.0	5.3	0.185	0.197	0.209
E	6.2	6.4	6.6	0.244	0.252	0.260
E1	4.3	4.4	4.5	0.169	0.173	0.177
E2	2.9	3.2	3.5	0.114	0.126	0.138
e		0.65			0.0256	
K	0°		8°	0°		8°
L	0.45	0.60	0.75	0.018	0.024	0.030

Figure 26. TSSOP24 dimensions



9 Revision history

Table 20. Document revision history

Date	Revision	Changes
9-Jan-2007	1	First release
21-May-2007	2	Updated Table 7 on page 6
10-Jul-2007	3	Updated Table 9: Truth table on page 10
28-Feb-2008	4	Updated Table 15: TSSOP24 exposed-pad on page 23 Added QSOP-24 package information Table 14 and Figure 21 on page 22

Please Read Carefully:

Information in this document is provided solely in connection with ST products. STMicroelectronics NV and its subsidiaries ("ST") reserve the right to make changes, corrections, modifications or improvements, to this document, and the products and services described herein at any time, without notice.

All ST products are sold pursuant to ST's terms and conditions of sale.

Purchasers are solely responsible for the choice, selection and use of the ST products and services described herein, and ST assumes no liability whatsoever relating to the choice, selection or use of the ST products and services described herein.

No license, express or implied, by estoppel or otherwise, to any intellectual property rights is granted under this document. If any part of this document refers to any third party products or services it shall not be deemed a license grant by ST for the use of such third party products or services, or any intellectual property contained therein or considered as a warranty covering the use in any manner whatsoever of such third party products or services or any intellectual property contained therein.

UNLESS OTHERWISE SET FORTH IN ST'S TERMS AND CONDITIONS OF SALE ST DISCLAIMS ANY EXPRESS OR IMPLIED WARRANTY WITH RESPECT TO THE USE AND/OR SALE OF ST PRODUCTS INCLUDING WITHOUT LIMITATION IMPLIED WARRANTIES OF MERCHANTABILITY, FITNESS FOR A PARTICULAR PURPOSE (AND THEIR EQUIVALENTS UNDER THE LAWS OF ANY JURISDICTION), OR INFRINGEMENT OF ANY PATENT, COPYRIGHT OR OTHER INTELLECTUAL PROPERTY RIGHT.

UNLESS EXPRESSLY APPROVED IN WRITING BY AN AUTHORIZED ST REPRESENTATIVE, ST PRODUCTS ARE NOT RECOMMENDED, AUTHORIZED OR WARRANTED FOR USE IN MILITARY, AIR CRAFT, SPACE, LIFE SAVING, OR LIFE SUSTAINING APPLICATIONS, NOR IN PRODUCTS OR SYSTEMS WHERE FAILURE OR MALFUNCTION MAY RESULT IN PERSONAL INJURY, DEATH, OR SEVERE PROPERTY OR ENVIRONMENTAL DAMAGE. ST PRODUCTS WHICH ARE NOT SPECIFIED AS "AUTOMOTIVE GRADE" MAY ONLY BE USED IN AUTOMOTIVE APPLICATIONS AT USER'S OWN RISK.

Resale of ST products with provisions different from the statements and/or technical features set forth in this document shall immediately void any warranty granted by ST for the ST product or service described herein and shall not create or extend in any manner whatsoever, any liability of ST.

ST and the ST logo are trademarks or registered trademarks of ST in various countries.

Information in this document supersedes and replaces all information previously supplied.

The ST logo is a registered trademark of STMicroelectronics. All other names are the property of their respective owners.

© 2008 STMicroelectronics - All rights reserved

STMicroelectronics group of companies

Australia - Belgium - Brazil - Canada - China - Czech Republic - Finland - France - Germany - Hong Kong - India - Israel - Italy - Japan - Malaysia - Malta - Morocco - Singapore - Spain - Sweden - Switzerland - United Kingdom - United States of America

www.st.com

