

Differential Clock Buffer/Driver DDR400 and DDR333-Compliant

Features

- Supports 333-MHz and 400-MHz DDR SDRAM
- 60–273-MHz operating frequency
- Phase-locked loop (PLL) clock distribution for double data rate synchronous DRAM applications
- Distributes one clock input to six differential outputs
- External feedback pin FBIN is used to synchronize output to clock input
- Conforms to DDRI specification
- Spread Aware™ for electromagnetic interference (EMI) reduction
- 28-pin SSOP package

Description

This PLL clock buffer is designed for 2.6V_{DD} and 2.6AV_{DD} operation and differential output levels.

This device is a zero delay buffer that distributes a clock input CLKIN to six differential pairs of clock outputs (CLKT[0:5], CLKC[0:5]) and one feedback clock output FBOUT. The clock outputs are controlled by the input clock CLKIN and the feedback clock FBIN.

The two-line serial bus can set each output clock pair (CLKT[0:5], CLKC[0:5]) to the Hi-Z state. When AV_{DD} is grounded, the PLL is turned off and bypassed for test purposes.

The PLL in this device uses the input clock CLKIN and the feedback clock FBIN to provide high-performance, low-skew, low-jitter output differential clocks.

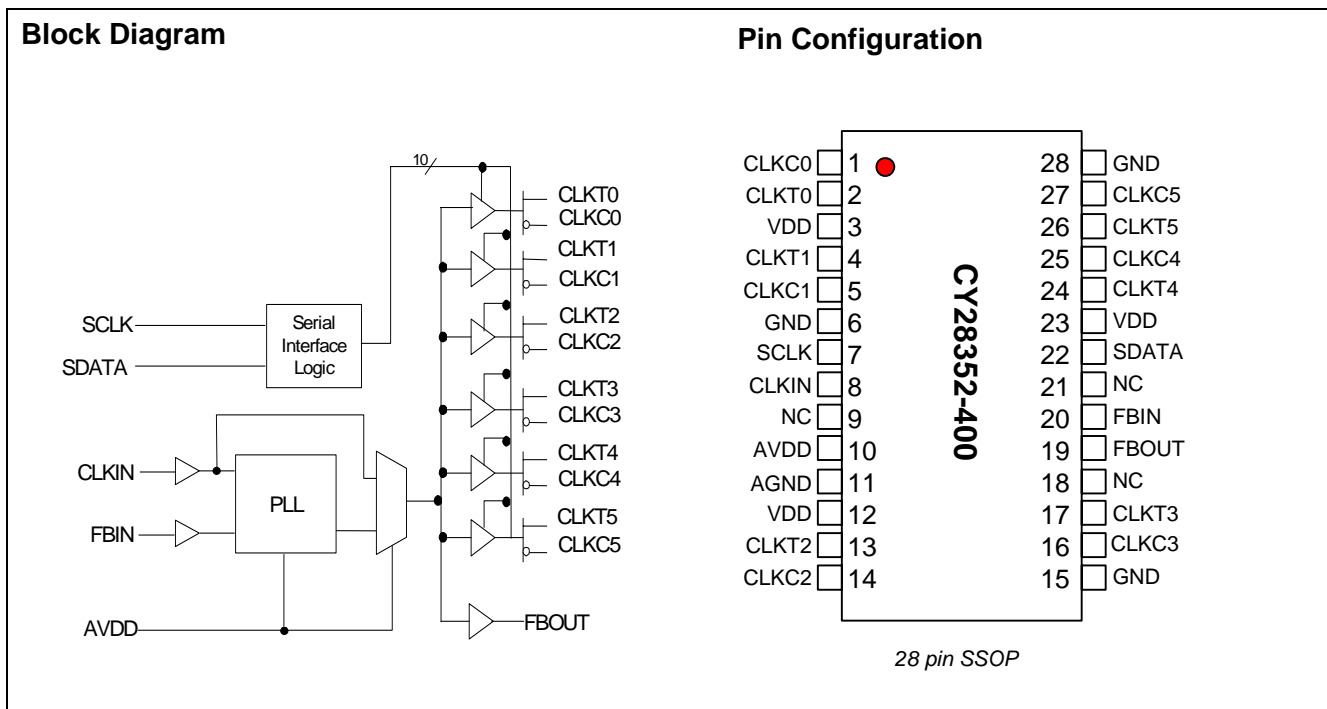

Pin Description^[1]

Pin Number	Pin Name	I/O	Pin Description	Electrical Characteristics
8	CLKIN	I	Complementary Clock Input.	Input
20	FBIN	I	Feedback Clock Input. Connect to FBOUT for accessing the PLL.	Input
2,4,13,17,24,26	CLKT(0:5)	O	Clock Outputs	Differential Outputs
1,5,14,16,25,27	CLKC(0:5)	O	Clock Outputs	
19	FBOUT	O	Feedback Clock Output. Connect to FBIN for normal operation. A bypass delay capacitor at this output will control Input Reference/Output Clocks phase relationships.	Output
7	SCLK	I	Serial Clock Input. Clocks data at SDATA into the internal register.	Data Input for the two line serial bus
22	SDATA	I/O	Serial Data Input. Input data is clocked to the internal register to enable/disable individual outputs. This provides flexibility in power management.	Data Input and Output for the two line serial bus
3,12,23	V _{DD}		2.6V Power Supply for Logic	2.6V Nominal
10	AV _{DD}		2.6V Power Supply for PLL	2.6V Nominal
6,15,28	GND		Ground	
11	AGND		Analog Ground for PLL	
9, 18, 21	NC		Not Connected	

Zero Delay Buffer

When used as a zero delay buffer the CY28352-400 will likely be in a nested clock tree application. For these applications the CY28352-400 offers a clock input as a PLL reference. The CY28352-400 can then lock onto the reference and translate with near zero delay to low-skew outputs. For normal operation, the external feedback input, FBIN, is connected to the feedback output, FBOUT. By connecting the feedback output to the feedback input the propagation delay through the device is eliminated. The PLL works to align the output edge with the input reference edge thus producing a near zero delay. The reference frequency affects the static phase offset of the PLL and thus the relative delay between the inputs and outputs.

When AV_{DD} is strapped LOW, the PLL is turned off and bypassed for test purposes.

Function Table

Inputs		Outputs			PLL
AVDD	CLKIN	CLKT(0:5) ^[2]	CLKC(0:5) ^[2]	FBOUT	
GND	L	L	H	L	BYPASSED/OFF
GND	H	H	L	H	BYPASSED/OFF
2.5V	L	L	H	L	On
2.5V	H	H	L	H	On
2.5V	<20 MHz	Hi-Z	Hi-Z	Hi-Z	Off

Notes:

1. A bypass capacitor (0.1µF) should be placed as close as possible to each positive power pin (< 0.2"). If these bypass capacitors are not close to the pins, their high-frequency filtering characteristic will be cancelled by the lead inductance of the traces.
2. Each output pair can be three-stated via the two-line serial interface.

Serial Control Registers

Following the acknowledge of the Address Byte, two additional bytes must be sent:

- Command Code byte
- Byte Count byte.

Byte0: Output Register1 (1 = Enable, 0 = Disable)

Bit	@Pup	Pin#	Description
7	1	2, 1	CLKT0, CLKC0
6	1	4, 5	CLKT1, CLKC1
5	1	–	Reserved
4	1	–	Reserved
3	1	13, 14	CLKT2, CLKC2
2	1	26, 27	CLKT5, CLKC5
1	1	–	Reserved
0	1	24, 25	CLKT4, CLKC4

Byte1: Output Register 2 (1 = Enable, 0 = Disable)

Bit	@Pup	Pin#	Description
7	1	–	Reserved
6	1	17, 16	CLKT3, CLKC3
5	0	–	Reserved
4	0	–	Reserved
3	0	–	Reserved
2	0	–	Reserved
1	0	–	Reserved
0	0	–	Reserved

Byte2: Test Register 3

Bit	@Pup	Pin#	Description
7	1	–	0 = PLL leakage test, 1 = disable test
6	1	–	Reserved
5	0	–	Reserved
4	0	–	Reserved
3	0	–	Reserved
2	0	–	Reserved
1	0	–	Reserved
0	0	–	Reserved

Absolute Maximum Conditions^[3]

Input Voltage Relative to V_{SS} : $V_{SS} - 0.3V$
 Input Voltage Relative to V_{DD} or AV_{DD} : $V_{DD} + 0.3V$
 Storage Temperature: $-65^{\circ}C$ to $+150^{\circ}C$
 Operating Temperature: $-40^{\circ}C$ to $+85^{\circ}C$
 Maximum Power Supply: $3.5V$

This device contains circuitry to protect the inputs against damage due to high static voltages or electric field; however, precautions should be taken to avoid application of any voltage higher than the maximum rated voltages to this circuit. For proper operation, V_{IN} and V_{OUT} should be constrained to the range:

$$V_{SS} < (V_{IN} \text{ or } V_{OUT}) < V_{DD}$$

Unused inputs must always be tied to an appropriate logic voltage level (either V_{SS} or V_{DD}).

DC Electrical Specifications^[4]

Parameter	Description	Condition	Min.	Typ.	Max.	Unit
V_{DD}, AV_{DD}	Supply Voltage	Operating	2.5	–	2.7	V
V_{IL}	Input Low Voltage	SDATA, SCLK	–	–	1.0	V
V_{IH}	Input High Voltage	SDATA, SCLK	2.2	–	–	V
V_{IL}	Input Voltage Low	CLKIN, FBIN	–	–	$0.3V_{DD}$	V
V_{IH}	Input Voltage High	CLKIN, FBIN	$0.6V_{DD}$	–	–	V
I_{IN}	Input Current	$V_{IN} = 0V$ or $V_{IN} = V_{DD}$, CLKIN, FBIN	–10	–	10	μA
V_{OL}	Output Low Voltage	$V_{DD} = 2.375V$, $I_{OL} = 12$ mA	–	–	0.6	V
V_{OH}	Output High Voltage	$V_{DD} = 2.375V$, $I_{OH} = -12$ mA	1.7	–	–	V
V_{OUT}	Output Voltage Swing ^[5]		1.1	–	$V_{DD} - 0.4$	V
V_{OC}	Output Crossing Voltage ^[6]		$(V_{DD}/2) - 0.15$	$V_{DD}/2$	$(V_{DD}/2) + 0.15$	V
I_{OZ}	High-Impedance Output Current	$V_O = GND$ or $V_O = V_{DD}$	–10	–	10	μA
I_{DDQ}	Dynamic Supply Current ^[7]	All V_{DD} , $FO = 273$ MHz	–	235	300	mA
I_{DSTAT}	Static Supply Current		–	–	1	mA
I_{DD}	PLL Supply Current	AV_{DD} only	–	9	12	mA
C_{IN}	Input Pin Capacitance		–	4	6	pF

AC Electrical Specifications^[7, 9]

Parameter	Description	Condition	Min.	Typ.	Max.	Unit
fCLK	Operating Clock Frequency	AV_{DD} , $V_{DD} = 2.5V$ to $2.7V$	60	–	273	MHz
tDC	Input Clock Duty Cycle		40	–	60	%
tlock	Maximum PLL lock Time		–	–	100	μs
D_{TYC}	Duty Cycle	60 MHz to 170 MHz	49	50	51	%
		170 MHz to 273 MHz	48	–	52	%
T_r / T_f	Output Clocks Slew Rate	20% to 80% of V_{OD}	1	–	2.5	V/ns
tpZL, tpZH	Output Enable Time ^[10] (all outputs)		–	3		ns
tpLZ, tpHZ	Output Disable Time ^[10] (all outputs)		–	3		ns

Notes:

- Multiple Supplies: The voltage on any input or I/O pin cannot exceed the power pin during power-up. Power supply sequencing is NOT required.
- Unused inputs must be held HIGH or LOW to prevent them from floating.
- For load conditions, see *Figure 7*.
- The value of V_{OC} is expected to be $|V_{TR} + VCPI|/2$. In case of each clock directly terminated by a 120Ω resistor. See *Figure 7*.
- All outputs switching loaded with 16 pF in 60Ω environment. See *Figure 7*.
- Parameters are guaranteed by design and characterization. Not 100% tested in production.
- PLL is capable of meeting the specified parameters while supporting SSC synthesizers with modulation frequency between 30 kHz and 33.3 kHz, with a down spread of -0.5% .
- Refers to transition of non-inverting output.
- All differential input and output terminals are terminated with $120\Omega/16$ pF as shown in *Figure 7*.
- Period Jitter and Half-Period Jitter specifications are separate, and must be met independently of each other.

AC Electrical Specifications(continued)^[7, 9]

Parameter	Description	Condition	Min.	Typ.	Max.	Unit
tCCJ	Cycle-to-Cycle Jitter ^[12]	f > 66 MHz	-75	-	75	ps
tjit(h-per)	Half-period jitter ^[12]	f > 66 MHz	-75	-	75	ps
tPLH	LOW-to-HIGH Propagation Delay, CLKIN to CLKT[0:5]		1.5	3.5	6	ns
tPHL	HIGH-to-LOW Propagation Delay, CLKIN to CLKT[0:5]		1.5	3.5	6	ns
tSKEW	Any Output to Any Output Skew ^[11]		-	-	100	ps
tPHASE	Phase Error ^[11]		-150	-	150	ps
tPHASEJ	Phase Error Jitter	f > 66 MHz	-50	-	50	ps

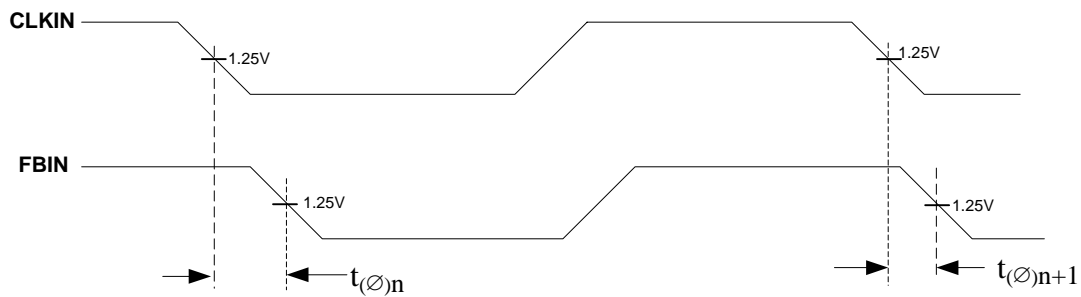
Parameter Measurement Information

$$t_{(\phi)n} = \frac{\sum_{1}^{n=N} t_{(\phi)n}}{N} \quad (N \text{ is large number of samples})$$

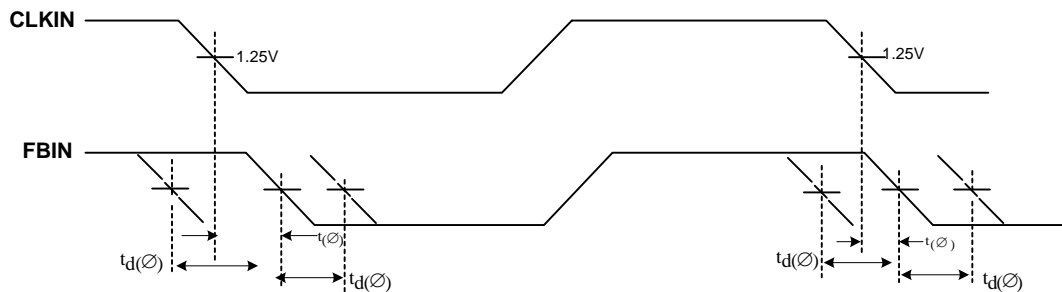
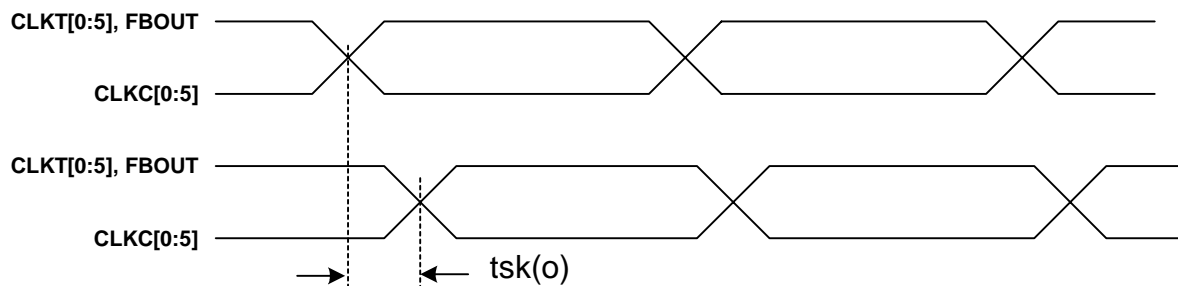
Figure 1. Static Phase Offset

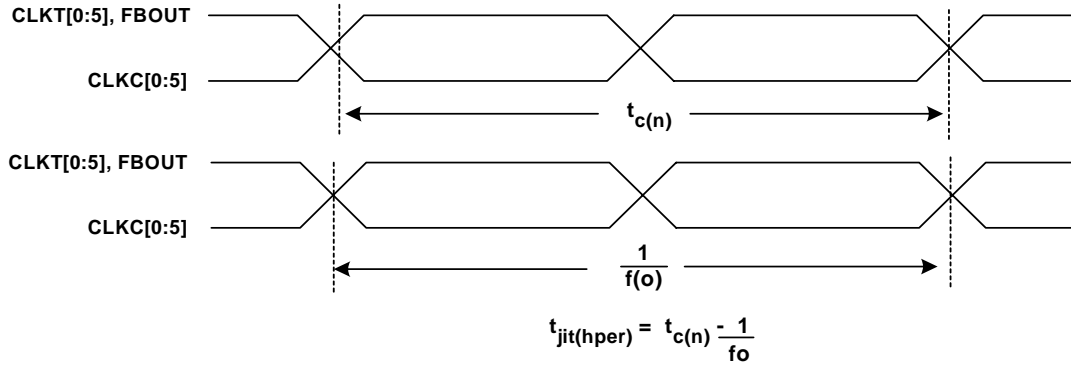
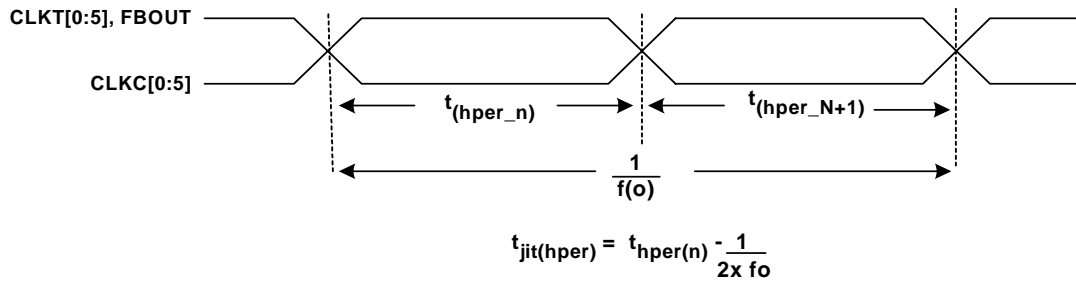
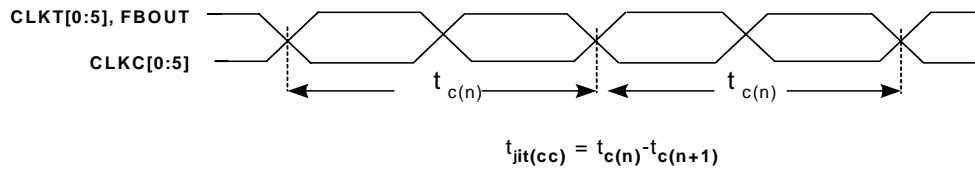
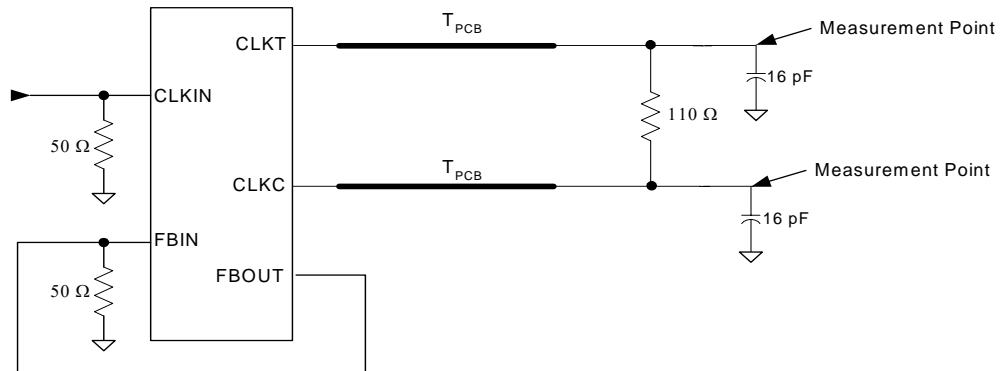
Figure 2. Dynamic Phase Offset

Figure 3. Output Skew

Figure 4. Period Jitter

Figure 5. Half-period Jitter

Figure 6. Cycle-to-Cycle Jitter

Figure 7. Differential Signal Using Direct Termination Resistor

