

ALL RIGHTS RESERVED. NO PORTION OF THIS PUBLICATION, WHETHER IN WHOLE OR IN PART CAN BE REPRODUCED WITHOUT THE EXPRESS WRITTEN CONSENT OF SPC TECHNOLOGY.

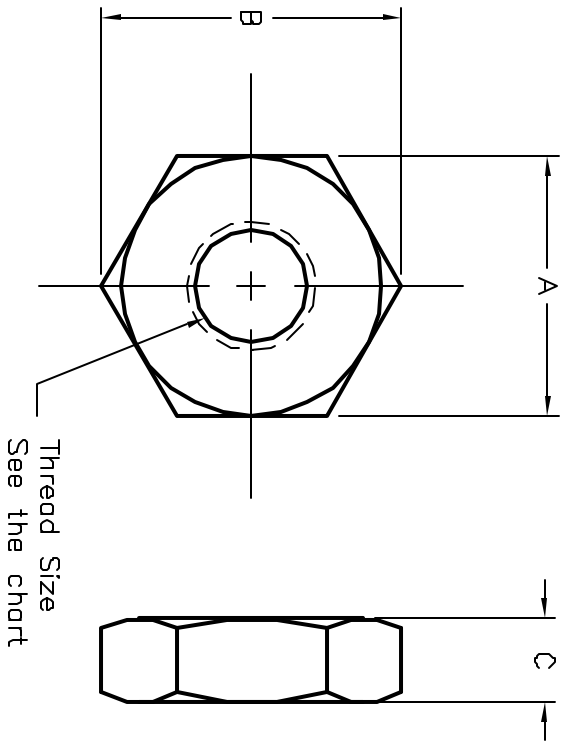

ROHS
Compliant

REVISIONS				DOC. NO.	SPC-FR005	Effective	12/21/08	Doc No	890
DOP #	REV	DESCRIPTION	DRAWN	DATE	CHECKED	DATE	APPRVD	DATE	
1950	A	RELEASED	JIN	10/22/08	JWM	10/22/08	JWM	10/22/08	



SPC Type No.	THREAD SIZE	A	B	C
SPC21805	2 - 56	.180 - .188	.205 - .217	.057 - .066
SPC21806	3 - 48	.180 - .188	.205 - .217	.057 - .066
SPC21801	4 - 40	.241 - .250	.275 - .289	.087 - .098
SPC21802	6 - 32	.241 - .250	.275 - .289	.087 - .098
SPC21807	6 - 32	.302 - .312	.344 - .361	.102 - .114
SPC21803	8 - 32	.241 - .250	.275 - .289	.087 - .098
SPC21808	8 - 32	.302 - .312	.344 - .361	.102 - .114
SPC21804	10 - 32	.362 - .375	.413 - .433	.117 - .130
SPC21809	1/4 - 20	.423 - .438	.482 - .505	.178 - .193

SPECIFICATIONS:

1. Material: Steel
2. Finish: Nickel plated

DISCLAIMER:
ALL STATEMENTS AND TECHNICAL INFORMATION CONTAINED HEREIN ARE BASED UPON INFORMATION AND/OR TESTS WE BELIEVE TO BE ACCURATE AND RELIABLE. SINCE CONDITIONS OF USE ARE BEYOND OUR CONTROL, THE USER SHALL DETERMINE THE SUITABILITY OF THE PRODUCT FOR THE INTENDED USE AND ASSUME ALL RISK AND LIABILITY WHATSOEVER IN CONNECTION THEREWITH.

UNLESS OTHERWISE SPECIFIED, DIMENSIONS ARE FOR REFERENCE PURPOSES ONLY.

DRAWN BY:	DATE:
Jason Nash	10/22/08
CHECKED BY:	DATE:
JWM	10/22/08
APPROVED BY:	DATE:
JWM	10/22/08



SPC TECHNOLOGY

DRAWING TITLE: **STEEL HEX NUT**

SIZE	DWG. NO.	ELECTRONIC FILE	REV
A	TA-967	TA-967.DWG	A
SCALE:	NTS	U.O.M.: INCHES	SHEET: 1 OF 1