



# 1812A/1812B/1813

CMOS IC

## SINGLE SOUND GENERATOR

### DESCRIPTION

The UTC **1812A/1812B/1813** is a CMOS LSI chip designed for use in sound effect products .It is equipped with tone circuit, noise circuit and other control logic to generate different sounds including rifle gun, machine gun, booming sound, door bell, alarm etc. The customer supplied sound source can be analyzed and programmed into an internal ROM by changing a mask layer during device fabrication. The UTC **1812A/1812B/1813** is suitable for various toy applications.

### FEATURES

- \*Single power supply: 2.4~3.3V
- \*Low standby current at 3V, 1μA typ
- \*Auto power-off function
- \*Speaker or direct piezo. application
- \*Built-in envelope control circuit
- \*1Hz-8Hz programmable LED flash output
- \*Minimum external components
- \*Low operating current
- \*Strong driving capability

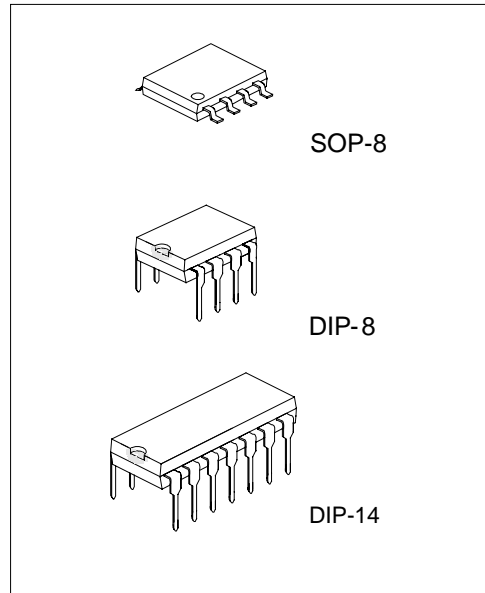

\*Pb-free plating product number:  
1812A/1812B/1813L

### ORDERING INFORMATION

Order Number		Package	Packing
Normal	Lead Free Plating		
1812A-D8-R	1812AL-D8-R	DIP-8	Tape Reel
1812A-D8-T	1812AL-D8-T	DIP-8	Tube
1812A-S8-R	1812AL-S8-R	SOP-8	Tape Reel
1812A-S8-T	1812AL-S8-T	SOP-8	Tube
1812B-D8-R	1812BL-D8-R	DIP-8	Tape Reel
1812B-D8-T	1812BL-D8-T	DIP-8	Tube
1812B-S8-R	1812BL-S8-R	SOP-8	Tape Reel
1812B-S8-T	1812BL-S8-T	SOP-8	Tube
1813-D14-T	1813L-D14-T	DIP-14	Tube

■ PIN CONFIGURATIONS

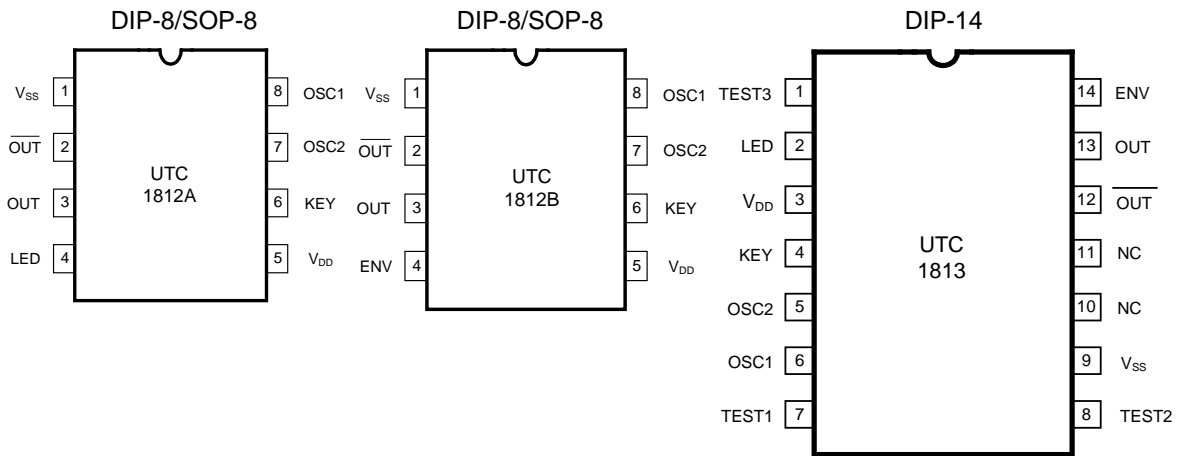

■ PIN CONFIGURATIONS

PIN NO.			SYMBOL	DESCRIPTION
1812A	1812B	1813		
1	1	9	V <sub>SS</sub>	Negative power supply, GND
2	2	12	$\overline{\text{OUT}}$	Sound output pad, out of phase to pad 3
3	3	13	OUT	Sound output pad
4	-	2	LED	LED flash output pad
-	4	14	ENV	Sound envelope control pad
5	5	3	V <sub>DD</sub>	Positive power supply
6	6	4	KEY	Key input pad, low active
7	7	5	OSC2	Oscillator output pad
8	8	6	OSC1	Oscillator input pad
-	-	7	TEST1	For IC test only
-	-	8	TEST2	For IC test only
-	-	1	TEST3	For IC test only
-	-	10,11	NC	No connection

■ BLOCK DIAGRAM

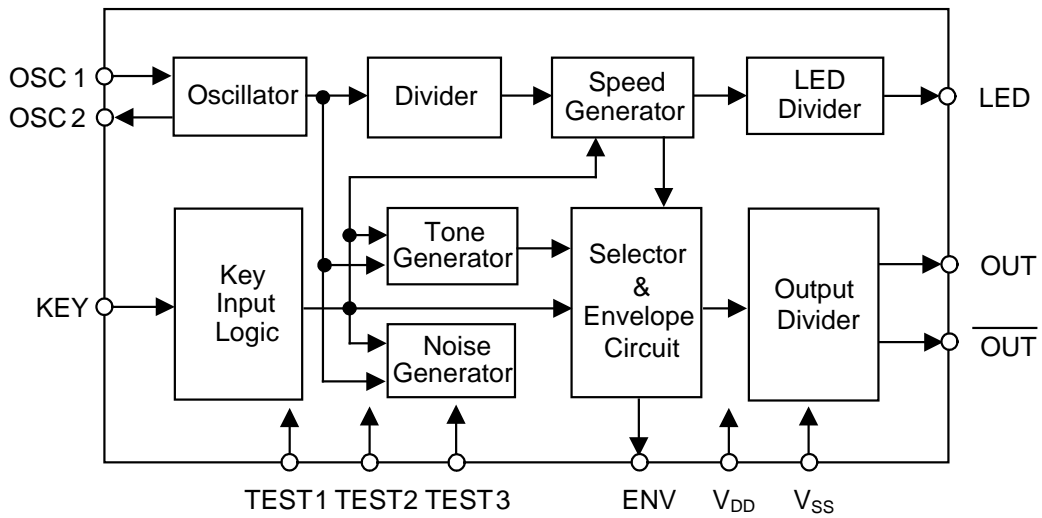

### ■ ABSOLUTE MAXIMUM RATINGS

PARAMETER	SYMBOL	VALUE	UNIT
Supply Voltage	$V_{CC}$	-0.3~5	V
Input Voltage	$V_{IN}$	$V_{SS}-0.3 \sim V_{DD}+0.3$	V
Operating Temperature	$T_{OPR}$	0~+70	°C
Storage Temperature	$T_{STG}$	-40~+150	°C

Note: 1. Absolute maximum ratings are those values beyond which the device could be permanently damaged.

Absolute maximum ratings are stress ratings only and functional device operation is not implied.

2. The device is guaranteed to meet performance specification within 0%~+70% operating temperature range and assured by design from -20%~+85%.

### ■ ELECTRICAL CHARACTERISTICS

PARAMETER	SYMBOL	TEST CONDITIONS	MIN	TYP	MAX	UNIT
Operating Voltage	$V_{DD}$	$V_{DD} = 3V$	2.4	3	3.3	V
"H" Input Voltage	$V_{IH}$	$V_{DD} = 3V$	2.4			V
"L" Input Voltage	$V_{IL}$	$V_{DD} = 3V$			0.6	V
Output Source Current	$I_{OH}$	$V_{DD} = 3V, V_{OH} = 2.5V$	-1	-2		mA
Output Sink Current	$I_{OL}$	$V_{DD} = 3V, V_{OL} = 0.5V$	1	2		mA
ENV Source Current	$I_{ENV}$	$V_{DD} = 3V, V_{OH} = 2.5V$	-1	-2		mA
LED Source Current	$I_{LED}$	$V_{DD} = 3V, V_{OH} = 2.5V$	-1	-2		mA
Standby Current	$I_{ST-BY}$	$V_{DD} = 3V$		1	5	$\mu A$
Operating Current	$I_{DD}$	$V_{DD} = 3V, NO\ LOAD$		300	600	$\mu A$
Oscillator Frequency	$F_{OSC}$	$R = 270k\Omega$		64		kHz

■ TIMING DIAGRAM

With an envelope

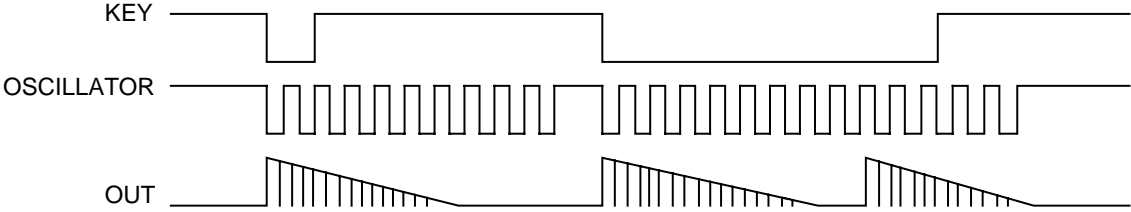

No envelope

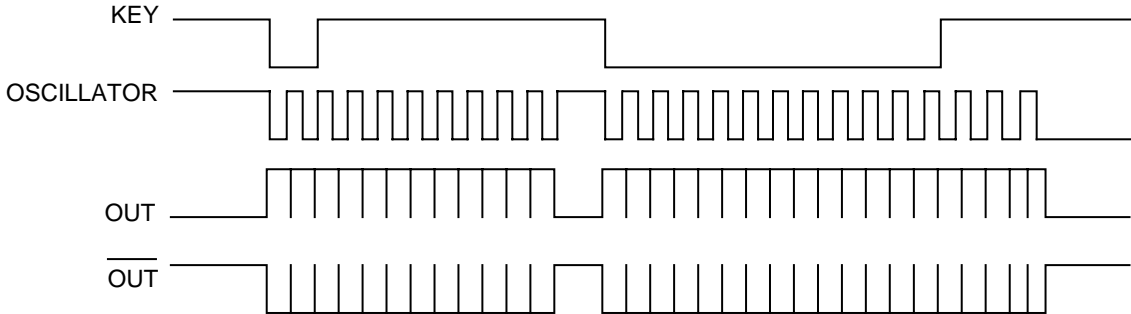

■ APPLICATION CIRCUITS

Speaker output with an envelope

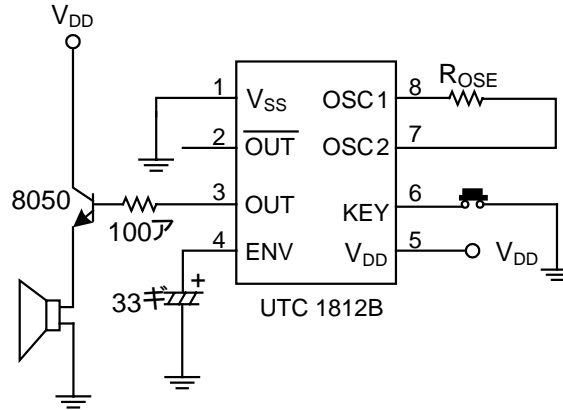

Speaker output without an envelope

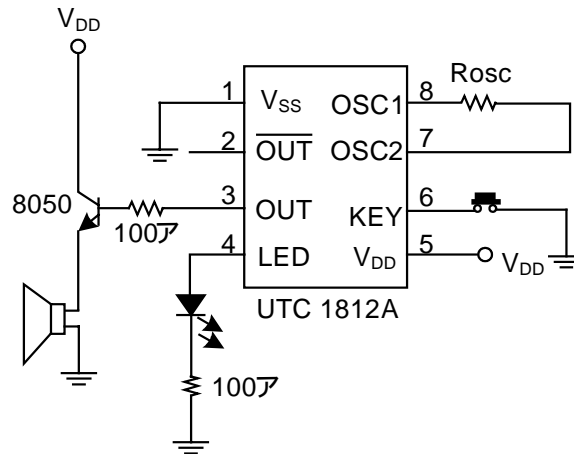

Piezo output without an envelope

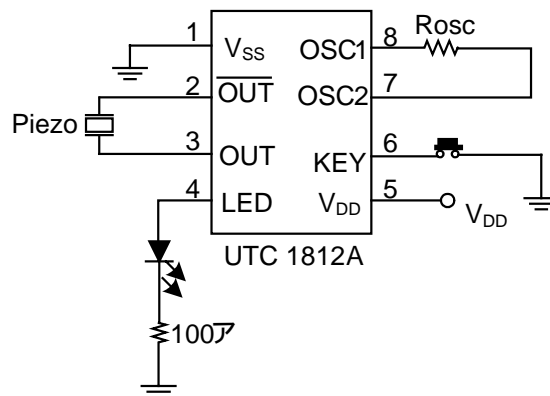

■ APPLICATION CIRCUITS(Cont.)

Hand touch trigger

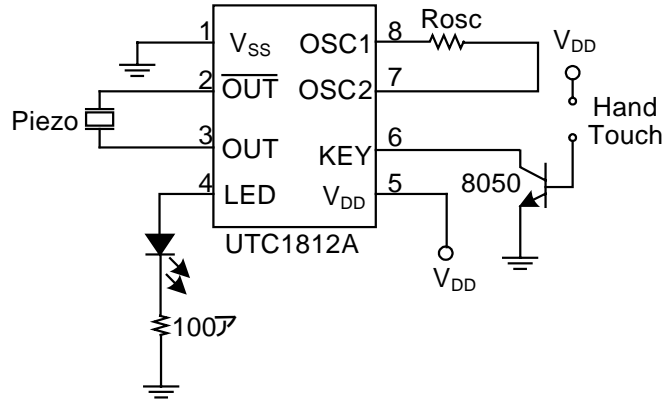

■ APPLICATION CIRCUITS (1812-SIREN I)

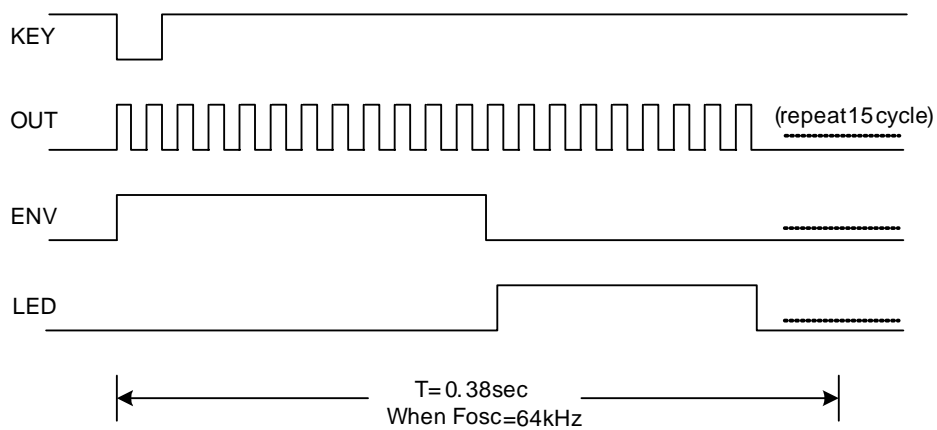
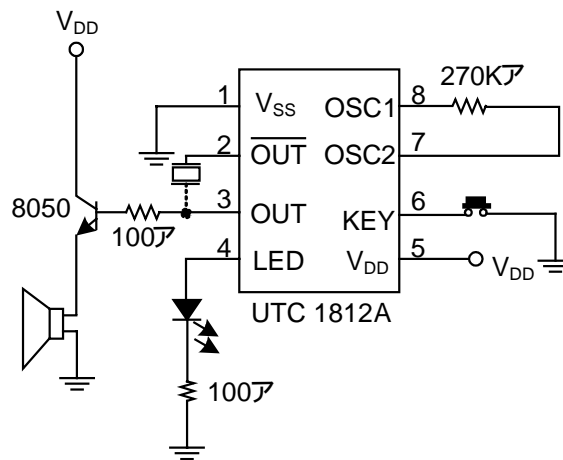

\* The IC substrate should be connected to  $V_{DD}$  in the PCB layout artwork

UTC assumes no responsibility for equipment failures that result from using products at values that exceed, even momentarily, rated values (such as maximum ratings, operating condition ranges, or other parameters) listed in products specifications of any and all UTC products described or contained herein. UTC products are not designed for use in life support appliances, devices or systems where malfunction of these products can be reasonably expected to result in personal injury. Reproduction in whole or in part is prohibited without the prior written consent of the copyright owner. The information presented in this document does not form part of any quotation or contract, is believed to be accurate and reliable and may be changed without notice.

