



# TBA820M

## LINEAR INTEGRATED CIRCUIT

### 1.2W AUDIO POWER AMPLIFIER

#### DESCRIPTION

The UTC **TBA820M** is a monolithic integrated audio amplifier. It is designed for audio frequency class b amplifier.

#### FEATURES

\*Wide operating supply voltage:  $V_{CC}=3\sim 14V$

\*Medium output power

$P_{OUT}=1.2W$  at  $V_{CC}=9V, R_L=8\Omega, THD=10\%$

\*Low quiescent circuit current:  $I_Q=4mA$ (type)

\*Good ripple rejection.

\*Minimum number of external parts required.

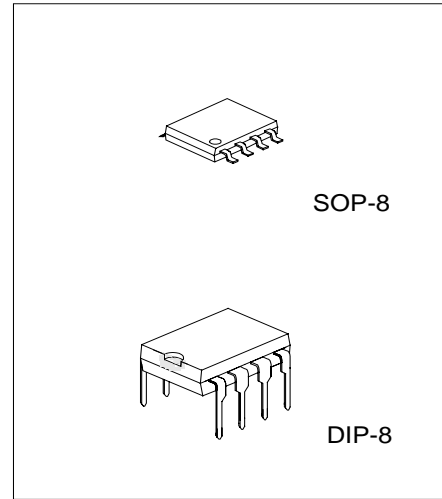

\*Pb-free plating product number: TBA820ML

#### ORDERING INFORMATION

Order Number		Package	Packing
Normal	Lead Free Plating		
TBA820M-S08-R	TBA820ML-S08-R	SOP-8	Tape Reel
TBA820M-S08-T	TBA820ML-S08-T	SOP-8	Tube
TBA820M-D08-T	TBA820ML-D08-T	DIP-8	Tube

#### BLOCK DIAGRAM

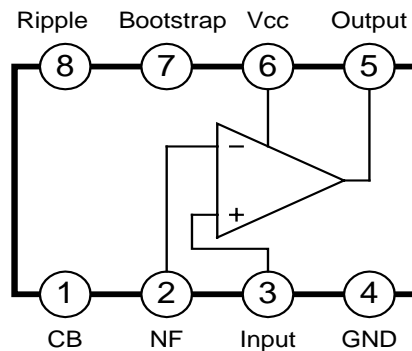

■ ABSOLUTE MAXIMUM RATINGS ( $T_a=25^\circ\text{C}$ )

PARAMETER	SYMBOL	RATINGS	UNIT
Supply Voltage	$V_{CC}$	16	V
Output Peak Current	$I_{O(\text{peak})}$	1.5	A
Power Dissipation	$P_D$	1.25	W
Operating Temperature	$T_{OPR}$	0 ~ +70	$^\circ\text{C}$
Storage Temperature	$T_{STG}$	-40 ~ +150	$^\circ\text{C}$

Note:1. Absolute maximum ratings are stress ratings only and functional device operation is not implied. The device could be damaged beyond Absolute maximum ratings.

2. The device is guaranteed to meet performance specifications within  $0^\circ\text{C}$ ~ $70^\circ\text{C}$  operating temperature range and assured by design from  $-20^\circ\text{C}$ ~ $85^\circ\text{C}$ .

■ ELECTRICAL CHARACTERISTICS

( $T_a=25^\circ\text{C}$ ,  $V_{CC}=9\text{V}$ ,  $F=1\text{KHZ}$ ,  $R_G=600\Omega$ ,  $R_F=120\Omega$ ,  $R_L=8\Omega$ , unless otherwise specified.)

PARAMETER	SYMBOL	TEST CONDITIONS	MIN	TYP	MAX	UNIT
Quiescent Current	$I_Q$	$V_{IN}=0$		4	12	mA
Output Power	$P_{OUT}$	$V_{CC}=9\text{V}, R_L=4\Omega, \text{THD}=10\%$		1.6		W
		$V_{CC}=9\text{V}, R_L=8\Omega, \text{THD}=10\%$	0.9	1.2		
		$V_{CC}=6\text{V}, R_L=4\Omega, \text{THD}=10\%$		0.75		
		$V_{CC}=6\text{V}, R_L=8\Omega, \text{THD}=10\%$	0.4	0.5		
		$V_{CC}=12\text{V}, R_L=8\Omega, \text{THD}=10\%$		2		
Total Harmonic Distortion	THD	$P_{OUT}=500\text{mW}$		0.3	1	%
Open Loop Voltage Gain	$G_{VO}$	$R_F=0$		75		dB
Closed Loop Voltage Gain	$G_{VC}$	$R_F=120\Omega$	33	36	39	dB
Input Resistance	$R_{IN}$			5		$\text{M}\Omega$
Output Noise Voltage	eN	$R_G=10\text{k}\Omega$ , $\text{BW}(-3\text{dB})=50\sim 20\text{kHz}$		0.3	1	mV

## ■ TEST CIRCUIT

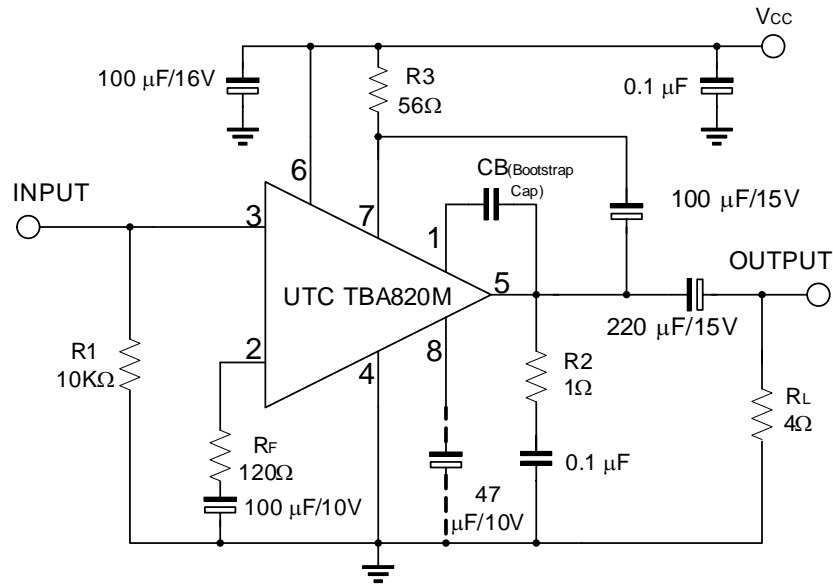

## ■ TYPICAL CHARACTERISTICS

Fig 1 Quiescent circuit current vs Supply Voltage

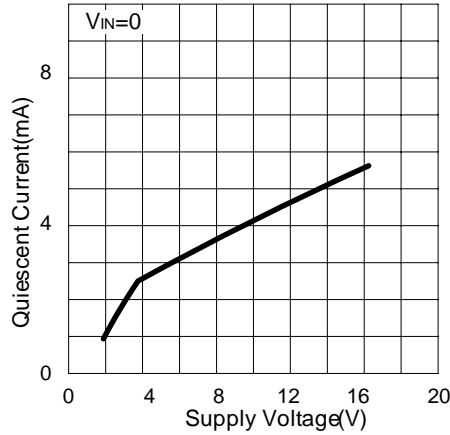

Fig 2 Output power vs Supply Voltage

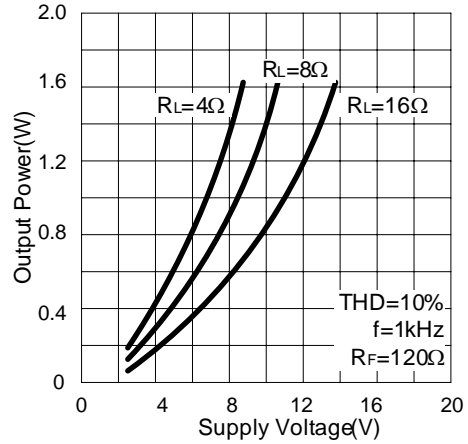

Fig 3 Total harmonic Distortion vs Output power

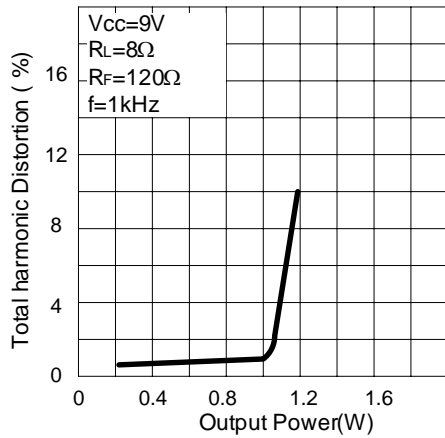

Fig 4 Voltage Gain vs Feedback resistance

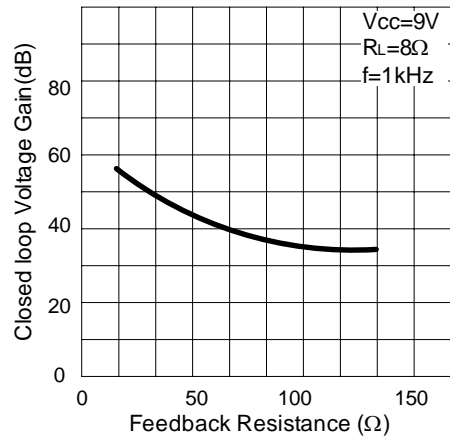

Fig 5 Power Dissipation vs Output power

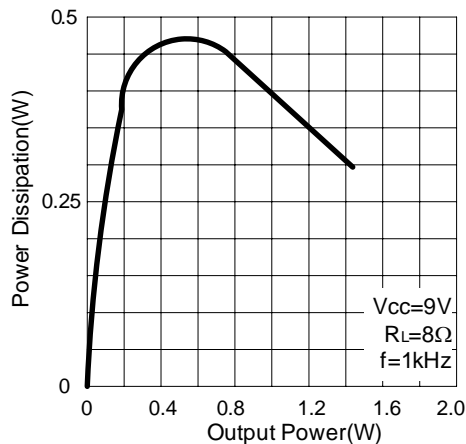
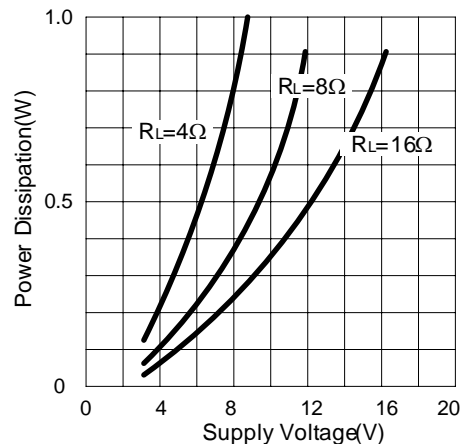

Fig 6 Power Dissipation vs Supply Voltage



### ■ TYPICAL CHARACTERISTICS(CONT.)

Fig 7 Frequency response

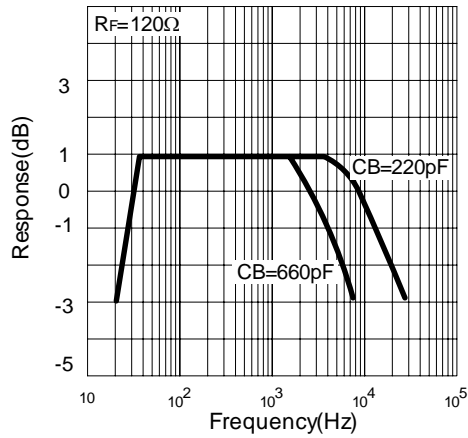
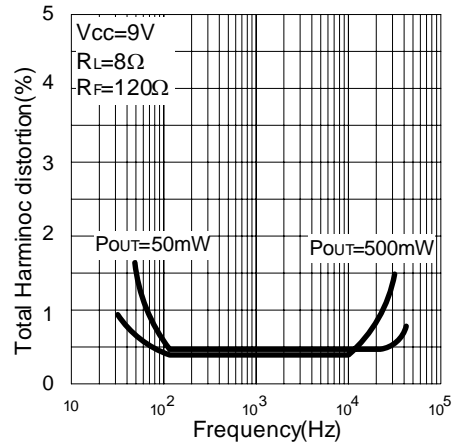

Fig 8 Total Harmonic distortion vs frequency



UTC assumes no responsibility for equipment failures that result from using products at values that exceed, even momentarily, rated values (such as maximum ratings, operating condition ranges, or other parameters) listed in products specifications of any and all UTC products described or contained herein. UTC products are not designed for use in life support appliances, devices or systems where malfunction of these products can be reasonably expected to result in personal injury. Reproduction in whole or in part is prohibited without the prior written consent of the copyright owner. The information presented in this document does not form part of any quotation or contract, is believed to be accurate and reliable and may be changed without notice.