

## 1/10th Unit Load RS-485 Transceiver

### FEATURES

- Allows Over 400 Transceivers On A Transmission Line (1/10th Unit Load)
- High Impedance on Receiver Inputs ( $R_{IN} = 150k\Omega$  typical)
- Half-Duplex Configuration Consistent With Industry Standard Pinout
- $-7V$  to  $+12V$  Common Mode Input Voltage Range
- Includes Shutdown Mode ( $I_{CC} < 10\mu A$ ) (For SP481R Only)
- Low Power Consumption (250mW)
- Separate Driver and Receiver Enable



*Now Available in Lead Free Packaging*

### DESCRIPTION

The **SP481R** and **SP485R** are pin-to-pin equivalent with our existing SP485 product and contain enhancements such as higher ESD tolerance and high receiver input impedance. The higher receiver input impedance allows for connecting over 400 transceivers on a single transmission line without degrading the RS-485 driver signal. Each device is packaged in an 8-pin plastic DIP or 8-pin narrow SOIC package. The **SP481R** offers a shutdown feature via the enable pins which will reduce the supply current ( $I_{CC}$ ) below  $0.5\mu A$  typical.

### TYPICAL APPLICATION CIRCUIT

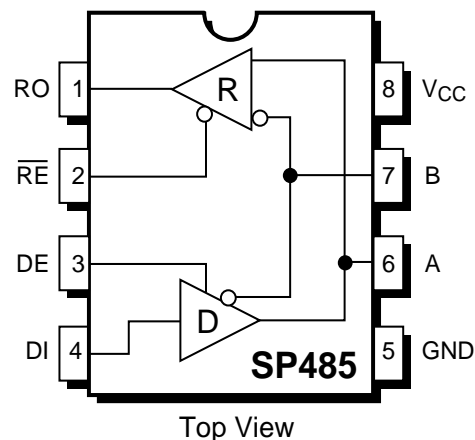

## ABSOLUTE MAXIMUM RATINGS

These are stress ratings only and functional operation of the device at these ratings or any other above those indicated in the operation sections of the specifications below is not implied. Exposure to absolute maximum rating conditions for extended periods of time may affect reliability.

$V_{CC}$ .....+7V  
 Storage Temperature.....-65°C to +150°C  
 Power Dissipation  
     8-pin Plastic DIP.....1000mW  
     8-pin Plastic N-SOIC.....1000mW

Package Derating:  
 8-pin Plastic DIP  
      $\theta_{JA}$ .....62°C/W  
 8-pin Plastic N-SOIC  
      $\theta_{JA}$ .....62°C/W

## ELECTRICAL CHARACTERISTICS

Typically 25°C @  $V_{CC} = +5V$  unless otherwise noted.

	MIN.	TYP.	MAX.	UNITS	CONDITIONS
<b>LOGIC INPUTS</b>					
$V_{IL}$			0.8	Volts	
$V_{IH}$	2.0			Volts	
<b>LOGIC OUTPUTS</b>					
$V_{OL}$			0.4	Volts	$I_{OUT} = -3.2mA$
$V_{OH}$	2.4			Volts	$I_{OUT} = 1.0mA$
<b>RS-485 DRIVER</b>					
<b>DC Characteristics</b>					
TTL Input Levels					
$V_{IL}$			0.8	Volts	
$V_{IH}$	2.0			Volts	
Outputs					
Open Circuit Voltage			6.0	Volts	
Differential Output	1.5		5.0	Volts	$R_L = 54\Omega, C_L = 50pF$
Balance			$\pm 0.2$	Volts	$ V_{T1}  -  V_{T1} $
Common-Mode Output			3.0	Volts	
Output Current	28.0			mA	$R_L = 54\Omega$
Short Circuit Current			$\pm 250$	mA	Terminated in -7V to +12V
<b>AC Characteristics</b>					
Maximum Data Rate	5			Mbps	$R_L = 54\Omega$
Output Transition Time		30		ns	Rise/fall time, 10%–90%
Propagation Delay					See Figures 3 and 5
$t_{PHL}$		60	100	ns	$R_{DIFF} = 54\Omega, C_{L1} = C_{L2} = 100pF$
$t_{PLH}$		60	100	ns	$R_{DIFF} = 54\Omega, C_{L1} = C_{L2} = 100pF$
Driver Output Skew		5	15	ns	see Figure 3 and 5, $t_{SKEW} =  t_{DPLH} - t_{DPHL} $
<b>RS-485 RECEIVER</b>					
<b>DC Characteristics</b>					
TTL Output Levels					
$V_{OL}$			0.4	Volts	
$V_{OH}$	2.4			Volts	
Tri-State Output Current			$\pm 1$	$\mu A$	$0.4V \leq V_{OUT} \leq 2.4V; \overline{RE} = V_{CC}$
Inputs					
Common Mode Range	-7.0		+12.0	Volts	$-7V \leq V_{CM} \leq +12V$
Receiver Sensitivity			$\pm 0.2$	Volts	$-7V \leq V_{CM} \leq +12V$
Input Impedance	120	150		k $\Omega$	

## ELECTRICAL CHARACTERISTICS

Typically 25°C @ V<sub>CC</sub> = +5V unless otherwise noted.

	MIN.	TYP.	MAX.	UNITS	CONDITIONS
<b>AC Characteristics</b>					
Maximum Data Rate	1			Mbps	
Propagation Delay					See Figures 3 and 7
$t_{PHL}$			1200	ns	$R_{DIFF}=54\Omega, C_{L1}=C_{L2}=100pF$
$t_{PLH}$			1200	ns	$R_{DIFF}=54\Omega, C_{L1}=C_{L2}=100pF$
Differential Receiver Skew		60		ns	$ t_{PLH} - t_{PHL} ; R_{DIFF}=54\Omega, C_{L1}=C_{L2}=100pF$ , see Figures 3 and 7
<b>SHUTDOWN TIMING (SP481R)</b>					
Time to Shutdown	50		600	ns	$\overline{RE} = V_{CC}, DE = 0V$
<b>RS-485 Driver</b>					
Enable Time					See Figures 4 and 6
Enable to Low		40	500	ns	$C_L=15pF, S_1$ Closed
Enable to High		40	500	ns	$C_L=15pF, S_2$ Closed
Disable Time					See Figures 4 and 6
Disable From Low		40	500	ns	$C_L=15pF, S_1$ Closed
Disable From High		40	500	ns	$C_L=15pF, S_2$ Closed
<b>RS-485 Receiver</b>					
Enable Time					See Figures 2 and 8
Enable to Low		40	500	ns	$C_L=15pF, S_1$ Closed
Enable to High		40	500	ns	$C_L=15pF, S_2$ Closed
Disable Time					See Figures 2 and 8
Disable From Low		40	500	ns	$C_L=15pF, S_1$ Closed
Disable From High		40	500	ns	$C_L=15pF, S_2$ Closed
<b>POWER REQUIREMENTS</b>					
Supply Voltage V <sub>CC</sub>	+4.75		+5.25	Volts	
Supply Current I <sub>CC</sub>					
No Load		300	500	μA	$\overline{RE} = V_{CC}$ or 0V, DE = 0V
No Load		500	900	μA	$\overline{RE} = V_{CC}$ or 0V, DE = V <sub>CC</sub>
Supply Current in Shutdown		0.5	10	μA	$\overline{RE} = V_{CC}, DE = 0V$
<b>ENVIRONMENTAL</b>					
Operating Temperature					
Commercial (..C..)	0		+70	°C	
Industrial (..E..)	-40		+85	°C	
Storage Temperature	-65		+150	°C	

## RECEIVER INPUT GRAPH

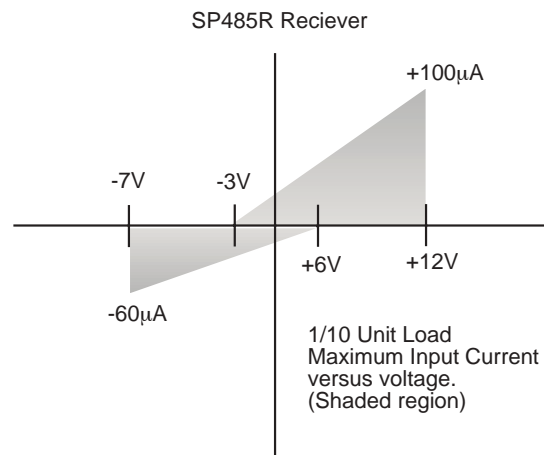
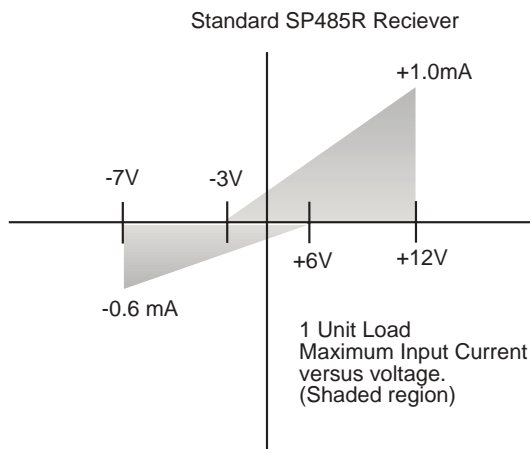

## TEST CIRCUITS

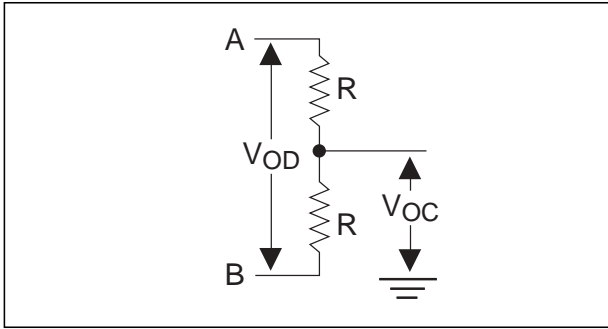

Figure 1. Driver DC Test Load Circuit

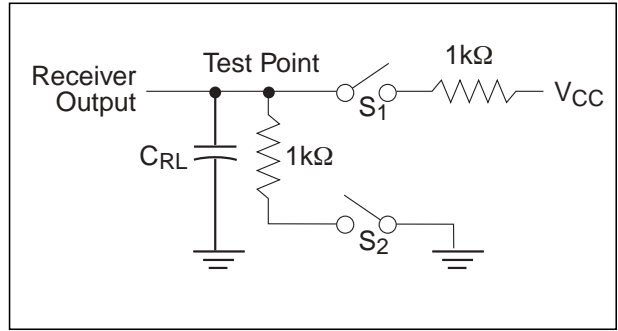

Figure 2. Receiver Timing Test Load Circuit

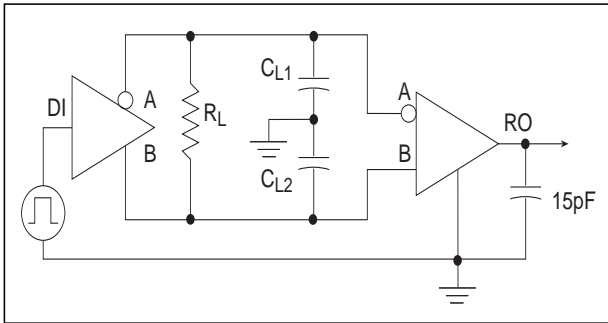

Figure 3. Driver/Receiver Timing Test Circuit

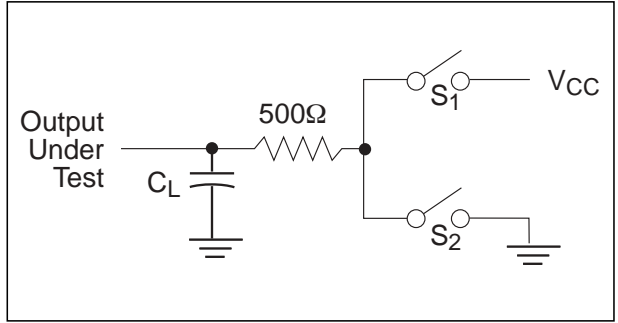

Figure 4. Driver Timing Test Load #2 Circuit

## SWITCHING WAVEFORMS

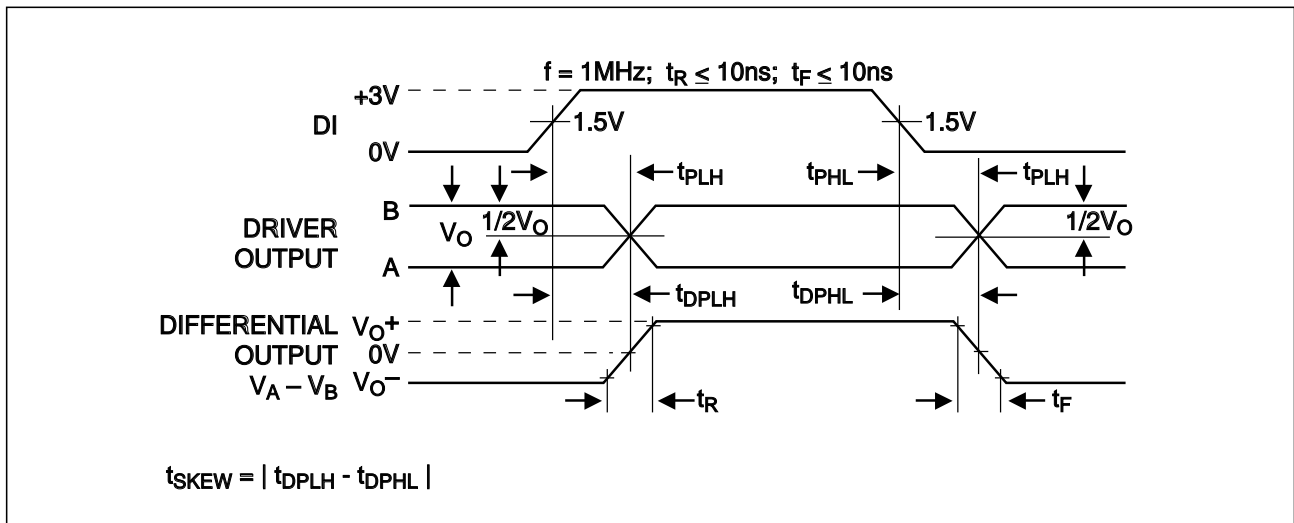

Figure 5. Driver Propagation Delays

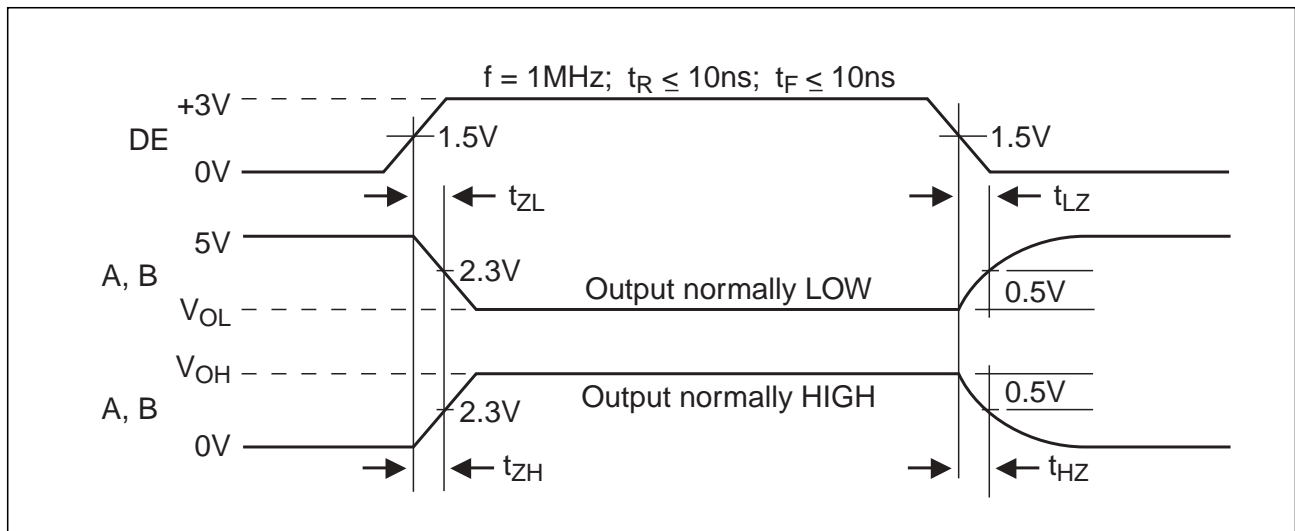

Figure 6. Driver Enable and Disable Times

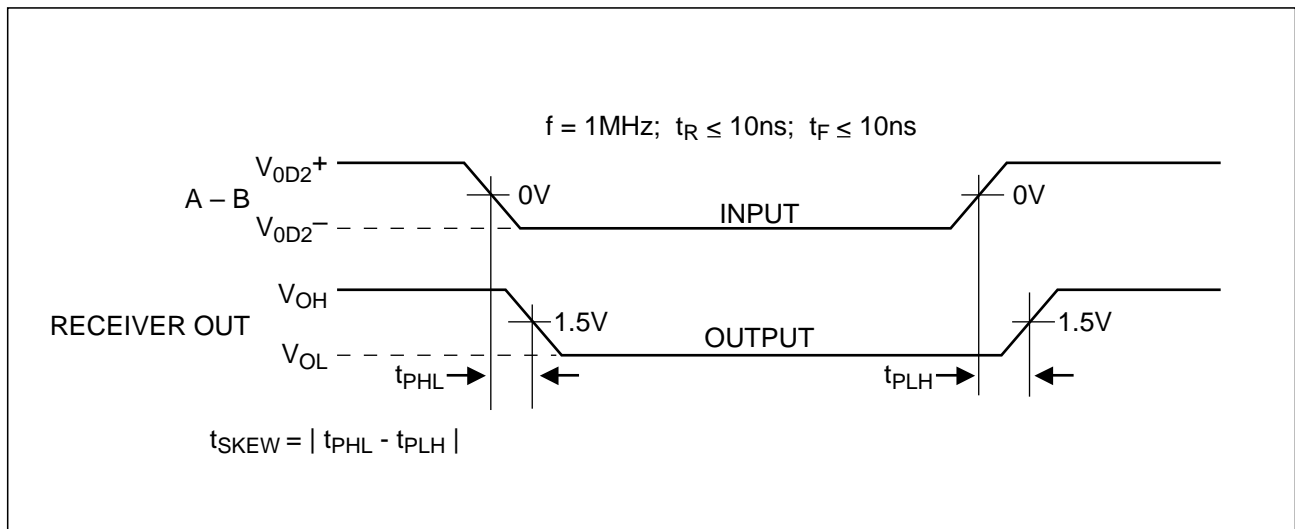

Figure 7. Receiver Propagation Delays

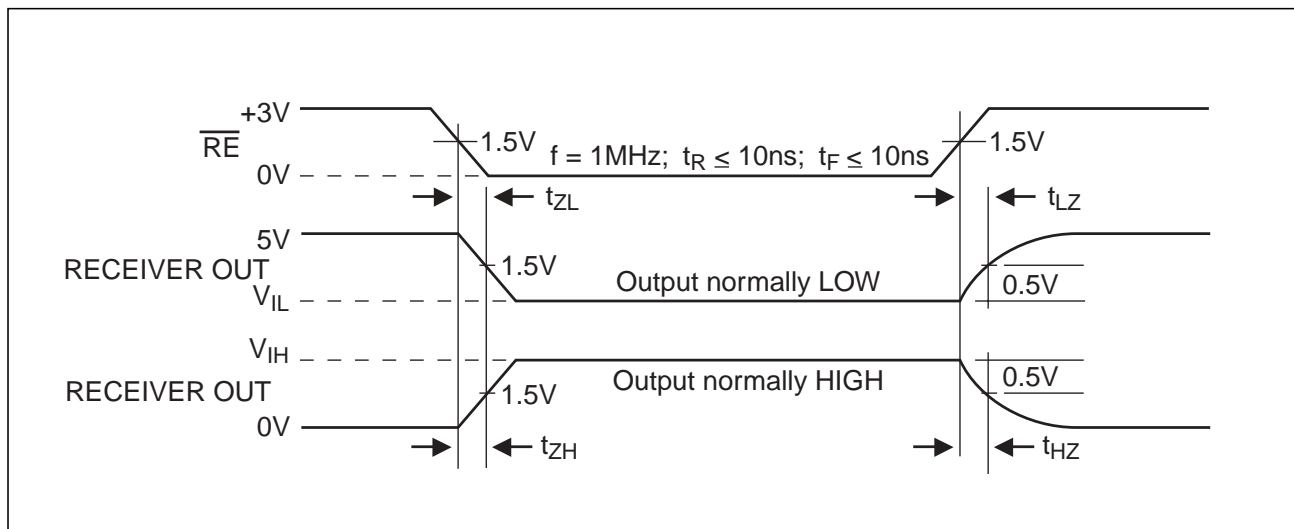

Figure 8. Receiver Enable and Disable Times

## GENERAL DESCRIPTION

The **SP485R** is a low power RS-485 differential transceiver. Similar to the SP485, the **SP485R** contains a half-duplex driver and receiver with tri-state control. However, the SP485R is intended for increased connections on a single bus compared to the original RS-485 specification.

The RS-485 standard is ideal for multi-drop applications where one bus can contain many drivers and/or receivers. The RS-485 standard implementation allows up to 32 transceivers to be connected on to the data bus. RS-485 is also specified for driving higher speeds over long cable lengths of up to 4,000 feet. The SP485R and SP481R exceed the standard by allowing up to 400 receivers to share a bus.

## DRIVERS

The driver output complies with the RS-485 electrical characteristics as specified by the standard. The output swings from 0V to  $V_{CC}$  and maintains greater than +1.5V with a  $54\Omega$  load attached between the two outputs. In adhering to the RS-485 specification, the driver outputs inherently comply with the RS-422 standard. With a load of  $100\Omega$  between the two outputs, the driver can sustain at least +2.0V.

The driver contains an enable pin (DE) which tri-states the output when DE is a logic LOW. The outputs during the tri-stated condition are at a high impedance ( $>100k\Omega$ ). A logic HIGH enables the driver for normal operation. The driver can operate to at least 5Mbps.

## RECEIVERS

The **SP485R** receiver has differential inputs with an input sensitivity of lower than  $\pm 200mV$ . As mentioned above, the RS-485 specification allows up to 32 transceivers on a the same bus. The **SP485R** allows over 400 transceivers on the same bus due to the high input impedance of at least  $120k\Omega$ . This higher capacity allows more components to be attached to the same bus without degrading the signal quality. The drivers are still able to drive an equivalent  $54\Omega$  from the 320 transceivers with an input impedance of at least  $120k\Omega$  in parallel along

with the two  $125\Omega$  cable termination resistors on each end.

The receiver contains an enable pin ( $\overline{RE}$ ) which enables the receiver when a logic LOW is asserted. A logic HIGH will tri-state the receiver output and the inputs will maintain at least  $120k\Omega$  impedance. The receiver can operate to at least 1Mbps.

The receiver also contains a fail-safe feature which outputs a logic HIGH when the inputs are open as in a disconnected cable.

## SHUTDOWN MODE

The **SP481R** includes a shutdown function to reduce power consumption. The shutdown is activated by simultaneously applying a logic LOW to DE and a logic HIGH to  $\overline{RE}$ . While in the shutdown mode, the power supply current is typically less than  $1\mu A$ . The driver outputs are disabled and are at a high impedance state determined by the receiver input impedance which should be at least  $120k\Omega$ . The receiver output is also at high impedance during shutdown. Output leakage current when the receiver is disabled is under  $1\mu A$ .

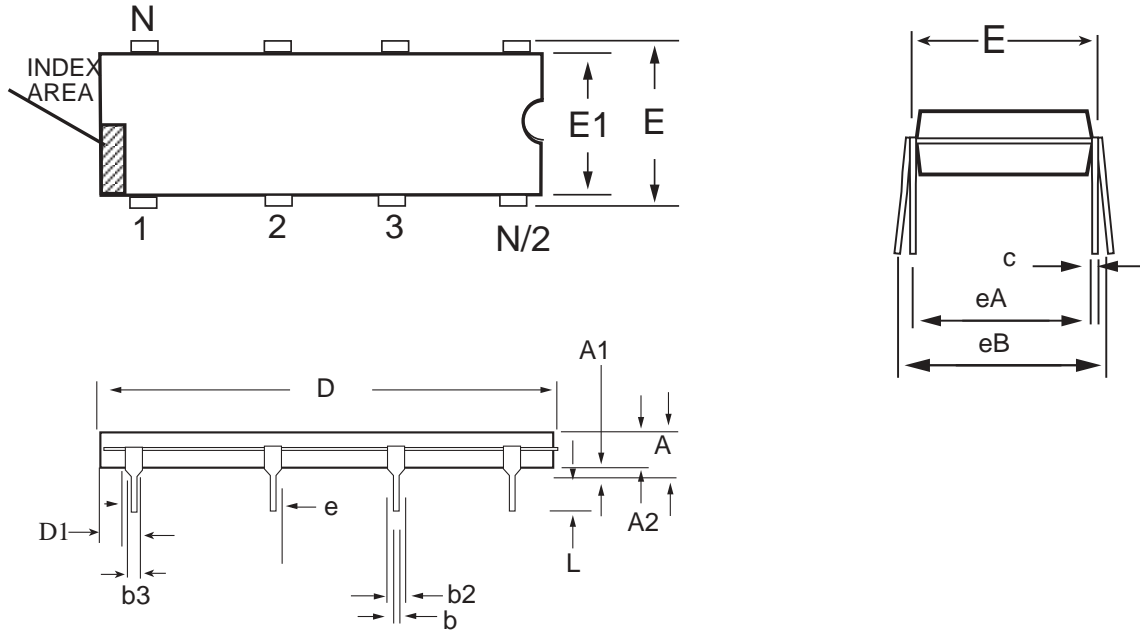

8 PIN PDIP JEDEC MS-001 (BA) Variation	Dimensions in inches		
	MIN	NOM	MAX
A	-	-	.210
A1	.015	-	-
A2	.115	.130	.195
b	.014	.018	.022
b2	.045	.060	.070
b3	.030	.039	.045
c	.008	.010	.014
D	.355	.365	.400
D1	.005	-	-
E	.300	.310	.325
E1	.240	.250	.280
e	.100 BSC		
eA	.300 BSC		
eB	-	-	.430
L	.115	.130	.150

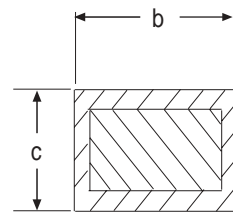

**8 PIN PDIP**

**PACKAGE: 8 PIN NSOIC**

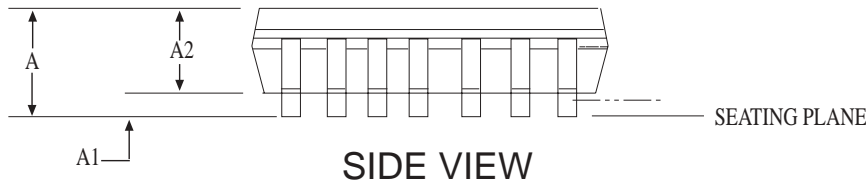
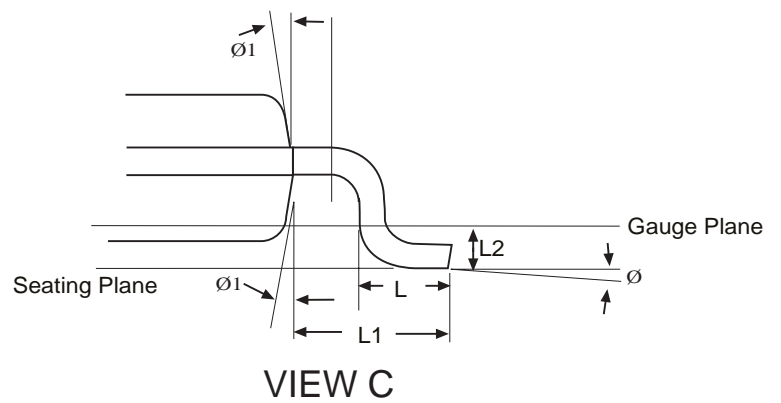
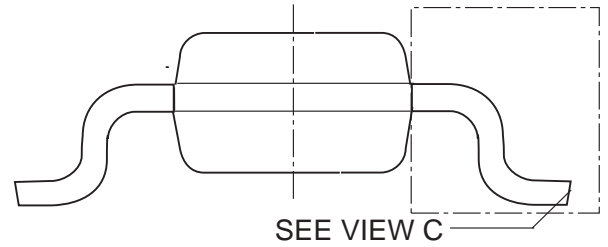
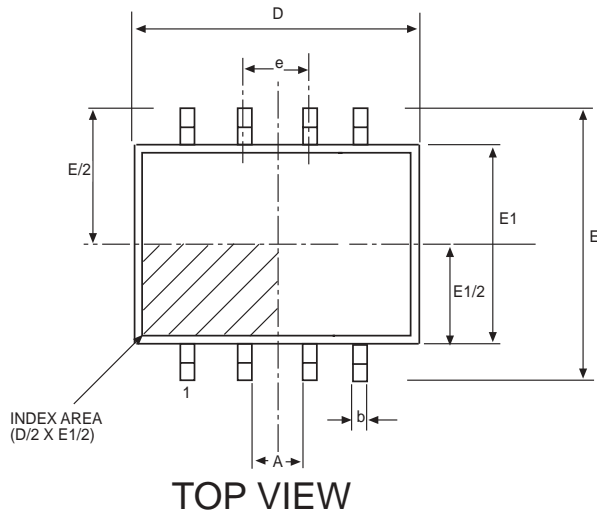

DIMENSIONS Minimum/Maximum (mm)	8 Pin NSOIC (JEDEC MS-012, AA - VARIATION)		
<b>COMMON HEIGHT DIMENSION</b>			
SYMBOL	MIN	NOM	MAX
A	1.35	-	1.75
A1	0.10	-	0.25
A2	1.25	-	1.65
b	0.31	-	0.51
c	0.17	-	0.25
D	4.90 BSC		
E	6.00 BSC		
E1	3.90 BSC		
e	1.27 BSC		
L	0.40	-	1.27
L1	1.04 REF		
L2	0.25 BSC		
Ø	0°	-	8°
Ø1	5°	-	15°

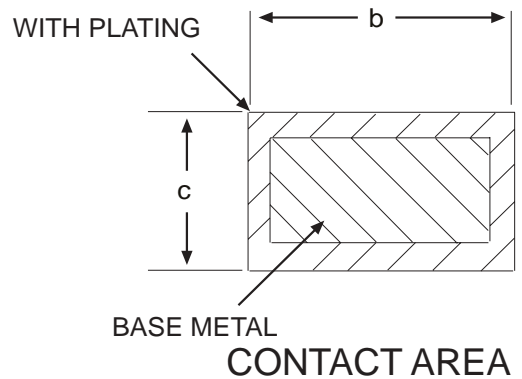

**PACKAGE: 8 PIN NSOIC**



## ORDERING INFORMATION

Part Number	Temperature Range	Package Types
SP481RCP .....	0°C to +70°C .....	8 Pin PDIP
SP481RCN .....	0°C to +70°C .....	8 Pin NSOIC
SP481RCN/TR .....	0°C to +70°C .....	8 Pin NSOIC
SP481REP .....	-40°C to +85°C .....	8 Pin PDIP
SP481REN .....	-40°C to +85°C .....	8 Pin NSOIC
SP481REN/TR .....	-40°C to +85°C .....	8 Pin NSOIC
SP485RCP .....	0°C to +70°C .....	8 Pin PDIP
SP485RCN .....	0°C to +70°C .....	8 Pin NOIC
SP485RCN/TR .....	0°C to +70°C .....	8 Pin NOIC
SP485REP .....	-40°C to +85°C .....	8 Pin PDIP
SP485REN .....	-40°C to +85°C .....	8 Pin NOIC
SP485REN/TR .....	-40°C to +85°C .....	8 Pin NOIC

Available in lead free packaging. To order add “-L” suffix to part number.

Example: SP485REN/TR = standard; SP485REN-L/TR = lead free

/TR = Tape and Reel

Pack quantity is 2,500 for NSOIC.

## REVISION HISTORY

DATE	REVISION	DESCRIPTION
6/21/04	A	Added extended temp range and tape and reel part numbers. Updated packaging specs.



ANALOG EXCELLENCE

**Sipex Corporation**

**Headquarters and  
Sales Office**  
233 South Hillview Drive  
Milpitas, CA 95035  
TEL: (408) 934-7500  
FAX: (408) 935-7600

Sipex Corporation reserves the right to make changes to any products described herein. Sipex does not assume any liability arising out of the application or use of any product or circuit described herein; neither does it convey any license under its patent rights nor the rights of others.