

Description

The Si4734/35 is the industry's first fully integrated, 100% CMOS AM/FM/SW/LW radio receiver IC. Offering unmatched integration and PCB space savings, the Si4734/35 requires minimal external components and less than 20 mm² of board area, excluding the antenna inputs. The Si4734/35 AM/FM/SW/LW radio provides the space savings and low power consumption necessary for portable devices while delivering the high performance and design simplicity desired for all AM/FM/SW/LW solutions.

Leveraging Silicon Laboratories' proven and patented Si4700/01 FM tuner's digital low intermediate frequency (low-IF) receiver architecture, the Si4734/35 delivers superior RF performance and interference rejection in AM, FM, and short wave and long wave bands. The high integration and complete system production test simplifies design-in, increases system quality, and improves manufacturability.

The Si4734/35 is a feature-rich solution including advanced seek algorithms, soft mute, auto-calibrated digital tuning, and FM stereo processing. In addition, the Si4734/35 provides analog or digital audio output and a programmable reference clock. The device supports I²C-compatible 2-wire control interface, SPI, and a Si4700/01 backwards-compatible 3-wire control interface.

The Si4734/35 utilizes digital processing to achieve high fidelity, optimal performance, and design flexibility. The chip provides excellent pilot rejection, selectivity, and unmatched audio performance, and offers both the manufacturer and the end-user extensive programmability and flexibility in the listening experience.

The Si4735 incorporates a digital processor for the European Radio Data System (RDS) and the North American Radio Broadcast Data System (RBDS), including all required symbol decoding, block synchronization, error detection, and error correction functions. Using RDS, the Si4735 enables broadcast data such as station identification and song name to be displayed to the user.

Features

- Worldwide FM band support (64–108 MHz)
- Worldwide AM band support(520–1710 kHz)
- SW band support (2.3–21.85 MHz)
- LW band support (153–279 KHz)
- Excellent real-world performance
- Freq synthesizer with integrated VCO
- Automatic frequency control (AFC)
- Automatic gain control (AGC)
- Integrated LDO regulator
- Digital FM stereo decoder
- Programmable de-emphasis
- Adaptive noise suppression
- AM/FM/SW/LW digital tuning
- No manual alignment necessary
- Adjustable channel filters
- EN55020 complaint
- Programmable reference clock
- Digital volume control
- Adjustable soft mute control
- RDS/RBDS processor (Si4735 only)
- Optional digital audio out (Si4735 only)
- 2-wire and 3-wire control interface
- 2.7 to 5.5 V supply voltage
- Wide range of ferrite loop sticks and air loop antennas supported
- 3 x 3 x 0.55 mm 20-pin QFN package
 - Pb-free/RoHS compliant

Applications

- Table and portable radios
- Stereos
- Mini/micro systems
- Portable media players
- Boomboxes
- Clock radios
- Modules
- Entertainment systems
- Cellular handsets

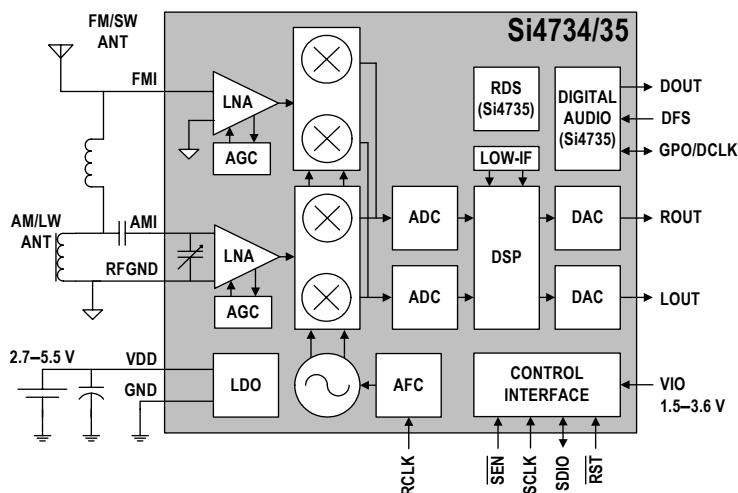

Selected FM Electrical Specifications

Parameter	Symbol	Test Condition	Min	Typ	Max	Unit
Input Frequency	f_{RF}		76	—	108	MHz
Sensitivity headphone matching		(S+N)/N = 26 dB	—	2.2	—	μ V EMF
Sensitivity 50 Ω matching		(S+N)/N = 26 dB	—	1.1	—	μ V EMF
Input IP3		$ f_2 - f_1 > 1$ MHz; $f_0 = 2 \times f_1 - f_2$	—	105	—	dB μ V EMF
Adjacent Channel Selectivity		± 200 kHz	—	50	—	dB
Alternate Channel Selectivity		± 400 kHz	—	70	—	dB
Audio Frequency Reponse Low		-3 dB	—	—	30	Hz
Audio Frequency Reponse High		-3 dB	15	—	—	kHz
Audio Mono S/N			—	63	—	dB
Audio THD			—	0.1	—	%
Audio Output Voltage			72	80	90	mVrms
Supply Voltage*	V_D, V_A		2.7	—	5.5	V
Interface Supply Voltage*	V_{IO}		1.5	—	3.6	V
Powerdown Current*	I_{PD}		—	10	—	μ A

***Note:** Applies to both FM and AM modes.

Selected AM/SW/LW Electrical Specifications

Parameter	Symbol	Test Condition	Min	Typ	Max	Unit
Input Frequency	f_{RF}	Medium wave (AM)	520	—	1710	kHz
		Short wave (SW)	2.3	—	21.85	MHz
		Long wave (LW)	153	—	279	kHz
Sensitivity		(S+N)/N = 26 dB	—	25	—	μ V EMF
Audio S/N			—	56	—	dB
Audio THD			—	0.1	—	%
Audio Output Voltage			54	60	66	mVrms

Pin Assignments

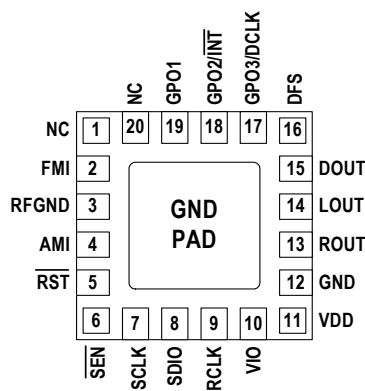

3 x 3 x 0.55 mm, 20-pin QFN Package Information

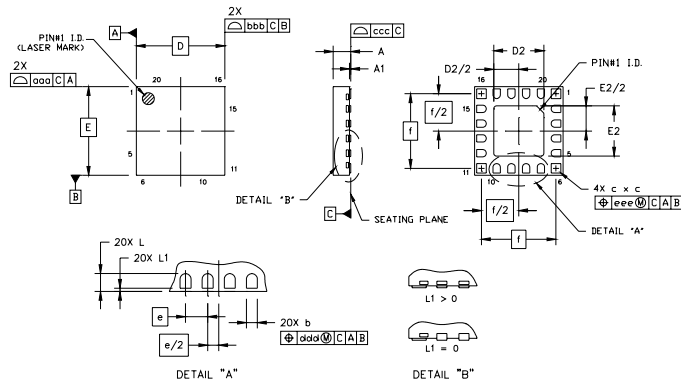

Symbol	Millimeters		
	Min	Nom	Max
A	0.50	0.55	0.60
A1	0.00	0.02	0.05
b	0.18	0.25	0.30
c	0.27	0.32	0.37
D	3.00 BSC		
D2	1.60	1.70	1.80
e	0.50 BSC		
E	3.00 BSC		
E2	1.60	1.70	1.80

Symbol	Millimeters		
	Min	Nom	Max
f	2.53 BSC		
L	0.35	0.40	0.45
L1	0.00	—	0.10
aaa	—	—	0.10
bbb	—	—	0.10
ccc	—	—	0.08
ddd	—	—	0.10
eee	—	—	0.10