

The value of  $f_0$  is shown in a separate table.  
Duty 50%

## Model Line-up

Model No.	B.P.F. frequency	Unit
GP1U78Q	40	kHz
GP1U780Q	36	
GP1U781Q	38	
GP1U782Q	36.7	
GP1U783Q	32.75	
GP1U787Q	56.8	

## Internal Block Diagram

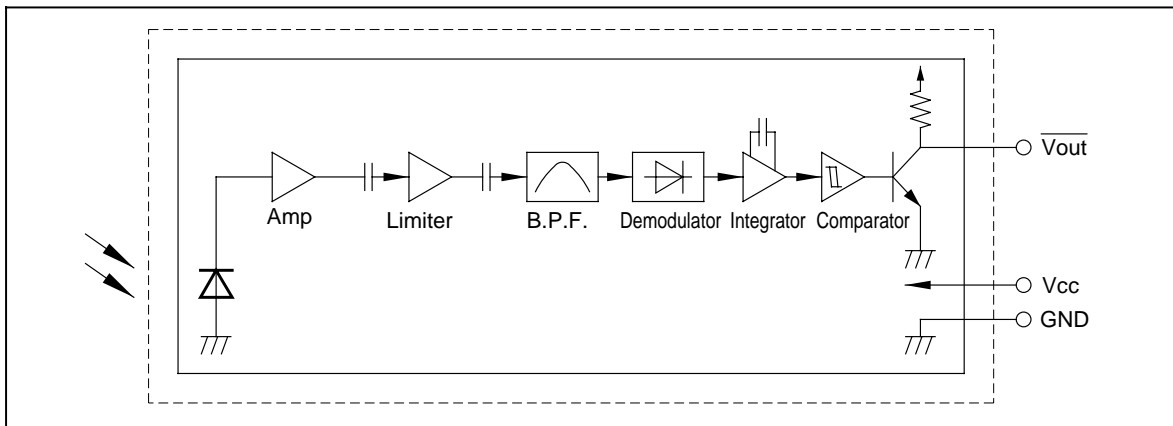

## ■ Performance

Using the transmitter shown in Fig. 1, the output signal of the light detecting unit is good enough to meet the following items in the standard optical system in Fig. 2.

### (1) Linear reception distance characteristics

When  $L = 0.2$  to  $6.5\text{m}$ ,  $E_e < 10\text{ lx}$  and  $\phi = 0^\circ$  in Fig. 2, the output signal shall meet the electrical characteristics in the attached list.

### (2) Sensitivity angle reception distance characteristics

When  $L = 0.2$  to  $4.5\text{m}$ ,  $E_e < 10\text{ lx}$  and  $\phi \leq 30^\circ$  in Fig. 2, the output signal shall meet the electrical characteristics in the attached list.

### (3) Anti outer peripheral light reception distance characteristics

When  $L = 0.2$  to  $3\text{m}$ ,  $E_e \leq 300\text{ lx}$  and  $\phi = 0^\circ$  in Fig. 2, the output signal shall meet the electrical characteristics in the attached list.

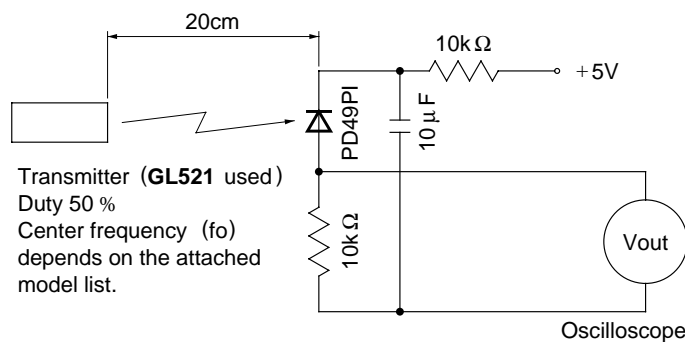

Fig. 1. Transmitter

In the above figure, the transmitter should be set so that the output  $V_{out}$  can be  $40\text{mV}_{PP}$ .

However, the **PD49PI** to be used here should be of the short-circuit current  $I_{sc} = 2.6\ \mu\text{A}$  at  $E_v = 100\text{ lx}$ .

( $E_v$  is an illuminance by CIE standard light source A (tungsten lamp).)

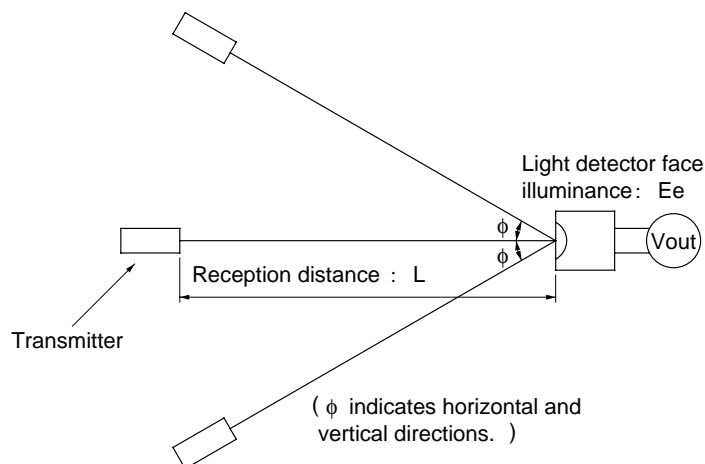

Fig. 2. Standard optical system

## ■ Precautions for Use

- (1) Use the light emitting unit (remote control transmitter), in consideration of performance, characteristics and operating condition of light emitting device and the characteristics of the light detecting unit.
- (2) Pay attention to a malfunction of the light detecting unit when the surface is stained with dust and refuse. Care must be taken not to touch the light detector surface. If it should be dirty, wipe off with soft cloth so as to prevent scratch. In case some solvents are required, use methyl alcohol, ethyl alcohol or isopropyl alcohol. Also, protect the light detecting unit against flux and others.
- (3) The shield case shall be grounded on PWB pattern.
- (4) Do not apply unnecessary force to the terminals and case from outside.
- (5) Do not push the light detector surface (photodiode) from outside.
- (6) To avoid the electrostatic breakdown of IC, handle the unit under the condition of grounding with human body, soldering iron, etc.
- (7) In case of adopting the infrared light detecting unit for the wireless remote control, use it in accordance with the transmission scheme and the signal format recommended in “Countermeasures for malfunction prevention of home appliances with infrared remote control” issued from Japan Association of Electrical Home Appliances (AEHA) in July 1987.
- (8) As for other general cautions, refer to the chapter “Precautions for Use” (Page 78 to 93).