

Type SCR Commutating Capacitors

Type SCRN Film-Paper/Extended Foil Commutating Capacitor



Type SCRN capacitors are for SCR (silicon controlled rectifier) commutating applications that require high peak and rms current capability. These capacitors are ideal for other high frequency and pulsed applications. The SCRN is supplied in oval or rectangular metal cases with 1/4 x 20 threaded stud and insulated terminals to withstand high current and high peak voltages.

Highlights

- Conforms to EIA RS401 for power semiconductor applications
- Non ferrous covers available for high frequency applications
- 40,000 hours life at full rated voltage and temperature
- High voltage, high current and high frequency

Specifications



Complies with the EU Directive 2002/95/EC requirement restricting the use of Lead (Pb), Mercury (Hg), Cadmium (Cd), Hexavalent chromium (Cr(VI)), PolyBrominated Biphenyls (PBB) and PolyBrominated Diphenyl Ethers (PBDE).

Capacitance Range: 0.25 μ F to 50.0 μ F

Voltage Range: 200 Vpk to 2000 Vpk

Capacitance Tolerance: \pm 10%

Temperature Range: -40 $^{\circ}$ C to $+65$ $^{\circ}$ C

Surface Temperature: $+80$ $^{\circ}$ C

Ratings

Cap (μ F)	Catalog Part Number	Case Code	H (In.)	Max VA (65 $^{\circ}$ C)	Max (Arms)
200 Vpk (Paper Dielectric)					
3	SCRN201R-F	A	2.13	400	60
5	SCRN202R-F	A	2.63	465	60
10	SCRN203R-F	A	3.88	625	60
15	SCRN205R-F	A	4.75	765	60
20	SCRN206R-F	B	4.25	875	60
30	SCRN208R-F	C	5.25	1200	60
40	SCRN209R-F	C	6.75	1500	60
50	SCRN210R-F	D	5.75	1590	60
400 Vpk (Film and Paper Dielectric)					
2	SCRN211R-F	A	2.63	790	60
3	SCRN212R-F	A	2.63	970	60
5	SCRN213R-F	A	3.88	1130	60
10	SCRN214R-F	B	4.75	1930	60
15	SCRN215R-F	C	4.75	2240	60
20	SCRN216R-F	C	6.25	2800	60
30	SCRN217R-F	D	6.75	3720	60
40	SCRN218R-F	D	8.00	4330	60
50	SCRN219R-F	E	6.25	6050	100
600 Vpk (Film and Paper Dielectric)					
2	SCRN220R-F	A	2.63	815	60
3	SCRN221R-F	A	3.13	1200	60
5	SCRN222R-F	A	4.25	1420	60
10	SCRN224R-F	C	4.25	2040	60
15	SCRN226R-F	C	5.75	2800	60
20	SCRN227R-F	D	5.75	3260	60
25	SCRN229R-F	D	6.75	3720	60
30	SCRN230R-F	D	8.00	4330	60
40	SCRN231R-F	E	6.25	6060	100
50	SCRN232R-F	E	7.25	6850	100

Cap (μ F)	Catalog Part Number	Case Code	H (In.)	Max VA (65 $^{\circ}$ C)	Max (Arms)
600 Vpk (Film Dielectric for Low-loss)					
1	SCRN262R-F	A	2.38	2200	60
2	SCRN263R-F	A	2.38	2060	60
3	SCRN264R-F	A	3.88	3190	60
5	SCRN265R-F	A	4.25	4380	60
10	SCRN266R-F	C	4.25	6060	60
1000 Vpk (Film and Paper Dielectric)					
1	SCRN233R-F	A	2.13	790	60
2	SCRN234R-F	A	3.13	1070	60
3	SCRN235R-F	A	3.88	1455	60
5	SCRN236R-F	B	4.25	1785	60
10	SCRN237R-F	C	5.75	2570	60
15	SCRN238R-F	D	5.75	3170	60
20	SCRN239R-F	E	5.13	5200	100
1500 Vpk (Film and Paper Dielectric)					
.5	SCRN240R-F	A	2.13	990	60
1	SCRN241R-F	A	2.88	1240	60
2	SCRN242R-F	B	3.50	1890	60
3	SCRN243R-F	C	4.25	2550	60
5	SCRN244R-F	C	5.75	3250	60
10	SCRN245R-F	E	5.13	6500	100
2000 Vpk (Film and Paper Dielectric)					
.25	SCRN246R-F	A	2.13	990	60
.33	SCRN257R-F	A	2.13	1000	60
.5	SCRN247R-F	A	2.63	1180	60
1	SCRN248R-F	A	3.13	1300	60
2	SCRN249R-F	B	4.25	2230	60
3	SCRN251R-F	C	4.75	2800	60
5	SCRN253R-F	D	5.75	4020	60
10	SCRN256R-F	F	5.75	7600	100

Type SCR Commutating Capacitors

Outline Drawings

RoHS Compliant

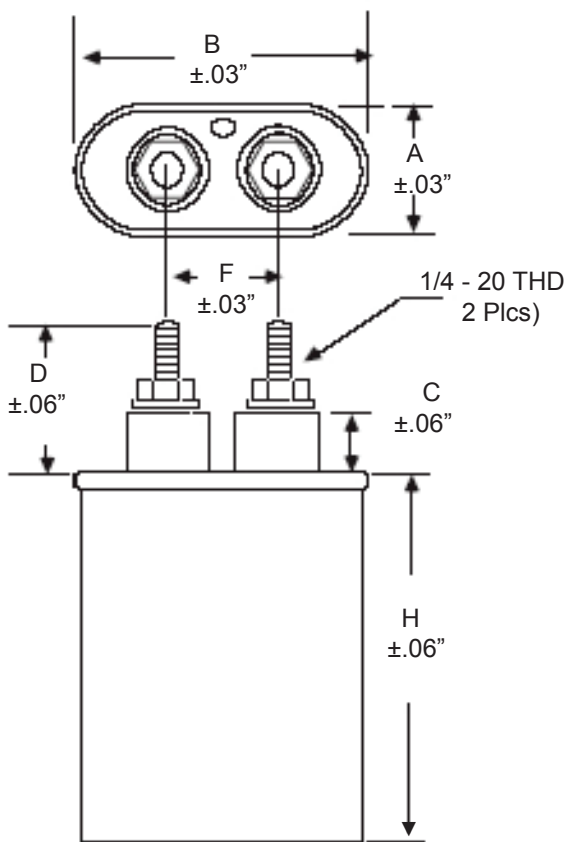

Figure 1

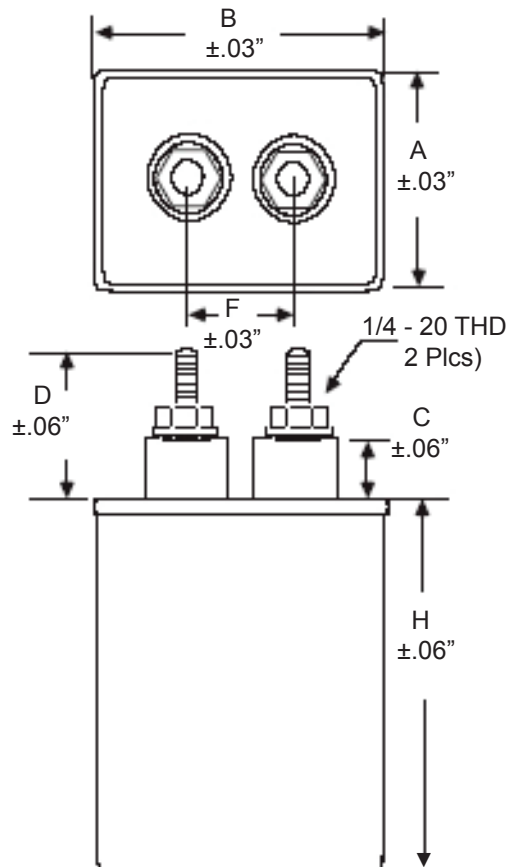

Figure 2

Case Code	Dimensions Inches						Figure
	A	B	C	D	F	H	
A	1.31	2.16	0.56	1.19	0.81	see table	Fig. 1
B	1.56	2.69	0.50	1.13	1.25	see table	Fig. 1
C	1.91	2.91	0.50	1.13	1.38	see table	Fig. 1
D	1.97	3.66	0.50	1.13	1.38	see table	Fig. 1
E	2.84	4.56	0.50	1.13	2.00	see table	Fig. 2
F	3.75	4.56	0.56	1.19	2.00	see table	Fig. 2

Mounting Hardware

See catalog page 5.000 for hardware

Type SCR Commutating Capacitors

How to Choose a Commutating Capacitor

1. From circuit analysis or measurement, determine application values for these six parameters:

- Nominal capacitance in μF
- Current pulse width in μs
- Current pulse period in μs
- Maximum peak voltage
- Continuous AC voltage in V_{rms}
- Maximum volt-amps (VA)

2. Choose a capacitor from the ratings table of the desired nominal capacitance with a peak voltage rating no less than your maximum peak voltage.

3. Check that your application's rms current is no more than the capacitor's Max. Amps RMS. You can calculate

the current from your V_{rms} using the equations in the following section.

4. Check that your application's volt-amperes is not more than the capacitor's VA capability. The VA capability is the max VA rating times the Volt-Ampere multiplier from Figure 2 (Current Pulse Width) and that times the Volt-Ampere Multiplier from Figure 3 (Ambient Temperature). See the following section for more on using volt-ampere multipliers

If you need a greater VA capability, repeat these steps for a higher peak voltage capacitor or consider connecting units in parallel to divide the VA required. For up to peak voltage of 600 V, you may also consider polypropylene film dielectric units, Catalog Numbers SCR262R through SCR266R, with higher VA capability.

Using Volt-Ampere Ratings

The capacitor's maximum VA rating is the maximum product of the sine wave voltage and current that may be applied at 65 °C without overheating the capacitor and reducing its expected life. For other temperatures and pulsed current, use the multipliers of Figures 2 and 3 to derate the Max VA rating.

The Max Amps RMS rating is set by the capability of the capacitor terminals. Exceeding this limit can damage the terminals and cause capacitor failure.

Calculate the capacitor's actual VA load as the product of the rms voltage across the capacitor and the rms current through the capacitor. To calculate rms current for an applied sine wave or squarewave voltage, use these equations.

For a sinewave voltage the current is:

$$I_{\text{rms}} = 2\pi f C V_{\text{rms}} \times 10^{-6}$$

and for a squarewave the current is:

$$I_{\text{rms}} = C \Delta V / [0.64(t/T)^{0.5}] = I_{\text{peak}}(t/T)^{0.5}$$

where (f) is repetition frequency in Hz, C is nominal capacitance in μF , ΔV the peak-to-peak squarewave amplitude in volts, (t) is the pulse width in μs and T is the pulse period in μs .

The peak current for the square wave voltage is:

$$I_{\text{peak}} = C \Delta V / 0.64t$$

Pulse Wave Applications

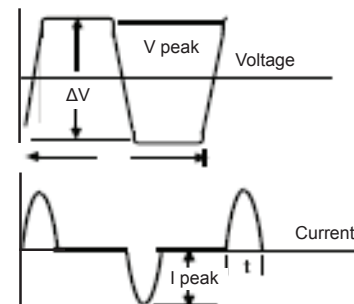

Figure 1

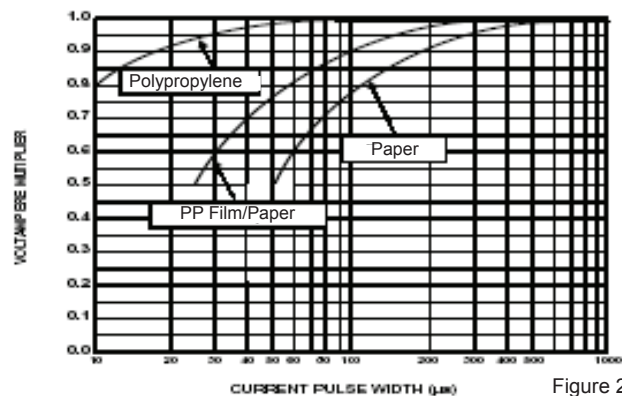

Figure 2

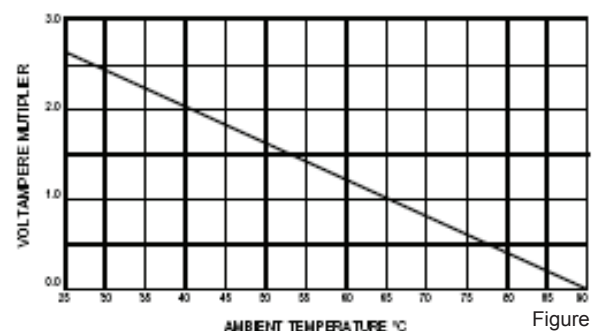

Figure 3