

TITLE
 INDUCTOR,
 PQ3211,
 3.55 μ H, 37.5 ADC

SCHOTT
 CORPORATION
 1000 PARKERS LAKE ROAD
 WAYZATA, MN 55391

AGENCY APPROVAL:
 N/A

PART NUMBER **35071**
 REV B PAGE 1 END

SPECIFICATIONS

1. INDUCTANCE @ 0.01 V, 100 KHz: 3.20 - 3.90 μ H
2. DC RESISTANCE: 1.62 mOHM MAX
3. HIPOT (2 SECONDS, 5 mA MAX):
 300 VRMS WINDING TO CORE.

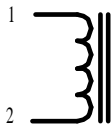

SUGGESTED PCB
 FOOTPRINT IN
 (mm)

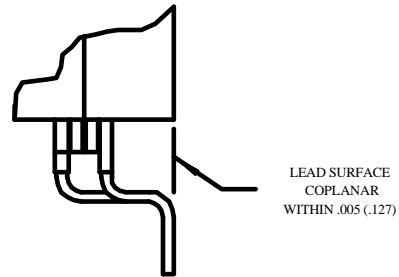
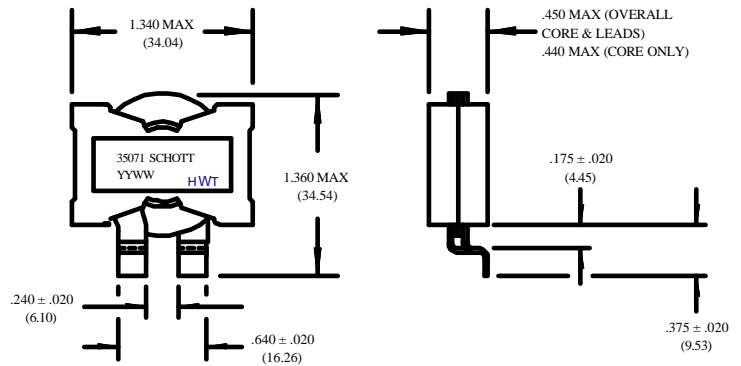
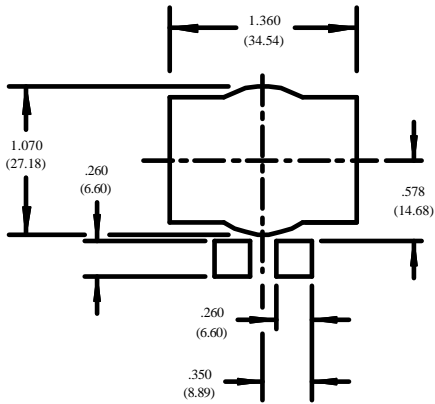

TOLERANCES	2 PLACE	3 PLACE	ANGLE
UNLESS OTHERWISE NOTED	± REF	± REF	± °