

VFD CONTROLLER / DRIVER

DESCRIPTION

SC16313 is a Vacuum Fluorescent Display (VFD) or Fluorescent Indicator Panel (FIP) controller/driver that is driven on a 1/4 to 1/8 duty factor. It consists of 8 segment output lines, 4 grid output lines, 4 segment/grid output lines, one display memory, control circuit, key scan circuit. Serial data is input to SC16313 via a three-line serial interface. This VFD driver is ideal as a peripheral device of a single-chip microcomputer.

FEATURES

- * CMOS technology
- * High-voltage output
- * Key scanning (8 x 2 matrix)
- * Multiple display modes: (8 segments & 8 digits to 12 segments & 4 digits)
- * 8-step dimming circuitry
- * Serial interface (CLK, DIN, DOUT, STB)
- * No external resistors needed for driver outputs

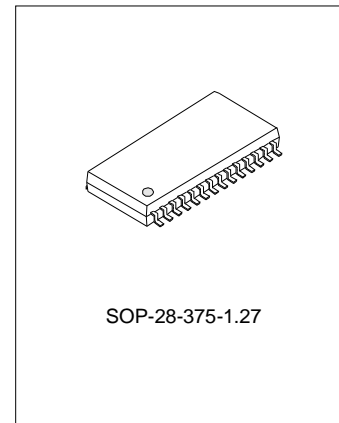

ORDERING INFORMATION

Device	Package
SC16313	SOP-28-375-1.27

APPLICATIONS

- * Microcomputer peripheral device.

BLOCK DIAGRAM

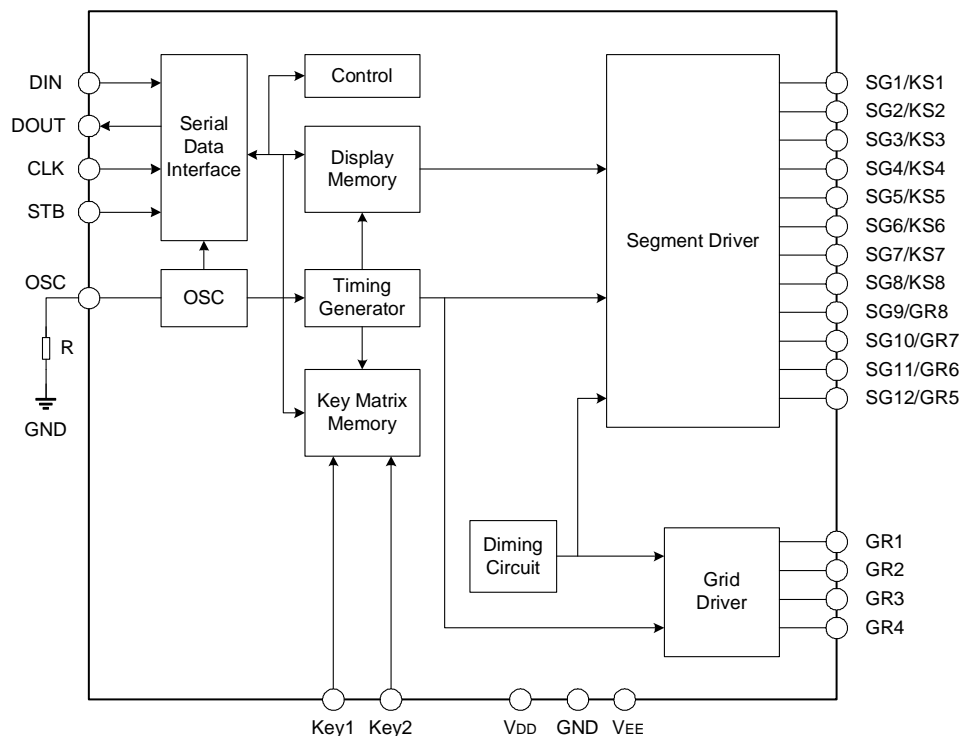

ABSOLUTE MAXIMUM RATINGS (unless otherwise stated, $T_{amb}=25^{\circ}\text{C}$, $\text{GND}=0\text{V}$)

Characteristics	Symbol	Value	Unit
Logic Supply Voltage	VDD	-0.5 to +7	V
Driver Supply Voltage	VEE	VDD +0.5 to VDD-40	V
Logic Input Voltage	VI	-0.5 to VDD+0.5	V
VFD Driver Output Voltage	VO	VEE-0.5 to VDD+0.5	V
VFD Driver Output Current	IoVFD	-40 (grid) -15 (segment)	mA
Operating Ambient Temperature	Topr	-40 to +85	$^{\circ}\text{C}$

RECOMMENDED OPERATING CONDITIONS

 (Unless otherwise stated, $T_{amb}=-20$ to $+70^{\circ}\text{C}$, $\text{GND}=0\text{V}$)

Characteristics	Symbol	Min.	Typ.	Max.	Unit
Logic Supply Voltage	VDD	3.0	5	5.5	V
High-Level Input Voltage	VIH	0.7VDD	--	VDD	V
Low-Level Input Voltage	VIL	0	--	0.3VDD	V
Driver Supply Voltage	VEE	VDD-35	--	0	V

ELECTRICAL CHARACTERISTICS

 (Unless otherwise stated, $\text{VDD}=5\text{V}$, $\text{GND}=0\text{V}$, $\text{VEE}=\text{VDD}-35\text{V}$, $T_{amb}=25^{\circ}\text{C}$)

Characteristics	Symbol	Test Condition	Min.	Typ.	Max.	Unit
Low-Level Output Voltage	VOL1	DOUT, IOL2=4mA	--	--	0.4	V
High-Level Output Current	IOH21	VO=VDD-2V SG1/KS1 to SG8/KS8	-3	--	--	mA
High-Level Output Current	IOH22	VO=VDD-2V GR1 to GR4, SG9/GR8 to SG12/GR5	-15	--	--	mA
Input Current	Ii	VI=VDD or VSS	--	--	± 1	μA
High-Level Input Voltage	VIH	--	0.7VDD	--	--	V
Low-Level Input Voltage	VIL	--	--	--	0.3VDD	V
Oscillation Frequency	fOSC	R=51K Ω	350	500	650	KHz
Dynamic Current Consumption	IDDdyn	Under no load Display OFF	--	--	5	mA

PIN CONFIGURATION

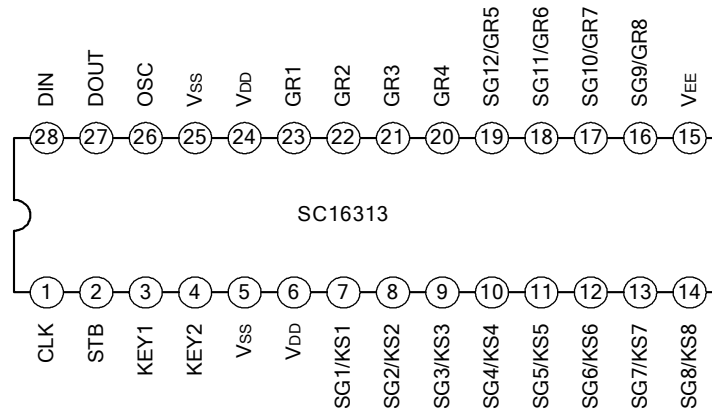

PIN DESCRIPTION

Pin NO.	Symbol	Description
1	CLK	Reads serial data at the rising edge and outputs data at the falling edge.
2	STB	After the STB has fallen, The data input can be processed; the first data is regard as a command. When this pin is "HIGH", CLK is ignored.
3, 4	KEY1 to KEY2	The data input to these pins is latched at the end of display cycle.
5, 25	Vss	Logic ground pin
6, 24	VDD	Logic power supply
7 to 14	SG1/KS1 to SG8/KS8	Segment output pins. It also functions as key source.
15	VEE	VDD – 35 V max
16 to 19	SG9/GR8 ~SG12/GR5	These pins are selectable for segment or grid output
20 to 23	GR4 to GR1	Grid output pins
26	OSC	This pin connects a resistor to VDD to determine the oscillation frequency.
27	DOUT	Outputs serial data at the falling edge of the shift clock (starting from the lower bit).
28	DIN	Inputs serial data at the rising edge of the shift clock (starting from the lower bit).

FUNCTION DESCRIPTION

DISPLAY RAM ADDRESS

Data transmitted from an external device to SC16313 via the serial interface are stored in the display RAM and are assigned addresses. The RAM addresses of SC16313 are given below in 8 bits unit.

SG1	SG4	SG5	SG8	SG9	SG12	
00HL		00HU		01HL		GR1
02HL		02HU		03HL		GR2
04HL		04HU		05HL		GR3
06HL		06HU		07HL		GR4
08HL		08HU		09HL		GR5
0AHL		0AHU		0BHL		GR6
0CHL		0CHU		0DHL		GR7
0EHL		0EHU		0FHL		GR8

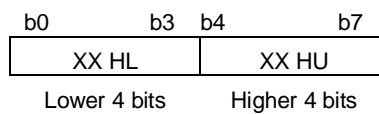

Only the lower 4 bits of the addresses assigned to SG9 through SG12 are valid, and the higher 4 bits are ignored.

SC16313 KEY MATRIX & KEY INPUT DATA STORAGE RAM

SC16313 key matrix consists of 8 x 2 arrays as shown below:

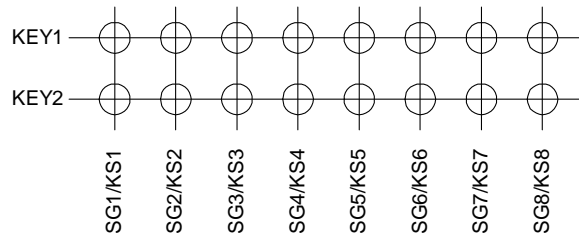

The data of each key is stored in key-input data RAM as illustrated below. They are read by a READ command, starting from the least significant bit. When the most significant bit of the data (SG8, b7) has been read, then the least significant bit of the next data (SG1, b0) will be read.

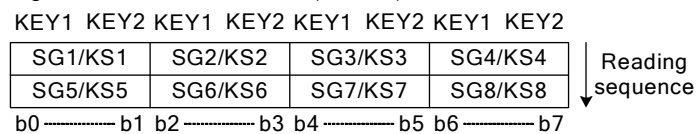

COMMANDS

Commands set the display mode and status of SC16313. The first byte (b0 to b7) inputted to SC16313 via the DIN pin after STB pin has fallen is regarded as a command. If for some reason the STB pin is made "HIGH" while data or commands are being transmitted, the serial communication is initialized, and the

data/command being transmitted is considered invalid. (However, the data/command already transmitted remains valid)

Command 1: display mode setting command

This command initializes the SC16313 and selects the number of segments and number of grids (4 to 8 grids, 12 to 8 segments).

When this command is executed, display is forcibly turned off, and key scanning is also stopped. To resume display, a display ON command must be executed.

SC16313 provides 4 display mode settings as shown in the diagram below. The bits 4 to 6 (b3 to b5) are ignored, bits 7 & 8 (b6 to b7) are given a value of "0".

On power application, the 8-digit, 8-segment mode is selected.

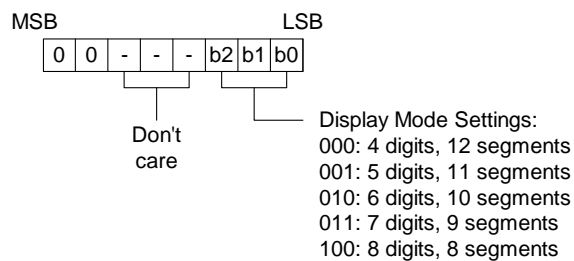

Command 2: data setting command

This command sets data write or data read modes. The data setting command, the bits 6 and 5 (b5, b4) are ignored, bit 8 and bit 7 (b7, b6) are given the value of '01'. Please refer to the diagram below.

On power application, the normal operation mode and address increment mode are set.

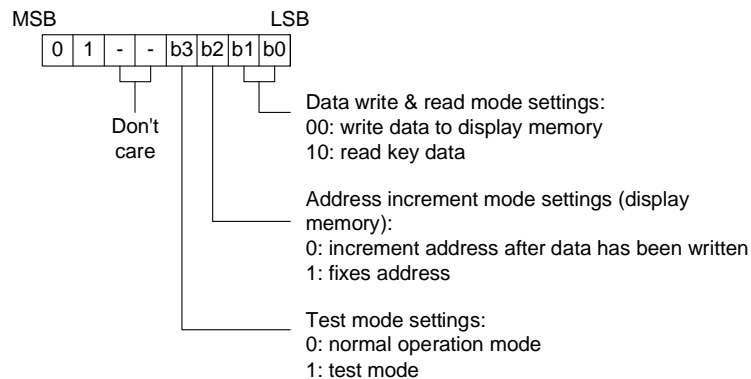

Command 3: address setting command

This command sets an address of the display memory. The address is considered valid if it has a value of "00H" to "0FH". If the address is set to 10H or higher, the data is ignored until a valid address is set.

On power application, the address is set to "00H".

Please refer to the diagram below.

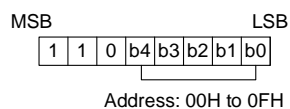

Command 4: display control command

This command is used to turn ON or OFF a display. It also used to set the pulse width. Please refer to the diagram below.

ON power application, the 1/16 pulse width is set and the display is turned OFF (the key scanning starts).

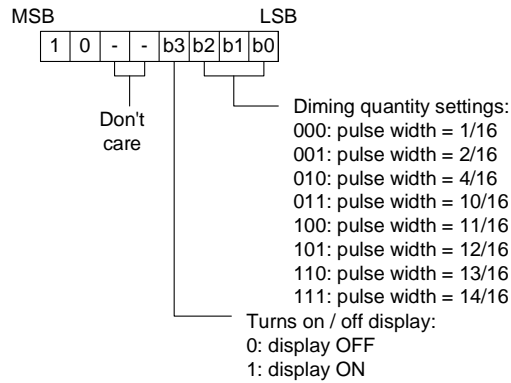

KEY SCANNING AND DISPLAY TIMING

The key scanning and display timing diagram is given below. One cycle of key scanning consists of 2 frames. In the first frame, those keys connected to KS1~KS4 are scanned, while the second frame scans KS5~KS8. The data of the 8 x 2 matrix is stored in the key-input RAM.

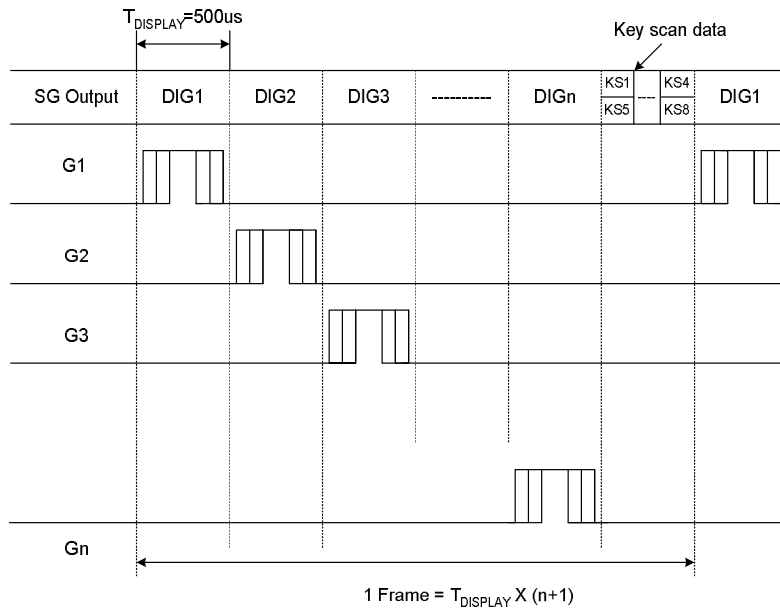

SERIAL COMMUNICATION FORMAT

The following diagram shows the SC16313 serial communication format. The DOUT pin is an N-channel, open-drain output pin. Therefore, it is highly recommended that an external pull-up resistor (1kΩ to 10kΩ) must be connected to DOUT.

RECEPTION (COMMAND/DATA WRITE)

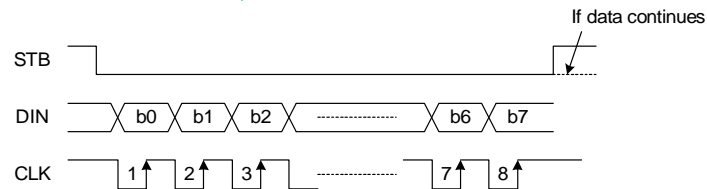

TRANSMISSION (DATA READ)

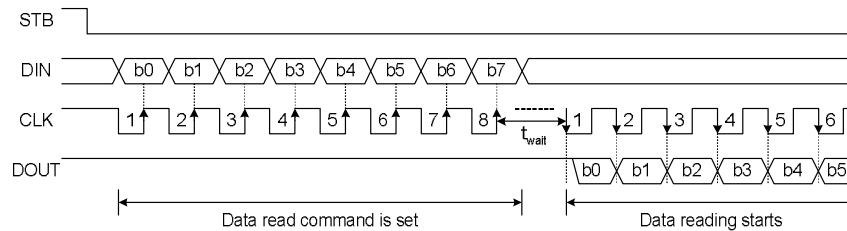

It must be noted that when the data is read, a waiting time t_{wait} of 1μs is necessary between the rising of the eighth clock that has set the command and the falling of the first clock that has read the data.

TYPICAL APPLICATION CIRCUIT

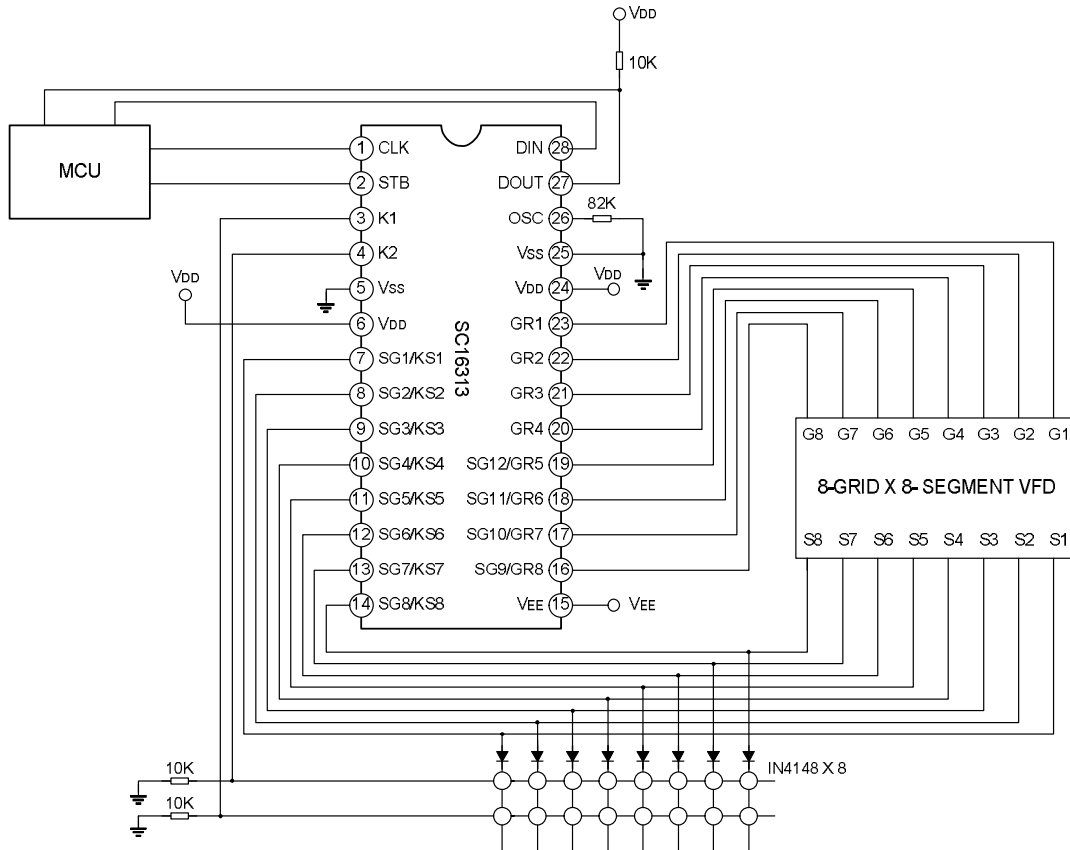

PACKAGE OUTLINE

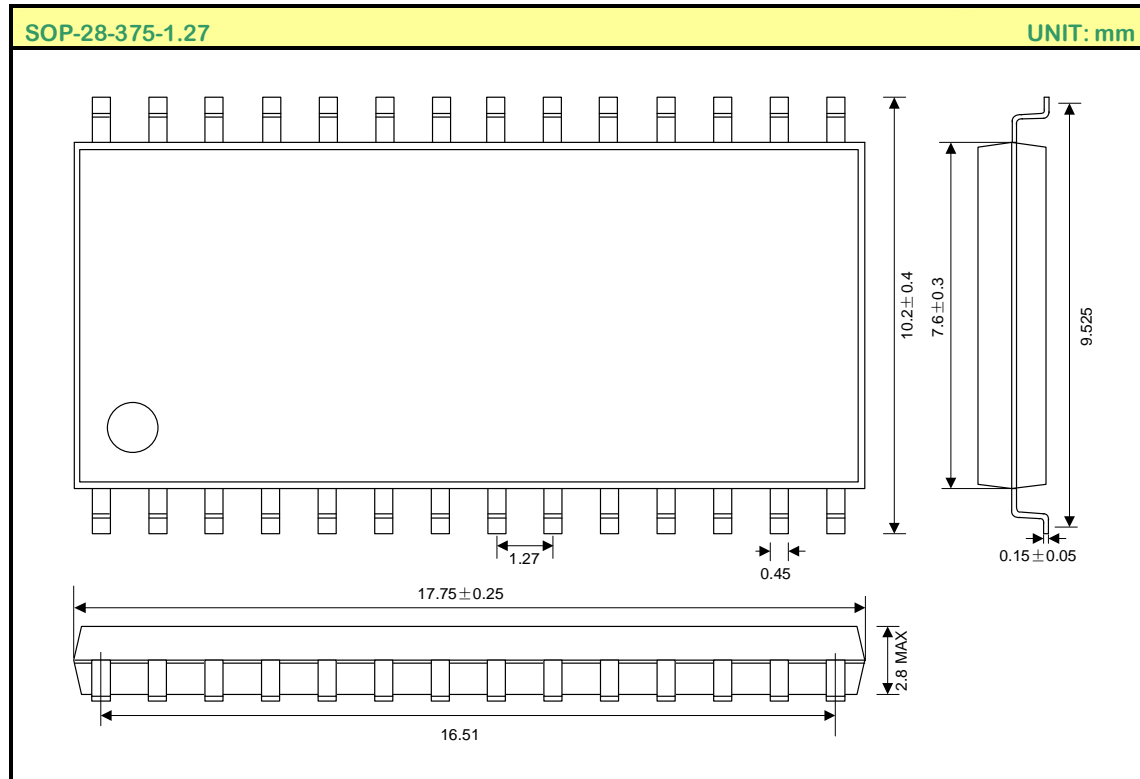

HANDLING MOS DEVICES:

Electrostatic charges can exist in many things. All of our MOS devices are internally protected against electrostatic discharge but they can be damaged if the following precautions are not taken:

- Persons at a work bench should be earthed via a wrist strap.
- Equipment cases should be earthed.
- All tools used during assembly, including soldering tools and solder baths, must be earthed.
- MOS devices should be packed for dispatch in antistatic/conductive containers.

ATTACHMENT

Revision History

Data	REV	Description	Page
2003.04.23	1.0	Original	
2003.07.30	1.1	Del "High-Level Output Voltage" in ELECTRICAL CHARACTERISTICS	3
2003.08.28	1.2	Modify the pin20~pin23 pin name.	--