

REVISION CL

DO NOT SCALE FROM THIS PRINT

DIMENSIONS ARE IN INCHES		UNLESS OTHERWISE NOTED		TOLERANCES ARE:	
ONE PLACE DECIMALS ± .1 [2.5mm]	THREE PLACE DECIMALS ± .001 [0.13mm]	ANGLES ± 2°			
TWO PLACE DECIMALS ± .01 [25mm]	FOUR PLACE DECIMALS ± .002 [26mm]				

TITLE: HIGH TEMP 2MM SMT BOARD STACKING TERMINAL STRIP ASM
 DWG NO: TW-XX-XX-XXX-X-XXX-SM-XXX-XX
 SHEET 1 OF 3

TABLE 1

LEAD STYLE	TERMINAL	MAX "A" ("B" IS .000 [.00] MIN)	"C"	OVERALL PIN LENGTH
-02	T-1S13-02-XXX-2	.309 [7.85]	.377 [9.6]	
-03	T-1S13-03-XXX-2	.467 [11.86]	.535 [13.6]	
-04	T-1S13-06-XXX-2	.487 [12.37]	.555 [14.1]	
-06	T-1S13-10-XXX-2	.605 [15.37]	.673 [17.1]	
-07	T-1S13-11-XXX-2	.683 [17.35]	.751 [19.1]	
-09	T-1S13-13-XXX-2	.388 [9.86]	.456 [11.6]	

- NOTES:
- MAX. PIN ROTATION IN BODY: 2°
 - PUSHOUT FORCE SHALL BE 1 lb MIN.
 - ⊕ REPRESENTS A CRITICAL DIMENSION
 - ALL DIMENSIONS IN BRACKETS [] TO BE MILLIMETERS.
 - HEIGHT VARIATION BETWEEN ANY TWO PINS SHALL BE .010 MAX
 - TUBE POSITIONS -04 THROUGH -36 ONLY; LAYER PACKAGE -02 & -03. TUBE PLUG MUST BE ALLIGNED WITH INSULATOR. (SEE DETAIL ON PAGE 2)
 - MOLDED OR STAKED ALIGNMENT PIN AT SAMTEC'S DISCRETION.
 - SPACE OPTION FROM .170 TO .209 REQUIRES AN ADDITIONAL REPRESS.
 - NOTE DELETED.
 - M OPTION AVAILABLE ON -D ROW ONLY. -M OPTION AVAILABLE ON POSITIONS 4-36 ONLY. -P OPTION AVAILABLE ON 4-36 POSITION ONLY.
 - DUE TO THE HIGH AMOUNT OF INSERTION FORCE NEEDED, THE -LC OPTION IS NOT COMPATIBLE WITH AUTO PLACEMENT. SAMTEC RECOMMENDS MANUAL PLACEMENT FOR ALL ASSEMBLIES WITH THE -LC OPTION.
 - S-A FOR EXISTING BUSINESS ONLY, NEW DESIGNS WILL BE AN ASP.
 - MAX CUT FLASH: .020 [0.51]

- PLATING
- G: 10μ" GOLD IN CONTACT AREA, 10 GOLD ON TAIL (USE T-1S13-XX-G-2)
 - T: MATTE TIN CONTACT AND TAIL (USE T-1S13-XX-T-2)
 - S: 30μ" GOLD IN CONTACT AREA, MATTE TIN ON TAIL (USE T-1S13-XX-S-2)
 - E: 50μ" GOLD IN CONTACT AREA, 3μ" GOLD ON TAIL (USE T-1S13-XX-E-2)
 - L: 10μ" GOLD IN CONTACT AREA, MATTE TIN ON TAIL (USE T-1S13-XX-L-2)
 - F: 3μ" GOLD IN CONTACT AREA, MATTE TIN ON TAIL (USE T-1S13-XX-F-2)
 - P: 2μ" - 5μ" GOLD IN CONTACT AREA, MATTE TIN ON TAIL (USE T-1S13-XX-P-2)
 - TL: TIN/LEAD (90%/10 +/-5%) CONTACT AND TAIL (USE T-1S13-XX-TL-2)
 - STL: 30μ" GOLD IN CONTACT AREA, TIN/LEAD (90%/10 +/-5%) TAIL (USE T-1S13-XX-STL-2)
 - LTL: 10μ" GOLD IN CONTACT AREA, (90%/10 +/-5%) TAIL (USE T-1S13-XX-LTL-2)
 - H: 30μ" GOLD IN CONTACT AREA, 3μ" GOLD ON TAIL (USE T-1S13-XX-H-2)
 - SM: 30μ" GOLD IN CONTACT AREA, MATTE TIN ON TAIL (USE T-1S13-XX-SM-2)
 - TM: MATTE TIN CONTACT AND TAIL (USE T-1S13-XX-TM-2)
 - LM: 10μ" GOLD IN CONTACT AREA, MATTE TIN ON TAIL (USE T-1S13-XX-LM-2)
 - FM: 3μ" GOLD IN CONTACT AREA, MATTE TIN ON TAIL (USE T-1S13-XX-FM-2)
- OPTION 1
- LC: LOCKING CLIP (SEE FIG 2, SHEET 2)(SEE NOTE 11) (-D ROW: USE 2TS-XX-D) (-S ROW: USE 2TS-XX-SV) (.190 MIN BOARD SPACE)
 - *-A: MOLDED ALIGNMENT PIN (SEE FIG 3, SHEET 2 & NOTE 7) (2 POSITIONS WILL ONLY HAVE ONE ALIGNMENT PIN) (-D ROW: USE 2TS-XX-DV-A) (-S ROW: USE 2TS-XX-SV-A) (*=SEE NOTE 12) (BOTTOM BODY ONLY, USE TMM-50-X FOR TOP)
 - STAKED ALIGNMENT PIN (SEE FIG 4, SHEET 2 & NOTE 7) (-D ROW ONLY: USE TMM-50-D, 4 POS MIN) (.190 MIN BOARD SPACE FOR BOTH)
 - P: PICK & PLACE PAD (SEE NOTE 10) (-D ROW: USE PPP-10) (-S ROW: USE PPP-11) NOTE: "B" = .075 [1.91] MIN FOR THIS OPTION (SEE FIG 6)
 - M: METAL PICK & PLACE PAD (SEE NOTE 10) (-D ROW: USE PPP-10) (-S ROW: USE PPP-11) NOTE: "B" MUST BE .075 OR GREATER FOR THIS OPTION. (SEE FIG. 6)
 - TR: TAPE AND REEL PACKAGING (-07 LEAD STYLE NOT AVAILABLE IN T & R) (SEE SHEET 3 FOR -S-TR OPTION ORIENTATION VIEW) (.475 MAX "A" WHEN COMBINED WITH -P OPTION)
- OPTION 2
- XXX: POLARIZED POSITION (SPECIFY OMITTED PIN)
- SPACE OPTION (SEE NOTE 8) XXX="A" (SEE TABLE 1, .170 [4.32] MIN) (*=SEE NOTE 12)
- ROW OPTION
- S: SINGLE ROW (USE TMM-50-S)
 - D: DOUBLE ROW (USE TMM-50-D)

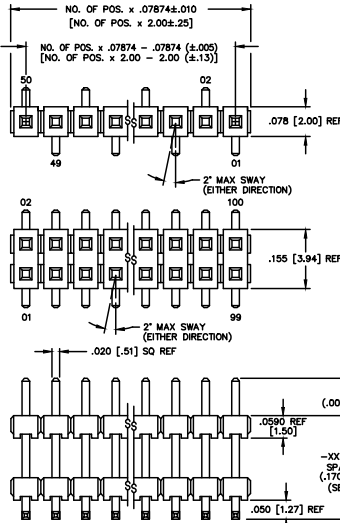
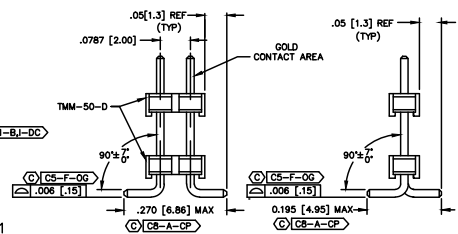
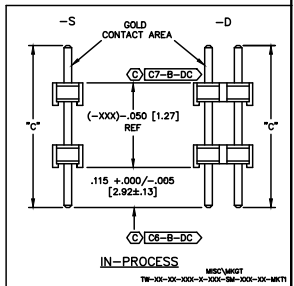

TABLE 2 (SEE NOTE 6)

LEAD STYLE	OPTIONS	TUBE	PLUGS
-02, -04, -07, -09	-D, -D-LC, -D-A	PT-TW001-D-SM	TP-03
-03	-D, -D-LC, -D-A	PT-TW001-D-SM	TP-03
ALL	-S, -S-LC, -S-A	PT-TW002-S-SM	TP-24-02
-02, -09	-D-A-P, -D-LC-P, -D-P, -D-LC-M, -D-A-M, -D-M	PT-TW001-D-SM	TP-03
-03, -04	-D-A-P, -D-LC-P, -D-P, -D-LC-M, -D-A-M, -D-M	PT-TW001-D-SM	TP-03
-07	-D-A-P, -D-LC-P, -D-P, -D-LC-M, -D-A-M, -D-M	PT-TW001-D-SM	TP-03
-02, -09	-S-LC-P, -S-A-P	PT-TW002-S-SM	TP-24-02
-03, -04	-S-LC-P, -S-A-P, -S-P	PT-TW002-S-SM	TP-24-02
-07	-S-LC-P, -S-A-P, -S-P	PT-TW002-S-SM	TP-24-02
-08	-D-LC	PT-TW001-D-SM	TP-03
-06	NONE, -A, -D	PT-TW001-D-SM	TP-03
-08	-D-A-P, -D-LC-P, -D-P, -D-LC-M, -D-A-M, -D-M	PT-TW001-D-SM	TP-03
-08	-S-LC-P, -S-A-P, -S-P	PT-TW002-S-SM	TP-24-02



PATENT NUMBERS
 5713755 / 5961339



MATERIAL:
 INSULATOR:
 LIQUID CRYSTAL POLYMER
 COLOR: BLACK
 TERMINALS:
 PHOSPHOR BRONZE

samtec
 520 PARK EAST BLVD, NEW ALBANY, INDIANA 47150
 PHONE (812) 944-6733 P.O. BOX 1147
 CODE 55322
 MADE BY: BRYANT 3-8-93 TW-XX-XX-XXX-X-XXX-SM-XXX-XX