

4Mb Sync. Pipelined Burst SRAM Specification

**100 TQFP with Pb & Pb-Free
(RoHS compliant)**

**INFORMATION IN THIS DOCUMENT IS PROVIDED IN RELATION TO SAMSUNG PRODUCTS,
AND IS SUBJECT TO CHANGE WITHOUT NOTICE.**

**NOTHING IN THIS DOCUMENT SHALL BE CONSTRUED AS GRANTING ANY LICENSE,
EXPRESS OR IMPLIED, BY ESTOPPEL OR OTHERWISE,**

**TO ANY INTELLECTUAL PROPERTY RIGHTS IN SAMSUNG PRODUCTS OR TECHNOLOGY.
ALL INFORMATION IN THIS DOCUMENT IS PROVIDED**

ON AS "AS IS" BASIS WITHOUT GUARANTEE OR WARRANTY OF ANY KIND.

1. For updates or additional information about Samsung products, contact your nearest Samsung office.
2. Samsung products are not intended for use in life support, critical care, medical, safety equipment, or similar applications where Product failure could result in loss of life or personal or physical harm, or any military or defense application, or any governmental procurement to which special terms or provisions may apply.

* Samsung Electronics reserves the right to change products or specification without notice.

Document Title

128Kx36 & 128Kx32 & 256Kx18-Bit Synchronous Pipelined Burst SRAM

Revision History

<u>Rev. No</u>	<u>History</u>	<u>Draft Date</u>	<u>Remark</u>
0.0	1. Initial draft	May. 15. 2001	Preliminary
0.1	1. Changed DC parameters Icc ; from 350mA to 290mA at -16, from 330mA to 270mA at -15, from 300mA to 250mA at -14, ISB1; from 100mA to 80mA	June. 12. 2001	Preliminary
0.2	1. Delete Pass-Through	June.25. 2001	Preliminary
0.3	1. Add x32 org. and industrial temperature	Aug. 11. 2001	Preliminary
1.0	1. Final spec release 2. Changed Pin Capacitance - Cin ; from 5pF to 4pF - Cout; from 7pF to 6pF	Nov. 15. 2001	Final
2.0	1. Add Pb-free package	Jul. 03. 2006	Final

K7A403600B
K7A403200B
K7A401800B

128Kx36/x32 & 256Kx18 Synchronous SRAM

4Mb SPB SRAM Ordering Information

Org.	VDD (V)	Speed (ns)	Access Time (ns)	Part Number	RoHS Avail.
256Kx18	3.3	6.0	3.5	K7A401800B-P(Q) ¹ C(I) ² 16	√
	3.3	7.2	4.0	K7A401800B-Q ³ C(I)14	•
128Kx32	3.3	6.0	3.5	K7A403200B-P(Q) ¹ C(I) ² 16	√
	3.3	7.2	4.0	K7A403200B-Q ³ C(I)14	•
128Kx36	3.3	6.0	3.5	K7A403600B-P(Q) ¹ C(I) ² 16	√
	3.3	7.2	4.0	K7A403600B-Q ³ C(I)14	•

Note 1. P(Q) [Package type]: P-Pb Free, Q-Pb

2. C(I) [Operating Temperature]: C-Commercial, I-Industrial

3. Support only Pb package parts at this frequency. To use Pb-Free package, use faster frequency parts.

**K7A403600B
K7A403200B
K7A401800B**

128Kx36/x32 & 256Kx18 Synchronous SRAM

PIN CONFIGURATION(TOP VIEW)

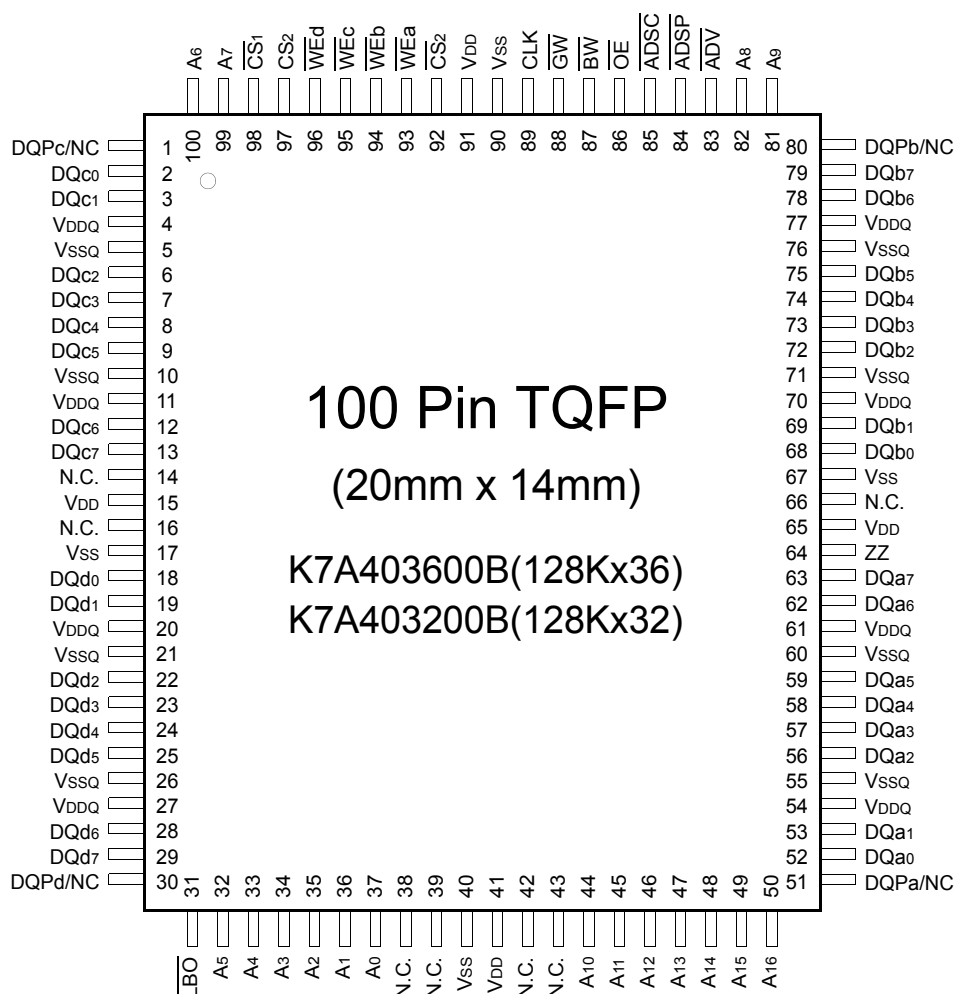

PIN NAME

SYMBOL	PIN NAME	TQFP PIN NO.	SYMBOL	PIN NAME	TQFP PIN NO.
A0 - A16	Address Inputs	32,33,34,35,36,37 44,45,46,47,48,49 50,81,82,99,100	VDD	Power Supply(+3.3V)	15,41,65,91
			VSS	Ground	17,40,67,90
ADV	Burst Address Advance	83	N.C.	No Connect	14, 16,38,39,42,43,66
ADSP	Address Status Processor	84			
ADSC	Address Status Controller	85	DQa0~a7	Data Inputs/Outputs	52,53,56,57,58,59,62,63
CLK	Clock	89	DQb0~b7		68,69,72,73,74,75,78,79
CS1	Chip Select	98	DQc0~c7		2,3,6,7,8,9,12,13
CS2	Chip Select	97	DQd0~d7		18,19,22,23,24,25,28,29
CS2	Chip Select	92	DQPa~Pd		51,80,1,30
WEx	Byte Write Inputs	93,94,95,96	/NC		
(x=a,b,c,d)				Output Power Supply	4,11,20,27,54,61,70,77
OE	Output Enable	86	VDDQ	(2.5V or 3.3V)	
GW	Global Write Enable	88		Output Ground	5,10,21,26,55,60,71,76
BW	Byte Write Enable	87	VSSQ		
ZZ	Power Down Input	64			
LBO	Burst Mode Control	31			

**K7A403600B
K7A403200B
K7A401800B**

128Kx36/x32 & 256Kx18 Synchronous SRAM

PIN CONFIGURATION(TOP VIEW)

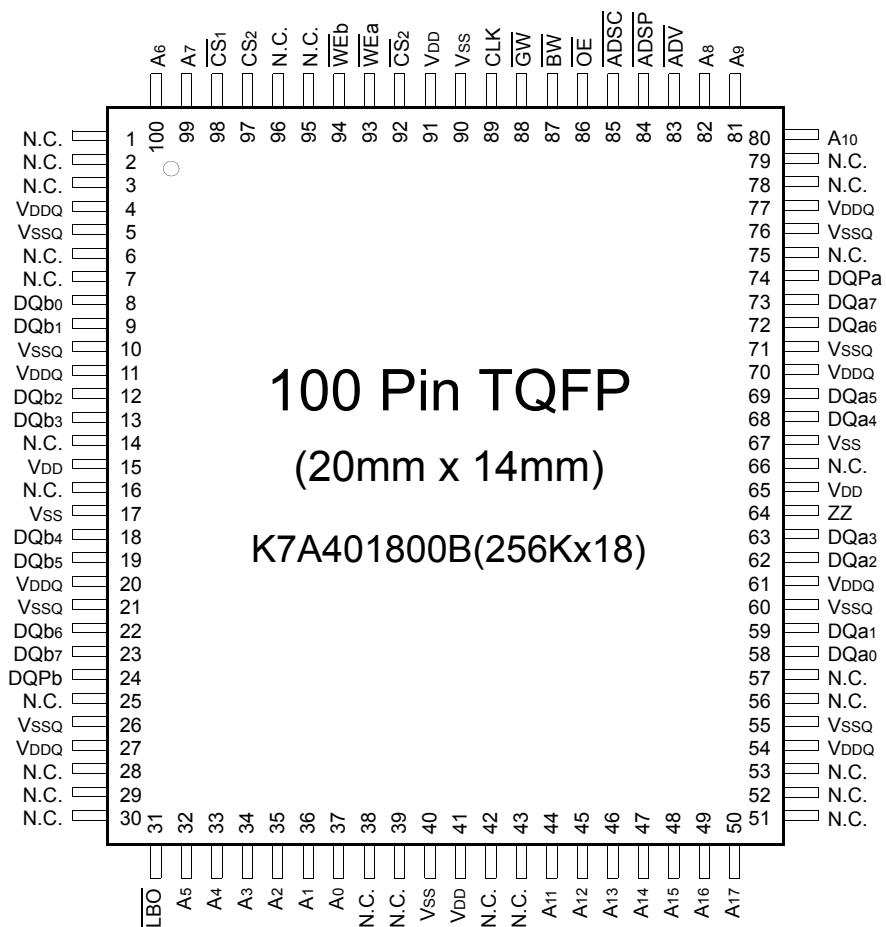

PIN NAME

SYMBOL	PIN NAME	TQFP PIN NO.	SYMBOL	PIN NAME	TQFP PIN NO.
A0 - A17	Address Inputs	32,33,34,35,36,37,44,45,46,47,48,49,50,80,81,82,99,100	VDD	Power Supply(+3.3V)	15,41,65,91
			VSS	Ground	17,40,67,90
			N.C.	No Connect	1,2,3,6,7,14,16,25,28,29,30,38,39,42,43,51,52,53,56,57,66,75,78,79,95,96
ADV	Burst Address Advance	83			
ADSP	Address Status Processor	84			
ADSC	Address Status Controller	85			
CLK	Clock	89	DQa0~a7	Data Inputs/Outputs	58,59,62,63,68,69,72,73
CS1	Chip Select	98	DQb0~b7		8,9,12,13,18,19,22,23
CS2	Chip Select	97	DQPa, Pb		74,24
CS2	Chip Select	92	VDDQ	Output Power Supply (2.5V or 3.3V)	4,11,20,27,54,61,70,77
WEx (x=a,b)	Byte Write Inputs	93,94	VSSQ	Output Ground	5,10,21,26,55,60,71,76
OE	Output Enable	86			
GW	Global Write Enable	88			
BW	Byte Write Enable	87			
ZZ	Power Down Input	64			
LBO	Burst Mode Control	31			

FUNCTION DESCRIPTION

The K7A4036/3200B and K7A401800B are synchronous SRAM designed to support the burst address accessing sequence of the P6 and Power PC based microprocessor. All inputs (with the exception of \overline{OE} , LBO and ZZ) are sampled on rising clock edges. The start and duration of the burst access is controlled by \overline{ADSC} , \overline{ADSP} and \overline{ADV} and chip select pins.

The accesses are enabled with the chip select signals and output enabled signals. Wait states are inserted into the access with \overline{ADV} . When ZZ is pulled high, the SRAM will enter a Power Down State. At this time, internal state of the SRAM is preserved. When ZZ returns to low, the SRAM normally operates after 2cycles of wake up time. ZZ pin is pulled down internally.

Read cycles are initiated with \overline{ADSP} (regardless of \overline{WEx} and \overline{ADSC})using the new external address clocked into the on-chip address register whenever \overline{ADSP} is sampled low, the chip selects are sampled active, and the output buffer is enabled with \overline{OE} . In read operation the data of cell array accessed by the current address, registered in the Data-out registers by the positive edge of CLK, are carried to the Data-out buffer by the next positive edge of CLK. The data, registered in the Data-out buffer, are projected to the output pins. \overline{ADV} is ignored on the clock edge that samples \overline{ADSP} asserted, but is sampled on the subsequent clock edges. The address increases internally for the next access of the burst when \overline{WEx} are sampled High and \overline{ADV} is sampled low. And \overline{ADSP} is blocked to control signals by disabling $\overline{CS1}$.

All byte write is done by \overline{GW} (regardless of \overline{BW} and \overline{WEx}), and each byte write is performed by the combination of \overline{BW} and \overline{WEx} when \overline{GW} is high.

Write cycles are performed by disabling the output buffers with \overline{OE} and asserting \overline{WEx} . \overline{WEx} are ignored on the clock edge that samples \overline{ADSP} low, but are sampled on the subsequent clock edges. The output buffers are disabled when \overline{WEx} are sampled Low(regardless of \overline{OE}). Data is clocked into the data input register when \overline{WEx} sampled Low. The address increases internally to the next address of burst, if both \overline{WEx} and \overline{ADV} are sampled Low. Individual byte write cycles are performed by any one or more byte write enable signals(\overline{WEa} , \overline{WEb} , \overline{WEc} or \overline{WEd}) sampled low. The \overline{WEa} control DQa0 ~ DQa7 and DQPa, \overline{WEb} controls DQb0 ~ DQb7 and DQPb, \overline{WEc} controls DQc0 ~ DQc7 and DQPC, and \overline{WEd} control DQd0 ~ DQd7 and DQPd. Read or write cycle may also be initiated with \overline{ADSC} , instead of \overline{ADSP} . The differences between cycles initiated with \overline{ADSC} and \overline{ADSP} as are follows;

\overline{ADSP} must be sampled high when \overline{ADSC} is sampled low to initiate a cycle with \overline{ADSC} .

\overline{WEx} are sampled on the same clock edge that sampled \overline{ADSC} low(and \overline{ADSP} high).

Addresses are generated for the burst access as shown below, The starting point of the burst sequence is provided by the external address. The burst address counter wraps around to its initial state upon completion. The burst sequence is determined by the state of the LBO pin. When this pin is Low, linear burst sequence is selected. When this pin is High, Interleaved burst sequence is selected.

BURST SEQUENCE TABLE

(Interleaved Burst)

\overline{LBO} PIN	HIGH	Case 1		Case 2		Case 3		Case 4	
		A1	A0	A1	A0	A1	A0	A1	A0
First Address ↓ Fourth Address		0	0	0	1	1	0	1	1
		0	1	0	0	1	1	1	0
		1	0	1	1	0	0	0	1
		1	1	1	0	0	1	0	0

Note: 1. \overline{LBO} pin must be tied to High or Low, and Floating State must not be allowed.

(Linear Burst)

\overline{LBO} PIN	LOW	Case 1		Case 2		Case 3		Case 4	
		A1	A0	A1	A0	A1	A0	A1	A0
First Address ↓ Fourth Address		0	0	0	1	1	0	1	1
		0	1	1	0	1	1	0	0
		1	0	1	1	0	0	0	1
		1	1	0	0	0	1	1	0

Note : 1. \overline{LBO} pin must be tied to High or Low, and Floating State must not be allowed.

ASYNCHRONOUS TRUTH TABLE

(See Notes 1 and 2):

OPERATION	ZZ	\overline{OE}	I/O STATUS
Sleep Mode	H	X	High-Z
Read	L	L	DQ
	L	H	High-Z
Write	L	X	Din, High-Z
Deselected	L	X	High-Z

Notes

1. X means "Don't Care".
2. ZZ pin is pulled down internally
3. For write cycles that following read cycles, the output buffers must be disabled with \overline{OE} , otherwise data bus contention will occur.
4. Sleep Mode means power down state of which stand-by current does not depend on cycle time.
5. Deselected means power down state of which stand-by current depends on cycle time.

TRUTH TABLES

SYNCHRONOUS TRUTH TABLE

\overline{CS}_1	CS_2	\overline{CS}_2	\overline{ADSP}	\overline{ADSC}	\overline{ADV}	\overline{WRITE}	CLK	ADDRESS ACCESSED	OPERATION
H	X	X	X	L	X	X	↑	N/A	Not Selected
L	L	X	L	X	X	X	↑	N/A	Not Selected
L	X	H	L	X	X	X	↑	N/A	Not Selected
L	L	X	X	L	X	X	↑	N/A	Not Selected
L	X	H	X	L	X	X	↑	N/A	Not Selected
L	H	L	L	X	X	X	↑	External Address	Begin Burst Read Cycle
L	H	L	H	L	X	L	↑	External Address	Begin Burst Write Cycle
L	H	L	H	L	X	H	↑	External Address	Begin Burst Read Cycle
X	X	X	H	H	L	H	↑	Next Address	Continue Burst Read Cycle
H	X	X	X	H	L	H	↑	Next Address	Continue Burst Read Cycle
X	X	X	H	H	L	L	↑	Next Address	Continue Burst Write Cycle
H	X	X	X	H	L	L	↑	Next Address	Continue Burst Write Cycle
X	X	X	H	H	H	H	↑	Current Address	Suspend Burst Read Cycle
H	X	X	X	H	H	H	↑	Current Address	Suspend Burst Read Cycle
X	X	X	H	H	H	L	↑	Current Address	Suspend Burst Write Cycle
H	X	X	X	H	H	L	↑	Current Address	Suspend Burst Write Cycle

- Notes:** 1. X means "Don't Care". 2. The rising edge of clock is symbolized by ↑.
 3. $\overline{WRITE} = L$ means Write operation in WRITE TRUTH TABLE.
 $\overline{WRITE} = H$ means Read operation in WRITE TRUTH TABLE.
 4. Operation finally depends on status of asynchronous input pins(ZZ and \overline{OE}).

WRITE TRUTH TABLE(x36/32)

\overline{GW}	\overline{BW}	\overline{WE}_a	\overline{WE}_b	\overline{WE}_c	\overline{WE}_d	OPERATION
H	H	X	X	X	X	READ
H	L	H	H	H	H	READ
H	L	L	H	H	H	WRITE BYTE a
H	L	H	L	H	H	WRITE BYTE b
H	L	H	H	L	L	WRITE BYTE c and d
H	L	L	L	L	L	WRITE ALL BYTES
L	X	X	X	X	X	WRITE ALL BYTES

- Notes:** 1. X means "Don't Care".
 2. All inputs in this table must meet setup and hold time around the rising edge of CLK(↑).

WRITE TRUTH TABLE(x18)

\overline{GW}	\overline{BW}	\overline{WE}_a	\overline{WE}_b	OPERATION
H	H	X	X	READ
H	L	H	H	READ
H	L	L	H	WRITE BYTE a
H	L	H	L	WRITE BYTE b
H	L	L	L	WRITE ALL BYTES
L	X	X	X	WRITE ALL BYTES

- Notes:** 1. X means "Don't Care".
 2. All inputs in this table must meet setup and hold time around the rising edge of CLK(↑).

ABSOLUTE MAXIMUM RATINGS*

PARAMETER	SYMBOL	RATING	UNIT	
Voltage on VDD Supply Relative to VSS	VDD	-0.3 to 4.6	V	
Voltage on VDDQ Supply Relative to VSS	VDDQ	VDD	V	
Voltage on Input Pin Relative to VSS	VIN	-0.3 to VDD+0.3	V	
Voltage on I/O Pin Relative to VSS	VIO	-0.3 to VDDQ+0.3	V	
Power Dissipation	Pd	2.2	W	
Storage Temperature	TSTG	-65 to 150	°C	
Operating Temperature	Commercial	TOPR	0 to 70	°C
	Industrial	TOPR	-40 to 85	°C
Storage Temperature Range Under Bias	TBIAS	-10 to 85	°C	

*Note: Stresses greater than those listed under "Absolute Maximum Ratings" may cause permanent damage to the device. This is a stress rating only and functional operation of the device at these or any other conditions above those indicated in the operating sections of this specification is not implied. Exposure to absolute maximum rating conditions for extended periods may affect reliability.

OPERATING CONDITIONS at 3.3V I/O (0°C ≤ TA ≤ 70°C)

PARAMETER	SYMBOL	MIN	Typ.	MAX	UNIT
Supply Voltage	VDD	3.135	3.3	3.6	V
	VDDQ	3.135	3.3	3.6	V
Ground	VSS	0	0	0	V

* The above parameters are also guaranteed at industrial temperature range.

OPERATING CONDITIONS at 2.5V I/O (0°C ≤ TA ≤ 70°C)

PARAMETER	SYMBOL	MIN	Typ.	MAX	UNIT
Supply Voltage	VDD	3.135	3.3	3.6	V
	VDDQ	2.375	2.5	2.9	V
Ground	VSS	0	0	0	V

* The above parameters are also guaranteed at industrial temperature range.

CAPACITANCE*(TA=25°C, f=1MHz)

PARAMETER	SYMBOL	TEST CONDITION	TYP	MAX	UNIT
Input Capacitance	CIN	VIN=0V	-	4	pF
Output Capacitance	COU	VOUT=0V	-	6	pF

*Note : Sampled not 100% tested.

DC ELECTRICAL CHARACTERISTICS($T_A=0$ to 70°C , $V_{DD}=3.3\text{V}+0.3\text{V}/-0.165\text{V}$)

PARAMETER	SYMBOL	TEST CONDITIONS	MIN	MAX	UNIT	
Input Leakage Current(except ZZ)	I _{IL}	V _{DD} = Max; V _{IN} =V _{SS} to V _{DD}	-2	+2	μA	
Output Leakage Current	I _{OL}	Output Disabled, V _{OUT} =V _{SS} to V _{DDQ}	-2	+2	μA	
Operating Current	I _{CC}	Device Selected, I _{OUT} =0mA, ZZ≤V _{IL} , All Inputs=V _{IL} or V _{IH} , Cycle Time ≥cyc Min.	-16	-	290	mA
			-14	-	250	
Standby Current	I _{SB}	Device deselected, I _{OUT} =0mA, ZZ≤V _{IL} , f = Max, All Inputs≤0.2V or ≥ V _{DD} -0.2V	-16	-	140	mA
			-14	-	130	
	I _{SB1}	Device deselected, I _{OUT} =0mA, ZZ≤0.2V, f = 0, All Inputs=fixed (V _{DD} -0.2V or 0.2V)	-	-	80	mA
	I _{SB2}	Device deselected, I _{OUT} =0mA, ZZ≥V _{DD} -0.2V, f = Max, All Inputs≤V _{IL} or ≥V _{IH}	-	-	50	mA
Output Low Voltage(3.3V I/O)	V _{OL}	I _{OL} = 8.0mA	-	0.4	V	
Output High Voltage(3.3V I/O)	V _{OH}	I _{OH} = -4.0mA	2.4	-	V	
Output Low Voltage(2.5V I/O)	V _{OL}	I _{OL} = 1.0mA	-	0.4	V	
Output High Voltage(2.5V I/O)	V _{OH}	I _{OH} = -1.0mA	2.0	-	V	
Input Low Voltage(3.3V I/O)	V _{IL}		-0.5*	0.8	V	
Input High Voltage(3.3V I/O)	V _{IH}		2.0	V _{DD} +0.3**	V	
Input Low Voltage(2.5V I/O)	V _{IL}		-0.3*	0.7	V	
Input High Voltage(2.5V I/O)	V _{IH}		1.7	V _{DD} +0.3**	V	

The above parameters are also guaranteed at industrial temperature range.

* V_{IL}(Min)=-2.0(Pulse Width ≤ t_{CYC}/2)

** V_{IH}(Max)=4.6(Pulse Width ≤ t_{CYC}/2)

** In Case of I/O Pins, the Max. V_{IH}=V_{DDQ}+0.3V

TEST CONDITIONS

(V_{DD}=3.3V+0.3V/-0.165V, V_{DDQ}=3.3V+0.3/-0.165V or V_{DD}=3.3V+0.3V/-0.165V, V_{DDQ}=2.5V+0.4V/-0.125V, T_A=0 to 70°C)

PARAMETER	VALUE
Input Pulse Level(for 3.3V I/O)	0 to 3V
Input Pulse Level(for 2.5V I/O)	0 to 2.5V
Input Rise and Fall Time(Measured at 0.3V and 2.7V for 3.3V I/O)	1ns
Input Rise and Fall Time(Measured at 0.3V and 2.1V for 2.5V I/O)	1ns
Input and Output Timing Reference Levels for 3.3V I/O	1.5V
Input and Output Timing Reference Levels for 2.5V I/O	V _{DDQ} /2
Output Load	See Fig. 1

* The above parameters are also guaranteed at industrial temperature range.

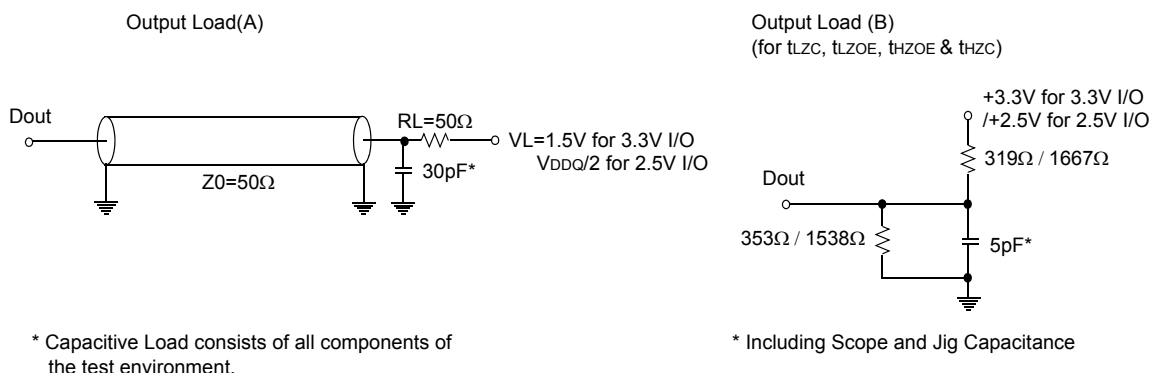

Fig. 1

AC TIMING CHARACTERISTICS($T_A=0$ to 70°C , $V_{DD}=3.3\text{V}+0.3\text{V}/-0.165\text{V}$)

PARAMETER	Symbol	-16		-14		Unit
		Min.	Max	Min.	Max	
Cycle Time	tCYC	6.0	-	7.2	-	ns
Clock Access Time	tCD	-	3.5	-	4.0	ns
Output Enable to Data Valid	tOE	-	3.5	-	4.0	ns
Clock High to Output Low-Z	tLZC	0	-	0	-	ns
Output Hold from Clock High	tOH	1.5	-	1.5	-	ns
Output Enable Low to Output Low-Z	tLZOE	0	-	0	-	ns
Output Enable High to Output High-Z	tHZOE	-	3.5	-	4.0	ns
Clock High to Output High-Z	tHZC	1.5	3.5	1.5	4.0	ns
Clock High Pulse Width	tCH	2.4	-	2.8	-	ns
Clock Low Pulse Width	tCL	2.4	-	2.8	-	ns
Address Setup to Clock High	tAS	1.5	-	1.5	-	ns
Address Status Setup to Clock High	tSS	1.5	-	1.5	-	ns
Data Setup to Clock High	tDS	1.5	-	1.5	-	ns
Write Setup to Clock High (\overline{GW} , \overline{BW} , \overline{WEX})	tWS	1.5	-	1.5	-	ns
Address Advance Setup to Clock High	tADVS	1.5	-	1.5	-	ns
Chip Select Setup to Clock High	tCSS	1.5	-	1.5	-	ns
Address Hold from Clock High	tAH	0.5	-	0.5	-	ns
Address Status Hold from Clock High	tSH	0.5	-	0.5	-	ns
Data Hold from Clock High	tDH	0.5	-	0.5	-	ns
Write Hold from Clock High (\overline{GW} , \overline{BW} , \overline{WEX})	tWH	0.5	-	0.5	-	ns
Address Advance Hold from Clock High	tADVH	0.5	-	0.5	-	ns
Chip Select Hold from Clock High	tCSH	0.5	-	0.5	-	ns
ZZ High to Power Down	tPDS	2	-	2	-	cycle
ZZ Low to Power Up	tPUS	2	-	2	-	cycle

- Notes:**
- The above parameters are also guaranteed at industrial temperature range.
 - All address inputs must meet the specified setup and hold times for all rising clock edges whenever \overline{ADSC} and/or \overline{ADSP} is sampled low and \overline{CS} is sampled low. All other synchronous inputs must meet the specified setup and hold times whenever this device is chip selected.
 - Both chip selects must be active whenever \overline{ADSC} or \overline{ADSP} is sampled low in order for the this device to remain enabled.
 - \overline{ADSC} or \overline{ADSP} must not be asserted for at least 2 Clock after leaving ZZ state.

TIMING WAVEFORM OF READ CYCLE

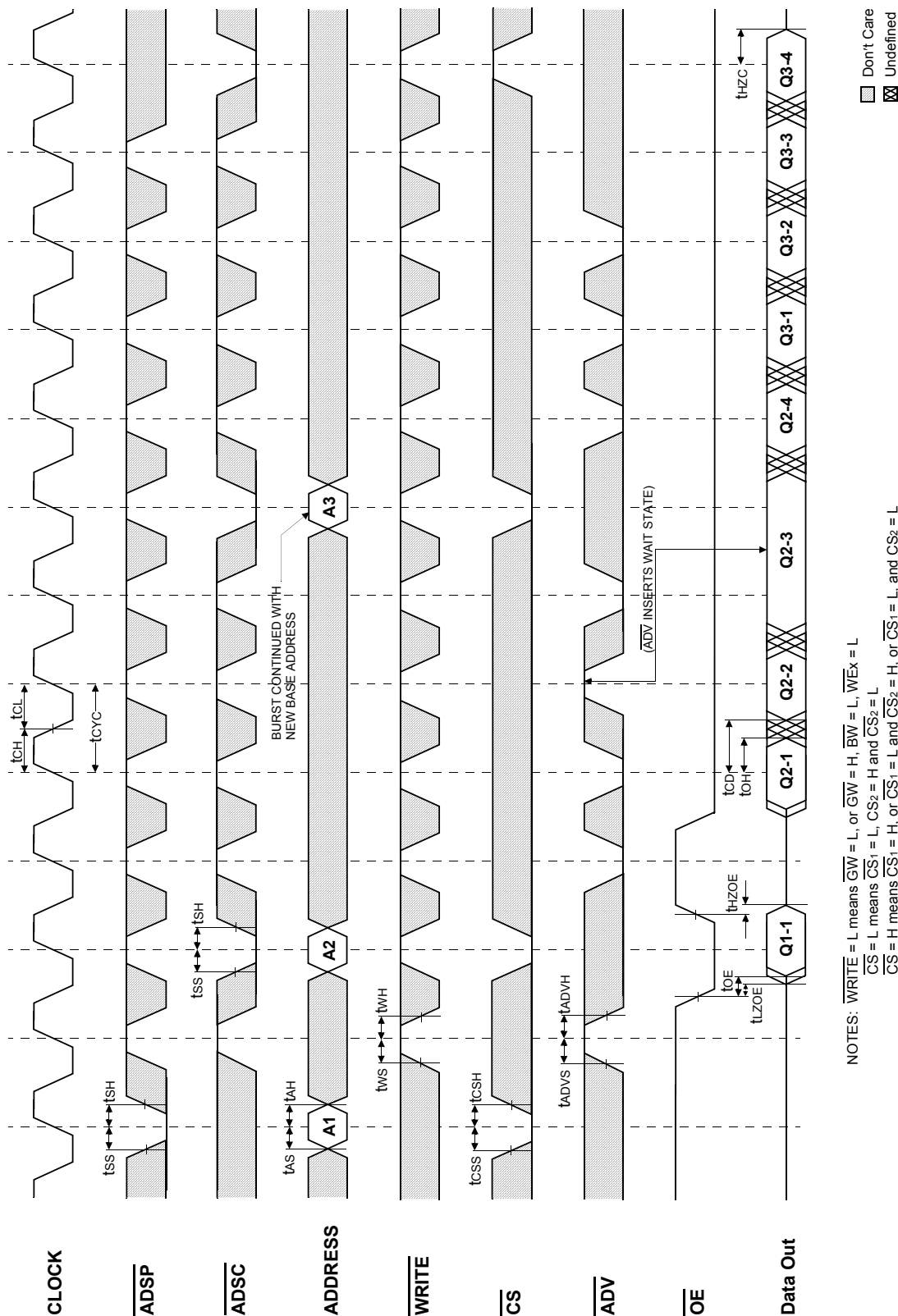

TIMING WAVEFORM OF WRTE CYCLE

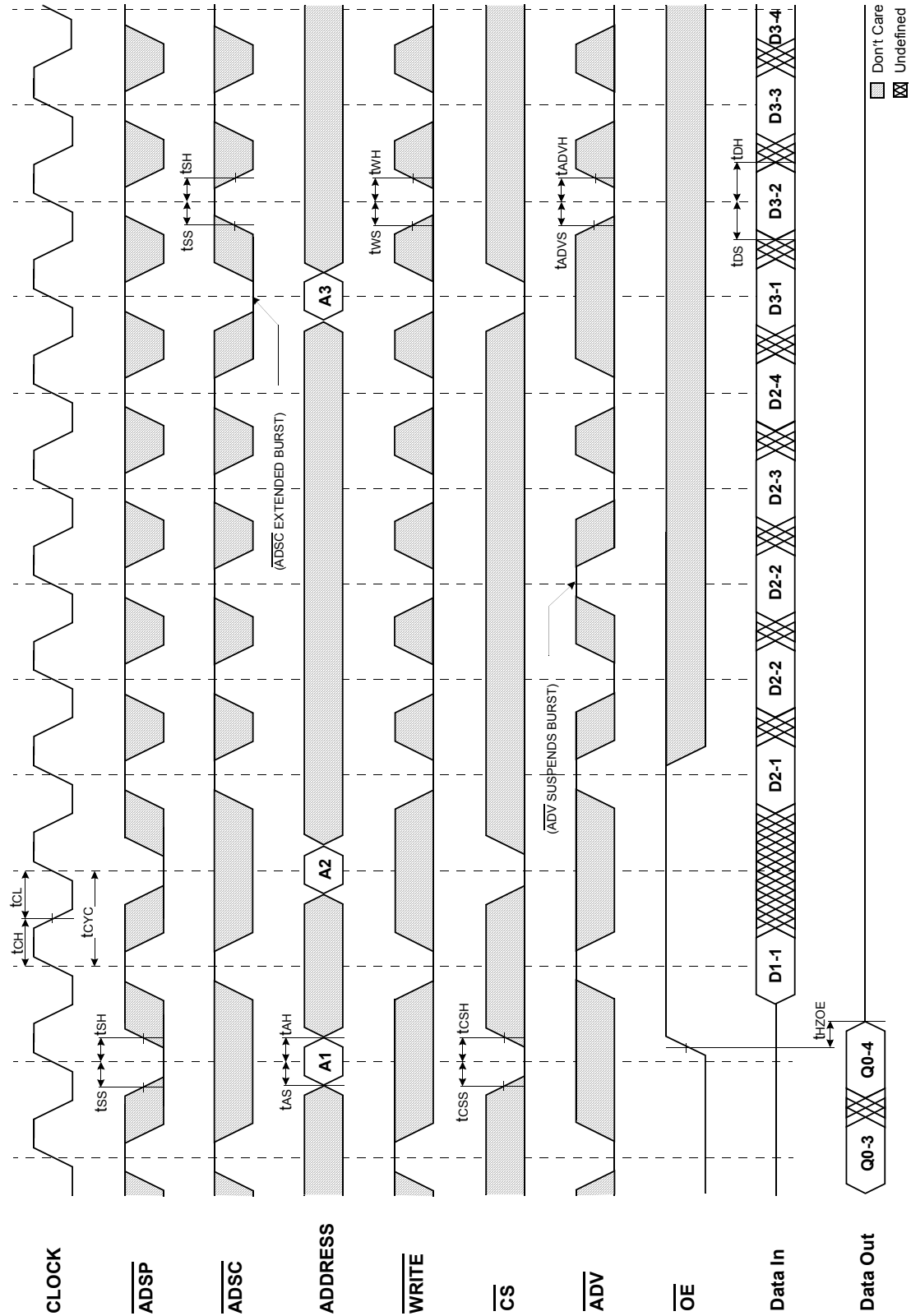

TIMING WAVEFORM OF COMBINATION READ/WRITE CYCLE(ADSP CONTROLLED, $\overline{\text{ADSC}}=\text{HIGH}$)

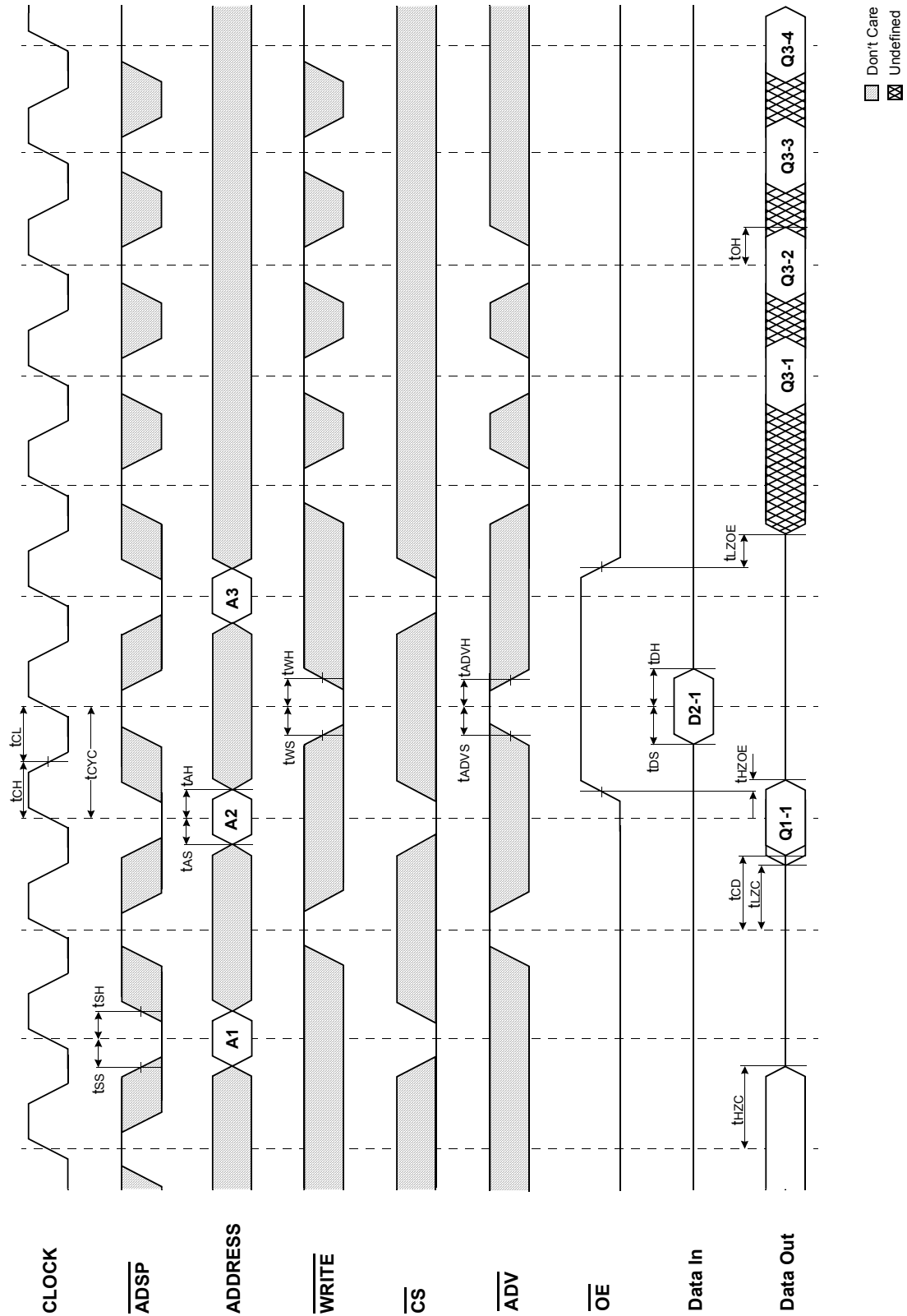

TIMING WAVEFORM OF SINGLE READ/WRITE CYCLE (ADSC CONTROLLED, $\overline{\text{ADSP}}=\text{HIGH}$)

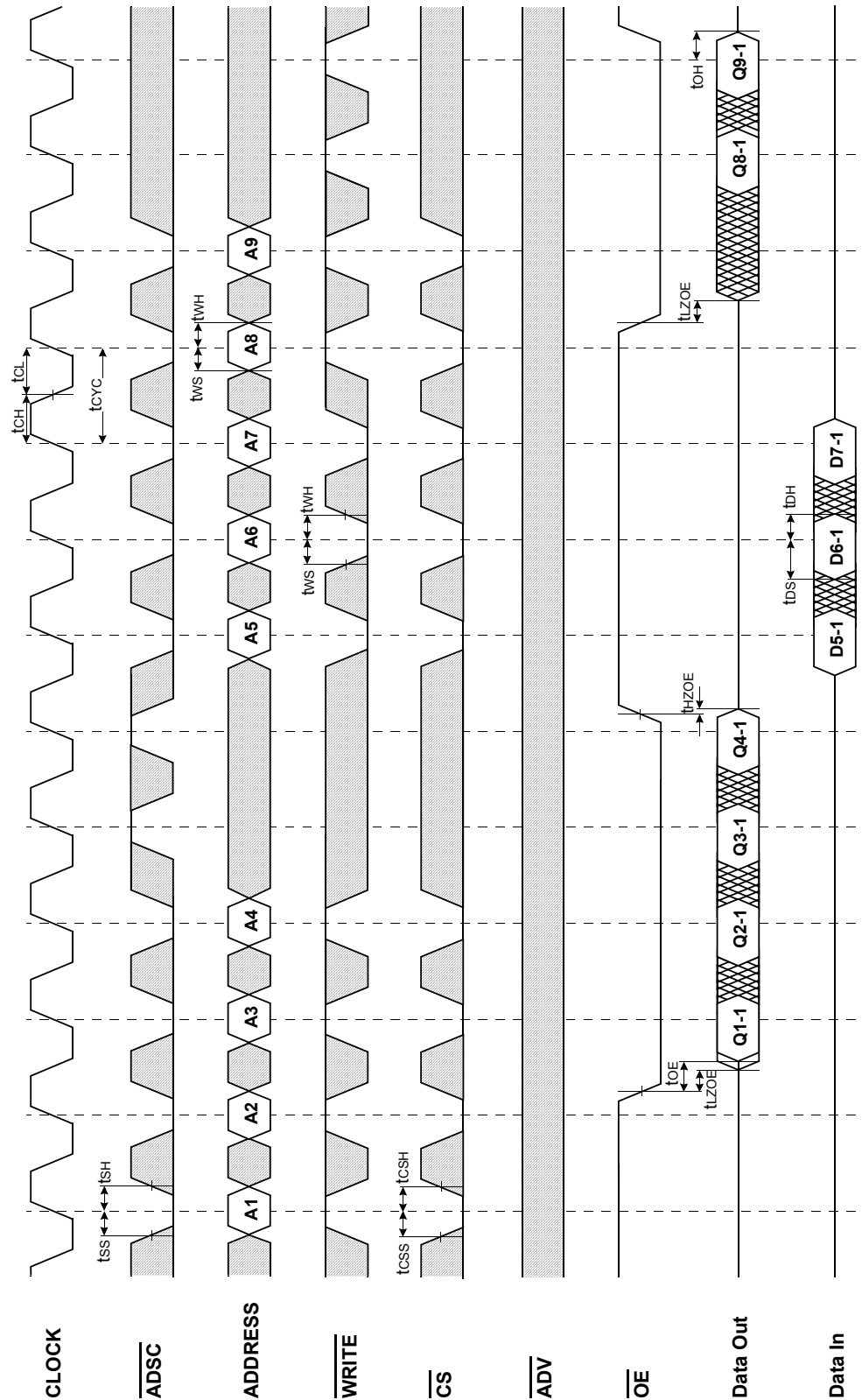

□ Don't Care
 ⊠ Undefined

TIMING WAVEFORM OF POWER DOWN CYCLE

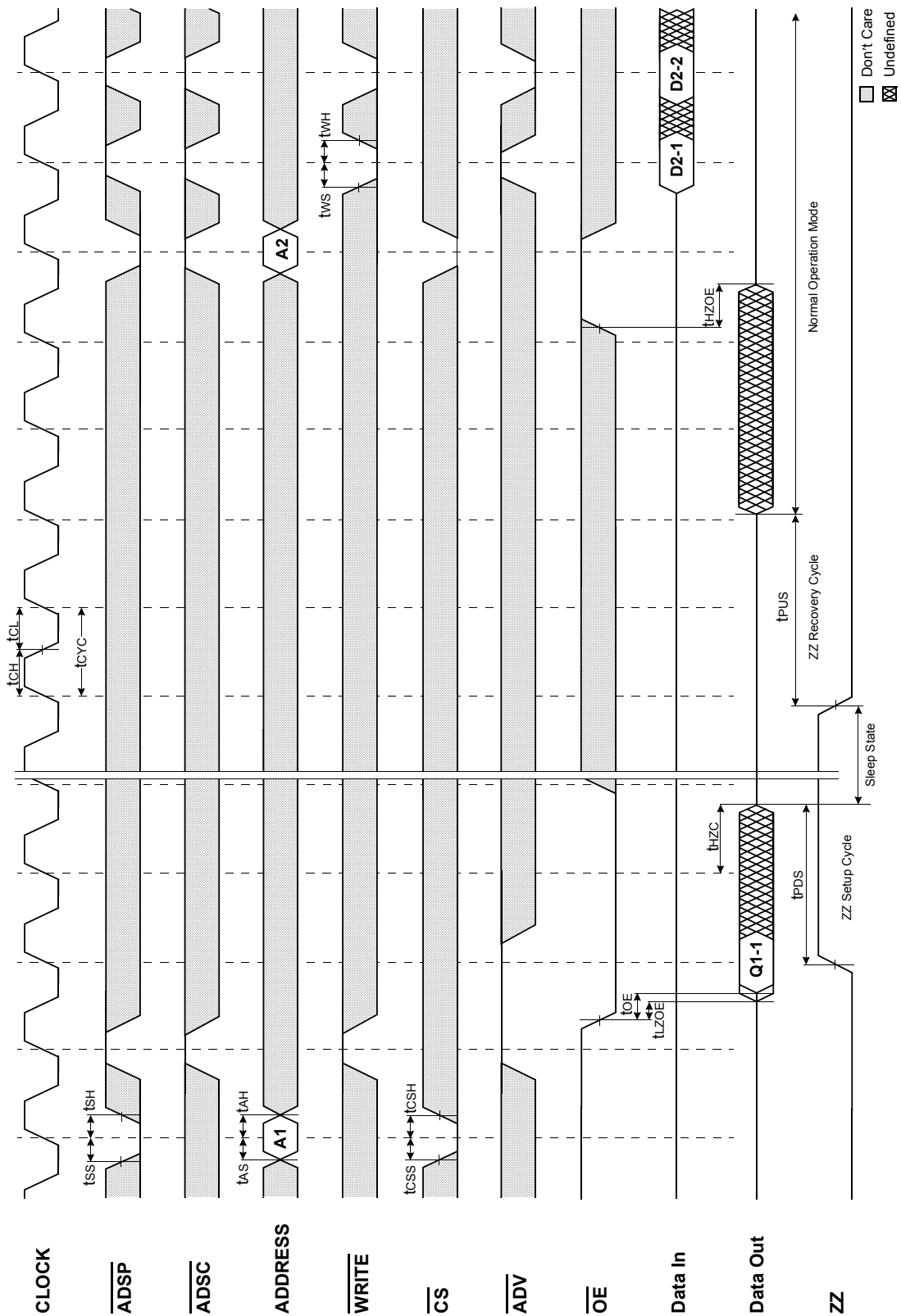

APPLICATION INFORMATION

DEPTH EXPANSION

The Samsung 128Kx36 Synchronous Pipelined Burst SRAM has two additional chip selects for simple depth expansion. This permits easy secondary cache upgrades from 128K depth to 256K depth without extra logic.

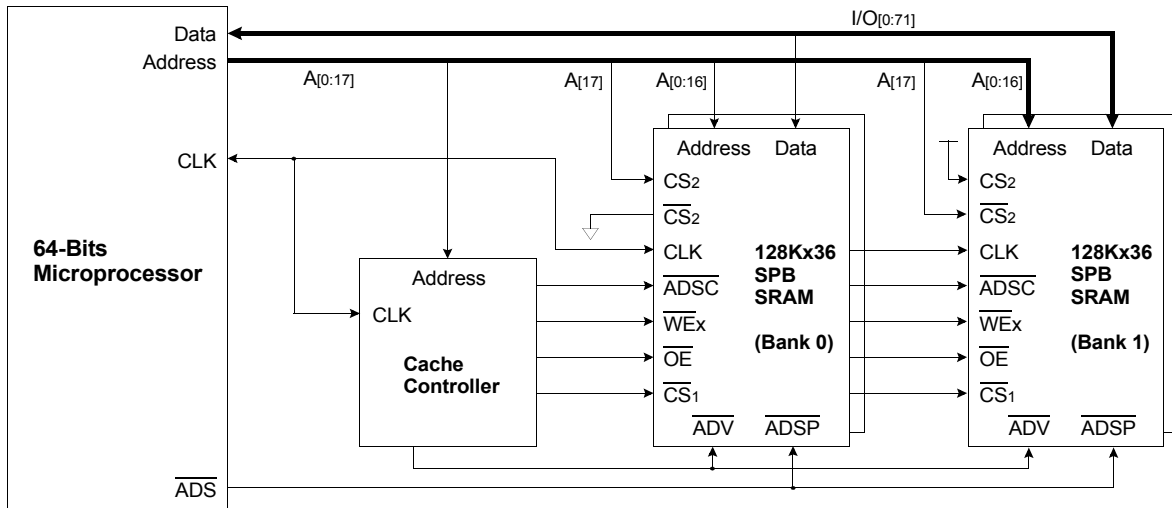

INTERLEAVE READ TIMING (Refer to non-interleave write timing for interleave write timing)

(ADSP CONTROLLED, ADSC=HIGH)

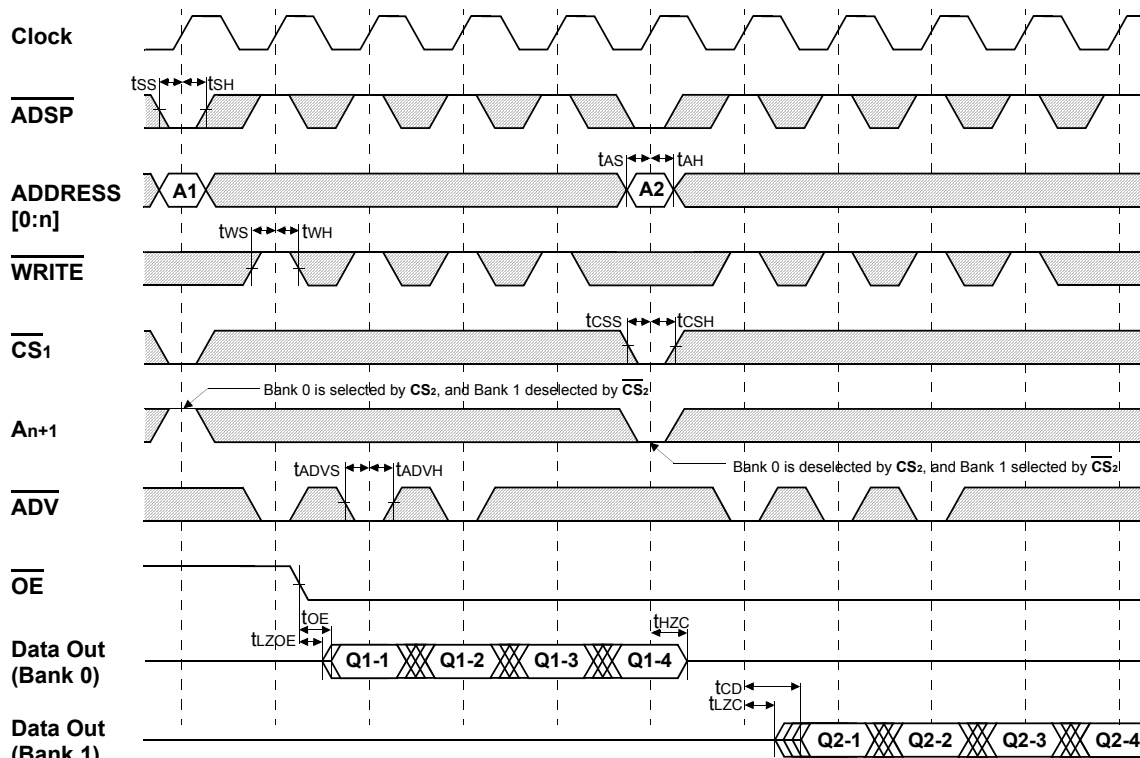

*Notes: n = 14 32K depth
15 64K depth
16 128K depth
17 256K depth

□ Don't Care ⊗ Undefined

APPLICATION INFORMATION

DEPTH EXPANSION

The Samsung 256Kx18 Synchronous Pipeline Burst SRAM has two additional chip selects for simple depth expansion. This permits easy secondary cache upgrades from 256K depth to 512K depth without extra logic.

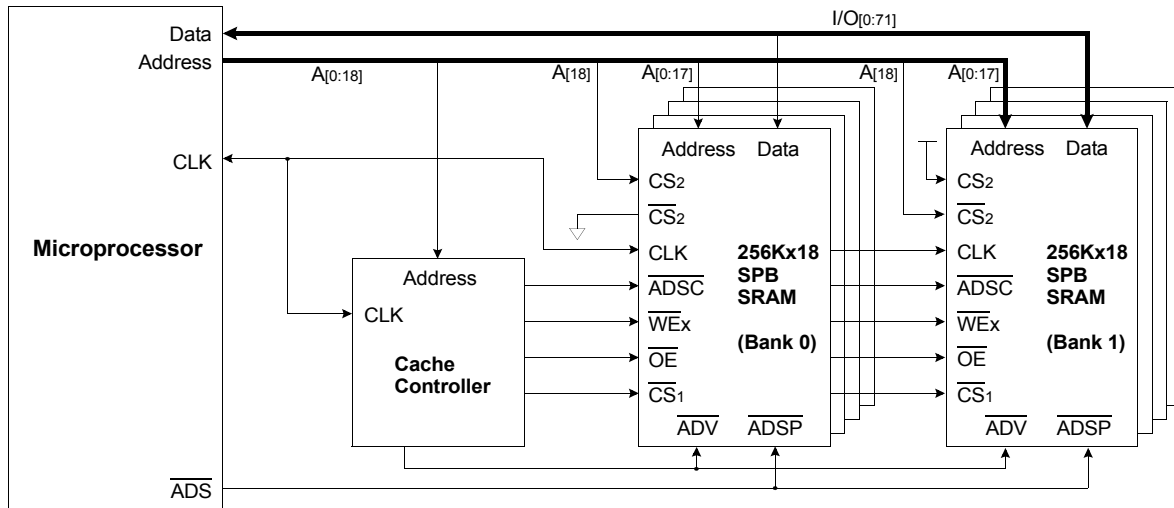

INTERLEAVE READ TIMING (Refer to non-interleave write timing for interleave write timing)

(ADSP CONTROLLED, ADSC=HIGH)

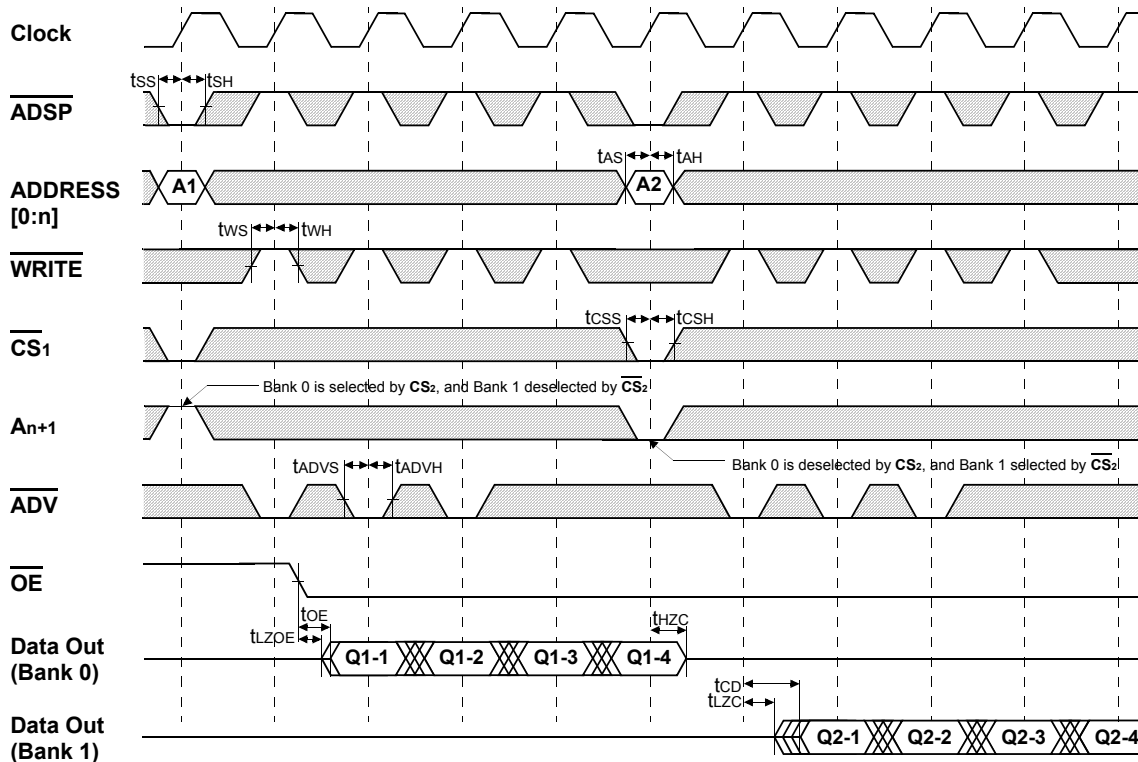

*Notes: n = 14 32K depth, 15 64K depth, 16 128K depth, 17 256K depth

□ Don't Care ⊗ Undefined

K7A403600B
K7A403200B
K7A401800B

128Kx36/x32 & 256Kx18 Synchronous SRAM

PACKAGE DIMENSIONS

100-TQFP-1420A

Units ; millimeters/Inches

