



# SAA7114

PAL/NTSC/SECAM video decoder with adaptive PAL/NTSC comb filter, VBI data slicer and high performance scaler

Rev. 03 — 17 January 2006

Product data sheet

## 1. General description

---

The SAA7114 is a video capture device for applications at the image port of Video Graphics Array (VGA) controllers.

The SAA7114 is a combination of a two-channel analog preprocessing circuit including source selection, anti-aliasing filter and Analog-to-Digital Converter (ADC), an automatic clamp and gain control, a Clock Generation Circuit (CGC), a digital multistandard decoder containing two-dimensional chrominance/luminance separation by an adaptive comb filter and a high performance scaler, including variable horizontal and vertical up and downscaling and a brightness, contrast and saturation control circuit.

It is a highly integrated circuit for desktop video and similar applications. The decoder is based on the principle of line-locked clock decoding and is able to decode the color of PAL, SECAM and NTSC signals into ITU 601 compatible color component values. The SAA7114 accepts CVBS or S-video (Y/C) as analog inputs from TV or VCR sources, including weak and distorted signals. An expansion port (X port) for digital video (bidirectional half duplex, D1 compatible) is also supported to connect to MPEG or a video phone codec. At the so called image port (I port) the SAA7114 supports 8-bit or 16-bit wide output data with auxiliary reference data for interfacing to VGA controllers.

The target application for the SAA7114 is to capture and scale video images, to be provided as a digital video stream through the image port of a VGA controller, for display via the frame buffer of the VGA, or for capture to system memory.

In parallel the SAA7114 also incorporates provisions for capturing the serially coded data in the Vertical Blanking Interval (VBI) data. Two principal functions are available:

1. To capture raw video samples, after interpolation to the required output data rate, via the scaler
2. A versatile data slicer (data recovery) unit

The SAA7114 also incorporates field-locked audio clock generation. This function ensures that there is always the same number of audio samples associated with a field, or a set of fields. This prevents the loss of synchronization between video and audio during capture or playback.

The circuit is I<sup>2</sup>C-bus controlled (full write/read capability for all programming registers, bit rate up to 400 kbit/s).

## 2. Features

### 2.1 Video decoder

- Six analog inputs, internal analog source selectors, e.g.  $6 \times$  CVBS or ( $2 \times$  Y/C and  $2 \times$  CVBS) or ( $1 \times$  Y/C and  $4 \times$  CVBS)
- Two analog preprocessing channels in differential CMOS style inclusive built-in analog anti-alias filters
- Fully programmable static gain or Automatic Gain Control (AGC) for the selected CVBS or Y/C channel
- Automatic Clamp Control (ACC) for CVBS, Y and C
- Switchable white peak control
- Two 9-bit video CMOS ADCs, digitized CVBS or Y/C signals are available on the expansion port
- On-chip line-locked clock generation in accordance with "ITU 601"
- Digital Phase-Locked Loop (PLL) for synchronization and clock generation from all standards and non-standard video sources e.g. consumer grade VTR
- Requires only one crystal (32.11 MHz or 24.576 MHz) for all standards
- Horizontal and vertical sync detection
- Automatic detection of 50 Hz and 60 Hz field frequency, and automatic switching between PAL and NTSC standards
- Luminance and chrominance signal processing for PAL B, G, D, H, I and N, combination PAL N, PAL M, NTSC M, NTSC-Japan, NTSC 4.43 and SECAM
- Adaptive 2/4-line comb filter for two dimensional chrominance/luminance separation:
  - ◆ Increased luminance and chrominance bandwidth for all PAL and NTSC standards
  - ◆ Reduced cross color and cross luminance artefacts
- PAL delay line for correcting PAL phase errors
- Independent Brightness Contrast Saturation (BCS) adjustment for decoder part
- User programmable sharpness control
- Independent gain and offset adjustment for raw data path

### 2.2 Video scaler

- Horizontal and vertical downscaling and upscaling to randomly sized windows
- Horizontal and vertical scaling range: variable zoom to  $\frac{1}{64}$  (icon) (it should be noted that the H and V zoom are restricted by the transfer data rates)
- Anti-alias and accumulating filter for horizontal scaling
- Vertical scaling with linear phase interpolation and accumulating filter for anti-aliasing (6-bit phase accuracy)
- Horizontal phase correct up and downscaling for improved signal quality of scaled data, especially for compression and video phone applications, with 6-bit phase accuracy (1.2 ns step width)
- Two independent programming sets for scaler part, to define two 'ranges' per field or sequences over frames
- Fieldwise switching between decoder part and expansion port (X port) input
- Brightness, contrast and saturation controls for scaled outputs

## 2.3 VBI data decoder and slicer

- Versatile VBI data decoder, slicer, clock regeneration and byte synchronization e.g. for World Standard Teletext (WST), North American Broadcast Text System (NABTS), closed caption, Wide Screen Signalling (WSS), etc.

## 2.4 Audio clock generation

- Generation of a field-locked audio master clock to support a constant number of audio clocks per video field
- Generation of an audio serial and left/right (channel) clock signal

## 2.5 Digital I/O interfaces

- Real-time signal port (R port), inclusive continuous line-locked reference clock and real-time status information supporting RTC level 3.1 (refer to document "RTC Functional Specification" for details)
- Bidirectional expansion port (X port) with half duplex functionality (D1), 8-bit  $Y-C_B-C_R$ :
  - ◆ Output from decoder part, real-time and unscaled
  - ◆ Input to scaler part, e.g. video from MPEG decoder (extension to 16-bit possible)
- Video image port (I port) configurable for 8-bit data (extension to 16-bit possible) in master mode (own clock), or slave mode (external clock), with auxiliary timing and handshake signals
- Discontinuous data streams supported
- 32-word  $\times$  4-byte FIFO register for video output data
- 28-word  $\times$  4-byte FIFO register for decoded VBI data output
- Scaled 4 : 2 : 2, 4 : 1 : 1, 4 : 2 : 0, 4 : 1 : 0  $Y-C_B-C_R$  output
- Scaled 8-bit luminance only and raw CVBS data output
- Sliced, decoded VBI data output

## 2.6 Miscellaneous

- Power-on control
- 5 V tolerant digital inputs and I/O ports
- Software controlled power saving standby modes supported
- Programming via serial I<sup>2</sup>C-bus, full read back ability by an external controller, bit rate up to 400 kbit/s
- Boundary scan test circuit complies with the "IEEE Std. 1149.b1 - 1994"

## 3. Applications

- Desktop video
- Multimedia
- Digital television
- Image processing
- Video phone applications

## 4. Quick reference data

**Table 1: Quick reference data**

Symbol	Parameter	Conditions	Min	Typ	Max	Unit
V <sub>DDD</sub>	digital supply voltage		3.0	3.3	3.6	V
V <sub>DDA</sub>	analog supply voltage		3.1	3.3	3.5	V
T <sub>amb</sub>	ambient temperature		0	-	70	°C
P <sub>tot(A+D)</sub>	total power dissipation analog and digital part	CVBS mode	[1] -	0.45	-	W

[1] 8-bit image port output mode, expansion port is 3-stated.

## 5. Ordering information

**Table 2: Ordering information**

Type number	Package		
	Name	Description	Version
SAA7114E	LBGA156	plastic low profile ball grid array package; 156 balls; body 15 × 15 × 1.05 mm	SOT700-1
SAA7114H	LQFP100	plastic low profile quad flat package; 100 leads; body 14 × 14 × 1.4 mm	SOT407-1

6. Block diagram

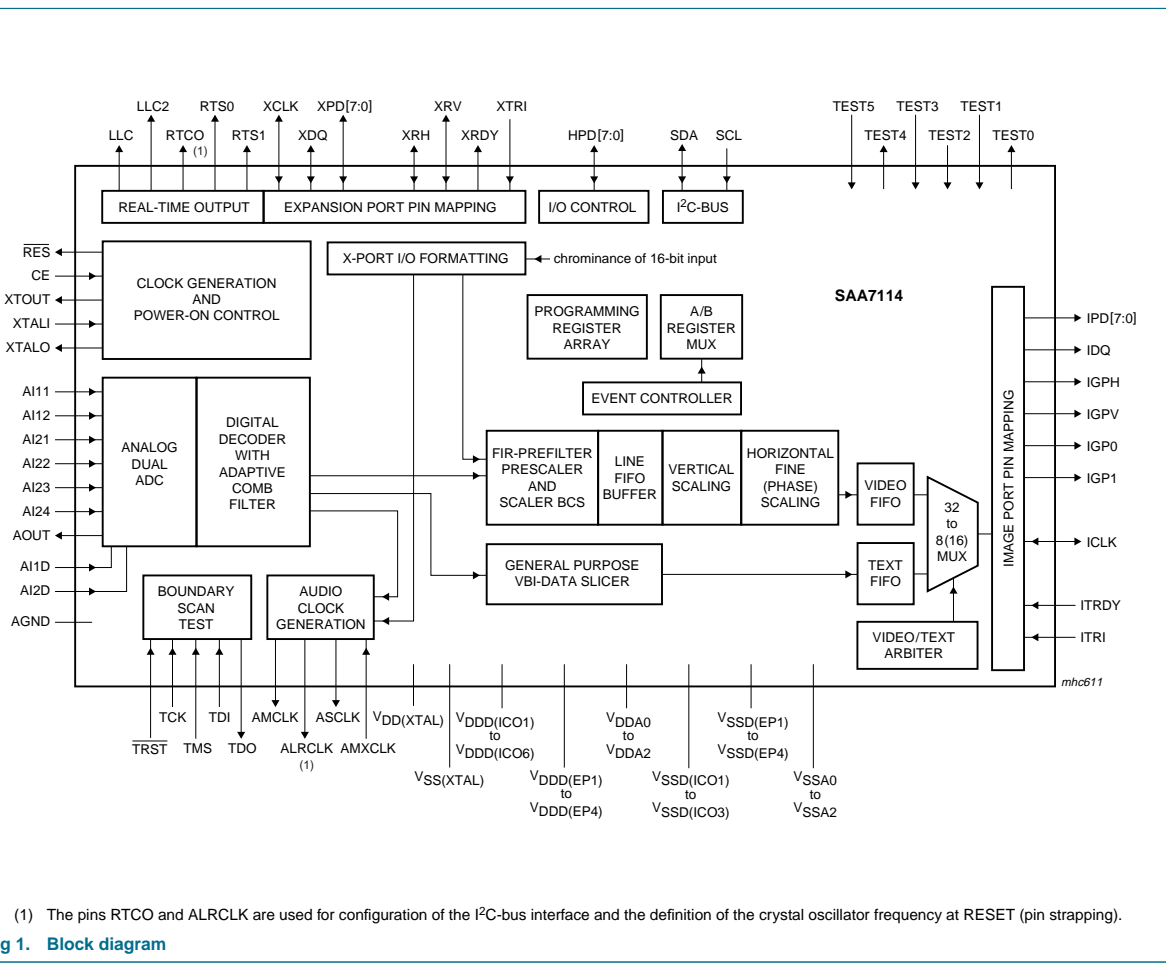

## 7. Pinning information

### 7.1 Pinning

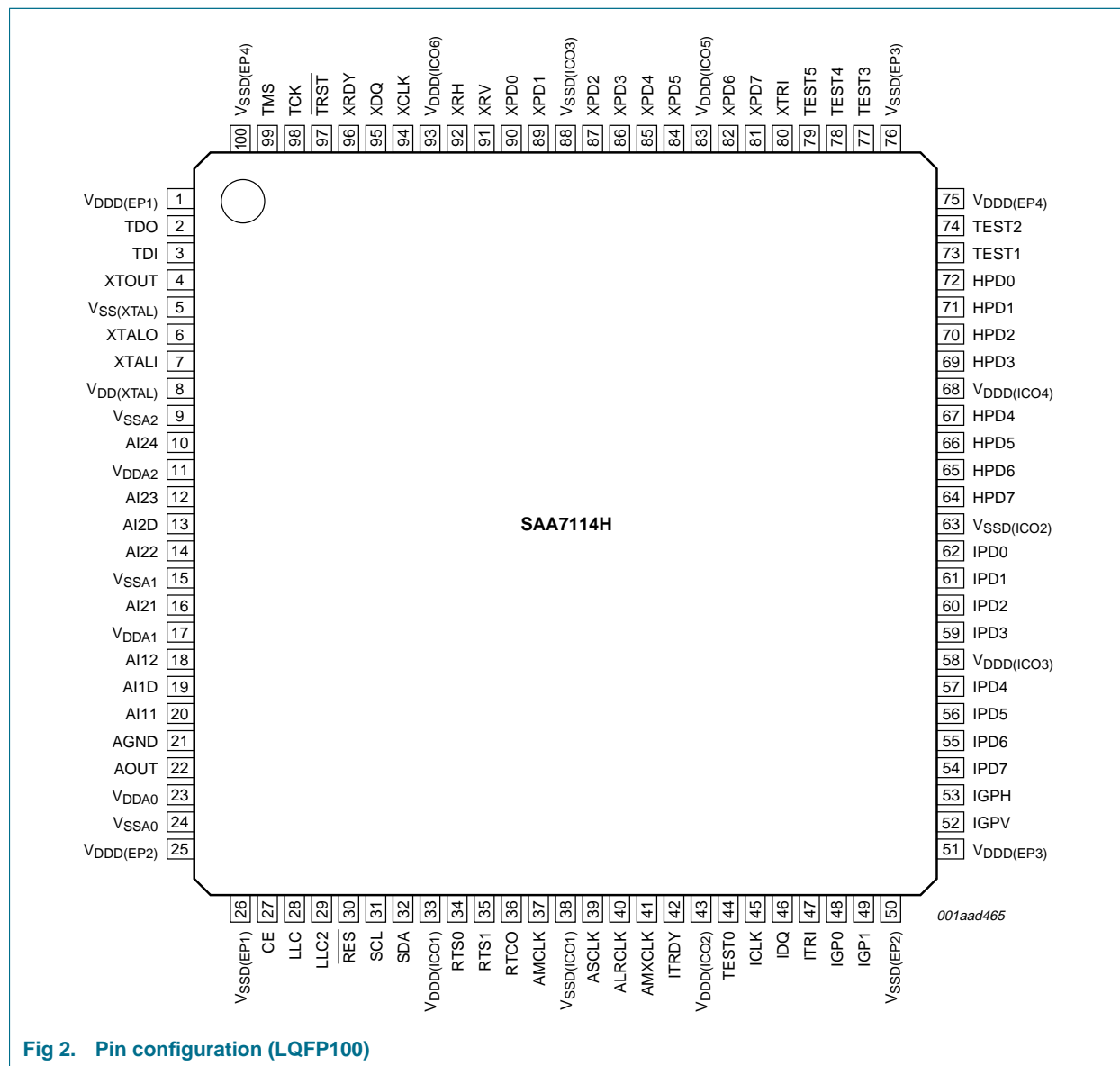

Fig 2. Pin configuration (LQFP100)

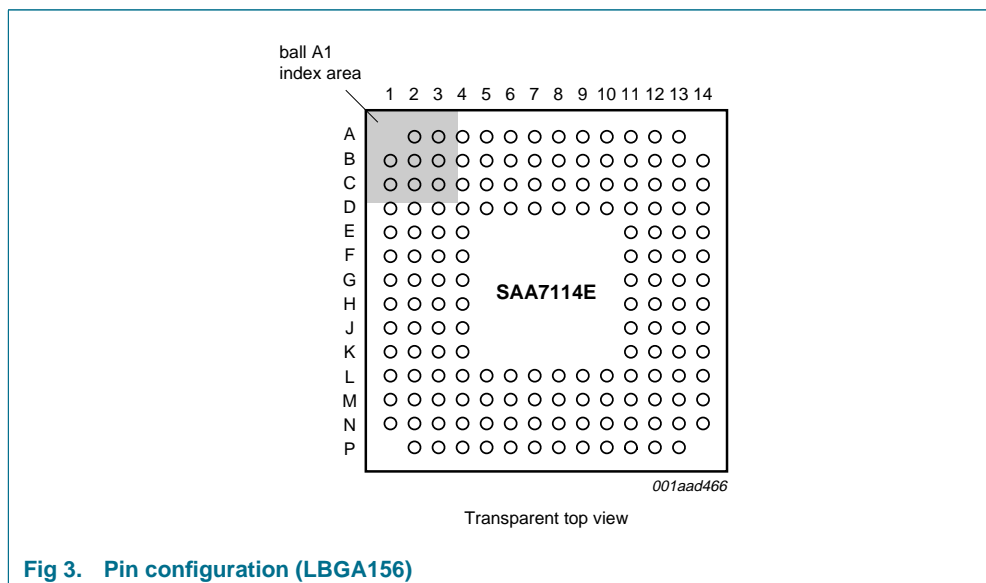

Fig 3. Pin configuration (LPGA156)

Table 3: Pin allocation table

Pin	Symbol	Pin	Symbol	Pin	Symbol	Pin	Symbol
A2	n.c.	A3	n.c.	A4	n.c.	A5	n.c.
A6	n.c.	A7	n.c.	A8	n.c.	A9	n.c.
A10	n.c.	A11	HPD0	A12	HPD3	A13	HPD7
B1	n.c.	B2	n.c.	B3	n.c.	B4	n.c.
B5	n.c.	B6	n.c.	B7	n.c.	B8	n.c.
B9	n.c.	B10	TEST1	B11	HPD1	B12	HPD4
B13	IPD0	B14	IPD4				
C1	n.c.	C2	n.c.	C3	n.c.	C4	n.c.
C5	n.c.	C6	n.c.	C7	n.c.	C8	n.c.
C9	n.c.	C10	TEST2	C11	HPD2	C12	HPD5
C13	IPD1	C14	IPD5				
D1	n.c.	D2	n.c.	D3	n.c.	D4	n.c.
D5	n.c.	D6	n.c.	D7	n.c.	D8	n.c.
D9	n.c.	D10	V <sub>DD</sub> (EP4)	D11	V <sub>DD</sub> (IC04)	D12	HPD6
D13	IPD2	D14	IPD6				
E1	n.c.	E2	n.c.	E3	n.c.	E4	n.c.
E11	V <sub>SSD</sub> (IC02)	E12	n.c.	E13	IPD3	E14	IPD7
F1	n.c.	F2	n.c.	F3	n.c.	F4	n.c.
F11	V <sub>DD</sub> (IC03)	F12	n.c.	F13	IGPV	F14	IGP0
G1	n.c.	G2	n.c.	G3	n.c.	G4	n.c.
G11	V <sub>DD</sub> (EP3)	G12	IGPH	G13	IGP1	G14	ITRI
H1	n.c.	H2	n.c.	H3	n.c.	H4	V <sub>SSD</sub> (EP3)
H11	V <sub>SSD</sub> (EP2)	H12	ICLK	H13	TEST0	H14	IDQ
J1	TEST4	J2	TEST5	J3	TEST3	J4	V <sub>DD</sub> (IC05)

Table 3: Pin allocation table ...continued

Pin	Symbol	Pin	Symbol	Pin	Symbol	Pin	Symbol
J11	V <sub>DD</sub> (IC02)	J12	AMXCLK	J13	ALRCLK	J14	ITRDY
K1	XTRI	K2	XPDP7	K3	XPDP6	K4	V <sub>SS</sub> (IC03)
K11	V <sub>SS</sub> (IC01)	K12	AMCLK	K13	RTS0	K14	ASCLK
L1	XPDP5	L2	XPDP4	L3	XPDP3	L4	V <sub>DD</sub> (IC06)
L5	XRV	L6	V <sub>SS</sub> (EP4)	L7	V <sub>DD</sub> (EP1)	L8	V <sub>DD</sub> (XTAL)
L9	V <sub>DD</sub> (EP2)	L10	RTS1	L11	V <sub>DD</sub> (IC01)	L12	SDA
L13	RTCO	L14	LLC2				
M1	XPDP2	M2	XPDP1	M3	XCLK	M4	XDQ
M5	TMS	M6	TCK	M7	V <sub>SSA2</sub>	M8	V <sub>DDA2</sub>
M9	V <sub>DDA1</sub>	M10	AOUT	M11	SCL	M12	$\overline{\text{RES}}$
M13	V <sub>SS</sub> (EP1)	M14	LLC				
N1	XPDP0	N2	XRH	N3	XRDY	N4	$\overline{\text{TRST}}$
N5	TDO	N6	TDI	N7	V <sub>SSA2</sub>	N8	V <sub>SSA1</sub>
N9	V <sub>SSA1</sub>	N10	AGND	N11	V <sub>DDA0</sub>	N12	V <sub>SSA0</sub>
N13	V <sub>SSA0</sub>	N14	CE				
P2	XTALI	P3	XTALO	P4	XTOUT	P5	V <sub>SS</sub> (XTAL)
P6	AI24	P7	AI23	P8	AI2D	P9	AI22
P10	AI21	P11	AI12	P12	AI1D	P13	AI11

## 7.2 Pin description

Table 4: Pin description

Symbol	Pin		Type <a href="#">[1]</a>	Description
	LQFP100	LBGA156		
V <sub>DD</sub> (EP1)	1	L7	P	external digital pad supply voltage 1 (3.3 V)
TDO	2	N5	O	test data output for boundary scan test <a href="#">[2]</a>
TDI	3	N6	I/pu	test data input for boundary scan test <a href="#">[2]</a>
XTOUT	4	P4	O	crystal oscillator output signal; auxiliary signal
V <sub>SS</sub> (XTAL)	5	P5	P	ground for crystal oscillator
XTALO	6	P3	O	24.576 MHz (32.11 MHz) crystal oscillator output; not connected if TTL clock input of XTALI is used
XTALI	7	P2	I	input terminal for 24.576 MHz (32.11 MHz) crystal oscillator or connection of external oscillator with TTL compatible square wave clock signal
V <sub>DD</sub> (XTAL)	8	L8	P	supply voltage for crystal oscillator
V <sub>SSA2</sub>	9	M7, N7	P	ground for analog inputs AI2n
AI24	10	P6	I	analog input 24
V <sub>DDA2</sub>	11	M8	P	analog supply voltage for analog inputs AI2n (3.3 V)
AI23	12	P7	I	analog input 23
AI2D	13	P8	I	differential input for ADC channel 2 (pins AI24, AI23, AI22 and AI21)
AI22	14	P9	I	analog input 22
V <sub>SSA1</sub>	15	N8, N9	P	ground for analog inputs AI1n
AI21	16	P10	I	analog input 21



Table 4: Pin description ...continued

Symbol	Pin		Type <sup>[1]</sup>	Description
	LQFP100	LBGA156		
V <sub>DDA1</sub>	17	-	P	analog supply voltage for analog inputs AI1n (3.3 V)
AI12	18	P11	I	analog input 12
AI1D	19	P12	I	differential input for ADC channel 1 (pins AI12 and AI11)
AI11	20	P13	I	analog input 11
AGND	21	N10	P	analog ground connection
AOUT	22	M10	O	do not connect; analog test output
V <sub>DDA0</sub>	23	N11	P	analog supply voltage (3.3 V) for internal Clock Generation Circuit (CGC)
V <sub>SSA0</sub>	24	N12, N13	P	ground for internal clock generation circuit
V <sub>DDD(EP2)</sub>	25	L9	P	external digital pad supply voltage 2 (3.3 V)
V <sub>SSD(EP1)</sub>	26	M13	P	external digital pad supply ground 1
CE	27	N14	I/pu	Chip Enable (CE) or reset input (with internal pull-up)
LLC	28	M14	O	line-locked system clock output (27 MHz nominal)
LLC2	29	L14	O	line-locked 1/2 clock output (13.5 MHz nominal)
RES	30	M12	O	reset output (active LOW)
SCL	31	M11	I/(O)	serial clock input (I <sup>2</sup> C-bus) with inactive output path
SDA	32	L12	I/O	serial data input/output (I <sup>2</sup> C-bus)
V <sub>DDD(IC01)</sub>	33	L11	P	internal digital core supply voltage 1 (3.3 V)
RTS0	34	K13	O	real-time status or sync information, controlled by subaddresses 11h and 12h; see <a href="#">Section 10.2.18</a> and <a href="#">Section 10.2.19</a>
RTS1	35	L10	O	real-time status or sync information, controlled by subaddresses 11h and 12h; see <a href="#">Section 10.2.18</a> and <a href="#">Section 10.2.19</a>
RTCO	36	L13	(I/O)	real-time control output; contains information about actual system clock frequency, field rate, odd/even sequence, decoder status, subcarrier frequency and phase and PAL sequence (see external document "RTC Functional Description", available on request); the RTCO pin <a href="#">[3]</a> <a href="#">[4]</a> is enabled via I <sup>2</sup> C-bus bit RTCE; see <a href="#">Table 58</a>
AMCLK	37	K12	O	audio master clock output, up to 50 % of crystal clock
V <sub>SSD(IC01)</sub>	38	K11	P	internal digital core supply ground 1
ASCLK	39	K14	O	audio serial clock output
ALRCLK	40	J13	(I/O)	audio left/right clock output; can be strapped <a href="#">[3]</a> <a href="#">[5]</a> to supply via a 3.3 kΩ resistor to indicate that the default 24.576 MHz crystal (pin ALRCLK = LOW; internal pull-down) has been replaced by a 32.110 MHz crystal (pin ALRCLK = HIGH)
AMXCLK	41	J12	I	audio master external clock input
ITRDY	42	J14	I/pu	target ready input, image port (with internal pull-up)
V <sub>DDD(IC02)</sub>	43	J11	P	internal digital core supply voltage 2 (3.3 V)
TEST0	44	H13	O	do not connect; reserved for future extensions and for testing: scan output
ICLK	45	H12	I/O	clock output signal for image port, or optional asynchronous back-end clock input
IDQ	46	H14	O	output data qualifier for image port (optional: gated clock output)
ITRI	47	G14	I/(O)	image port output control signal; selects all input port pins inclusive ICLK, enable and active polarity are under software control (bits IPE in subaddress 87h); output path used for testing: scan output

Table 4: Pin description ...continued

Symbol	Pin		Type <sup>[1]</sup>	Description
	LQFP100	LBGA156		
IGP0	48	F14	O	general purpose output signal 0; image port (controlled by subaddresses 84h and 85h)
IGP1	49	G13	O	general purpose output signal 1; image port (controlled by subaddresses 84h and 85h)
V <sub>SSD(EP2)</sub>	50	H11	P	external digital pad supply ground 2
V <sub>DDD(EP3)</sub>	51	G11	P	external digital pad supply voltage 3 (3.3 V)
IGPV	52	F13	O	multi purpose vertical reference output signal; image port (controlled by subaddresses 84h and 85h)
IGPH	53	G12	O	multi purpose horizontal reference output signal; image port (controlled by subaddresses 84h and 85h)
IPD7	54	E14	O	MSB of image port data output
IPD6	55	D14	O	MSB – 1 of image port data output
IPD5	56	C14	O	MSB – 2 of image port data output
IPD4	57	B14	O	MSB – 3 of image port data output
V <sub>DDD(IC03)</sub>	58	F11	P	internal digital core supply voltage 3 (3.3 V)
IPD3	59	E13	O	MSB – 4 of image port data output
IPD2	60	D13	O	MSB – 5 of image port data output
IPD1	61	C13	O	MSB – 6 of image port data output
IPD0	62	B13	O	LSB of image port data output
V <sub>SSD(IC02)</sub>	63	E11	P	internal digital core supply ground 2
HPD7	64	A13	I/O	MSB of host port data I/O, carries C <sub>B</sub> -C <sub>R</sub> chrominance information in 16-bit video I/O modes
HPD6	65	D12	I/O	MSB – 1 of host port data I/O, carries C <sub>B</sub> -C <sub>R</sub> chrominance information in 16-bit video I/O modes
HPD5	66	C12	I/O	MSB – 2 of host port data I/O, carries C <sub>B</sub> -C <sub>R</sub> chrominance information in 16-bit video I/O modes
HPD4	67	B12	I/O	MSB – 3 of host port data I/O, carries C <sub>B</sub> -C <sub>R</sub> chrominance information in 16-bit video I/O modes
V <sub>DDD(IC04)</sub>	68	D11	P	internal digital core supply voltage 4 (3.3 V)
HPD3	69	A12	I/O	MSB – 4 of host port data I/O, carries C <sub>B</sub> -C <sub>R</sub> chrominance information in 16-bit video I/O modes
HPD2	70	C11	I/O	MSB – 5 of host port data I/O, carries C <sub>B</sub> -C <sub>R</sub> chrominance information in 16-bit video I/O modes
HPD1	71	B11	I/O	MSB – 6 of host port data I/O, carries C <sub>B</sub> -C <sub>R</sub> chrominance information in 16-bit video I/O modes
HPD0	72	A11	I/O	LSB of host port data I/O, carries C <sub>B</sub> -C <sub>R</sub> chrominance information in 16-bit video I/O modes
TEST1	73	B10	I	do not connect; reserved for future extensions and for testing: scan input
TEST2	74	C10	I	do not connect; reserved for future extensions and for testing: scan input
V <sub>DDD(EP4)</sub>	75	D10	P	external digital pad supply voltage 4 (3.3 V)
V <sub>SSD(EP3)</sub>	76	H4	P	external digital pad supply ground 3
TEST3	77	J3	I	do not connect; reserved for future extensions and for testing: scan input
TEST4	78	J1	O	do not connect; reserved for future extensions and for testing: scan output

Table 4: Pin description ...continued

Symbol	Pin		Type <sup>[1]</sup>	Description
	LQFP100	LBGA156		
TEST5	79	J2	I	do not connect; reserved for future extensions and for testing: scan input
XTRI	80	K1	I	X port output control signal, affects all X port pins (XPD7 to XPD0, XRH, XRV, XDQ and XCLK), enable and active polarity is under software control (bits XPE in subaddress 83h)
XPD7	81	K2	I/O	MSB of expansion port data
XPD6	82	K3	I/O	MSB – 1 of expansion port data
V <sub>DDD(ICO5)</sub>	83	J4	P	internal digital core supply voltage 5 (3.3 V)
XPD5	84	L1	I/O	MSB – 2 of expansion port data
XPD4	85	L2	I/O	MSB – 3 of expansion port data
XPD3	86	L3	I/O	MSB – 4 of expansion port data
XPD2	87	M1	I/O	MSB – 5 of expansion port data
V <sub>SSD(ICO3)</sub>	88	K4	P	internal digital core supply ground 3
XPD1	89	M2	I/O	MSB – 6 of expansion port data
XPD0	90	N1	I/O	LSB of expansion port data
XRV	91	L5	I/O	vertical reference I/O expansion port
XRH	92	N2	I/O	horizontal reference I/O expansion port
V <sub>DDD(ICO6)</sub>	93	L4	P	internal digital core supply voltage 6 (3.3 V)
XCLK	94	M3	I/O	clock I/O expansion port
XDQ	95	M4	I/O	data qualifier I/O expansion port
XRDY	96	N3	O	task flag or ready signal from scaler, controlled by bit XRQT
$\overline{\text{TRST}}$	97	N4	I/pu	test reset input (active LOW), for boundary scan test <sup>[2]</sup> <sup>[6]</sup> <sup>[7]</sup>
TCK	98	M6	I/pu	test clock for boundary scan test <sup>[2]</sup>
TMS	99	M5	I/pu	test mode select input for boundary scan test or scan test <sup>[2]</sup>
V <sub>SSD(EP4)</sub>	100	L6	P	external digital pad supply ground 4

[1] I = input, O = output, P = power, pu = pull-up.

[2] In accordance with the "IEEE1149.1" standard the pins TDI, TMS, TCK and  $\overline{\text{TRST}}$  are input pins with an internal pull-up transistor and pin TDO is a 3-state output pin.

[3] Pin strapping is done by connecting the pin to the supply via a 3.3 k $\Omega$  resistor. During the power-up reset sequence the corresponding pins are switched to input mode to read the strapping level. For the default setting no strapping resistor is necessary (internal pull-down).

[4] Pin RTCO operates as I<sup>2</sup>C-bus slave address pin; pin RTCO = LOW for slave address 42h/43h (default); pin RTCO = HIGH for slave address 40h/41h.

[5] Pin ALRCLK = LOW for 24.576 MHz crystal (default); pin ALRCLK = HIGH for 32.110 MHz crystal.

[6] For board design without boundary scan implementation connect the  $\overline{\text{TRST}}$  pin to ground.

[7] This pin provides easy initialization of the Boundary Scan Test (BST) circuit. Pin  $\overline{\text{TRST}}$  can be used to force the Test Access Port (TAP) controller to the TEST\_LOGIC\_RESET state (normal operation) at once.

Table 5: 8-bit/16-bit and alternative pin function configurations

Pin [1]	Symbol	Input			Output			I/O configuration programming bits
		8-bit input modes	16-bit input modes (only for I <sup>2</sup> C-bus programming)	Alternative input functions	8-bit output modes	16-bit output modes (only for I <sup>2</sup> C-bus programming)	Alternative output functions	
K2, K3, L1 to L3, M1, M2, N1 (81, 82, 84 to 87, 89, 90)	XPD7 to XPD0	D1 data input	Y data input	-	D1 decoder output	-	-	XCODE[92h[3]], XPE[1:0] 83h[1:0] + pin XTRI
M3 (94)	XCLK	clock input	-	gated clock input	decoder clock output	-	-	XPE[1:0] 83h[1:0] + pin XTRI, XPCK[1:0] 83h[5:4], XCKS[92h[0]]
M4 (95)	XDQ	data qualifier input	-	-	data qualifier output (VREF and VREF gate)	-	-	XDQ[92h[1]], XPE[1:0] 83h[1:0] + pin XTRI
N3 (96)	XRDY	input ready output	-	active task A/B flag	-	-	-	XRQT[83h[2]], XPE[1:0] 83h[1:0] + pin XTRI
N2 (92)	XRH	horizontal reference input	-	-	decoder horizontal reference output	-	-	XDH[92h[2]], XPE[1:0] 83h[1:0] + pin XTRI
L5 (91)	XRV	vertical reference input	-	-	decoder vertical reference output	-	-	XDV[1:0] 92h[5:4], XPE[1:0] 83h[1:0] + pin XTRI
K1 (80)	XTRI	output enable input	-	-	-	-	-	XPE[1:0] 83h[1:0]
A13, D12, C12, B12, A12, C11, B11, A11 (64 to 67, 69 to 72)	HPD7 to HPD0	-	C <sub>B</sub> -C <sub>R</sub> data input	-	-	C <sub>B</sub> -C <sub>R</sub> scaler output	-	ICODE[93h[7]], ISWP[1:0] 85h[7:6], I8_16[93h[6]], IPE[1:0] 87h[1:0] + pin ITRI
E14, D14, C14, B14, E13, D13, C13, B13 (54 to 57, 59 to 62)	IPD7 to IPD0	-	-	-	D1 scaler output	Y scaler output	-	ICODE[93h[7]], ISWP[1:0] 85h[7:6], I8_16[93h[6]], IPE[1:0] 87h[1:0] + pin ITRI
H12 (45)	ICLK	-	-	-	clock output	-	clock input	ICKS[1:0] 80h[1:0], IPE[1:0] 87h[1:0] + pin ITRI
H14 (46)	IDQ	-	-	-	data qualifier output	-	gated clock output	ICKS[3:2] 80h[3:2], IDQP[85h[0]], IPE[1:0] 87h[1:0] + pin ITRI

Table 5: 8-bit/16-bit and alternative pin function configurations ...continued

Pin [1]	Symbol	Input			Output			I/O configuration programming bits
		8-bit input modes	16-bit input modes (only for I <sup>2</sup> C-bus programming)	Alternative input functions	8-bit output modes	16-bit output modes (only for I <sup>2</sup> C-bus programming)	Alternative output functions	
J14 (42)	ITRDY	-	-	-	target ready input	-	-	-
G12 (53)	IGPH	-	-	-	H gate output	-	extended H gate, horizontal pulses	IDH[1:0] 84h[1:0], IRHP[85h[1]], IPE[1:0] 87h[1:0] + pin ITRI
F13 (52)	IGPV	-	-	-	V gate output	-	V-sync, vertical pulses	IDV[1:0] 84h[3:2], IRVP[85h[2]], IPE[1:0] 87h[1:0] + pin ITRI
G13 (49)	IGP1	-	-	-	general purpose	-	-	IDG1[1:0] 84h[5:4], IG1P[85h[3]], IPE[1:0] 87h[1:0] + pin ITRI
F14 (48)	IGP0	-	-	-	general purpose	-	-	IDG0[1:0] 84h[7:6], IG0P[85h[4]], IPE[1:0] 87h[1:0] + pin ITRI
G14 (47)	ITRI	-	-	-	output enable input	-	-	-

[1] Pin numbers for LQFP100 in parenthesis.

## 8. Functional description

### 8.1 Decoder

#### 8.1.1 Analog input processing

The SAA7114 offers six analog signal inputs, two analog main channels with source switch, clamp circuit, analog amplifier, anti-alias filter and video 9-bit CMOS ADC; see [Figure 5](#).

#### 8.1.2 Analog control circuits

The anti-alias filters are adapted to the line-locked clock frequency via a filter control circuit. The characteristic is shown in [Figure 4](#). During the vertical blanking period gain and clamping control are frozen.

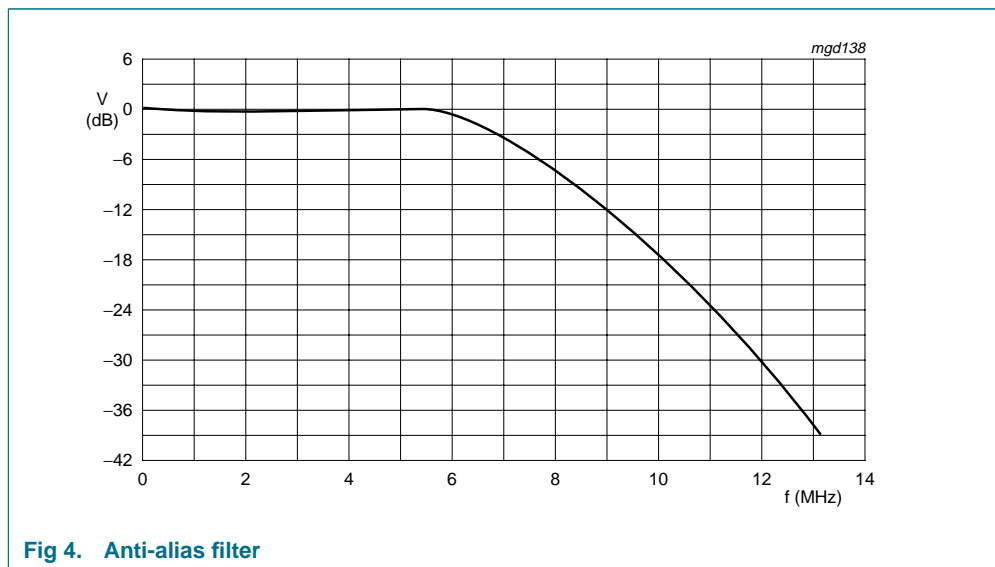

Fig 4. Anti-alias filter

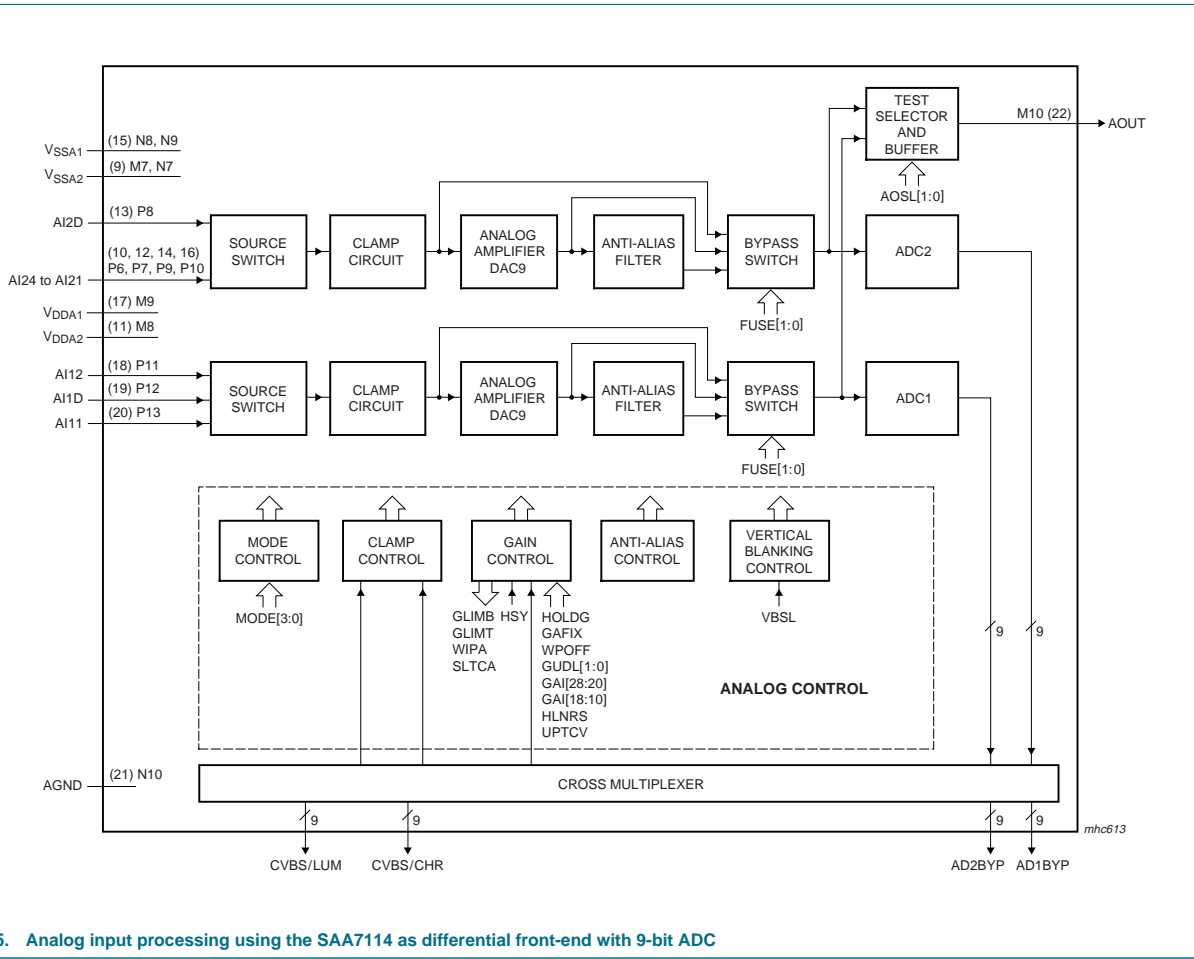

Fig 5. Analog input processing using the SAA7114 as differential front-end with 9-bit ADC

8.1.2.1 Clamping

The clamp control circuit controls the correct clamping of the analog input signals. The coupling capacitor is also used to store and filter the clamping voltage. An internal digital clamp comparator generates the information with respect to clamp-up or clamp-down. The clamping levels for the two ADC channels are fixed for luminance (60) and chrominance (128). Clamping time in normal use is set with the HCL pulse on the back porch of the video signal.

8.1.2.2 Gain control

The gain control circuit receives (via the I<sup>2</sup>C-bus) the static gain levels for the two analog amplifiers or controls one of these amplifiers automatically via a built-in Automatic Gain Control (AGC) as part of the Analog Input Control (AICO).

The AGC for luminance is used to amplify a CVBS or Y signal to the required signal amplitude, matched to the ADCs input voltage range. The AGC active time is the sync bottom of the video signal.

Signal (white) peak control limits the gain at signal overshoots. The flow charts (see [Figure 8](#) and [Figure 9](#)) show more details of the AGC. The influence of supply voltage variation within the specified range is automatically eliminated by clamp and automatic gain control.

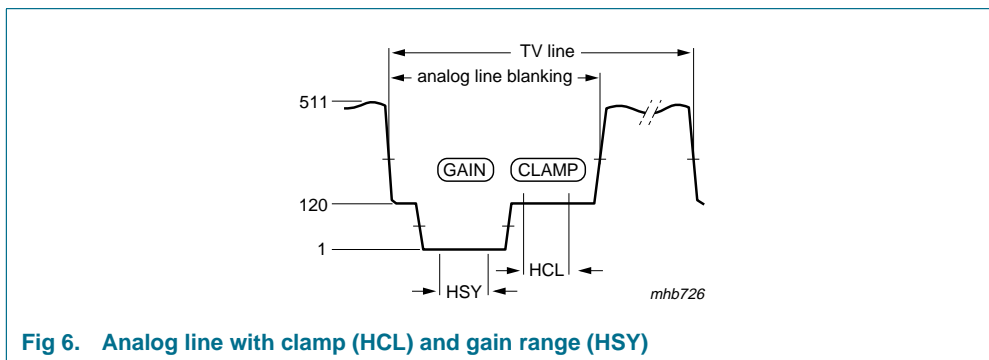

Fig 6. Analog line with clamp (HCL) and gain range (HSY)

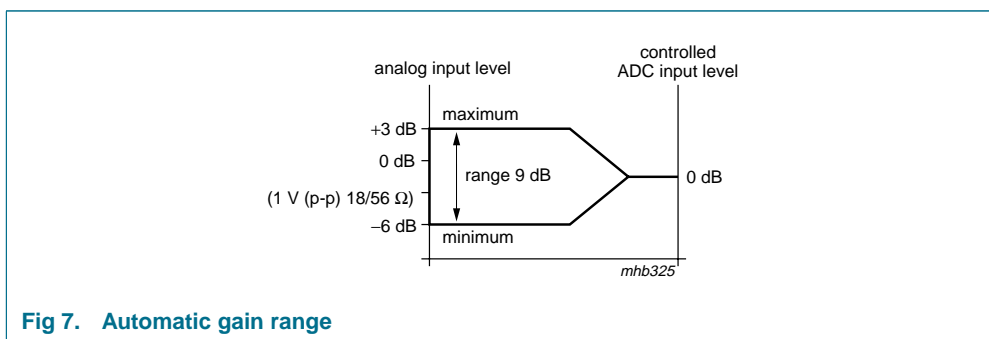
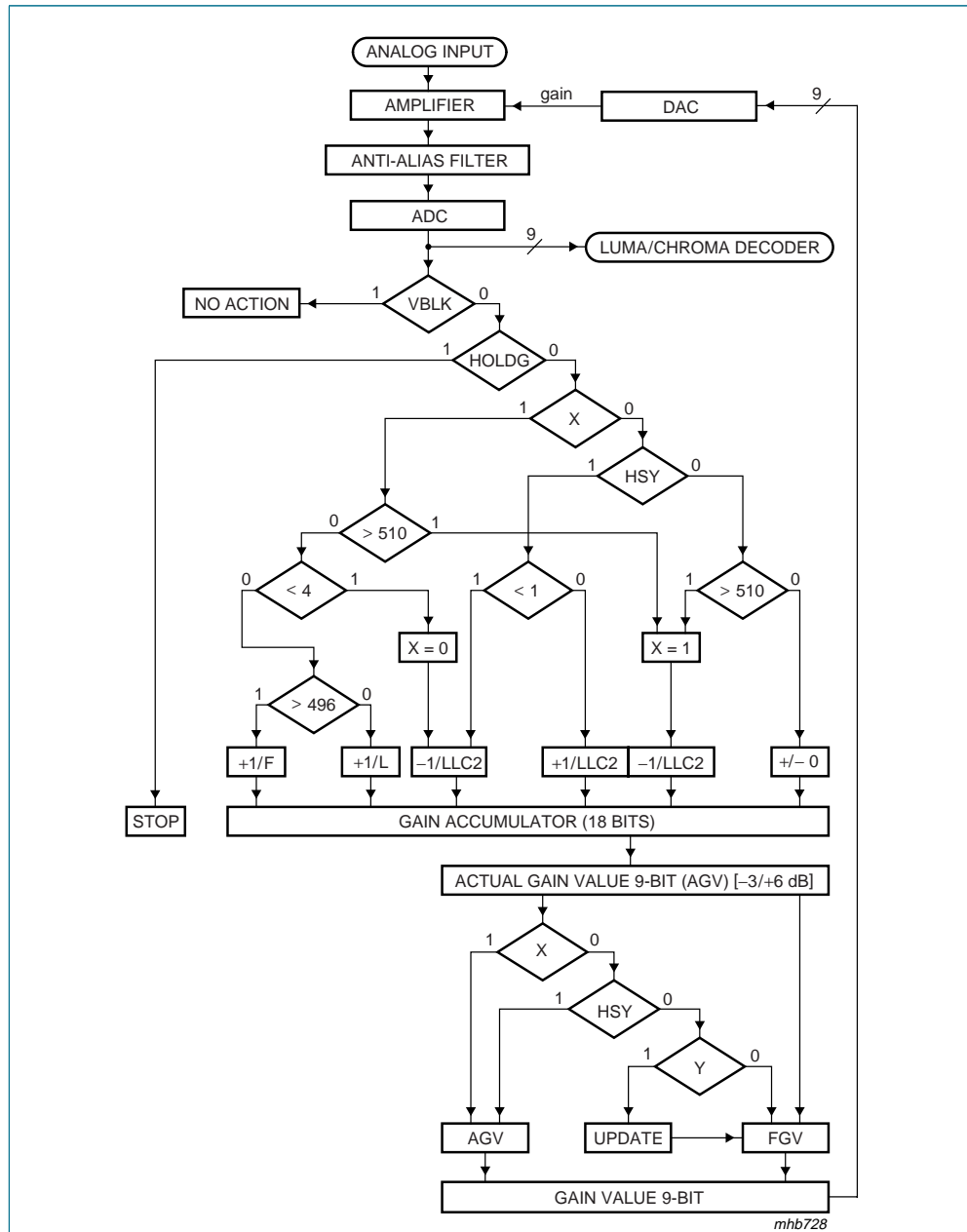

Fig 7. Automatic gain range





X = system variable.  
 Y =  $|AGV - FGV| > GUDL$ .  
 GUDL = gain update level (adjustable).  
 VBLK = vertical blanking pulse.  
 HSY = horizontal sync pulse.  
 AGV = actual gain value.  
 FGV = frozen gain value.

Fig 8. Gain flow chart

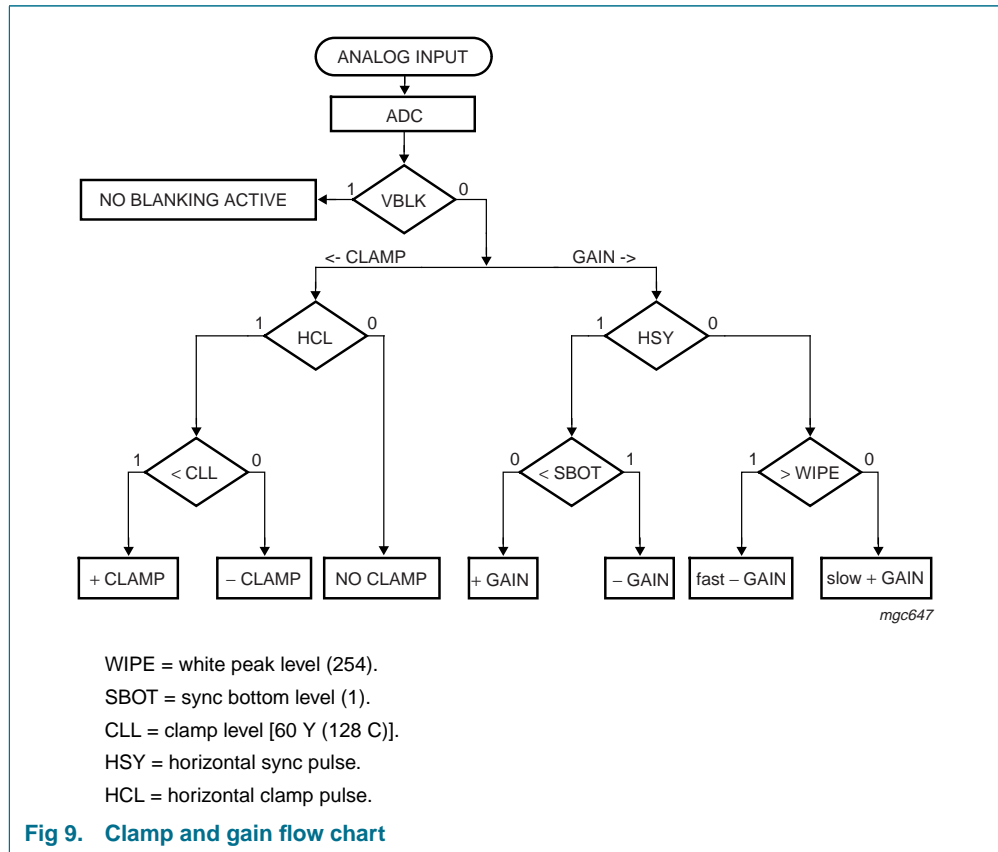

8.1.3 Chrominance and luminance processing

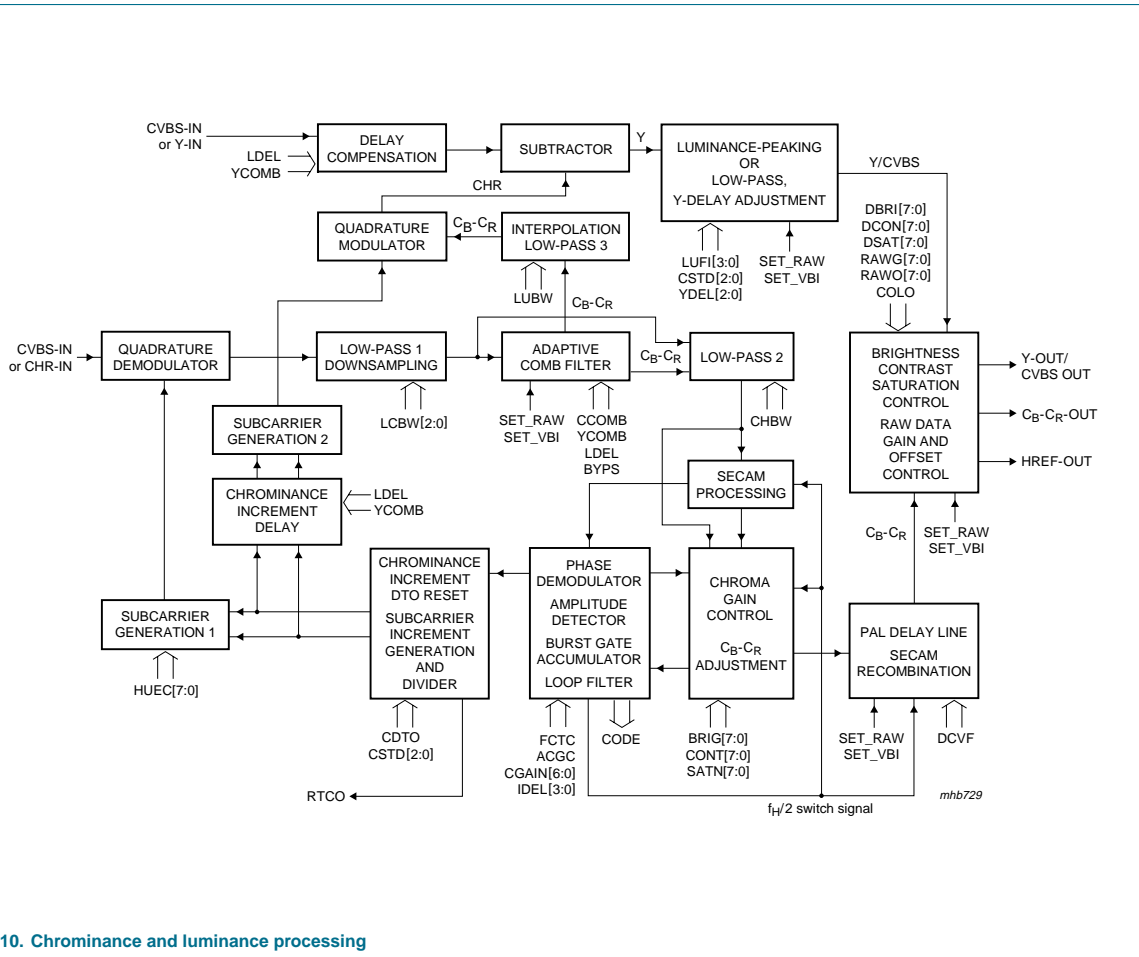

Fig 10. Chrominance and luminance processing

### 8.1.3.1 Chrominance path

The 9-bit CVBS or chrominance input signal is fed to the input of a quadrature demodulator, where it is multiplied by two time-multiplexed subcarrier signals from the subcarrier generation block 1 (0° and 90° phase relationship to the demodulator axis). The frequency is dependent on the chosen color standard.

The time-multiplexed output signals of the multipliers are low-pass filtered (low-pass 1). Eight characteristics are programmable via LCBW3 to LCBW0 to achieve the desired bandwidth for the color difference signals (PAL, NTSC) or the 0° and 90° FM signals (SECAM).

The chrominance low-pass 1 characteristic also influences the grade of cross luminance reduction during horizontal color transients (large chrominance bandwidth means strong suppression of cross luminance). If the Y-comb filter is disabled by YCOMB = 0 the filter influences directly the width of the chrominance notch within the luminance path (a large chrominance bandwidth means wide chrominance notch resulting in a lower luminance bandwidth).

The low-pass filtered signals are fed to the adaptive comb filter block. The chrominance components are separated from the luminance via a two-line vertical stage (four lines for PAL standards) and a decision logic between the filtered and the non-filtered output signals. This block is bypassed for SECAM signals. The comb filter logic can be enabled independently for the succeeding luminance and chrominance processing by YCOMB (subaddress 09h, bit D6) and/or CCOMB (subaddress 0Eh, bit D0). It is always bypassed during VBI or raw data lines programmable by the LCRn registers (subaddresses 41h to 57h); see [Section 8.2](#).

The separated  $C_B$ - $C_R$  components are further processed by a second filter stage (low-pass 2) to modify the chrominance bandwidth without influencing the luminance path. Its characteristic is controlled by CHBW (subaddress 10h, bit D3). For the complete transfer characteristic of low-passes 1 and 2, see [Figure 11](#) and [Figure 12](#).

The SECAM processing (bypassed for QAM standards) contains the following blocks:

- Baseband 'bell' filters to reconstruct the amplitude and phase equalized 0° and 90° FM signals
- Phase demodulator and differentiator (FM-demodulation)
- De-emphasis filter to compensate the pre-emphasized input signal, including frequency offset compensation (DB or DR white carrier values are subtracted from the signal, controlled by the SECAM switch signal)

The succeeding chrominance gain control block amplifies or attenuates the  $C_B$ - $C_R$  signal according to the required ITU 601/656 levels. It is controlled by the output signal from the amplitude detection circuit within the burst processing block.

The burst processing block provides the feedback loop of the chrominance PLL and contains the following:

- Burst gate accumulator
- Color identification and color killer
- Comparison nominal/actual burst amplitude (PAL/NTSC standards only)
- Loop filter chrominance gain control (PAL/NTSC standards only)

- Loop filter chrominance PLL (only active for PAL/NTSC standards)
- PAL/SECAM sequence detection, H/2-switch generation

The increment generation circuit produces the Discrete Time Oscillator (DTO) increment for both subcarrier generation blocks. It contains a division by the increment of the line-locked clock generator to create a stable phase-locked sine signal under all conditions (e.g. for non-standard signals).

The PAL delay line block eliminates crosstalk between the chrominance channels in accordance with the PAL standard requirements. For NTSC color standards the delay line can be used as an additional vertical filter. If desired, it can be switched off by  $DCVF = 1$ . It is always disabled during VBI or raw data lines programmable by the LCRn registers (subaddresses 41h to 57h); see [Section 8.2](#). The embedded line delay is also used for SECAM recombination (cross-over switches).

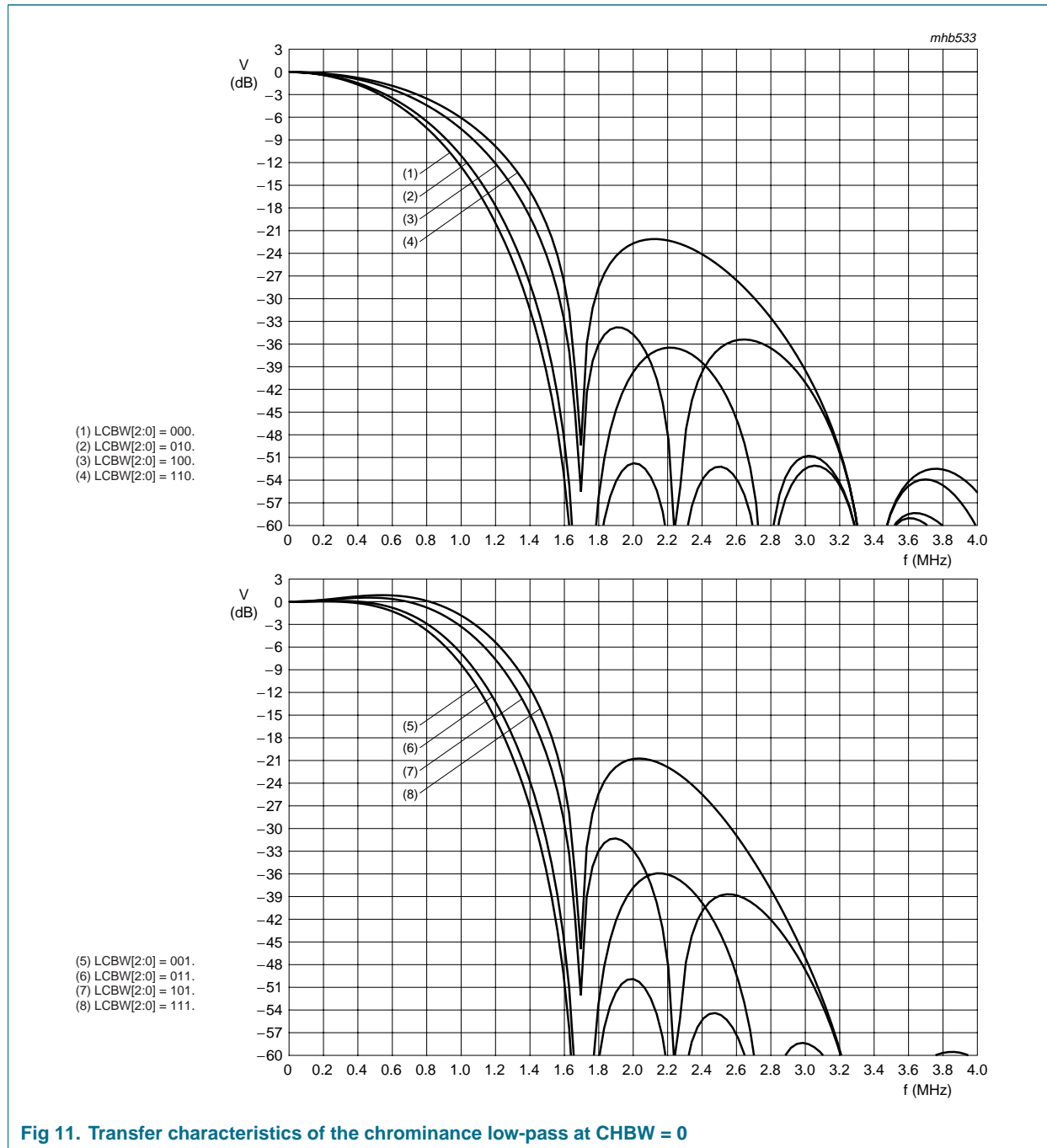

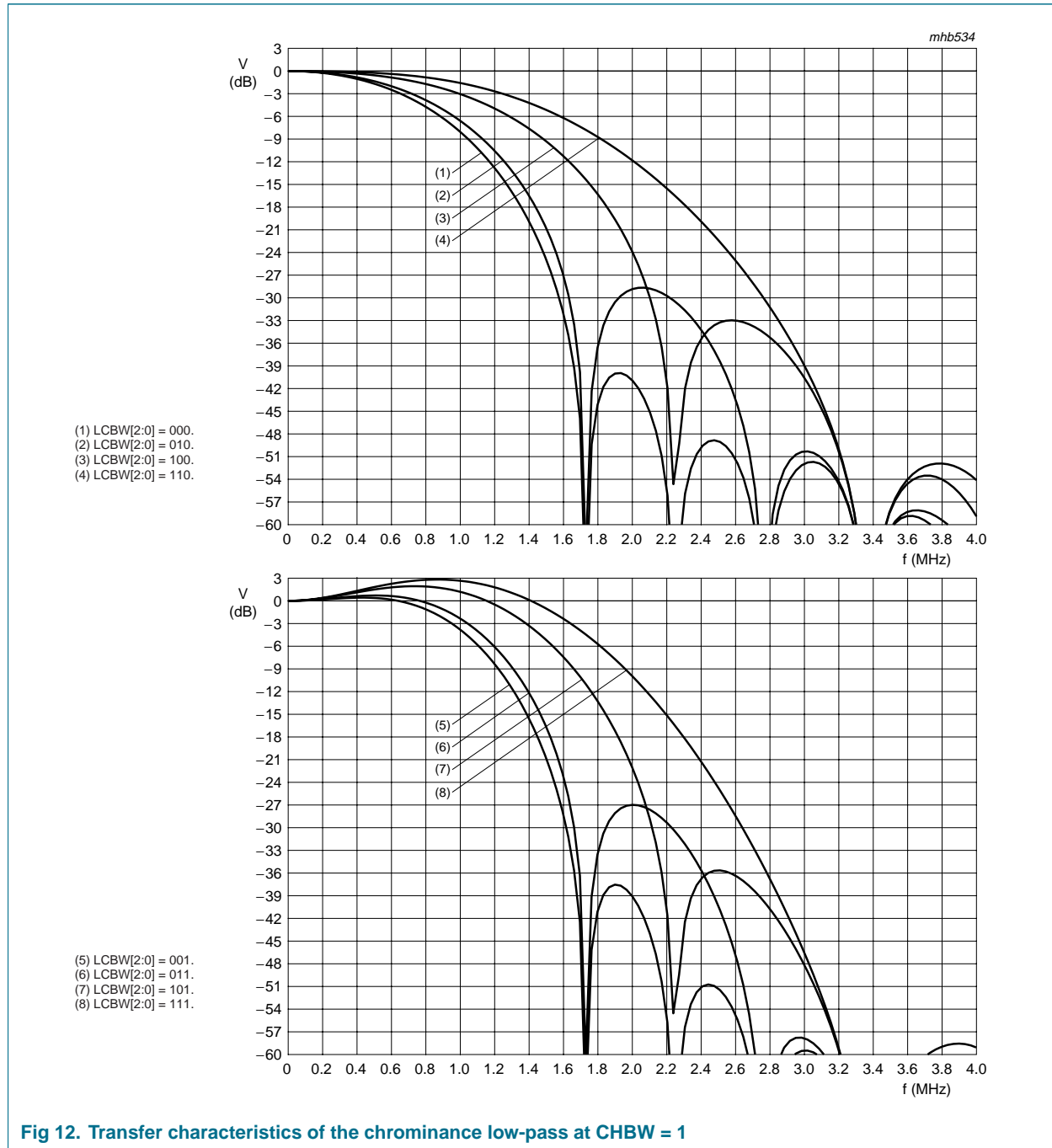

### 8.1.3.2 Luminance path

The rejection of the chrominance components within the 9-bit CVBS or Y input signal is achieved by subtracting the remodulated chrominance signal from the CVBS input.

The comb filtered  $C_B$ - $C_R$  components are interpolated (upsampled) by the low-pass 3 block. Its characteristic is controlled by LUBW (subaddress 09h, bit D4) to modify the width of the chrominance 'notch' without influencing the chrominance path. The programmable frequency characteristics available, in conjunction with the LCBW2 to LCBW0 settings, can be seen in [Figure 13](#) to [Figure 16](#). It should be noted that these frequency curves are only valid for Y-comb disabled filter mode (YCOMB = 0). In comb filter mode the frequency response is flat. The center frequency of the notch is automatically adapted to the chosen color standard.

The interpolated  $C_B$ - $C_R$  samples are multiplied by two time-multiplexed subcarrier signals from the subcarrier generation block 2. This second DTO is locked to the first subcarrier generator by an increment delay circuit matched to the processing delay, which is different for PAL and NTSC standards according to the chosen comb filter algorithm. The two modulated signals are finally added to build the remodulated chrominance signal.

The frequency characteristic of the separated luminance signal can be further modified by the succeeding luminance filter block. It can be configured as peaking (resolution enhancement) or low-pass block by LUF13 to LUF10 (subaddress 09h, bits D3 to D0). The 16 resulting frequency characteristics can be seen in [Figure 17](#). The LUF13 to LUF10 settings can be used as a user programmable sharpness control.

The luminance filter block also contains the adjustable Y-delay part; programmable by YDEL2 to YDEL0 (subaddress 11h, bits D2 to D0).



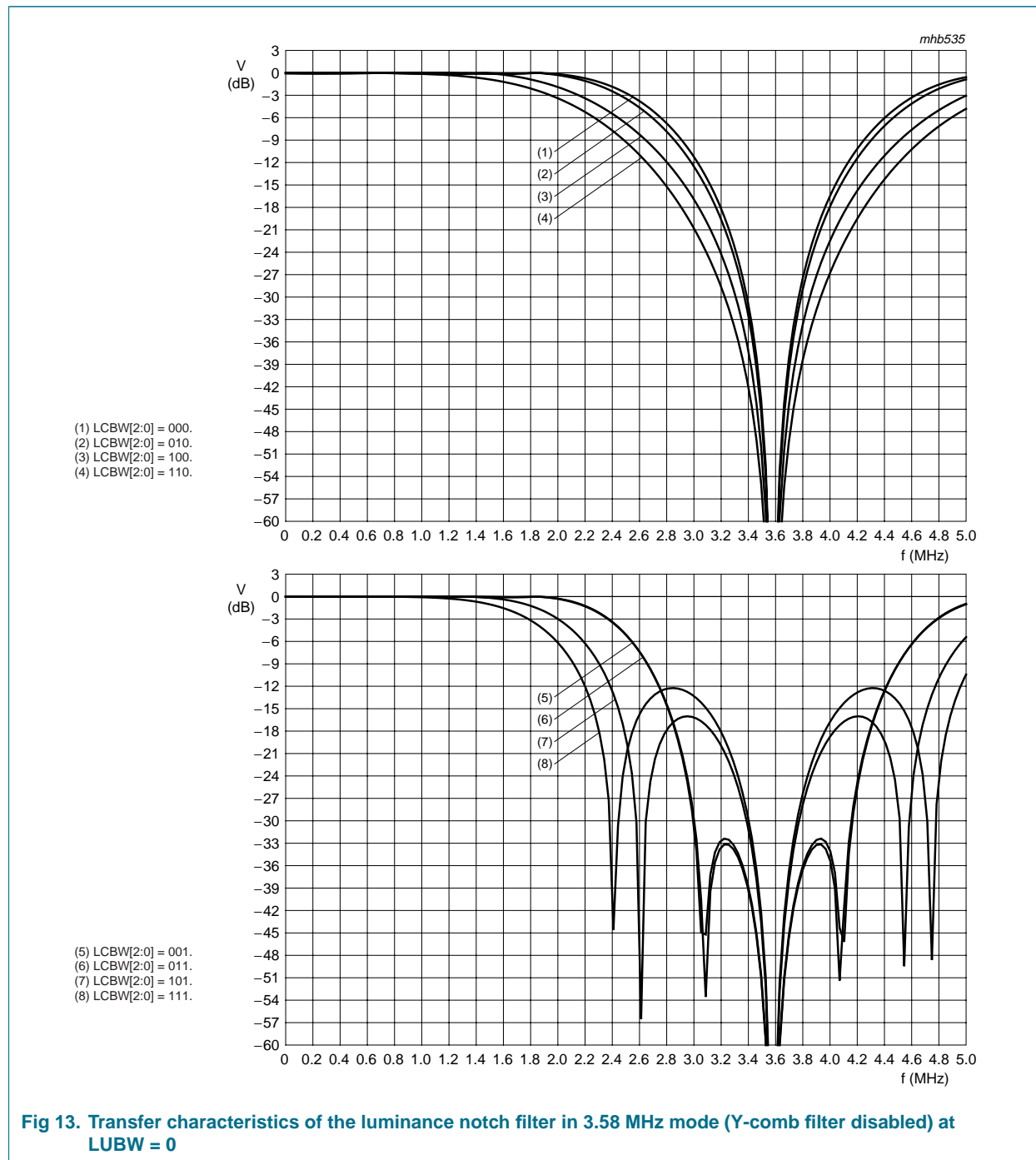

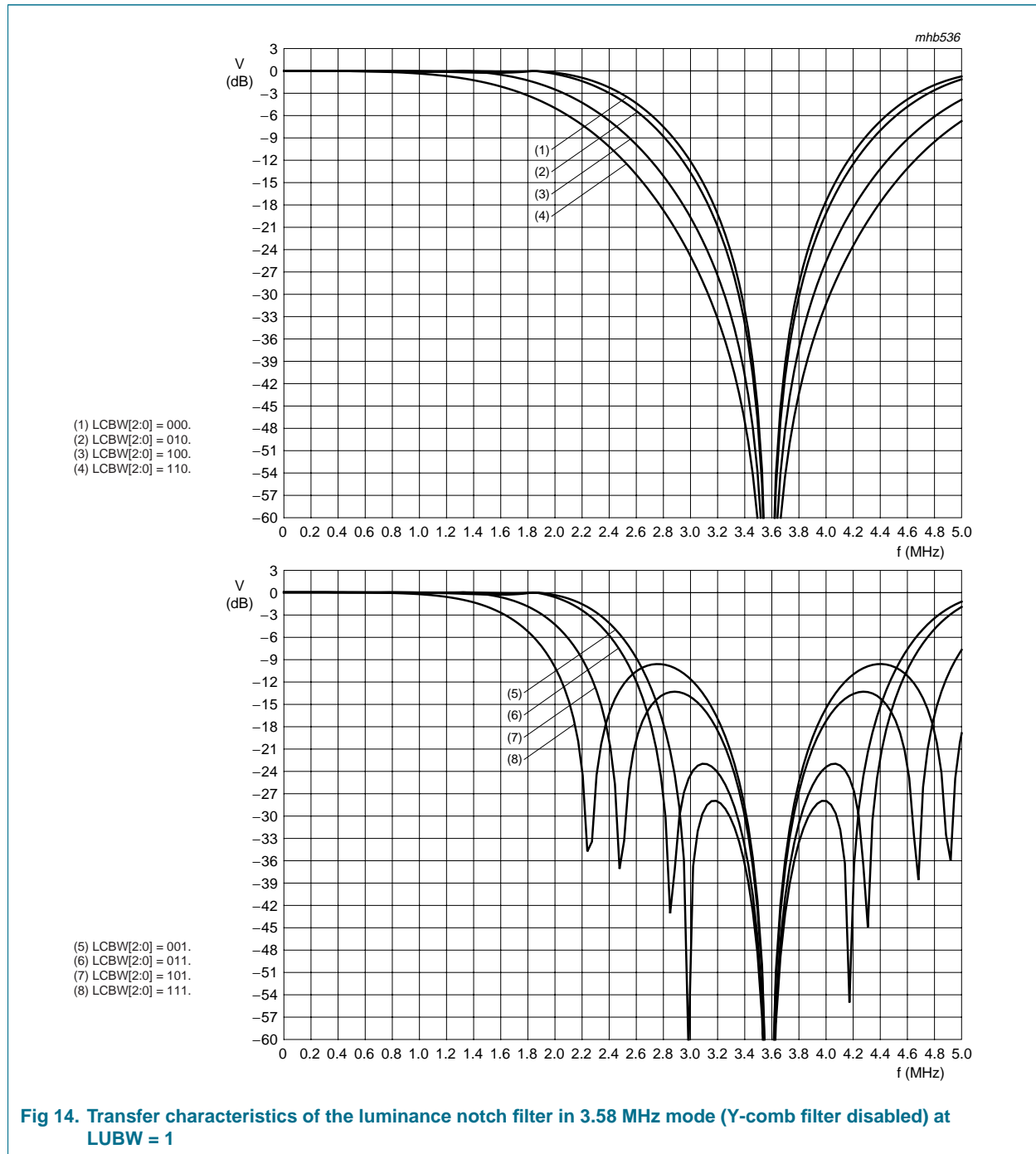

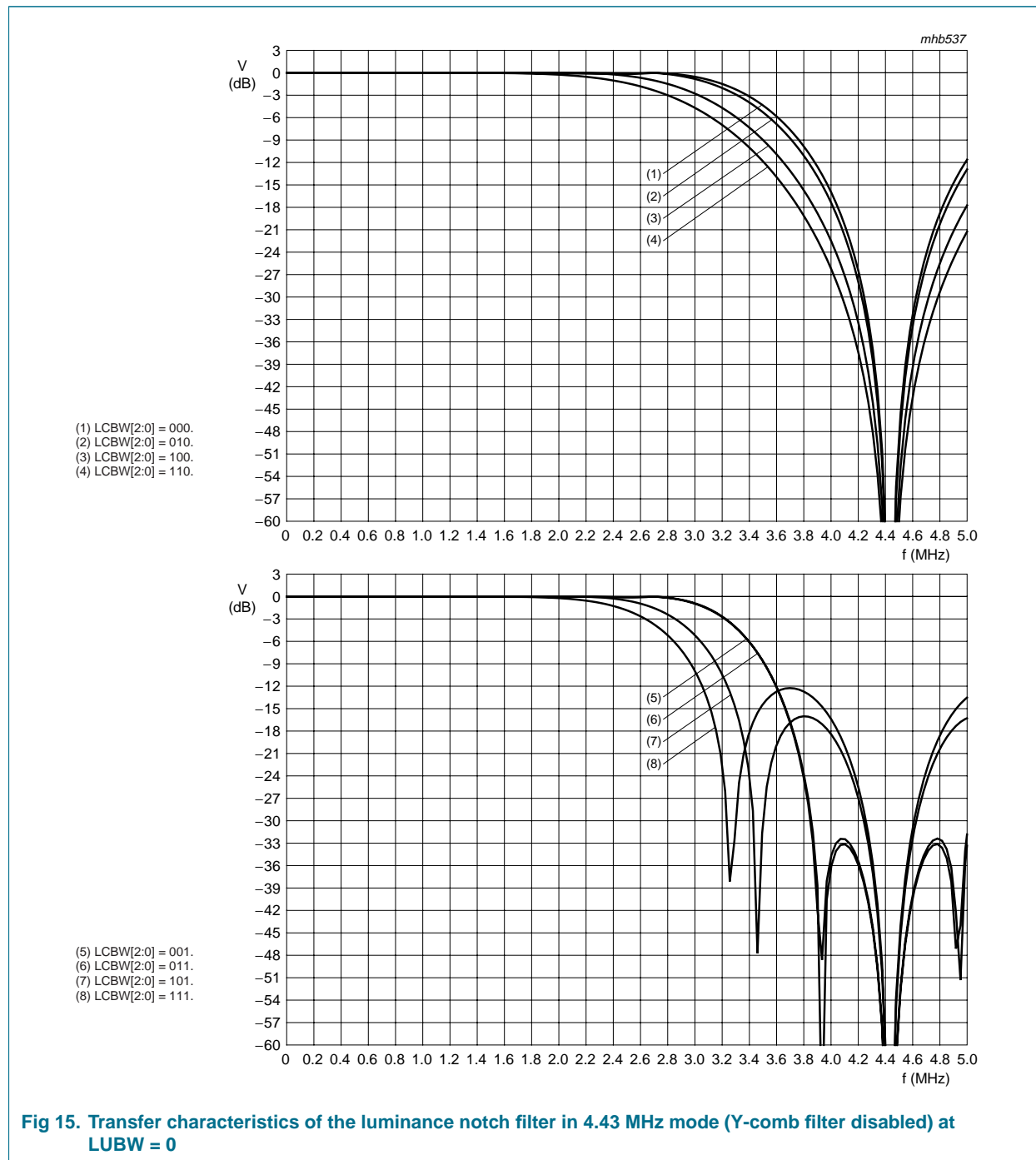

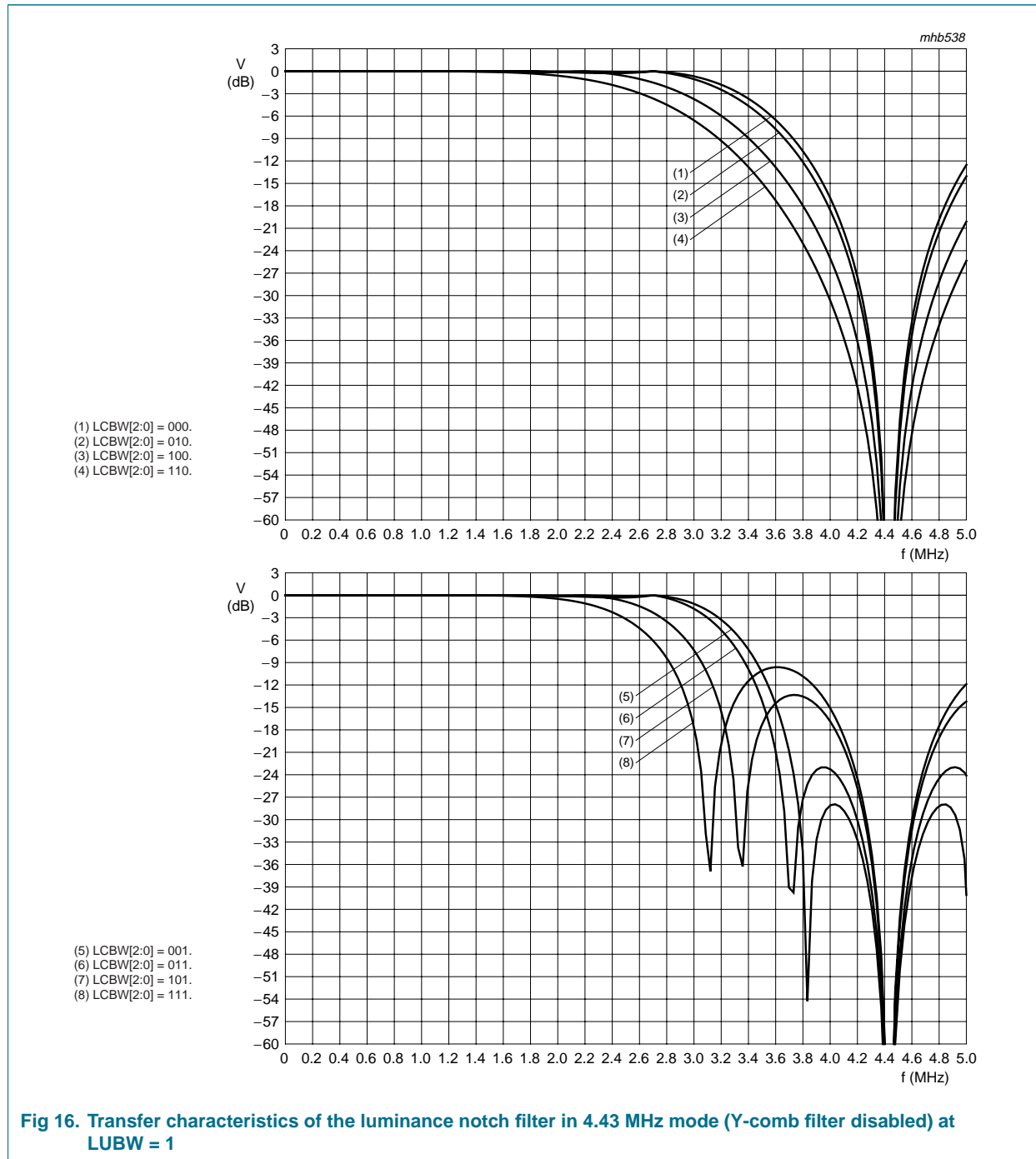

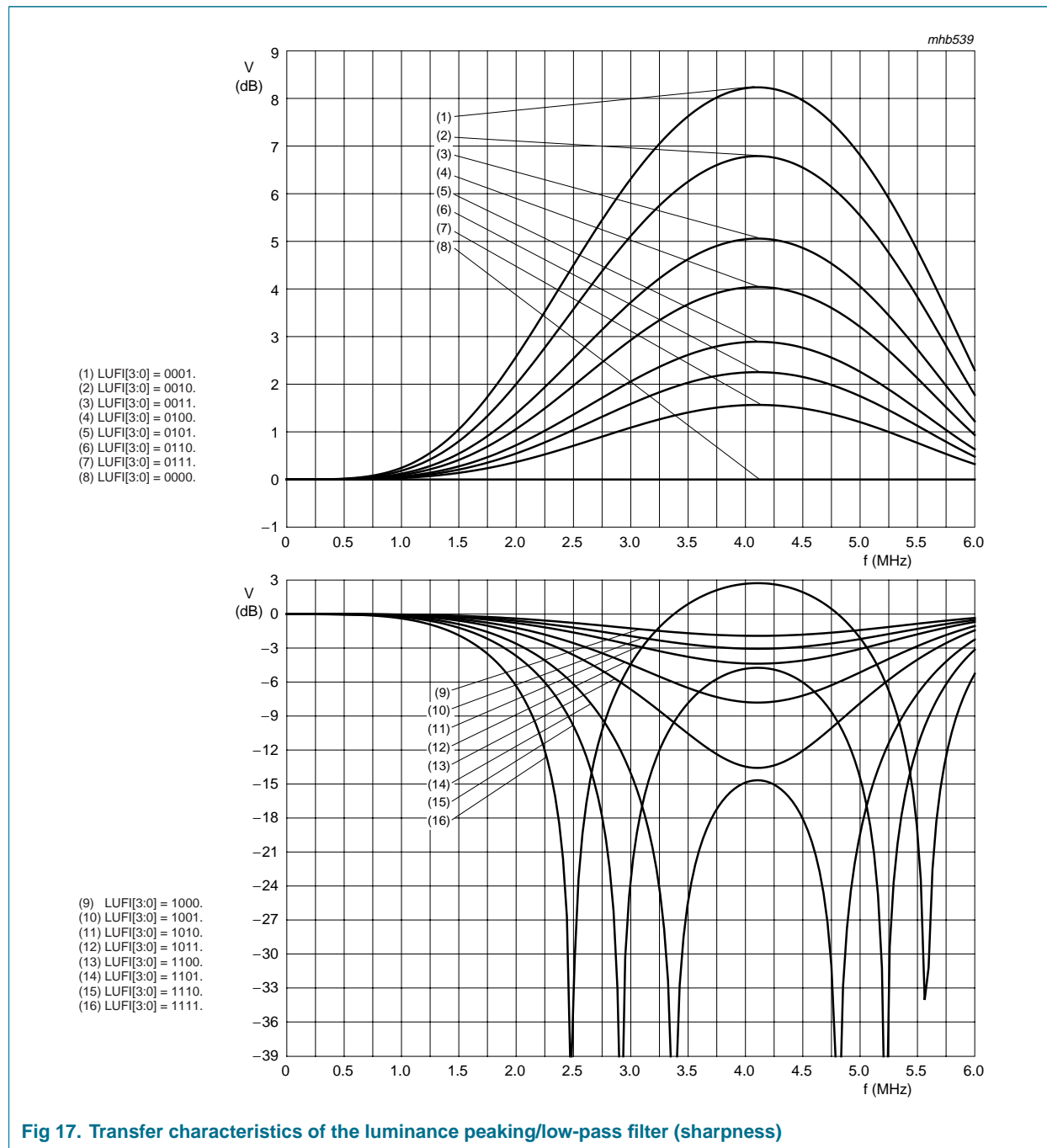

### 8.1.3.3 Brightness Contrast Saturation (BCS) control and decoder output levels

The resulting Y (CVBS) and  $C_B$ - $C_R$  signals are fed to the BCS block, which contains the following functions:

- Chrominance saturation control by DSAT7 to DSAT0
- Luminance contrast and brightness control by DCON7 to DCON0 and DBRI7 to DBRI0
- Raw data (CVBS) gain and offset adjustment by RAWG7 to RAWG0 and RAWO7 to RAWO0
- Limiting Y- $C_B$ - $C_R$  or CVBS to the values 1 (minimum) and 254 (maximum) to fulfil "ITU Recommendation 601/656".

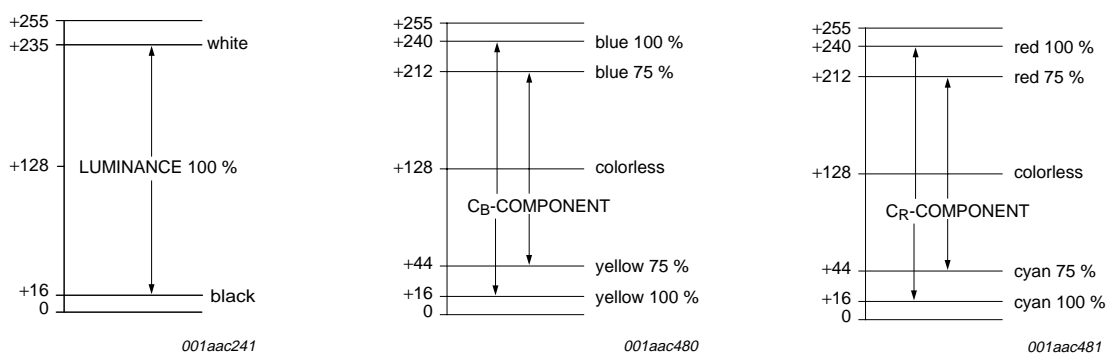

"ITU Recommendation 601/656" digital levels with default BCS (decoder) settings DCON[7:0] = 44h, DBRI[7:0] = 80h and DSAT[7:0] = 40h.

Equations for modification to the Y- $C_B$ - $C_R$  levels via BCS control I<sup>2</sup>C-bus bytes DBRI, DCON and DSAT.

$$\text{Luminance: } Y_{OUT} = \text{Int} \left[ \frac{DCON}{68} \times (Y - 128) \right] + DBRI$$

$$\text{Chrominance: } (C_R C_B)_{OUT} = \text{Int} \left[ \frac{DSAT}{64} \times (C_R, C_B - 128) \right] + 128$$

It should be noted that the resulting levels are limited to 1 to 254 in accordance with "ITU Recommendation 601/656".

- a. Y output range.                      b.  $C_B$  output range.                      c.  $C_R$  output range.

Fig 18. Y- $C_B$ - $C_R$  range for scaler input and X port output

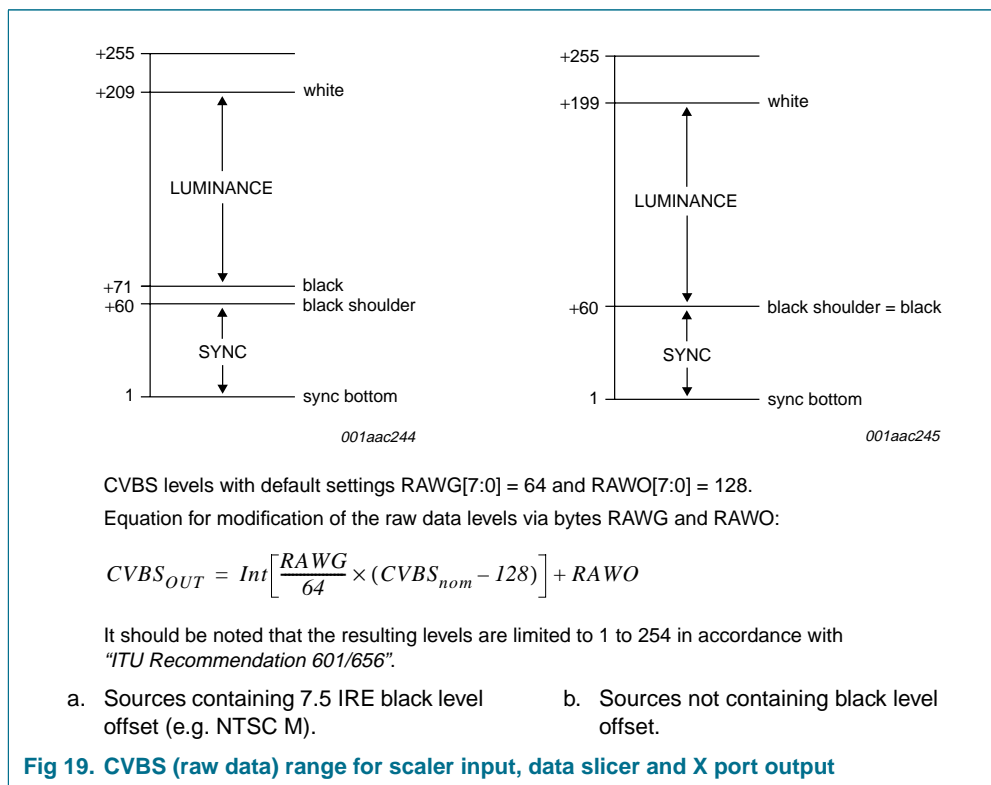

### 8.1.4 Synchronization

The prefiltered luminance signal is fed to the synchronization stage. Its bandwidth is further reduced to 1 MHz in a low-pass filter. The sync pulses are sliced and fed to the phase detectors where they are compared with the sub-divided clock frequency. The resulting output signal is applied to the loop filter to accumulate all phase deviations. Internal signals (e.g. HCL and HSY) are generated in accordance with analog front-end requirements. The loop filter signal drives an oscillator to generate the line frequency control signal LFCO; see [Figure 20](#).

The detection of 'pseudo syncs' as part of the Macrovision copy protection standard is also achieved within the synchronization circuit.

The result is reported as flag COPRO within the decoder status byte at subaddress 1Fh.

### 8.1.5 Clock generation circuit

The internal CGC generates all clock signals required for the video input processor.

The internal signal LFCO is a digital-to-analog converted signal provided by the horizontal PLL. It is the multiple of the line frequency:

- 6.75 MHz = 429 × f<sub>H</sub> (50 Hz), or
- 6.75 MHz = 432 × f<sub>H</sub> (60 Hz)

The LFCO signal is multiplied by a factor of 2 and 4 in the internal PLL circuit (including phase detector, loop filtering, VCO and frequency divider) to obtain the output clock signals. The rectangular output clocks have a 50 % duty factor.

Table 6: Decoder clock frequencies

Clock	Frequency (MHz)
XTALO	24.576 or 32.110
LLC	27
LLC2	13.5
LLC4 (internal)	6.75
LLC8 (virtual)	3.375

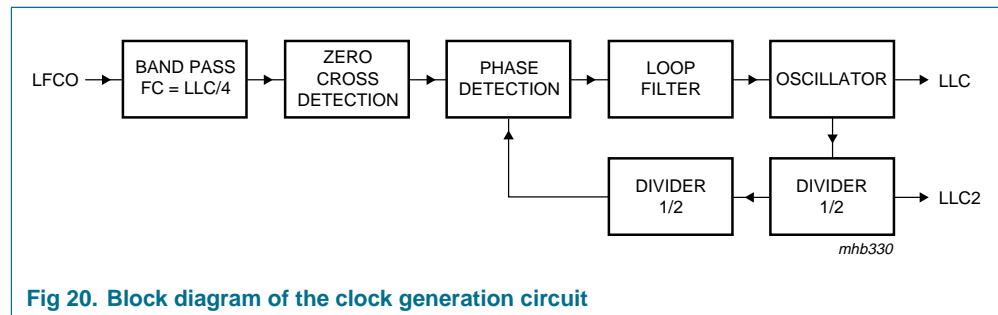

Fig 20. Block diagram of the clock generation circuit

### 8.1.6 Power-on reset and CE input

A missing clock, insufficient digital or analog  $V_{DDA0}$  supply voltages (below 2.7 V) will start the reset sequence; all outputs are forced to 3-state (see [Figure 21](#)). The indicator output  $\overline{RES}$  is LOW for approximately 128 LLC after the internal reset and can be applied to reset other circuits of the digital TV system.

It is possible to force a reset by pulling the CE input to ground. After the rising edge of CE and sufficient power supply voltage, the outputs LLC, LLC2 and SDA return from 3-state to active, while the other signals have to be activated via programming.



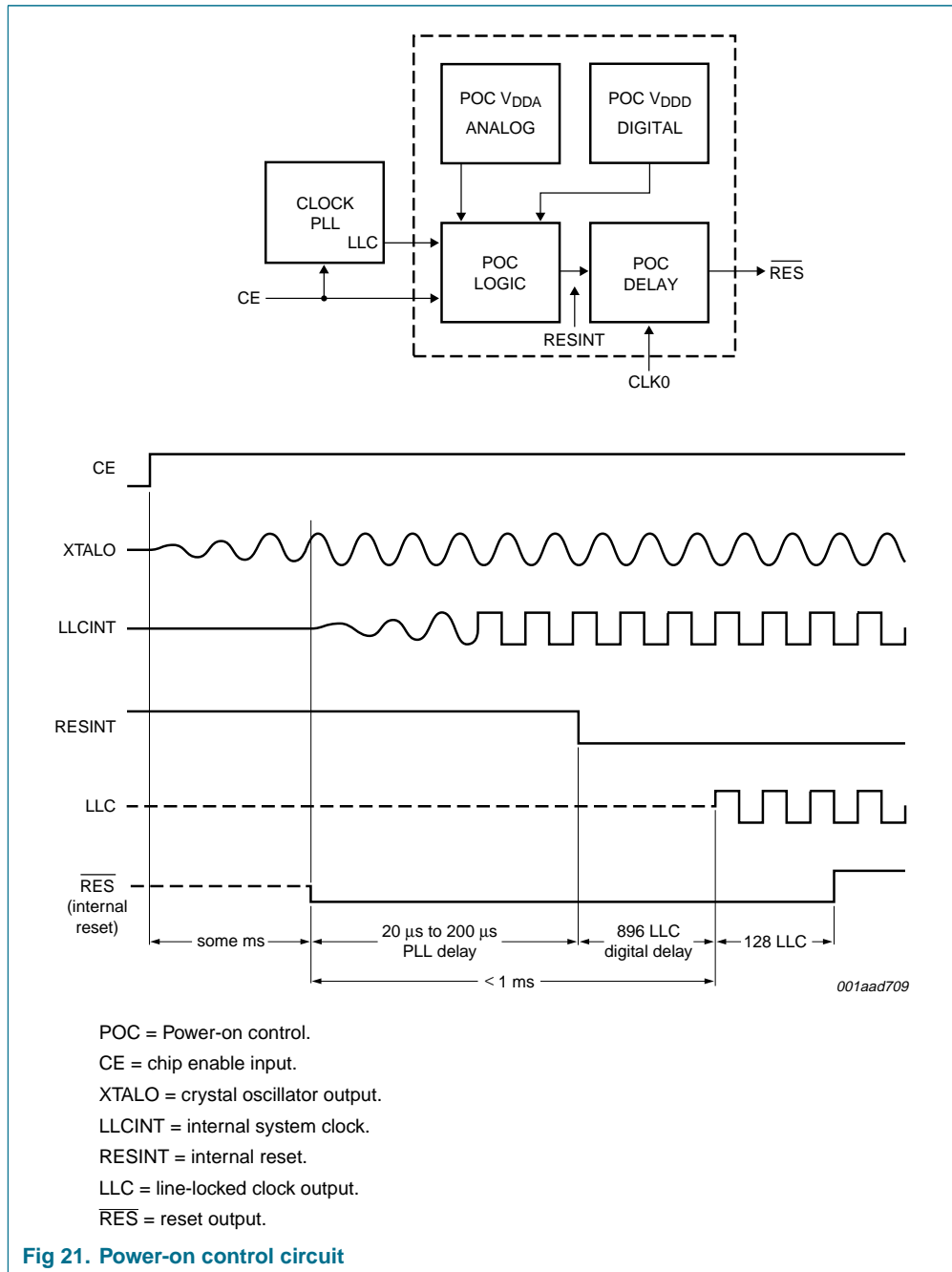

## 8.2 Decoder output formatter

The output interface block of the decoder part contains the ITU 656 formatter for the expansion port data output XPD7 to XPD0 (for a detailed description see [Section 9.4.1](#)) and the control circuit for the signals needed for the internal paths to the scaler and data slicer part. It also controls the selection of the reference signals for the RT port (RTCO, RTS0 and RTS1) and the expansion port (XRH, XRV and XDQ).

The generation of the decoder data type control signals SET\_RAW and SET\_VBI is also done within this block. These signals are decoded from the requested data type for the scaler input and/or the data slicer, selectable by the control registers LCR2 to LCR24 (see also [Section 10](#); subaddresses 41h to 57h).

For each LCR value from 2 to 23 the data type can be programmed individually; LCR2 to LCR23 refer to line numbers. The selection in LCR24 values is valid for the rest of the corresponding field. The upper nibble contains the value for field 1 (odd), the lower nibble for field 2 (even). The relationship between LCR values and line numbers can be adjusted via VOFF8 to VOFF0, located in subaddresses 5Bh (bit D4) and 5Ah (bits D7 to D0) and F0FF subaddress 5Bh (bit D7). The recommended values are VOFF[8:0] = 03h for 50 Hz sources (with F0FF = 0) and VOFF[8:0] = 06h for 60 Hz sources (with F0FF = 1), to accommodate line number conventions as used for PAL, SECAM and NTSC standards; see [Figure 22](#) and [Figure 23](#).

**Table 7: Data formats at decoder output**

Data type number	Data type	Decoder output data format
0	teletext EuroWST, CCST	raw
1	European closed caption	raw
2	Video Programming Service (VPS)	raw
3	wide screen signalling bits	raw
4	US teletext (WST)	raw
5	US closed caption (line 21)	raw
6	video component signal, VBI region	Y-C <sub>B</sub> -C <sub>R</sub> 4 : 2 : 2
7	CVBS data	raw
8	teletext	raw
9	VITC/EBU time codes (Europe)	raw
10	VITC/SMPTE time codes (USA)	raw
11	reserved	raw
12	US NABTS	raw
13	MOJI (Japanese)	raw
14	Japanese format switch (L20/22)	raw
15	video component signal, active video region	Y-C <sub>B</sub> -C <sub>R</sub> 4 : 2 : 2

LINE NUMBER (1st FIELD)	521	522	523	524	525	1	2	3	4	5	6	7	8	9
	active video					equalization pulses			serration pulses			equalization pulses		
LINE NUMBER (2nd FIELD)	259	260	261	262	263	264	265	266	267	268	269	270	271	272
	active video					equalization pulses			serration pulses			equalization pulses		
LCR	24					2	3	4	5	6	7	8	9	

LINE NUMBER (1st FIELD)	10	11	12	13	14	15	16	17	18	19	20	21	22	23	24	25
	nominal VBI lines F1												active video			
LINE NUMBER (2nd FIELD)	273	274	275	276	277	278	279	280	281	282	283	284	285	286	287	288
	nominal VBI lines F2												active video			
LCR	10	11	12	13	14	15	16	17	18	19	20	21	22	23	24	

001aad425

Vertical line offset, VOFF[8:0] = 06h (subaddresses 5Bh[4] and 5Ah[7:0]); horizontal pixel offset, HOFF[10:0] = 347h (subaddresses 5Bh[2:0] and 59h[7:0]); FOFF = 1 (subaddress 5Bh[7])

Fig 22. Relationship of LCR to line numbers in 525 lines/60 Hz systems

LINE NUMBER (1st FIELD)	621	622	623	624	625	1	2	3	4	5
	active video			equalization pulses		serration pulses			equalization pulses	
LINE NUMBER (2nd FIELD)	309	310	311	312	313	314	315	316	317	318
	active video			equalization pulses		serration pulses			equalization pulses	
LCR	24					2	3	4	5	

LINE NUMBER (1st FIELD)	6	7	8	9	10	11	12	13	14	15	16	17	18	19	20	21	22	23	24	25
	nominal VBI lines F1																			active video
LINE NUMBER (2nd FIELD)	319	320	321	322	323	324	325	326	327	328	329	330	331	332	333	334	335	336	337	338
	nominal VBI lines F2																			active video
LCR	6	7	8	9	10	11	12	13	14	15	16	17	18	19	20	21	22	23	24	

001aad426

Vertical line offset, VOFF[8:0] = 03h (subaddresses 5Bh[4] and 5Ah[7:0]); horizontal pixel offset, HOFF[10:0] = 347h (subaddresses 5Bh[2:0] and 59h[7:0]); FOFF = 0 (subaddress 5Bh[7])

Fig 23. Relationship of LCR to line numbers in 625 lines/50 Hz systems

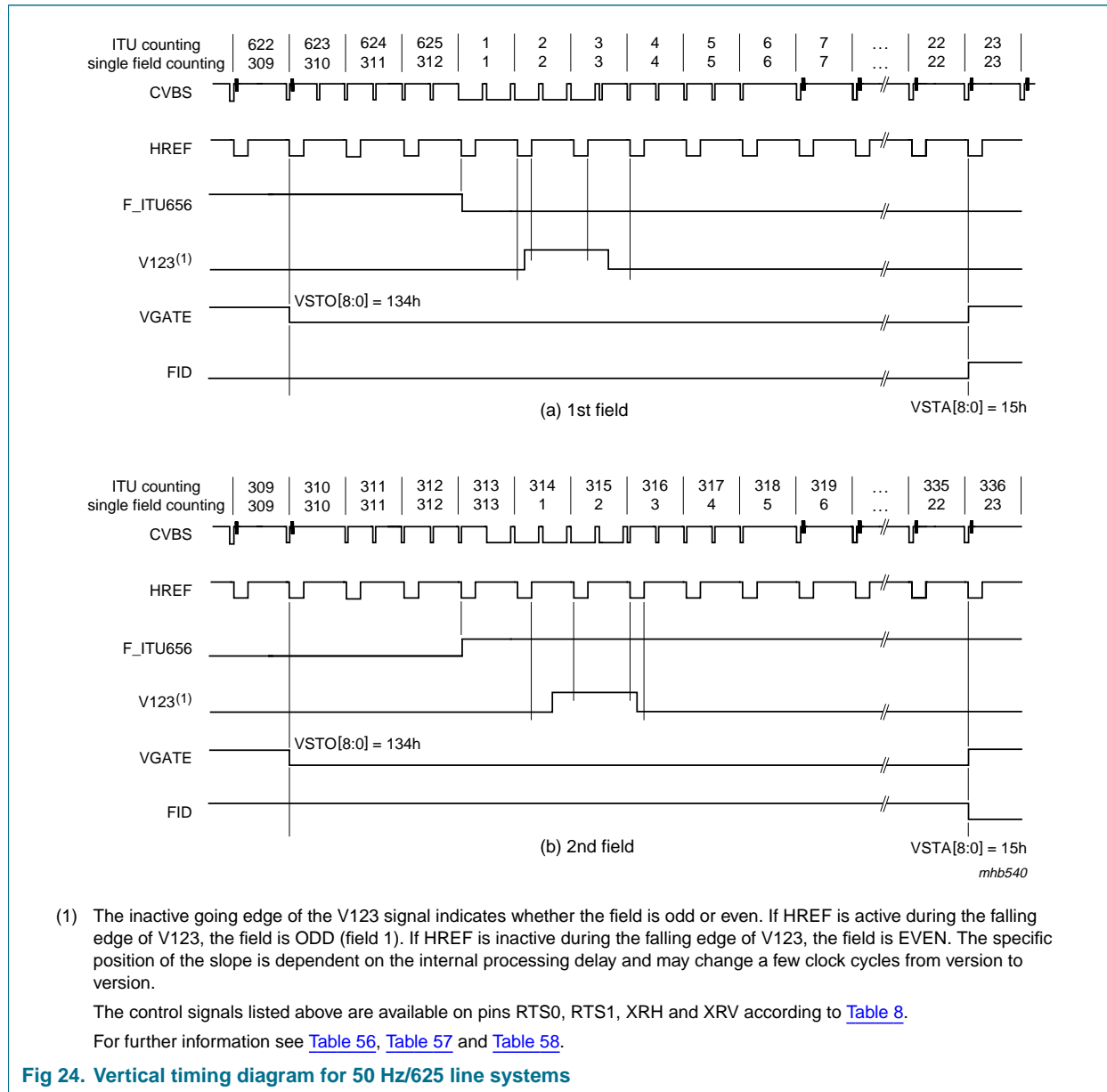
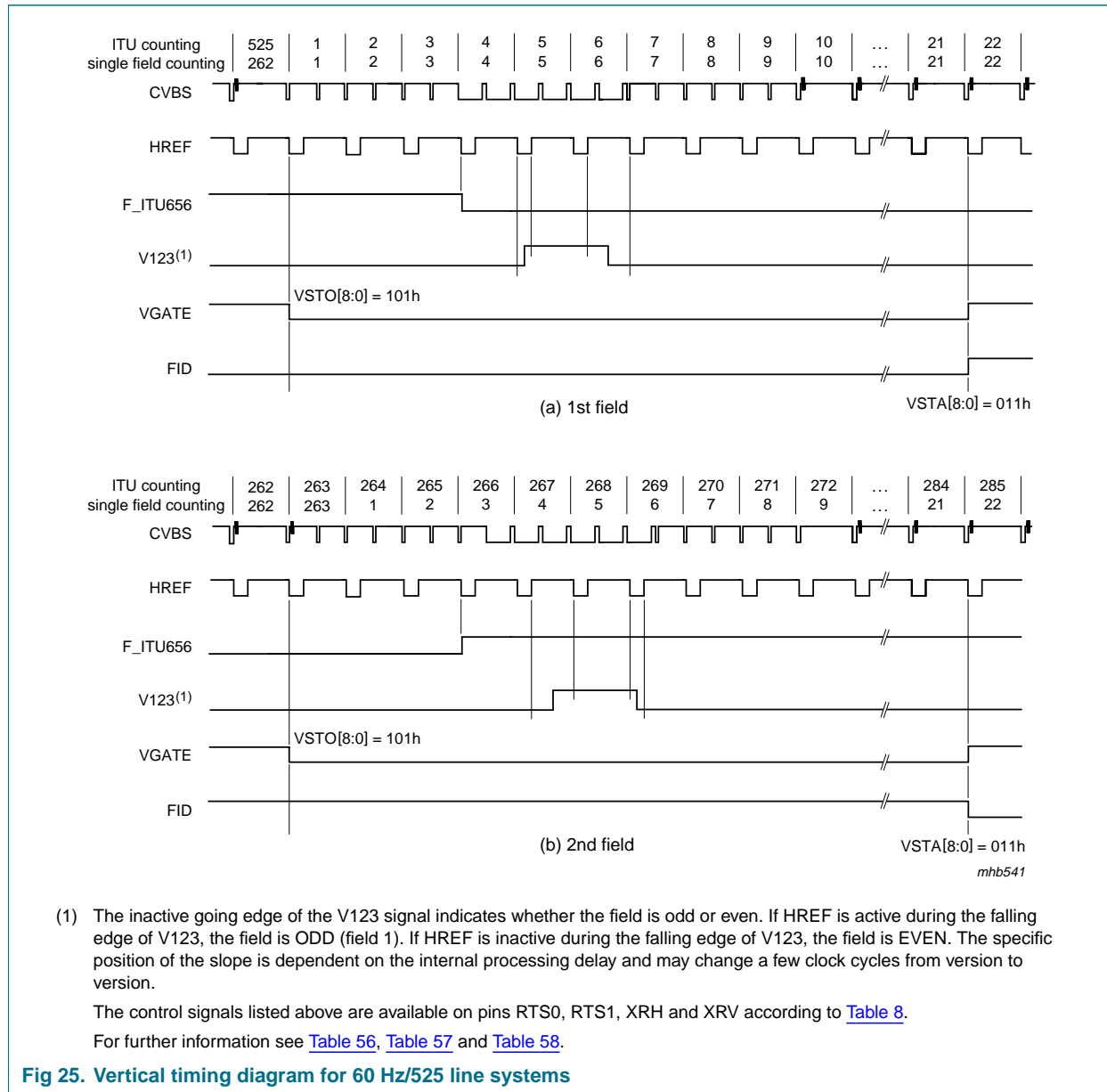
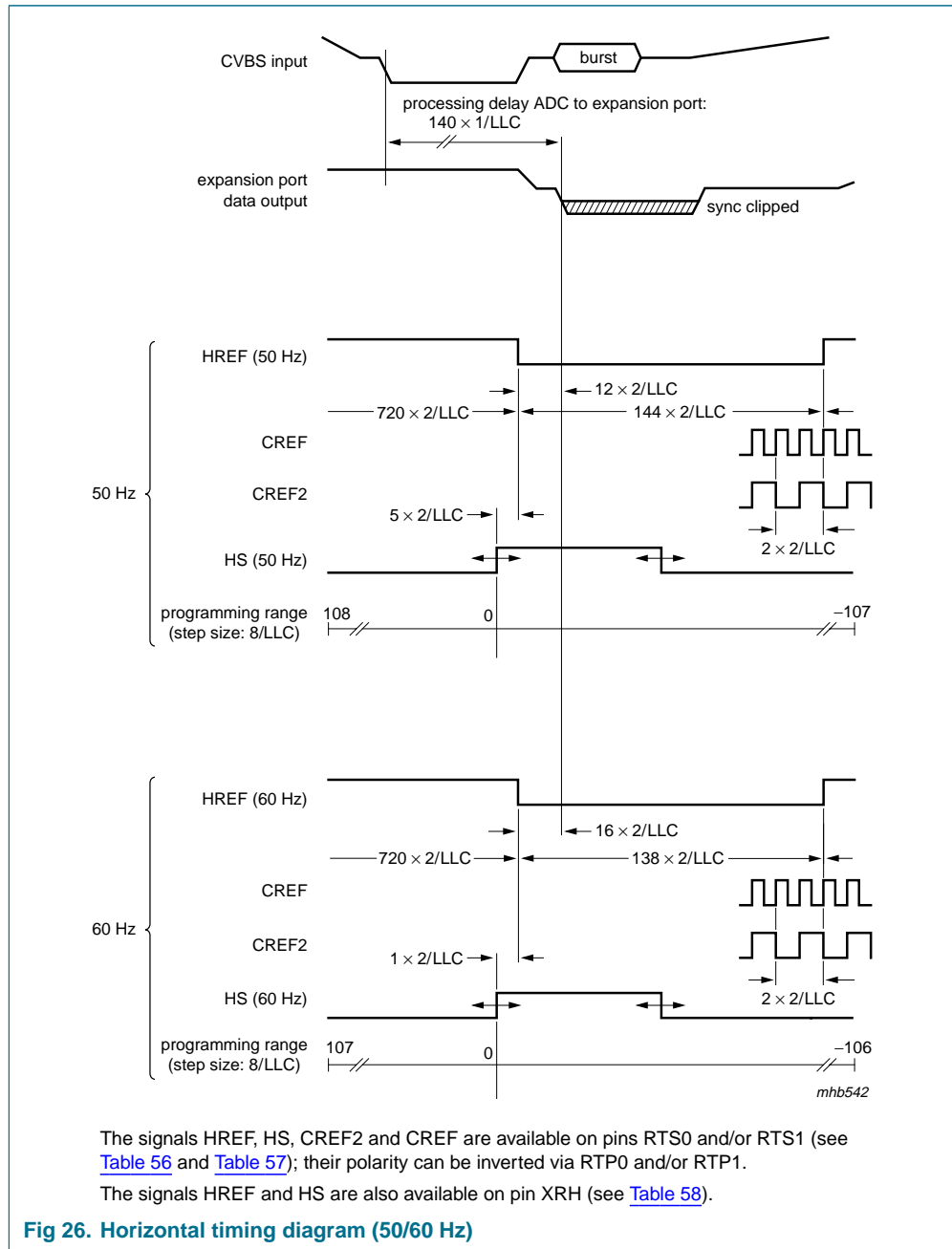

Table 8: Control signals

Name	RTS0	RTS1	XRH	XRV
HREF	X	X	X	-
F_ITU656	-	-	-	X
V123	X	X	-	X
VGATE	X	X	-	-
FID	X	X	-	-





### 8.3 Scaler

The High Performance video Scaler (HPS) is based on the system as implemented in previous products (e.g. SAA7140), but with some aspects enhanced. Vertical upsampling is supported and the processing pipeline buffer capacity is enhanced, to allow more flexible video stream timing at the image port, discontinuous transfers, and handshake. The internal data flow from block to block is discontinuous dynamically, due to the scaling process.

The flow is controlled by internal data valid and data request flags (internal handshake signalling) between the sub-blocks; therefore the entire scaler acts as a pipeline buffer. Depending on the actual programmed scaling parameters the effective buffer can exceed to an entire line. The access/bandwidth requirements to the VGA frame buffer are reduced significantly.

The high performance video scaler in the SAA7114 has the following major blocks:

- Acquisition control (horizontal and vertical timer) and task handling (the region/field/frame based processing)
- Prescaler, for horizontal downscaling by an integer factor, combined with appropriate band limiting filters, especially anti-aliasing for CIF format
- Brightness, saturation, contrast control for scaled output data
- Line buffer, with asynchronous read and write, to support vertical upscaling (e.g. for videophone application, converting 240 into 288 lines, Y-C<sub>B</sub>-C<sub>R</sub> 4 : 2 : 2)
- Vertical scaling, with phase accurate Linear Phase Interpolation (LPI) for zoom and downscale, or phase accurate Accumulation Mode (ACM) for large downscaling ratios and better alias suppression
- Variable Phase Delay (VPD), operates as horizontal phase accurate interpolation for arbitrary non-integer scaling ratios, supporting conversion between square and rectangular pixel sampling
- Output formatter for scaled Y-C<sub>B</sub>-C<sub>R</sub> 4 : 2 : 2, Y-C<sub>B</sub>-C<sub>R</sub> 4 : 1 : 1 and Y only (format also used for raw data)
- FIFO, 32-bit wide, with 64 pixel capacity in Y-C<sub>B</sub>-C<sub>R</sub> formats
- Output interface, 8-bit or 16-bit (only if extended by H port) data pins wide, synchronous or asynchronous operation, with stream events on discrete pins, or coded in the data stream

The overall H and V zooming (HV\_zoom) is restricted by the input/output data rate relationships. With a safety margin of 2 % for running in and running out, the maximum

$$\text{HV\_zoom is equal to: } 0.98 \times \frac{T_{\text{input\_field}} - T_{\text{v\_blanking}}}{\text{in\_pixel} \times \text{in\_lines} \times \text{out\_cycle\_per\_pix} \times T_{\text{out\_clk}}}$$

For example:

1. Input from decoder: 50 Hz, 720 pixel, 288 lines, 16-bit data at 13.5 MHz data rate, 1 cycle per pixel; output: 8-bit data at 27 MHz, 2 cycles per pixel; the maximum

$$\text{HV\_zoom is equal to: } 0.98 \times \frac{20 \text{ ms} - 24 \times 64 \text{ } \mu\text{s}}{720 \times 288 \times 2 \times 37 \text{ ns}} = 1.18$$

2. Input from X port: 60 Hz, 720 pixel, 240 lines, 8-bit data at 27 MHz data rate (ITU 656), 2 cycles per pixel; output via I + H port: 16-bit data at 27 MHz clock, 1 cycle per pixel; the maximum HV\_zoom is equal to:

$$0.98 \times \frac{16.666 \text{ ms} - 22 \times 64 \text{ } \mu\text{s}}{720 \times 240 \times 1 \times 37 \text{ ns}} = 2.34$$

The video scaler receives its input signal from the video decoder or from the expansion port (X port). It gets 16-bit Y-C<sub>B</sub>-C<sub>R</sub> 4 : 2 : 2 input data at a continuous rate of 13.5 MHz from the decoder. Discontinuous data stream can be accepted from the expansion port (X port), normally 8-bit wide ITU 656 such as Y-C<sub>B</sub>-C<sub>R</sub> data, accompanied by a pixel qualifier on XDQ.

The input data stream is sorted into two data paths, one for luminance (or raw samples) and one for time-multiplexed chrominance C<sub>B</sub> and C<sub>R</sub> samples. An Y-C<sub>B</sub>-C<sub>R</sub> 4 : 1 : 1 input format is converted to 4 : 2 : 2 for the horizontal prescaling and vertical filter scaling operation.

The scaler operation is defined by two programming pages A and B, representing two different tasks, that can be applied field alternating or to define two regions in a field (e.g. with different scaling range, factors and signal source during odd and even fields).

Each programming page contains control:

- For signal source selection and formats
- For task handling and trigger conditions
- For input and output acquisition window definition
- For H-prescaler, V-scaler and H-phase scaling

Raw VBI data is handled as a specific input format and needs its own programming page (equals own task).

In VBI pass through operation the processing of prescaler and vertical scaling has to be set to no-processing, however, the horizontal fine scaling VPD can be activated. Upscaling (oversampling, zooming), free of frequency folding, up to a factor of 3.5 can be achieved, as required by some software data slicing algorithms.

These raw samples are transported through the image port as valid data and can be output as Y only format. The lines are framed by SAV and EAV codes.

### 8.3.1 Acquisition control and task handling (subaddresses 80h, 90h, 91h, 94h to 9Fh and C4h to CFh)

The acquisition control receives horizontal and vertical synchronization signals from the decoder section or from the X port. The acquisition window is generated via pixel and line counters at the appropriate places in the data path. From X port only qualified pixels and lines (lines with qualified pixel) are counted.

The acquisition window parameters are as follows:

- Signal source selection regarding input video stream and formats from the decoder, or from X port (programming bits SCSRC[1:0] 91h[5:4] and FSC[2:0] 91h[2:0])

**Remark:** The input of raw VBI data from the internal decoder should be controlled via the decoder output formatter and the LCR registers; see [Section 8.2](#)



- Vertical offset defined in lines of the video source, parameter YO[11:0] 99h[3:0] 98h[7:0]
- Vertical length defined in lines of the video source, parameter YS[11:0] 9Bh[3:0] 9Ah[7:0]
- Vertical length defined in number of target lines, as a result of vertical scaling, parameter YD[11:0] 9Fh[3:0] 9Eh[7:0]
- Horizontal offset defined in number of pixels of the video source, parameter XO[11:0] 95h[3:0] 94h[7:0]
- Horizontal length defined in number of pixels of the video source, parameter XS[11:0] 97h[3:0] 96h[7:0]
- Horizontal destination size, defined in target pixels after fine scaling, parameter XD[11:0] 9Dh[3:0] 9Ch[7:0]

The source start offset (XO11 to XO0 and YO11 to YO0) opens the acquisition window, and the target size (XD11 to XD0 and YD11 to YD0) closes the window, however the window is cut vertically if there are less output lines than expected. The trigger events for the pixel and line counts are the horizontal and vertical reference edges as defined in subaddress 92h. The task handling is controlled by subaddress 90h; see [Section 8.3.1.2](#).

### 8.3.1.1 Input field processing

The trigger event for the field sequence detection from external signals (X port) are defined in subaddress 92h. From the X port the state of the scalers H reference signal at the time of the V reference edge is taken as field sequence identifier FID. For example, if the falling edge of the XRV input signal is the reference and the state of XRH input is logic 0 at that time, the detected field ID is logic 0.

The bits XFDV[92h[7]] and XFDH[92h[6]] define the detection event and state of the flag from the X port. For the default setting of XFDV and XFDH at '00' the state of the H-input at the falling edge of the V-input is taken.

The scaler directly gets a corresponding field ID information from the SAA7114 decoder path.

The FID flag is used to determine whether the first or second field of a frame is going to be processed within the scaler and it is used as trigger condition for the task handling (see bits STRC[1:0] 90h[1:0]).

According to ITU 656, when FID is at logic 0 means first field of a frame. To ease the application, the polarities of the detection results on the X port signals and the internal decoder ID can be changed via XFDH.

As the V-sync from the decoder path has a half line timing (due to the interlaced video signal), but the scaler processing only knows about full lines, during 1st fields from the decoder the line count of the scaler possibly shifts by one line, compared to the 2nd field. This can be compensated for by switching the V-trigger event, as defined by XDVO, to the opposite V-sync edge or by using the vertical scalers phase offsets. The vertical timing of the decoder can be seen in [Figure 24](#) and [Figure 25](#).

As the H and V reference events inside the ITU 656 data stream (from X port) and the real-time reference signals from the decoder path are processed differently, the trigger events for the input acquisition also have to be programmed differently.

Table 9: Processing trigger and start

XDV1 92h[5]	XDV0 92h[4]	XDH 92h[2]	Description
			<b>Internal decoder:</b> The processing triggers at the falling edge of the V123 pulse [see <a href="#">Figure 24</a> (50 Hz) and <a href="#">Figure 25</a> (60 Hz)], and starts earliest with the rising edge of the decoder HREF at line number:
0	1	0	4/7 (50/60 Hz, 1st field), respectively 3/6 (50/60 Hz, 2nd field) (decoder count)
0	0	0	2/5 (50/60 Hz, 1st field), respectively 2/5 (50/60 Hz, 2nd field) (decoder count)
0	0	0	<b>External ITU 656 stream:</b> The processing starts earliest with SAV at line number 23 (50 Hz system), respectively line 20 (60 Hz system) (according to ITU 656 count)

### 8.3.1.2 Task handling

The task handler controls the switching between the two programming register sets. It is controlled by subaddresses 90h and C0h. A task is enabled via the global control bits TEA[80h[4]] and TEB[80h[5]].

The handler is then triggered by events, which can be defined for each register set.

In the event of a programming error the task handling and the complete scaler can be reset to the initial states by setting the software reset bit SWRST[88h[5]] to logic 0. Especially if the programming registers, related acquisition window and scale are reprogrammed while a task is active, a software reset **must** be performed after programming.

Contrary to the disabling/enabling of a task, which is evaluated at the end of a running task, when SWRST is at logic 0 it sets the internal state machines directly to their idle states.

The start condition for the handler is defined by bits STRC[1:0] 90h[1:0] and means: start immediately, wait for next V-sync, next FID at logic 0 or next FID at logic 1. The FID is evaluated, if the vertical and horizontal offsets are reached.

When RPTSK[90h[2]] is at logic 1 the actual running task is repeated (under the defined trigger conditions), before handing control over to the alternate task.

To support field rate reduction, the handler is also enabled to skip fields (bits FSKP[2:0] 90h[5:3]) before executing the task. A TOGGLE flag is generated (used for the correct output field processing), which changes state at the beginning of a task, every time a task is activated; examples are given in [Section 8.3.1.3](#).

#### Remarks:

- **To activate a task the start condition must be fulfilled and the acquisition window offsets must be reached.**

For example, in case of 'start immediately', and two regions are defined for one field, the offset of the lower region must be greater than (offset + length) of the upper region, if not, the actual counted H and V position at the end of the upper task is beyond the programmed offsets and the processing will 'wait for next V'.

- **Basically the trigger conditions are checked, when a task is activated.** It is important to realize, that they are not checked while a task is inactive. So you can not trigger to next logic 0 or logic 1 with overlapping offset and active video ranges between the tasks (e.g. task A STRC[1:0] = 2, YO[11:0] = 310 and task B STRC[1:0] = 3, YO[11:0] = 310 results in output field rate of  $50/3$  Hz).
- **After power-on or software reset (via SWRST[88h[5]]) task B gets priority over task A**

### 8.3.1.3 Output field processing

As a reference for the output field processing, two signals are available for the back-end hardware.

These signals are the input field ID from the scaler source and a TOGGLE flag, which shows that an active task is used an odd (1, 3, 5...) or even (2, 4, 6...) number of times. Using a single or both tasks and reducing the field or frame rate with the task handling function, the TOGGLE information can be used to reconstruct an interlaced scaled picture at a reduced frame rate. The TOGGLE flag isn't synchronized to the input field detection, as it is only dependent on the interpretation of this information by the external hardware, whether the output of the scaler is processed correctly; see [Section 8.3.3](#).

With OFIDC = 0, the scalers input field ID is available as output field ID on bit D6 of SAV and EAV, respectively on pin IGP0 (IGP1), if FID output is selected.

When OFIDC[90h[6]] = 1, the TOGGLE information is available as output field ID on bit D6 of SAV and EAV, respectively on pin IGP0 (IGP1), if FID output is selected.

Additionally the bit D7 of SAV and EAV can be defined via CONLH[90h[7]]. CONLH[90h[7]] = 0 (default) sets D7 to logic 1, a logic 1 inverts the SAV/EAV bit D7. So it is possible to mark the output of both tasks by different SAV/EAV codes. This bit can also be seen as 'task flag' on pins IGP0 (IGP1), if TASK output is selected.

Table 10: Examples for field processing

Subject	Field sequence frame/field																		
	Example 1 [1]			Example 2 [2] [3]				Example 3 [2] [4] [5]						Example 4 [2] [4] [6]					
	1/1	1/2	2/1	1/1	1/2	2/1	2/2	1/1	1/2	2/1	2/2	3/1	3/2	1/1	1/2	2/1	2/2	3/1	3/2
Processed by task	A	A	A	B	A	B	A	B	B	A	B	B	A	B	B	A	B	B	A
State of detected ITU 656 FID	0	1	0	0	1	0	1	0	1	0	1	0	1	0	1	0	1	0	1
TOGGLE flag	1	0	1	1	1	0	0	1	0	1	1	0	0	0 [7]	1	1	1 [7]	0	0
Bit D6 of SAV/EAV byte	0	1	0	0	1	0	1	1	0	1	1	0	0	0 [7]	1	1	1 [7]	0	0
Required sequence conversion at the vertical scaler [8]	UP↓	LO↓	UP↓	UP↓	LO↓	UP↓	LO↓	UP↓	LO↓	UP↓	LO↓	UP↓	LO↓	UP↓	LO↓	UP↓	LO↓	UP↓	LO↓
Output [9]	O	O	O	O	O	O	O	O	O	O	O	O	O	NO	O	O	NO	O	O

- [1] Single task every field; OFIDC = 0; subaddress 90h at 40h; TEB[80h[5]] = 0.
- [2] Tasks are used to scale to different output windows, priority on task B after SWRST.
- [3] Both tasks at 1/2 frame rate; OFIDC = 0; subaddresses 90h at 43h and C0h at 42h.
- [4] In examples 3 and 4 the association between input FID and tasks can be flipped, dependent on which time the SWRST is de-asserted.
- [5] Task B at 2/3 frame rate constructed from neighboring motion phases; task A at 1/3 frame rate of equidistant motion phases; OFIDC = 1; subaddresses 90h at 41h and C0h at 45h.
- [6] Task A and B at 1/3 frame rate of equidistant motion phases; OFIDC = 1; subaddresses 90h at 41h and C0h at 49h.
- [7] State of prior field.
- [8] It is assumed that input/output FID = 0 (= upper lines); UP = upper lines; LO = lower lines.
- [9] O = data output; NO = no output.

### 8.3.2 Horizontal scaling

The overall horizontal required scaling factor has to be split into a binary and a rational value according to the equation:

$$\text{H-scale ratio} = \frac{\text{output pixel}}{\text{input pixel}}$$

$$\text{H-scale ratio} = \frac{1}{\text{XPSC}[5:0]} \times \frac{1024}{\text{XSCY}[12:0]}$$

where the parameter of prescaler  $\text{XPSC}[5:0] = 1$  to 63 and the parameter of VPD phase interpolation  $\text{XSCY}[12:0] = 300$  to 8191 (0 to 299 are only theoretical values). For example,  $\frac{1}{3.5}$  is to split in  $\frac{1}{4} \times 1.14286$ . The binary factor is processed by the prescaler, the arbitrary non-integer ratio is achieved via the variable phase delay VPD circuitry, called horizontal fine scaling. The latter calculates horizontally interpolated new samples with a 6-bit phase accuracy, which relates to less than 1 ns jitter for regular sampling scheme. Prescaler and fine scaler create the horizontal scaler of the SAA7114.

Using the accumulation length function of the prescaler ( $\text{XACL}[5:0]$  A1h[5:0]), application and destination dependent (e.g. scale for display or for a compression machine), a compromise between visible bandwidth and alias suppression can be determined.

#### 8.3.2.1 Horizontal prescaler (subaddresses A0h to A7h and D0h to D7h)

The prescaling function consists of an FIR anti-alias filter stage and an integer prescaler, which creates an adaptive prescale dependent low-pass filter to balance sharpness and aliasing effects.

The FIR prefilter stage implements different low-pass characteristics to reduce alias for downscales in the range of 1 to  $\frac{1}{2}$ . A CIF optimized filter is built-in, which reduces artefacts for CIF output formats (to be used in combination with the prescaler set to  $\frac{1}{2}$  scale); see [Table 11](#).

The function of the prescaler is defined by:

- An integer prescaling ratio  $\text{XPSC}[5:0]$  A0h[5:0] (equals 1 to 63), which covers the integer downscale range 1 to  $\frac{1}{63}$
- An averaging sequence length  $\text{XACL}[5:0]$  A1h[5:0] (equals 0 to 63); range 1 to 64
- A DC gain renormalization  $\text{XDCG}[2:0]$  A2h[2:0]; 1 down to  $\frac{1}{128}$
- The bit  $\text{XC2\_1}[\text{A2h}[3]]$ , which defines the weighting of the incoming pixels during the averaging process:
  - $\text{XC2\_1} = 0 \Rightarrow 1 + 1 \dots + 1 + 1$
  - $\text{XC2\_1} = 1 \Rightarrow 1 + 2 \dots + 2 + 1$

The prescaler creates a prescale dependent FIR low-pass, with up to (64 + 7) filter taps. The parameter  $\text{XACL}[5:0]$  can be used to vary the low-pass characteristic for a given integer prescale of  $\frac{1}{\text{XPSC}[5:0]}$ . The user can therefore decide between signal bandwidth (sharpness impression) and alias.

Equation for  $\text{XPSC}[5:0]$  calculation is:  $\text{XPSC}[5:0] = \text{lower integer of } \frac{\text{Npix\_in}}{\text{Npix\_out}}$

Where:

- The range is 1 to 63 (**value 0 is not allowed**)
- Npix\_in = number of input pixel, and
- Npix\_out = number of desired output pixel over the complete horizontal scaler

**The use of the prescaler results in a XACL[5:0] and XC2\_1 dependent gain amplification.** The amplification can be calculated according to the equation:

$$\text{DC gain} = (\text{XC2\_1} + 1) \times \text{XACL}[5:0] + (1 - \text{XC2\_1})$$

It is recommended to use sequence lengths and weights, which results in a  $2^N$  DC gain amplification, as these amplitudes can be renormalized by the XDCG[2:0] controlled  $\frac{I}{2^N}$  shifter of the prescaler.

The renormalization range of XDCG[2:0] is 1,  $\frac{1}{2}$  down to  $\frac{1}{128}$ .

Other amplifications have to be normalized by using the following BCS control circuitry. In these cases the prescaler has to be set to an overall gain of  $\leq 1$ , e.g. for an accumulation sequence of '1 + 1 + 1' (XACL[5:0] = 2 and XC2\_1 = 0), XDCG[2:0] must be set to '010', this equals  $\frac{1}{4}$  and the BCS has to amplify the signal to  $\frac{4}{3}$  (SATN[7:0] and CONT[7:0] value = lower integer of  $\frac{4}{3} \times 64$ ).

**The use of XACL[5:0] is XPSC[5:0] dependent. XACL[5:0] must be  $< 2 \times \text{XPSC}[5:0]$ .**

XACL[5:0] can be used to find a compromise between bandwidth (sharpness) and alias effects.

**Remark:** Due to bandwidth considerations XPSC[5:0] and XACL[5:0] can be chosen differently to the previously mentioned equations or [Table 12](#), as the H-phase scaling is able to scale in the range from zooming up by factor 3 to downscaling by a factor of  $\frac{1024}{8191}$ .

[Figure 29](#) and [Figure 30](#) show some resulting frequency characteristics of the prescaler.

[Table 12](#) shows the recommended prescaler programming. Other programming, other than given in [Table 12](#), may result in better alias suppression, but the resulting DC gain amplification needs to be compensated by the BCS control, according to the equation:

$$\text{CONT}[7:0] = \text{SATN}[7:0] = \text{lower integer of } \frac{2^{\text{XDCG}[2:0]}}{\text{DC gain} \times 64}$$

Where:

- $2^{\text{XDCG}[2:0]} \geq \text{DC gain}$
- $\text{DC gain} = (\text{XC2\_1} + 1) \times \text{XACL}[5:0] + (1 - \text{XC2\_1})$

For example, if XACL[5:0] = 5, XC2\_1 = 1, then the DC gain = 10 and the required XDCG[2:0] = 4.

The horizontal source acquisition timing and the prescaling ratio is identical for both the luminance path and chrominance path, but the FIR filter settings can be defined differently in the two channels.

Fade-in and fade-out of the filters is achieved by copying an original source sample each as first and last pixel after prescaling.

Figure 27 and Figure 28 show the frequency characteristics of the selectable FIR filters.

Table 11: FIR prefilter functions

PFUV[1:0] A2h[7:6] and PFY[1:0] A2h[5:4]	Luminance filter coefficients	Chrominance coefficients
00	bypassed	bypassed
01	1 2 1	1 2 1
10	-1 1 1.75 4.5 1.75 1 -1	3 8 10 8 3
11	1 2 2 2 1	1 2 2 2 1

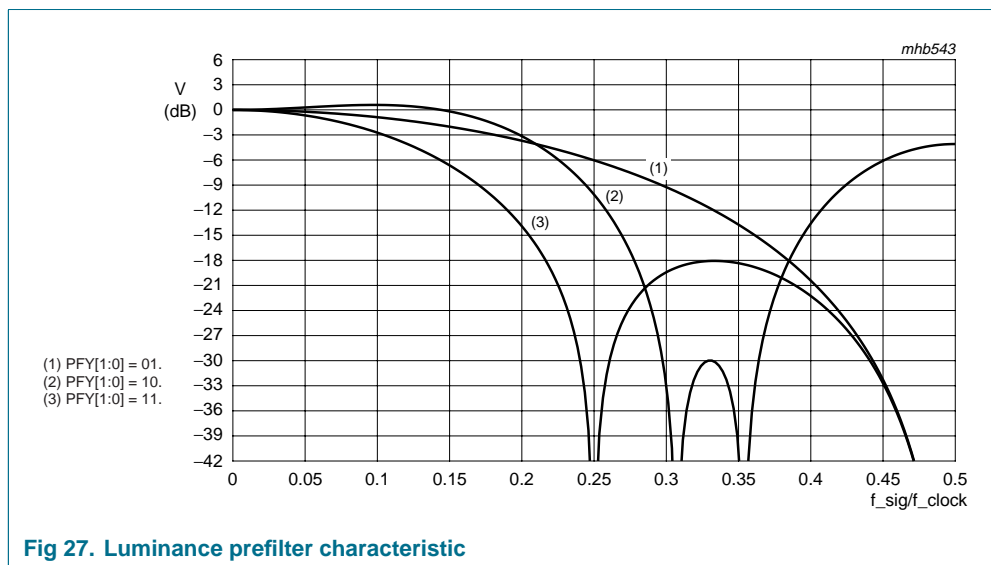

Fig 27. Luminance prefilter characteristic

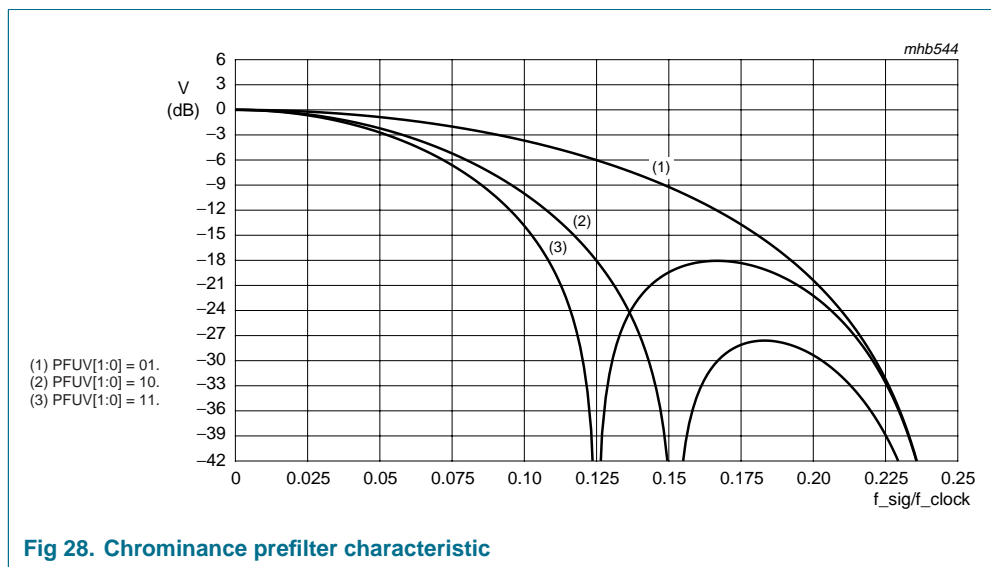

Fig 28. Chrominance prefilter characteristic

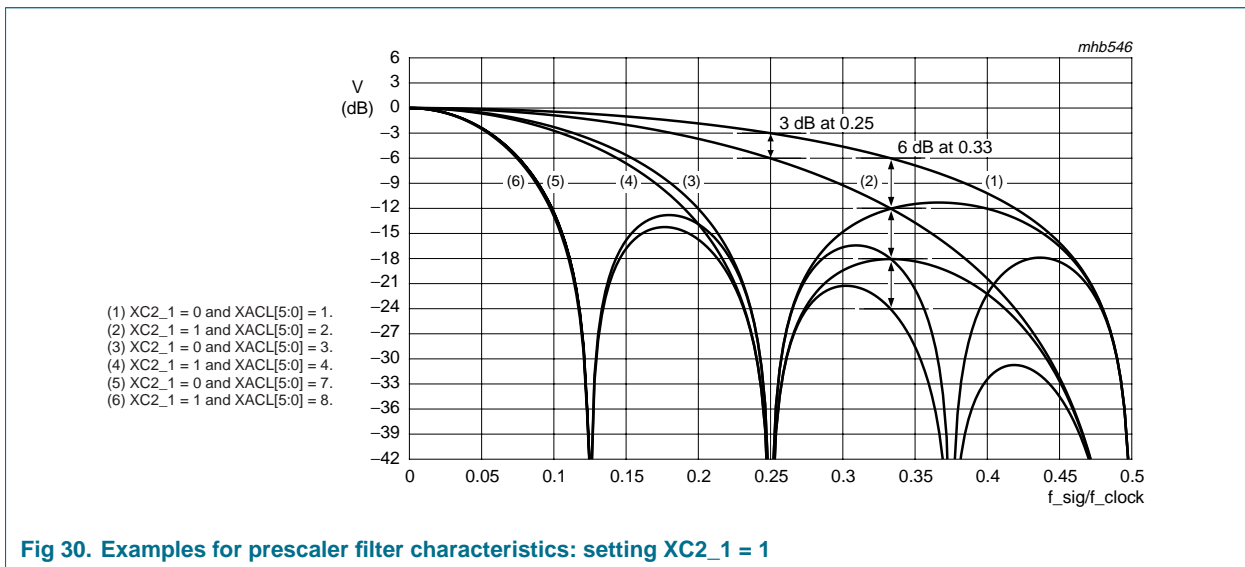
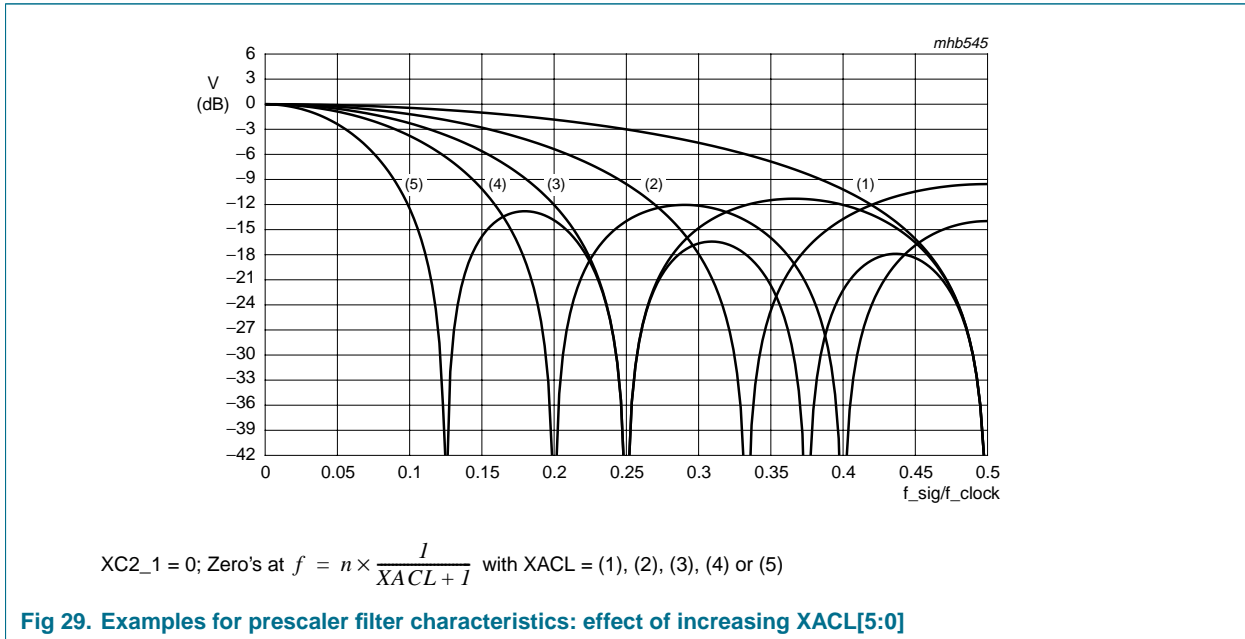



Table 12: XACL[5:0] example of usage

Prescale ratio	XPSC [5:0]	Recommended values						FIR prefilter PFY[1:0]/ PFUV[1:0]
		For lower bandwidth requirements			For higher bandwidth requirements			
		XACL[5:0]	XC2_1	XDCG[2:0]	XACL[5:0]	XC2_1	XDCG[2:0]	
1	1	0	0	0	0	0	0	0 to 2
$\frac{1}{2}$	2	2	1	2	1	0	1	0 to 2
		$(1\ 2\ 1) \times \frac{1}{4}$ [1]			$(1\ 1) \times \frac{1}{2}$ [1]			
$\frac{1}{3}$	3	4	1	3	3	0	2	2
		$(1\ 2\ 2\ 2\ 1) \times \frac{1}{8}$ [1]			$(1\ 1\ 1\ 1) \times \frac{1}{4}$ [1]			
$\frac{1}{4}$	4	7	0	3	4	1	3	2
		$(1\ 1\ 1\ 1\ 1\ 1\ 1\ 1) \times \frac{1}{8}$ [1]			$(1\ 2\ 2\ 2\ 1) \times \frac{1}{8}$ [1]			
$\frac{1}{5}$	5	8	1	4	7	0	3	2
		$(1\ 2\ 2\ 2\ 2\ 2\ 2\ 2\ 1) \times \frac{1}{16}$ [1]			$(1\ 1\ 1\ 1\ 1\ 1\ 1\ 1) \times \frac{1}{8}$ [1]			
$\frac{1}{6}$	6	8	1	4	7	0	3	3
		$(1\ 2\ 2\ 2\ 2\ 2\ 2\ 2\ 1) \times \frac{1}{16}$ [1]			$(1\ 1\ 1\ 1\ 1\ 1\ 1\ 1) \times \frac{1}{8}$ [1]			
$\frac{1}{7}$	7	8	1	4	7	0	3	3
		$(1\ 2\ 2\ 2\ 2\ 2\ 2\ 2\ 1) \times \frac{1}{16}$ [1]			$(1\ 1\ 1\ 1\ 1\ 1\ 1\ 1) \times \frac{1}{8}$ [1]			
$\frac{1}{8}$	8	15	0	4	8	1	4	3
		$(1\ 1\ 1\ 1\ 1\ 1\ 1\ 1\ 1\ 1\ 1\ 1\ 1\ 1\ 1\ 1) \times \frac{1}{16}$ [1]			$(1\ 2\ 2\ 2\ 2\ 2\ 2\ 2\ 1) \times \frac{1}{16}$ [1]			
$\frac{1}{9}$	9	15	0	4	8	1	4	3
		$(1\ 1\ 1\ 1\ 1\ 1\ 1\ 1\ 1\ 1\ 1\ 1\ 1\ 1\ 1\ 1) \times \frac{1}{16}$ [1]			$(1\ 2\ 2\ 2\ 2\ 2\ 2\ 2\ 1) \times \frac{1}{16}$ [1]			
$\frac{1}{10}$	10	16	1	5	8	1	4	3
		$(1\ 2\ 2\ 2\ 2\ 2\ 2\ 2\ 2\ 2\ 2\ 2\ 2\ 2\ 2\ 2\ 1) \times \frac{1}{32}$ [1]			$(1\ 2\ 2\ 2\ 2\ 2\ 2\ 2\ 1) \times \frac{1}{16}$ [1]			
$\frac{1}{13}$	13	16	1	5	16	1	5	3
$\frac{1}{15}$	15	31	0	5	16	1	5	3
$\frac{1}{16}$	16	32	1	6	16	1	5	3
$\frac{1}{19}$	19	32	1	6	32	1	6	3
$\frac{1}{31}$	31	32	1	6	32	1	6	3
$\frac{1}{32}$	32	63	1	7	32	1	6	3
$\frac{1}{35}$	35	63	1	7	63	1	7	3

[1] Resulting FIR function.

### 8.3.2.2 Horizontal fine scaling (variable phase delay filter; subaddresses A8h to AFh and D8h to DFh)

The horizontal fine scaling (VPD) should operate at scaling ratios between  $\frac{1}{2}$  and 2 (0.8 and 1.6), but can also be used for direct scaling in the range from  $\frac{1}{7.999}$  to (theoretical) zoom 3.5 (restriction due to the internal data path architecture), without prescaler.

In combination with the prescaler a compromise between sharpness impression and alias can be found. This is signal source and application dependent.

For the luminance channel a filter structure with 10 taps is implemented, and for the chrominance a filter with 4 taps.

Luminance and chrominance scale increments (XSCY[12:0] A9h[4:0] A8h[7:0] and XSCC[12:0] ADh[4:0] ACh[7:0]) are defined independently, but must be set in a 2 : 1 relationship in the actual data path implementation. The phase offsets XPHY[7:0] AAh[7:0] and XPHC[7:0] AEh[7:0] can be used to shift the sample phases slightly. XPHY[7:0] and XPHC[7:0] covers the phase offset range  $7.999T$  to  $\frac{1}{32}T$ . The phase offsets should also be programmed in a 2 : 1 ratio.

The underlying phase controlling DTO has a 13-bit resolution.

According to the equations:

$$XSCY[12:0] = 1024 \times \frac{N_{\text{pix\_in}}}{X_{\text{PSC}}[5:0]} \times \frac{1}{N_{\text{pix\_out}}} \quad \text{and} \quad XSCC[12:0] = \frac{XSCY[12:0]}{2}$$

the VPD covers the scale range from 0.125 to zoom 3.5. VPD acts equivalent to a polyphase filter with 64 possible phases. In combination with the prescaler, it is possible to get very accurate samples from a highly anti-aliased integer downsampled input picture.

### 8.3.3 Vertical scaling

The vertical scaler of the SAA7114 consists of a line FIFO buffer for line repetition and the vertical scaler block, which implements the vertical scaling on the input data stream in 2 different operational modes from theoretical zoom by 64 down to icon size  $\frac{1}{64}$ . The vertical scaler is located between the BCS and horizontal fine scaler, so that the BCS can be used to compensate the DC gain amplification of the ACM mode (see [Section 8.3.3.2](#)) as the internal RAMs are only 8-bit wide.

#### 8.3.3.1 Line FIFO buffer (subaddresses 91h, B4h and C1h, E4h)

The line FIFO buffer is a dual ported RAM structure for 768 pixels, with asynchronous write and read access. The line buffer can be used for various functions, but not all functions may be available simultaneously.

The line buffer can buffer a complete unscaled active video line or more than one shorter lines (only for non-mirror mode), for selective repetition for vertical zoom-up.

For zooming up 240 lines to 288 lines e.g., every fourth line is requested (read) twice from the vertical scaling circuitry for calculation.

For conversion of a 4 : 2 : 0 or 4 : 1 : 0 input sampling scheme (MPEG, video phone, Indeo YUV-9) to ITU like sampling scheme 4 : 2 : 2, the chrominance line buffer is read twice or four times, before being refilled again by the source. It has to be preserved by means of the input acquisition window definition, so that the processing starts with a line containing luminance and chrominance information for 4 : 2 : 0 and 4 : 1 : 0 input. The bits FSC[2:1] 91h[2:1] define the distance between the Y/C lines. In the event of 4 : 2 : 2 and 4 : 1 : 1 FSC2 and FSC1 have to be set to '00'.

The line buffer can also be used for mirroring, i.e. for flipping the image left to right, for the vanity picture in video phone applications (bit YMIR[B4h[4]]). In mirror mode only one active prescaled line can be held in the FIFO at a time.

The line buffer can be utilized as an excessive pipeline buffer for discontinuous and variable rate transfer conditions at the expansion port or image port.

### 8.3.3.2 Vertical scaler (subaddresses B0h to BFh and E0h to EFh)

Vertical scaling of any ratio from 64 (theoretical zoom) to  $\frac{1}{63}$  (icon) can be applied.

The vertical scaling block consists of another line delay, and the vertical filter structure, that can operate in two different modes; Linear Phase Interpolation (LPI) and accumulation (ACM) mode. These are controlled by YMODE[B4h[0]]:

- **LPI mode:** In LPI mode (YMODE = 0) two neighboring lines of the source video stream are added together, but weighted by factors corresponding to the vertical position (phase) of the target output line relative to the source lines. This linear interpolation has a 6-bit phase resolution, which equals 64 intra line phases. It interpolates between two consecutive input lines only. LPI mode should be applied for scaling ratios around 1 (down to  $\frac{1}{2}$ ), **it must be applied for vertical zooming.**
- **ACM mode:** The vertical Accumulation (ACM) mode (YMODE = 1) represents a vertical averaging window over multiple lines, sliding over the field. This mode also generates phase correct output lines. The averaging window length corresponds to the scaling ratio, resulting in an adaptive vertical low-pass effect, to greatly reduce aliasing artefacts. ACM can be applied for downscales only from ratio 1 down to  $\frac{1}{64}$ . ACM results in a scale dependent **DC gain amplification**, which has to be precorrected by the BCS control of the scaler part.

The phase and scale controlling DTO calculates in 16-bit resolution, controlled by parameters YSCY[15:0] B1h[7:0] B0h[7:0] and YSCC[15:0] B3h[7:0] B2h[7:0], continuously over the entire field. A start offset can be applied to the phase processing by means of the parameters YPY3[7:0] to YPY0[7:0] in BFh[7:0] to BCh[7:0] and YPC3[7:0] to YPC0[7:0] in BBh[7:0] to B8h[7:0]. The start phase covers the range of  $\frac{255}{32}$  to  $\frac{1}{32}$  lines offset.

By programming appropriate, opposite, vertical start phase values (subaddresses B8h to BFh and E8h to EFh) depending on odd or even field ID of the source video stream and A or B page cycle, frame ID conversion and field rate conversion are supported (i.e. de-interlacing, re-interlacing).

[Figure 31](#) and [Figure 32](#) and [Table 13](#) and [Table 14](#) describe the use of the offsets.

**Remark: The vertical start phase, as well as scaling ratio are defined independently for the luminance and chrominance channel, but must be set to the same values in the actual implementation for accurate 4 : 2 : 2 output processing.**

The vertical processing communicates on its input side with the line FIFO buffer. The scale related equations are:

- Scaling increment calculation for ACM and LPI mode, downscale and zoom:

$$\text{YSCY}[15:0] \text{ and } \text{YSCC}[15:0] = \text{lower integer of } \left( 1024 \times \frac{\text{Nline\_in}}{\text{Nline\_out}} \right)$$

- BCS value to compensate DC gain in ACM mode (contrast and saturation have to be set): CONT[7:0] A5h[7:0] respectively SATN[7:0] A6h[7:0]

$$= \text{lower integer of } \left( \frac{\text{Nline\_out}}{\text{Nline\_in}} \times 64 \right), \text{ or } = \text{lower integer of } \left( \frac{1024}{\text{YSCY}[15:0]} \times 64 \right)$$

8.3.3.3 Use of the vertical phase offsets

As described in Section 8.3.1.3, the scaler processing may run randomly over the interlaced input sequence. Additionally the interpretation and timing between ITU 656 field ID and real-time detection by means of the state of H-sync at the falling edge of V-sync may result in different field ID interpretation.

A vertically scaled interlaced output also gets a larger vertical sampling phase error, if the interlaced input fields are processed, without regard to the actual scale at the starting point of operation (see Figure 31).

For correct interlaced processing the vertical scaler must be used with respect to the interlace properties of the input signal and, if required, for conversion of the field sequences.

Four events should be considered, they are illustrated in Figure 32.

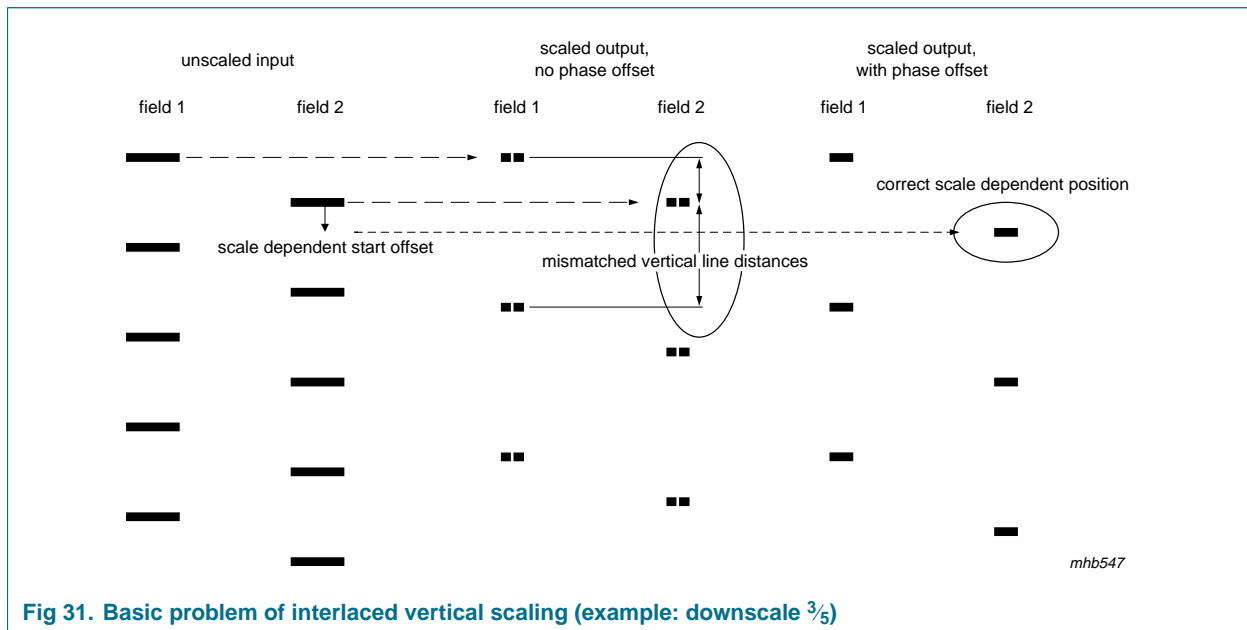
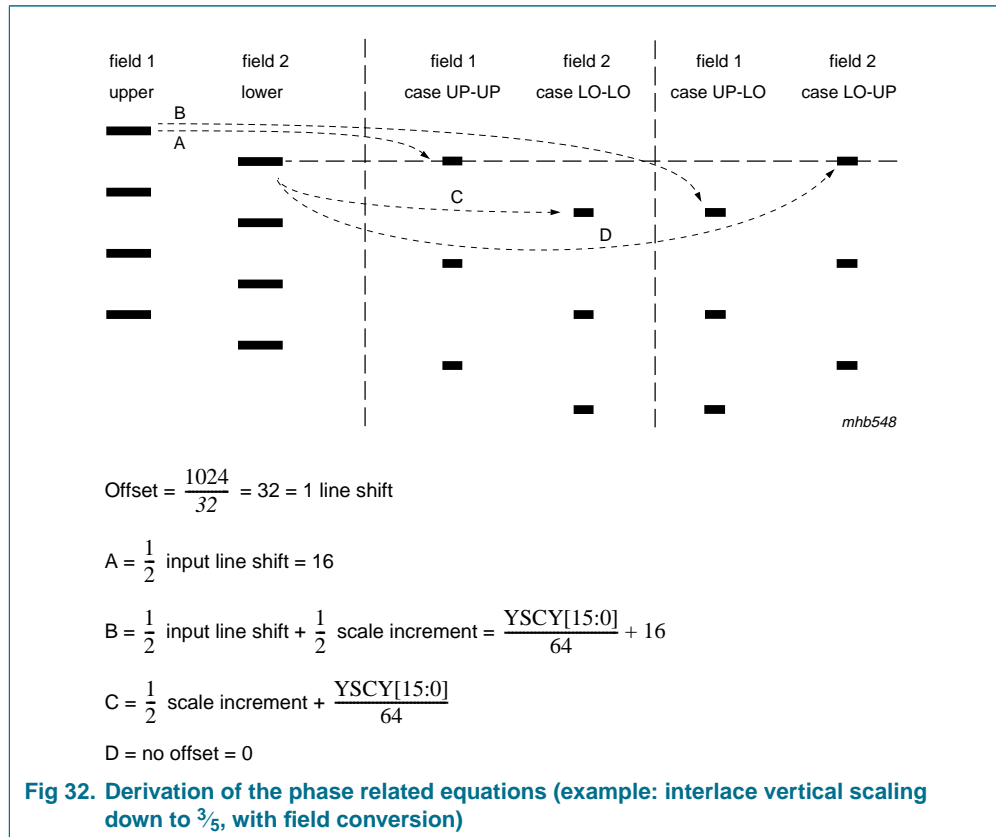

Fig 31. Basic problem of interlaced vertical scaling (example: downscale 3/5)



In [Table 13](#) and [Table 14](#) PHO is a usable common phase offset.

It should be noted that the equations of [Figure 32](#) produce an interpolated output, also for the unscaled case, as the geometrical reference position for all conversions is the position of the first line of the lower field; see [Table 14](#).

If there is no need for UP-LO and LO-UP conversion and the input field ID is the reference for the back-end operation, then it is UP-LO = UP-UP and LO-UP = LO-LO and the  $\frac{1}{2}$  line phase shift (PHO + 16) that can be skipped. This case is listed in [Table 14](#).

The SAA7114 supports 4 phase offset registers per task and component (luminance and chrominance). The value of 20h represents a phase shift of one line.

The registers are assigned to the following events; e.g. subaddresses B8h to BBh:

- B8h: 00 = input field ID 0, task status bit D0 (toggle status; see [Section 8.3.1.3](#))
- B9h: 01 = input field ID 0, task status bit D1
- BAh: 10 = input field ID 1, task status bit D0
- BBh: 11 = input field ID 1, task status bit D1

Depending on the input signal (interlaced or non-interlaced) and the task processing 50 Hz or field reduced processing with one or two tasks (see examples in [Section 8.3.1.3](#)), other combinations may also be possible, but the basic equations are the same.

Table 13: Examples for vertical phase offset usage: global equations

Input field under processing	Output field interpretation	Used abbreviation	Equation for phase offset calculation (decimal values)
Upper input lines	upper output lines	UP-UP	PHO + 16
Upper input lines	lower output lines	UP-LO	$PHO + \frac{YSCY[15:0]}{64} + 16$
Lower input lines	upper output lines	LO-UP	PHO
Lower input lines	lower output lines	LO-LO	$PHO + \frac{YSCY[15:0]}{64}$

Table 14: Vertical phase offset usage; assignment of the phase offsets

Detected input field ID	Task status bit	Vertical phase offset	Case	Equation to be used
0 = upper lines	0	YPY0[7:0] and YPC0[7:0]	case 1 <a href="#">[1]</a>	UP-UP (PHO)
			case 2 <a href="#">[2]</a>	UP-UP
			case 3 <a href="#">[3]</a>	UP-LO
0 = upper lines	1	YPY1[7:0] and YPC1[7:0]	case 1	UP-UP (PHO)
			case 2	UP-LO
			case 3	UP-UP
1 = lower lines	0	YPY2[7:0] and YPC2[7:0]	case 1	$LO-LO \left( PHO + \frac{YSCY[15:0]}{64} - 16 \right)$
			case 2	LO-UP
			case 3	LO-LO
1 = lower lines	1	YPY3[7:0] and YPC3[7:0]	case 1	$LO-LO \left( PHO + \frac{YSCY[15:0]}{64} - 16 \right)$
			case 2	LO-LO
			case 3	LO-UP

[1] Case 1: OFIDC[90h[6]] = 0; scaler input field ID as output ID; back-end interprets output field ID at logic 0 as upper output lines.

[2] Case 2: OFIDC[90h[6]] = 1; task status bit as output ID; back-end interprets output field ID at logic 0 as upper output lines.

[3] Case 3: OFIDC[90h[6]] = 1; task status bit as output ID; back-end interprets output field ID at logic 1 as upper output lines.

## 8.4 VBI data decoder and capture (subaddresses 40h to 7Fh)

The SAA7114 contains a versatile VBI data decoder.

The implementation and programming model is in accordance with the VBI data slicer built into the multimedia video data acquisition circuit SAA5284.

The circuitry recovers the actual clock phase during the clock run-in period, slices the data bits with the selected data rate, and groups them into bytes. The result is buffered into a dedicated VBI data FIFO with a capacity of  $2 \times 56$  bytes ( $2 \times 14$  Dwords). The clock frequency, signal source, field frequency and accepted error count must be defined in subaddress 40h.

The supported VBI data standards are shown in [Table 15](#).

For lines 2 to 24 of a field, per VBI line, 1 of 16 standards can be selected (LCR24\_[7:0] to LCR2\_[7:0] in 57h[7:0] to 41h[7:0]:  $23 \times 2 \times 4$  bit programming bits).

The definition for line 24 is valid for the rest of the corresponding field, normally no text data (video data) should be selected there (LCR24\_[7:0] = FFh) to stop the activity of the VBI data slicer during active video.

To adjust the slicers processing to the input signal source, there are offsets in the horizontal and vertical direction available: parameters HOFF[10:0] 5Bh[2:0] 59h[7:0], VOFF[8:0] 5Bh[4] 5Ah[7:0] and FOFF[5Bh[7]].

Contrary to the scalers counting, the slicers offsets define the position of the H and V trigger events related to the processed video field. The trigger events are the falling edge of HREF and the falling edge of V123 from the decoder processing part.

The relationship of these programming values to the input signal and the recommended values are given in [Figure 22](#) and [Figure 23](#).

**Table 15: Data types supported by the data slicer block**

DT[3:0] 62h[3:0]	Standard type	Data rate (Mbit/s)	Framing Code (FC)	FC window	Hamming check
0000	teletext EuroWST, CCST	6.9375	27h	WST625	always
0001	European closed caption	0.500	001	CC625	
0010	VPS	5	9951h	VPS	
0011	wide screen signalling bits	5	1E 3C1Fh	WSS	
0100	US teletext (WST)	5.7272	27h	WST525	always
0101	US closed caption (line 21)	0.503	001	CC525	
0110	(video data selected)	5	none	disable	
0111	(raw data selected)	5	none	disable	
1000	teletext	6.9375	programmable	general text	optional
1001	VITC/EBU time codes (Europe)	1.8125	programmable	VITC625	
1010	VITC/SMPTE time codes (USA)	1.7898	programmable	VITC525	
1011	reserved				
1100	US NABTS	5.7272	programmable	NABTS	optional
1101	MOJI (Japanese)	5.7272	programmable (A7h)	Japtext	
1110	Japanese format switch (L20/22)	5	programmable	open	
1111	no sliced data transmitted (video data selected)	5	none	disable	

## 8.5 Image port output formatter (subaddresses 84h to 87h)

The output interface consists of a FIFO for video and for sliced text data, an arbitration circuit, which controls the mixed transfer of video and sliced text data over the I port and a decoding and multiplexing unit, which generates the 8-bit or 16-bit wide output data stream and the accompanied reference and supporting information.

The clock for the output interface can be derived from an internal clock, decoder, expansion port, or an externally provided clock which is appropriate for e.g. VGA and frame buffer. The clock can be up to 33 MHz. The scaler provides the following video related timing reference events (signals), which are available on pins as defined by subaddresses 84h and 85h:

- Output field ID
- Start and end of vertical active video range
- Start and end of active video line
- Data qualifier or gated clock
- Actually activated programming page (if CONLH is used)
- Threshold controlled FIFO filling flags (empty, full and filled)
- Sliced data marker

The discontinuous data stream at the scaler output is accompanied by a data valid flag (or data qualifier), or is transported via a gated clock. Clock cycles with invalid data on the I port data bus (including the HPD pins in 16-bit output mode) are marked with code 00h.

The output interface also arbitrates the transfer between scaled video data and sliced text data over the I port output.

The bits VITX1 and VITX0 (subaddress 86h) are used to control the arbitration.

As a further operation the serialization of the internal 32-bit Dwords to 8-bit or optional 16-bit output, as well as the insertion of the extended ITU 656 codes (SAV/EAV for video data, ANC or SAV/EAV codes for sliced text data) are done here.

For handshake with the VGA controller, or other memory or bus interface circuitry, programmable FIFO flags are provided; see [Section 8.5.2](#).

### 8.5.1 Scaler output formatter (subaddresses 93h and C3h)

The output formatter organizes the packing into the output FIFO. The following formats are available: Y-C<sub>B</sub>-C<sub>R</sub> 4 : 2 : 2, Y-C<sub>B</sub>-C<sub>R</sub> 4 : 1 : 1, Y-C<sub>B</sub>-C<sub>R</sub> 4 : 2 : 0, Y-C<sub>B</sub>-C<sub>R</sub> 4 : 1 : 0 and Y only (e.g. for raw samples). The formatting is controlled by FSI[2:0] 93h[2:0], FOI[1:0] 93h[4:3] and FYSK[93h[5]].

The data formats are defined on Dwords, or multiples, and are similar to the video formats as recommended for PCI multimedia applications (compares to SAA7146A), but planar formats are not supported.

FSI[2:0] defines the horizontal packing of the data, FOI[1:0] defines how many Y only lines are expected, before a Y/C line will be formatted. If FYSK is set to logic 0 preceding Y only lines will be skipped, and the output will always start with a Y/C line.

Additionally the output formatter limits the amplitude range of the video data (controlled by ILLV[85h[5]]); see [Table 18](#).



Table 16: Byte stream for different output formats

Output format	Byte sequence for 8-bit output modes													
Y-C <sub>B</sub> -C <sub>R</sub> 4 : 2 : 2	C <sub>B</sub> 0	Y0	C <sub>R</sub> 0	Y1	C <sub>B</sub> 2	Y2	C <sub>R</sub> 2	Y3	C <sub>B</sub> 4	Y4	C <sub>R</sub> 4	Y5	C <sub>B</sub> 6	Y6
Y-C <sub>B</sub> -C <sub>R</sub> 4 : 1 : 1	C <sub>B</sub> 0	Y0	C <sub>R</sub> 0	Y1	C <sub>B</sub> 4	Y2	C <sub>R</sub> 4	Y3	Y4	Y5	Y6	Y7	C <sub>B</sub> 8	Y8
Y only	Y0	Y1	Y2	Y3	Y4	Y5	Y6	Y7	Y8	Y9	Y10	Y11	Y12	Y13

Table 17: Explanation to Table 16

Name	Explanation
C <sub>B</sub> n	C <sub>B</sub> (B – Y) color difference component, pixel number n = 0, 2, 4 to 718
Yn	Y (luminance) component, pixel number n = 0, 1, 2, 3 to 719
C <sub>R</sub> n	C <sub>R</sub> (R – Y) color difference component, pixel number n = 0, 2, 4 to 718

Table 18: Limiting range on I port

Limit step ILLV[85h[5]]	Valid range		Suppressed codes (hexadecimal value)	
	Decimal value	Hexadecimal value	Lower range	Upper range
0	1 to 254	01 to FE	00	FF
1	8 to 247	08 to F7	00 to 07	F8 to FF

### 8.5.2 Video FIFO (subaddress 86h)

The video FIFO at the scaler output contains 32 Dwords. That corresponds to 64 pixels in 16-bit Y-C<sub>B</sub>-C<sub>R</sub> 4 : 2 : 2 format. But as the entire scaler can act as a pipeline buffer, the actual available buffer capacity for the image port is much higher, and can exceed beyond a video line.

The image port, and the video FIFO, can operate with the video source clock (synchronous mode) or with an externally provided clock (asynchronous and burst mode), as appropriate for the VGA controller or attached frame buffer.

The video FIFO provides 4 internal flags, reporting to what extent the FIFO is actually filled.

These are:

- The FIFO Almost Empty (FAE) flag
- The FIFO Combined Flag (FCF) or FIFO filled, which is set at almost full level and reset, with hysteresis, only after the level crosses below the almost empty mark
- The FIFO Almost Full (FAF) flag
- The FIFO Overflow (FOVL) flag

The trigger levels for FAE and FAF are programmable by FFL[1:0] 86h[3:2] (16, 24, 28, full) and FEL[1:0] 86h[1:0] (16, 8, 4, empty).

The state of this flag can be seen on pins IGP0 or IGP1. The pin mapping is defined by subaddresses 84h and 85h; see [Section 9.5](#).

### 8.5.3 Text FIFO

The data of the internal VBI data slicer is collected in the text FIFO before the transmission over the I port is requested (normally before the video window starts). It is partitioned into two FIFO sections. A complete line is filled into the FIFO before a data transfer is requested. So normally, one line of text data is ready for transfer, while the next text line is collected. Thus sliced text data is delivered as a block of qualified data, without any qualification gaps in the byte stream of the I port.

The decoded VBI data is collected in the dedicated VBI data FIFO. After the capture of a line has been completed, the FIFO can be streamed through the image port, preceded by a header, giving line number and standard.

The VBI data period can be signalled via the sliced data flag on pin IGP0 or IGP1. The decoded VBI data is lead by the ITU ancillary data header (DID[5:0] 5Dh[5:0] at value < 3Eh) or by SAV/EAV codes selectable by DID[5:0] at value 3Eh or 3Fh. Pin IGP0 or IGP1 is set if the first byte of the ANC header is valid on the I port bus. It is reset if an SAV occurs. So it may frame multiple lines of text data output, in the event that the video processing starts with a distance of several video lines to the region of text data. Valid sliced data from the text FIFO is available on the I port as long as the IGP0 or IGP1 flag is set and the data qualifier is active on pin IDQ.

The decoded VBI data is presented in two different data formats, controlled by bit RECODE.

- RECODE = 1: values 00h and FFh will be recoded to even parity values 03h and FCh
- RECODE = 0: values 00h and FFh may occur in the data stream as detected

### 8.5.4 Video and text arbitration (subaddress 86h)

Sliced text data and scaled video data are transferred over the same bus, the I port. The mixed transfer is controlled by an arbitration circuit.

If the video data is transferred without any interrupt and the video FIFO does not need to buffer any output pixel, the text data is inserted after the end of a scaled video line, normally during the blanking interval of the video.

### 8.5.5 Data stream coding and reference signal generation (subaddresses 84h, 85h and 93h)

As H and V reference signals are logic 1, active gate signals are generated, which frame the transfer of the valid output data. As an alternative to the gates, H and V trigger pulses are generated on the rising edges of the gates.

Due to the dynamic FIFO behavior of the complete scaler path, the output signal timing has no fixed timing relationship to the real-time input video stream. So fixed propagation delays, in terms of clock cycles, related to the analog input cannot be defined.

The data stream is accompanied by a data qualifier. Additionally invalid data cycles are marked with code 00h.

If ITU 656 like codes are not required, they can be suppressed in the output stream.

As a further option, it is possible to provide the scaler with an external gating signal on pin ITRDY. Thereby making it possible to hold the data output for a certain time and to get valid output data in bursts of a guaranteed length.

The sketched reference signals and events can be mapped to the I port output pins IDQ, IGPH, IGPV, IGPO and IGP1. For flexible use the polarities of all the outputs can be modified. The default polarity for the qualifier and reference signals is logic 1 (active).

[Table 19](#) shows the relevant and supported SAV and EAV coding.

**Table 19: SAV/EAV codes on I port**

Event description	SAV/EAV codes on I port [1] (hexadecimal)				Comment
	MSB [2] of SAV/EAV byte = 0		MSB [2] of SAV/EAV byte = 1		
	Field ID = 0	Field ID = 1	Field ID = 0	Field ID = 1	
Next pixel is FIRST pixel of any active line	0E	49	80	C7	HREF = active; VREF = active
Previous pixel was LAST pixel of any active line, but not the last	13	54	9D	DA	HREF = inactive; VREF = active
Next pixel is FIRST pixel of any V-blanking line	25	62	AB	EC	HREF = active; VREF = inactive
Previous pixel was LAST pixel of the last active line or of any V-blanking line	38	7F	B6	F1	HREF = inactive; VREF = inactive
No valid data, don't capture and don't increment pointer	00				IDQ pin inactive

[1] The leading byte sequence is: FFh-00h-00h.

[2] The MSB of the SAV/EAV code byte is controlled by:

- a) Scaler output data: task A  $\Rightarrow$  MSB =  $\overline{\text{CONLH}}[90h[7]]$ ; task B  $\Rightarrow$  MSB =  $\overline{\text{CONLH}}[C0h[7]]$ .
- b) VBI data slicer output data: DID[5:0] 5Dh[5:0] = 3Eh  $\Rightarrow$  MSB = 1; DID[5:0] 5Dh[5:0] = 3Fh  $\Rightarrow$  MSB = 0.

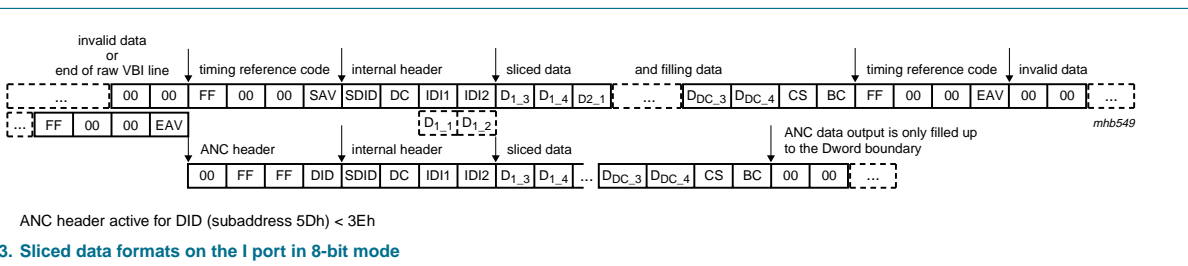

Fig 33. Sliced data formats on the I port in 8-bit mode

Table 20: Explanation to Figure 33

Name	Explanation
SAV	start of active data; see <a href="#">Table 21</a>
SDID	sliced data identification: NEP [1], EP [2], SDID5 to SDID0, freely programmable via I <sup>2</sup> C-bus subaddress 5Eh, D5 to D0, e.g. to be used as source identifier
DC	Dword count: NEP [1], EP [2], DC5 to DC0. DC describes the number of succeeding 32-bit words: For SAV/EAV mode DC is fixed to 11 Dwords (byte value 4Bh) For ANC mode it is: $DC = \frac{1}{4}(C + n)$ , where $C = 2$ (the two data identification bytes IDI1 and IDI2) and $n =$ number of decoded bytes according to the chosen text standard It should be noted that the number of valid bytes inside the stream can be seen in the BC byte.
IDI1	internal data identification 1: OP [3], FID (field 1 = 0, field 2 = 1), LineNumber8 to LineNumber3 = Dword 1 byte 1; see <a href="#">Table 21</a>
IDI2	internal data identification 2: OP [3], LineNumber2 to LineNumber0, DataType3 to DataType0 = Dword 1 byte 2; see <a href="#">Table 21</a>
D <sub>n,m</sub>	Dword number <b>n</b> , byte number <b>m</b>
D <sub>DC,4</sub>	last Dword byte 4; remark: for SAV/EAV framing DC is fixed to 0Bh, missing data bytes are filled up; the fill value is A0h
CS	the check sum byte, the check sum is accumulated from the SAV (respectively DID) byte to the D <sub>DC,4</sub> byte
BC	number of valid sliced bytes counted from the IDI1 byte
EAV	end of active data; see <a href="#">Table 21</a>

- [1] Inverted EP (bit D7); for EP see [Table note 2](#).
- [2] Even parity (bit D6) of bits D5 to D0.
- [3] Odd parity (bit D7) of bits D6 to D0.

Table 21: Bytes stream of the data slicer

Nick name	Comment	D7	D6	D5	D4	D3	D2	D1	D0
DID, SAV, EAV	subaddress 5Dh = 00h	NEP [1]	EP [2]	0	1	0	FID [3]	I1 [4]	I0 [4]
	subaddress 5Dh D5 = 1	NEP [1]	EP [2]	0	D4[5Dh]	D3[5Dh]	D2[5Dh]	D1[5Dh]	D0[5Dh]
	subaddress 5Dh D5 = 3Eh [5]	1	FID [3]	V [6]	H [7]	P3	P2	P1	P0
	subaddress 5Dh D5 = 3Fh [5]	0	FID [3]	V [6]	H [7]	P3	P2	P1	P0
SDID	programmable via subaddress 5Eh	NEP [1]	EP [2]	D5[5Eh]	D4[5Eh]	D3[5Eh]	D2[5Eh]	D1[5Eh]	D0[5Eh]
DC [8]		NEP [1]	EP [2]	DC5	DC4	DC3	DC2	DC1	DC0
IDI1		OP [9]	FID [3]	LN8 [10]	LN7 [10]	LN6 [10]	LN5 [10]	LN4 [10]	LN3 [10]
IDI2		OP [9]	LN2 [10]	LN1 [10]	LN0 [10]	DT3 [11]	DT2 [11]	DT1 [11]	DT0 [11]
CS	check sum byte	$\overline{CS6}$	CS6	CS5	CS4	CS3	CS2	CS1	CS0
BC	valid byte count	OP [9]	0	CNT5	CNT4	CNT3	CNT2	CNT1	CNT0

[1] NEP = inverted EP; for EP see [Table note 2](#).

[2] EP = even parity of bits D5 to D0.

[3] FID = 0: field 1; FID = 1: field 2.

[4] I1 = 0 and I0 = 0: before line 1; I1 = 0 and I0 = 1: lines 1 to 23; I1 = 1 and I0 = 0: after line 23; I1 = 1 and I0 = 1: line 24 to end of field.

[5] Subaddress 5Dh at 3Eh and 3Fh are used for ITU 656 like SAV/EAV header generation; recommended value.

[6] V = 0: active video; V = 1: blanking.

[7] H = 0: start of line; H = 1: end of line.

[8] DC = data count in Dwords according to the data type.

[9] OP = odd parity of bits D6 to D0.

[10] LN = line number.

[11] DT = data type according to table.

## 8.6 Audio clock generation (subaddresses 30h to 3Fh)

The SAA7114 incorporates the generation of a field-locked audio clock as an auxiliary function for video capture. An audio sample clock, that is locked to the field frequency, ensures that there is always the same predefined number of audio samples associated with a field, or a set of fields. This ensures synchronous playback of audio and video after digital recording (e.g. capture to hard disk), MPEG or other compression, or non-linear editing.

### 8.6.1 Master audio clock

The audio clock is synthesized from the same crystal frequency as the line-locked video clock is generated. The master audio clock is defined by the parameters:

- Audio master Clocks Per Field, ACPF[17:0] 32h[1:0] 31h[7:0] 30h[7:0] according to

$$\text{the equation: } \text{ACPF}[17:0] = \text{round} \left( \frac{\text{audio frequency}}{\text{field frequency}} \right)$$

- Audio master Clocks Nominal Increment, ACNI[21:0] 36h[5:0] 35h[7:0] 34h[7:0]

according to the equation:  $ACNI[21:0] = \text{round}\left(\frac{\text{audio frequency}}{\text{crystal frequency}} \times 2^{23}\right)$

See [Table 22](#) for examples.

**Remark:** For standard applications the synthesized audio clock AMCLK can be used directly as master clock and as input clock for port AMXCLK (short cut) to generate ASCLK and ALRCLK. For high-end applications it is recommended to use an external analog PLL circuit to enhance the performance of the generated audio clock.

**Table 22: Programming examples for audio master clock generation**

XTALO (MHz)	Field (Hz)	ACPF		ACNI	
		Decimal	Hex	Decimal	Hex
<b>AMCLK = 256 × 48 kHz (12.288 MHz)</b>					
32.11	50	245760	3 C000	3210190	30 FBCE
	59.94	205005	3 20CD	3210190	30 FBCE
24.576	50	-	-	-	-
	59.94	-	-	-	-
<b>AMCLK = 256 × 44.1 kHz (11.2896 MHz)</b>					
32.11	50	225792	3 7200	2949362	2D 00F2
	59.94	188348	2 DFBC	2949362	2D 00F2
24.576	50	225792	3 7200	3853517	3A CCCD
	59.94	188348	2 DFBC	3853517	3A CCCD
<b>AMCLK = 256 × 32 kHz (8.192 MHz)</b>					
32.11	50	163840	2 8000	2140127	20 A7DF
	59.94	136670	2 15DE	2140127	20 A7DF
24.576	50	163840	2 8000	2796203	2A AAAB
	59.94	136670	2 15DE	2796203	2A AAAB

### 8.6.2 Signals ASCLK and ALRCLK

Two binary divided signals ASCLK and ALRCLK are provided for slower serial digital audio signal transmission and for channel-select. The frequencies of these signals are defined by the following parameters:

- SDIV[5:0] 38h[5:0] according to the equation:  $f_{ASCLK} = \frac{f_{AMXCLK}}{(SDIV + 1) \times 2} \Rightarrow$

$$SDIV[5:0] = \frac{f_{AMXCLK}}{2f_{ASCLK}} - 1$$

- LRDIV[5:0] 39h[5:0] according to the equation:  $f_{ALRCLK} = \frac{f_{ASCLK}}{LRDIV \times 2} \Rightarrow$

$$LRDIV[5:0] = \frac{f_{ASCLK}}{2f_{ALRCLK}}$$

See [Table 23](#) for examples.

Table 23: Programming examples for ASCLK/ALRCLK clock generation

AMXCLK (MHz)	ASCLK (kHz)	SDIV		ALRCLK (kHz)	LRDIV	
		Decimal	Hex		Decimal	Hex
12.288	1536	3	03	48	16	10
	768	7	07	48	8	08
11.2896	1411.2	3	03	44.1	16	10
	2822.4	1	01	44.1	32	10
8.192	1024	3	03	32	16	10
	2048	1	01	32	32	10

### 8.6.3 Other control signals

Further control signals are available to define reference clock edges and vertical references; see [Table 24](#).

Table 24: Control signals for reference clock edges and vertical references

Signal	Description
APLL[3Ah[3]]	Audio PLL mode
	0 = PLL closed
	1 = PLL open
AMVR[3Ah[2]]	Audio Master clock Vertical Reference
	0 = internal V
	1 = external V
LRPH[3Ah[1]]	ALRCLK phase
	0 = invert ASCLK, ALRCLK edges triggered by falling edge of ASCLK
	1 = don't invert ASCLK, ALRCLK edges triggered by rising edge of ASCLK
SCPH[3Ah[0]]	ASCLK phase
	0 = invert AMXCLK, ASCLK edges triggered by falling edge of AMXCLK
	1 = don't invert AMXCLK, ASCLK edges triggered by rising edge of AMXCLK

## 9. Input/output interfaces and ports

The SAA7114 has 5 different I/O interfaces:

- Analog video input interface, for analog CVBS and/or Y and C input signals
- Audio clock port
- Digital real-time signal port (RT port)
- Digital video expansion port (X port), for unscaled digital video input and output
- Digital image port (I port) for scaled video data output and programming
- Digital host port (H port) for extension of the image port or expansion port from 8-bit to 16-bit

### 9.1 Analog terminals

The SAA7114 has 6 analog inputs AI21 to AI24, AI11 and AI12 for composite video CVBS or S-video Y/C signal pairs. Additionally, there are two differential reference inputs, which must be connected to ground via a capacitor equivalent to the decoupling capacitors at the 6 inputs. There are no peripheral components required other than these decoupling capacitors and 18  $\Omega$ /56  $\Omega$  termination resistors, one set per connected input signal; see application example in [Figure 53](#). Two anti-alias filters are integrated, and self adjusting via the clock frequency.

Clamp and gain control for the two ADCs are also integrated. An analog video output (pin AOUT) is provided for testing purposes.

**Table 25: Analog pin description**

Symbol	Pin <sup>[1]</sup>	I/O	Description	Bit
AI24 to AI21	P6, P7, P9 and P10 (10, 12, 14 and 16)	I	analog video signal inputs, e.g. 2 CVBS signals and two Y/C pairs can be connected simultaneously	MODE3 to MODE0
AI12 and AI11	P11 and P13 (18 and 20)	I	analog video signal inputs, e.g. 2 CVBS signals and two Y/C pairs can be connected simultaneously	MODE3 to MODE0
AOUT	M10 (22)	O	analog video output, for test purposes	AOSL1 and AOSL0
AI1D and AI2D	P12 and P8 (19 and 13)	I	analog reference pins for differential ADC operation	-

[1] Pin numbers for LQFP100 in parenthesis.

### 9.2 Audio clock signals

The SAA7114 also synchronizes the audio clock and sampling rate to the video frame rate, via a very slow PLL. This ensures that the multimedia capture and compression processes always gather the same predefined number of samples per video frame.

An audio master clock AMCLK and two divided clocks ASCLK and ALRCLK are generated:

- ASCLK: can be used as audio serial clock
- ALRCLK: audio left/right channel clock



The ratios are programmable; see [Section 8.6](#).

**Table 26: Audio clock pin description**

Symbol	Pin [1]	I/O	Description	Bit
AMCLK	K12 (37)	O	audio master clock output	ACPF[17:0] 32h[1:0] 31h[7:0] 30h[7:0] and ACNI[21:0] 36h[5:0] 35h[7:0] 34h[7:0]
AMXCLK	J12 (41)	I	external audio master clock input for the clock division circuit, can be directly connected to output AMCLK for standard applications	-
ASCLK	K14 (39)	O	serial audio clock output, can be synchronized to rising or falling edge of AMXCLK	SDIV[5:0] 38h[5:0] and SCPH[3Ah[0]]
ALRCLK	J13 (40)	O	audio channel (left/right) clock output, can be synchronized to rising or falling edge of ASCLK	LRDIV[5:0] 39h[5:0] and LRP[3Ah[1]]

[1] Pin numbers for LQFP100 in parenthesis.

### 9.3 Clock and real-time synchronization signals

For the generation of the line-locked video (pixel) clock LLC, and of the frame-locked audio serial bit clock, a crystal accurate frequency reference is required. An oscillator is built-in for fundamental or third harmonic crystals. The supported crystal frequencies are 32.11 MHz or 24.576 MHz (defined during reset by strapping pin ALRCLK).

Alternatively pin XTALI can be driven from an external single-ended oscillator.

The crystal oscillation can be propagated as a clock to other ICs in the system via pin XTOUT.

The Line-Locked Clock (LLC) is the double pixel clock of nominal 27 MHz. It is locked to the selected video input, generating baseband video pixels according to "ITU recommendation 601". In order to support interfacing circuits, a direct pixel clock (LLC2) is also provided.

The pins for line and field timing reference signals are RTCO, RTS1 and RTS0. Various real-time status information can be selected for the RTS pins. The signals are always available (output) and reflect the synchronization operation of the decoder part in the SAA7114. The function of the RTS1 and RTS0 pins can be defined by bits RTSE1[3:0] 12h[7:4] and RTSE0[3:0] 12h[3:0].

**Table 27: Clock and real-time synchronization signals**

Symbol	Pin [1]	I/O	Description	Bit
<b>Crystal oscillator</b>				
XTALI	P2 (7)	I	input for crystal oscillator or reference clock	-
XTALO	P3 (6)	O	output of crystal oscillator	-

Table 27: Clock and real-time synchronization signals ...continued

Symbol	Pin <sup>[1]</sup>	I/O	Description	Bit
XTOUT	P4 (4)	O	reference (crystal) clock output drive (optional)	XTOUTE[14h[3]]
<b>Real-time signals (RT port)</b>				
LLC	M14 (28)	O	line-locked clock, nominal 27 MHz, double pixel clock locked to the selected video input signal	-
LLC2	L14 (29)	O	line-locked pixel clock, nominal 13.5 MHz	-
RTCO	L13 (36)	O	real-time control output, transfers real-time status information supporting RTC level 3.1 (see document "RTC Functional Description", available on request)	-
RTS0	K13 (34)	O	real-time status information line 0, can be programmed to carry various real-time information; see <a href="#">Table 56</a>	RTSE0[3:0] 12h[3:0]
RTS1	L10 (35)	O	real-time status information line 1, can be programmed to carry various real-time information; see <a href="#">Table 57</a>	RTSE1[3:0] 12h[7:4]

[1] Pin numbers for LQFP100 in parenthesis.

## 9.4 Video expansion port (X port)

The expansion port is intended for transporting video streams image data from other digital video circuits such as MPEG encoder/decoder and video phone codec, to the image port (I port).

The expansion port consists of two groups of signals/pins:

- 8-bit data, I/O, regularly components video Y-C<sub>B</sub>-C<sub>R</sub> 4 : 2 : 2, i.e. C<sub>B</sub>-Y-C<sub>R</sub>-Y, byte serial, exceptionally raw video samples (e.g. ADC test); in input mode the data bus can be extended to 16-bit by pins HPD7 to HPD0.
- Clock, synchronization and auxiliary signals, accompanying the data stream, I/O

As output, these are direct copies of the decoder signals.

The data transfers through the expansion port represent a single D1 port, with half duplex mode. The SAV and EAV codes may be inserted optionally for data input (controlled by bit XCODE[92h[3]]). The input/output direction is switched for complete fields only.

Table 28: Signals dedicated to the expansion port

Symbol	Pin <sup>[1]</sup>	I/O	Description	Bit
XPD7 to XPD0	K2, K3, L1 to L3, M1, M2 and N1 (81, 82, 84 to 87, 89 and 90)	I/O	X port data: in output mode controlled by decoder section, data format see <a href="#">Table 29</a> ; in input mode Y-C <sub>B</sub> -C <sub>R</sub> 4 : 2 : 2 serial input data or luminance part of a 16-bit Y-C <sub>B</sub> -C <sub>R</sub> 4 : 2 : 2 input	OFTS[2:0] 13h[2:0], 91h[7:0] and C1h[7:0]
XCLK	M3 (94)	I/O	clock at expansion port: if output, then copy of LLC; as input normally a double pixel clock of up to 32 MHz or a gated clock (clock gated with a qualifier)	XCKS[92h[0]]
XDQ	M4 (95)	I/O	data valid flag of the expansion port input (qualifier): if output, then decoder (HREF and VGATE) gate; see <a href="#">Figure 26</a>	-
XRDY	N3 (96)	O	data request flag = ready to receive, to work with optional buffer in external device, to prevent internal buffer overflow; second function: input related task flag A/B	XRQT[83h[2]]
XRH	N2 (92)	I/O	horizontal reference signal for the X port: as output: HREF or HS from the decoder (see <a href="#">Figure 26</a> ); as input: a reference edge for horizontal input timing and a polarity for input field ID detection can be defined	XRHS[13h[6], XFDH[92h[6]] and XDH[92h[2]]
XRV	L5 (91)	I/O	vertical reference signal for the X port: as output: V123 or field ID from the decoder (see <a href="#">Figure 24</a> and <a href="#">Figure 25</a> ); as input: a reference edge for vertical input timing and for input field ID detection can be defined	XRVS[1:0] 13h[5:4], XFDV[92h[7]] and XDV[1:0] 92h[5:4]
XTRI	K1 (80)	I	port control: switches X port input 3-state	XPE[1:0] 83h[1:0]

[1] Pin numbers for LQFP100 in parenthesis.

#### 9.4.1 X port configured as output

If data output is enabled at the expansion port, then the data stream from the decoder is presented. The data format of the 8-bit data bus is dependent on the chosen data type, selectable by the line control registers LCR2 to LCR24; see [Table 7](#). In contrast to the image port, the sliced data format is not available on the expansion port. Instead, raw CVBS samples are always transferred if any sliced data type is selected.

Some details of data types on the expansion port are as follows:

- **Active video** (data type 15): contains component Y-C<sub>B</sub>-C<sub>R</sub> 4 : 2 : 2 signal, 720 active pixels per line. The amplitude and offsets are programmable via DBR17 to DBR10, DCON7 to DCON0, DSAT7 to DSAT0, OFFU1, OFFU0, OFFV1 and OFFV0. The nominal levels are illustrated in [Figure 18](#).
- **Test line** (data type 6): is similar to the active video format, with some constraints within the data processing:
  - Adaptive chrominance comb filter, vertical filter (chrominance comb filter for NTSC standards, PAL phase error correction) within the chrominance processing are disabled

- Adaptive luminance comb filter, peaking and chrominance trap are bypassed within the luminance processing

This data type is defined for future enhancements. It could be activated for lines containing standard test signals within the vertical blanking period. Currently the most sources do not contain test lines. The nominal levels are illustrated in [Figure 18](#).

- **Raw samples** (data types 0 to 5 and 7 to 14):  $C_B$ - $C_R$  samples are similar to data type 6, but CVBS samples are transferred instead of processed luminance samples within the Y time slots.

The amplitude and offset of the CVBS signal is programmable via RAWG7 to RAWG0 and RAWO7 to RAWO0; see [Section 10](#), [Table 63](#) and [Table 64](#). The nominal levels are illustrated in [Figure 19](#).

The relationship of LCR programming to line numbers is described in [Section 8.2](#), [Figure 22](#) and [Figure 23](#).

The data type selections by LCR are overruled by setting OFTS2 = 1 (subaddress 13h bit D2). This setting is mainly intended for device production test. The VPO-bus carries the upper or lower 8 bits of the two ADCs depending on the OFTS[1:0] 13h[1:0] settings; see [Table 58](#). The input configuration is done via MODE[3:0] 02h[3:0] settings; see [Table 40](#). If a Y/C mode is selected, the expansion port carries the multiplexed output signals of both ADCs, and in CVBS mode the output of only one ADC. No timing reference codes are generated in this mode.

**Remark:** The LSBs (bit D0) of the ADCs are also available on pin RTS0; see [Table 56](#).

The SAV/EAV timing reference codes define the start and end of valid data regions. The ITU-blanking code sequence '- 80 - 10 - 80 - 10 - ...' is transmitted during the horizontal blanking period between EAV and SAV.

The position of the F-bit is constant in accordance with ITU 656; see [Table 31](#) and [Table 32](#).

The V-bit can be generated in two different ways (see [Table 31](#) and [Table 32](#)) controlled via OFTS1 and OFTS0; see [Table 58](#).

The F and V bits change synchronously with the EAV code.

**Table 29: Data format on the expansion port**

Blanking period	Timing reference code (Hex) <sup>[1]</sup>	720 pixels Y- $C_B$ - $C_R$ 4 : 2 : 2 data <sup>[2]</sup>	Timing reference code (Hex) <sup>[1]</sup>	Blanking period
... 80 10	FF 00 00 SAV	$C_B0$ Y0 $C_R0$ Y1 $C_B2$ Y2 ... $C_R718$ Y719	FF 00 00 EAV	80 10 ...

[1] The generation of the timing reference codes can be suppressed by setting OFTS[2:0] to 010; see [Table 58](#). In this event the code sequence is replaced by the standard '- 80 - 10 -' blanking values.

[2] If raw samples or sliced data are selected by the line control registers (LCR2 to LCR24), the Y samples are replaced by CVBS samples.

Table 30: SAV/EAV format on expansion port XPD7 to XPD0

Bit	Symbol	Description
7		logic 1
6	F	field bit 1st field: F = 0 2nd field: F = 1 for vertical timing see <a href="#">Table 31</a> and <a href="#">Table 32</a>
5	V	vertical blanking bit VBI: V = 1 active video: V = 0 for vertical timing see <a href="#">Table 31</a> and <a href="#">Table 32</a>
4	H	format H = 0 in SAV format H = 1 in EAV format
3 to 0	P[3:0]	reserved; evaluation not recommended (protection bits according to ITU-R BT 656)

Table 31: 525 lines/60 Hz vertical timing

Line number	F (ITU 656)	V	
		OFTS[2:0] = 000 (ITU 656)	OFTS[2:0] = 001
1 to 3	1	1	according to selected VGATE position type via VSTA and VSTO (subaddresses 15h to 17h); see <a href="#">Table 60</a> to <a href="#">Table 62</a>
4 to 19	0	1	
20	0	0	
21	0	0	
22 to 261	0	0	
262	0	0	
263	0	0	
264 and 265	0	1	
266 to 282	1	1	
283	1	0	
284	1	0	
285 to 524	1	0	
525	1	0	

Table 32: 625 lines/50 Hz vertical timing

Line number	F (ITU 656)	V	
		OFTS[2:0] = 000 (ITU 656)	OFTS[1:0] = 10
1 to 22	0	1	according to selected VGATE position type via VSTA and VSTO (subaddresses 15h to 17h); see <a href="#">Table 60</a> to <a href="#">Table 62</a>
23	0	0	
24 to 309	0	0	
310	0	0	
311 and 312	0	1	
313 to 335	1	1	
336	1	0	
337 to 622	1	0	
623	1	0	
624 and 625	1	1	

#### 9.4.2 X port configured as input

If the data input mode is selected at the expansion port, then the scaler can select its input data stream from the on-chip video decoder, or from the expansion port (controlled by bit SCSRC[1:0] 91h[5:4]). Byte serial Y-C<sub>B</sub>-C<sub>R</sub> 4 : 2 : 2, or subsets for other sampling schemes, or raw samples from an external ADC may be input (see also bits FSC[2:0] 91h[2:0]). The input stream must be accompanied by an external clock (XCLK), qualifier XDQ and reference signals XRH and XRV. Instead of the reference signal, embedded SAV and EAV codes according to ITU 656 are also accepted. The protection bits are not evaluated.

XRH and XRV carry the horizontal and vertical synchronization signals for the digital video stream through the expansion port. The field ID of the input video stream is carried in the phase (edge) of XRV and state of XRH, or directly as FS (frame sync, odd/even signal) on the XRV pin (controlled by XFDV[92h[7]], XFDH[92h[6]] and XDV[1:0] 92h[5:4]).

The trigger events on XRH (rising/falling edge) and XRV (rising/falling/both edges) for the scalers acquisition window are defined by XDV[1:0] 92h[5:4] and XDH[92h[2]]. The signal polarity of the qualifier can also be defined (bit XDQ[92h[1]]). Alternatively to a qualifier, the input clock can be applied to a gated clock (clock gated with a data qualifier, controlled by bit XCKS[92h[0]]). In this event, all input data will be qualified.

#### 9.5 Image port (I port)

The image port transfers data from the scaler as well as from the VBI data slicer, if selected (maximum 33 MHz). The reference clock is available at the ICLK pin, as an output, or as an input (maximum 33 MHz). As output, ICLK is derived from the line-locked decoder or expansion port input clock. The data stream from the scaler output is normally discontinuous. Therefore valid data during a clock cycle is accompanied by a data qualifying (data valid) flag on pin IDQ. For pin constrained applications the IDQ pin can be programmed to function as a gated clock output (bit ICKS2[80h[2]]).

The data formats at the image port are defined in Dwords of 32 bits (4 bytes), such as the related FIFO structures. However the physical data stream at the image port is only 16-bit or 8-bit wide; in 16-bit mode data pins HPD7 to HPD0 are used for chrominance data. The four bytes of the Dwords are serialized in words or bytes.

Available formats are as follows:

- Y-C<sub>B</sub>-C<sub>R</sub> 4 : 2 : 2
- Y-C<sub>B</sub>-C<sub>R</sub> 4 : 1 : 1
- Raw samples
- Decoded VBI data

For handshake with the receiving VGA controller, or other memory or bus interface circuitry, F, H and V reference signals and programmable FIFO flags are provided. The information is provided on pins IGP0, IGP1, IGPH and IGPV. The functionality on these pins is controlled via subaddresses 84h and 85h.

VBI data is collected over an entire line in its own FIFO, and transferred as an uninterrupted block of bytes. Decoded VBI data can be signed by the VBI flag on pin IGP0 or IGP1.

As scaled video data and decoded VBI data may come from different and asynchronous sources, an arbitration scheme is needed. Normally the VBI data slicer has priority.

The image port consists of the pins and/or signals, as listed in [Table 33](#).

For pin constrained applications, or interfaces, the relevant timing and data reference signals can also get encoded into the data stream. Therefore the corresponding pins do not need to be connected. The minimum image port configuration requires 9 pins only, i.e. 8 pins for data including codes, and 1 pin for clock or gated clock. The inserted codes are defined in close relationship to the ITU-R BT.656 (D1) recommendation, where possible.

The following deviations from “ITU 656 recommendation” are implemented at the SAA7114 image port interface:

- SAV and EAV codes are only present in those lines, where data is to be transferred, i.e. active video lines, or VBI raw samples, no codes for empty lines
- There may be more or less than 720 pixels between SAV and EAV
- Data content and the number of clock cycles during horizontal and vertical blanking is undefined, and may not be constant
- Data stream may be interleaved with not-valid data codes, 00h, but SAV and EAV 4-byte codes are not interleaved with not-valid data codes
- There may be an irregular pattern of not-valid data, or IDQ, and as a result, C<sub>B</sub>-Y-C<sub>R</sub>-Y is not in a fixed phase to a regular clock divider
- VBI raw sample streams are enveloped with SAV and EAV, like normal video
- Decoded VBI data is transported as Ancillary (ANC) data, two modes:
  - Direct decoded VBI data bytes (8-bit) are directly placed in the ANC data field, 00h and FFh codes may appear in data block (violation to ITU-R BT.656)
  - Recoded VBI data bytes (8-bit) directly placed in ANC data field, 00h and FFh codes will be recoded to even parity codes 03h and FCh to suppress invalid ITU-R BT.656 codes

There are no empty cycles in the ancillary code and its data field. The data codes 00h and FFh are suppressed (changed to 01h or FEh respectively) in the active video stream, as well as in the VBI raw sample stream (VBI pass-through). Optionally, the number range can be further limited.

**Table 33: Signals dedicated to the image port**

Symbol	Pin <sup>[1]</sup>	I/O	Description	Bit
IPD7 to IPD0	E14, D14, C14, B14, E13, D13, C13 and B13 (54 to 57 and 59 to 62)	I/O	I port data	ICODE[93h[7]], ISWP[1:0] 85h[7:6] and IPE[1:0] 87h[1:0]
ICLK	H12 (45)	I/O	continuous reference clock at image port, can be input or output, as output decoder LLC or XCLK from X port	ICKS[1:0] 80h[1:0] and IPE[1:0] 87h[1:0]
IDQ	H14 (46)	O	data valid flag at image port, qualifier, with programmable polarity; secondary function: gated clock	ICKS2[80h[2]], IDQP[85h[0]] and IPE[1:0] 87h[1:0]
IGPH	G12 (53)	O	horizontal reference output signal, copy of the H gate signal of the scaler, with programmable polarity; alternative function: HRESET pulse	IDH[1:0] 84h[1:0], IRHP[85h[1]] and IPE[1:0] 87h[1:0]
IGPV	F13 (52)	O	vertical reference output signal, copy of the V gate signal of the scaler, with programmable polarity; alternative function: VRESET pulse	IDV[1:0] 84h[3:2], IRVP[85h[2]] and IPE[1:0] 87h[1:0]
IGP1	G13 (49)	O	general purpose output signal for I port	IDG12[86h[4]], IDG1[1:0] 84h[5:4], IG1P[85h[3]] and IPE[1:0] 87h[1:0]
IGP0	F14 (48)	O	general purpose output signal for I port	IDG02[86h[5]], IDG0[1:0] 84h[7:6], IG0P[85h[4]] and IPE[1:0] 87h[1:0]
ITRDY	J14 (42)	I	target ready input signals	-
ITRI	G14 (47)	I	port control, switches I port into 3-state	IPE[1:0] 87h[1:0]

[1] Pin numbers for LQFP100 in parenthesis.

## 9.6 Host port for 16-bit extension of video data I/O (H port)

The H port pins HPD can be used for extension of the data I/O paths to 16-bit.

The I port has functional priority. If I8\_16[93h[6]] is set to logic 1 the output drivers of the H port are enabled depending on the I port enable control. For I8\_16 = 0, the HPD output is disabled.



Table 34: Signals dedicated to the host port

Symbol	Pin <sup>[1]</sup>	I/O	Description	Bit
HPD7 to HPD0	A13, D12, C12, B12, A12, C11, B11 and A11 (64 to 67 and 69 to 72)	I/O	16-bit extension for digital I/O (chrominance component)	IPE[1:0] 87h[1:0], ITRI[8Fh[6]] and I8_16[93h[6]]

[1] Pin numbers for LQFP100 in parenthesis.

## 9.7 Basic input and output timing diagrams I port and X port

### 9.7.1 I port output timing

Figure 34 to Figure 40 illustrate the output timing via the I port. IGPH and IGPV are logic 1 active gate signals. If reference pulses are programmed, these pulses are generated on the rising edge of the logic 1 active gates. Valid data is accompanied by the output data qualifier on pin IDQ. In addition invalid cycles are marked with output code 00h.

The IDQ output pin may be defined to be a gated clock output signal (ICLK AND internal IDQ).

### 9.7.2 X port input timing

At the X port the input timing requirements are the same as those for the I port output. But different to those below:

- It is not necessary to mark invalid cycles with a 00h code
- No constraints on the input qualifier (can be a random pattern)
- XCLK may be a gated clock (XCLK AND external XDQ)

**Remark:** All timings illustrated in Figure 34 to Figure 40 are given for an uninterrupted output stream (no handshake with the external hardware).

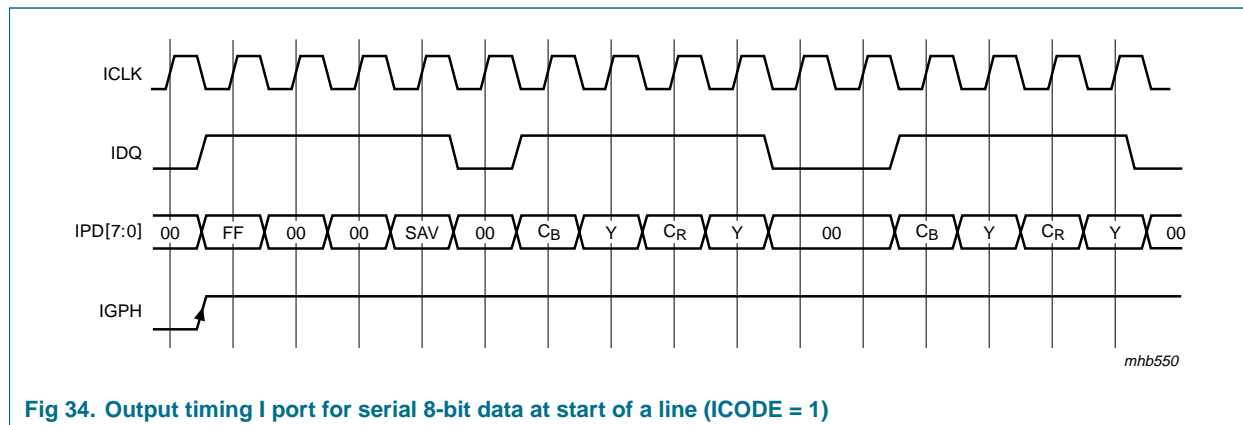

Fig 34. Output timing I port for serial 8-bit data at start of a line (ICODE = 1)

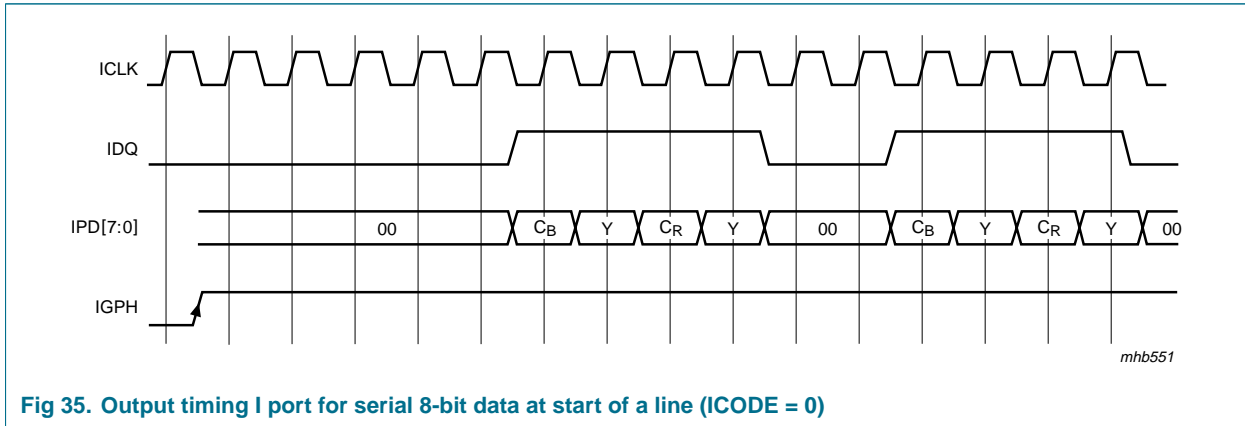

Fig 35. Output timing I port for serial 8-bit data at start of a line (ICODE = 0)

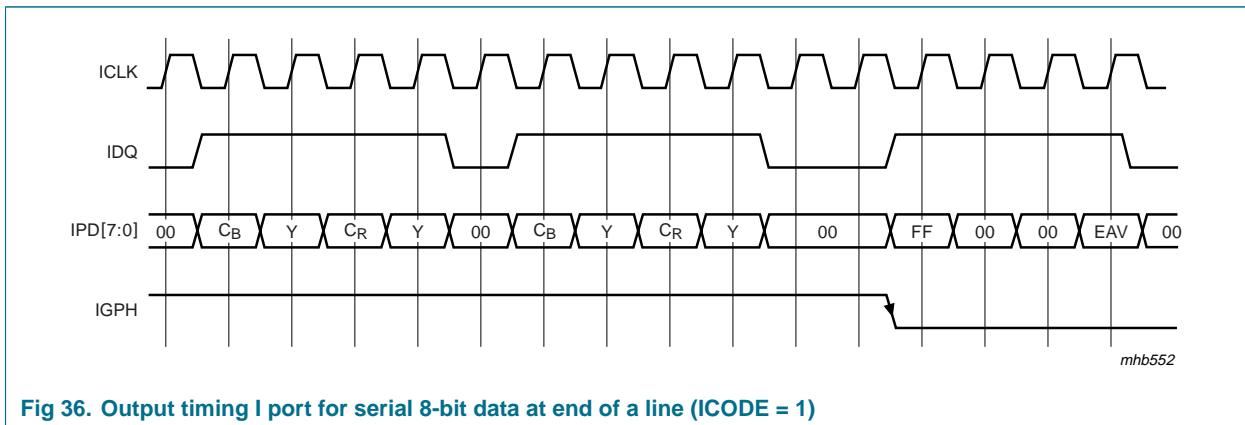

Fig 36. Output timing I port for serial 8-bit data at end of a line (ICODE = 1)

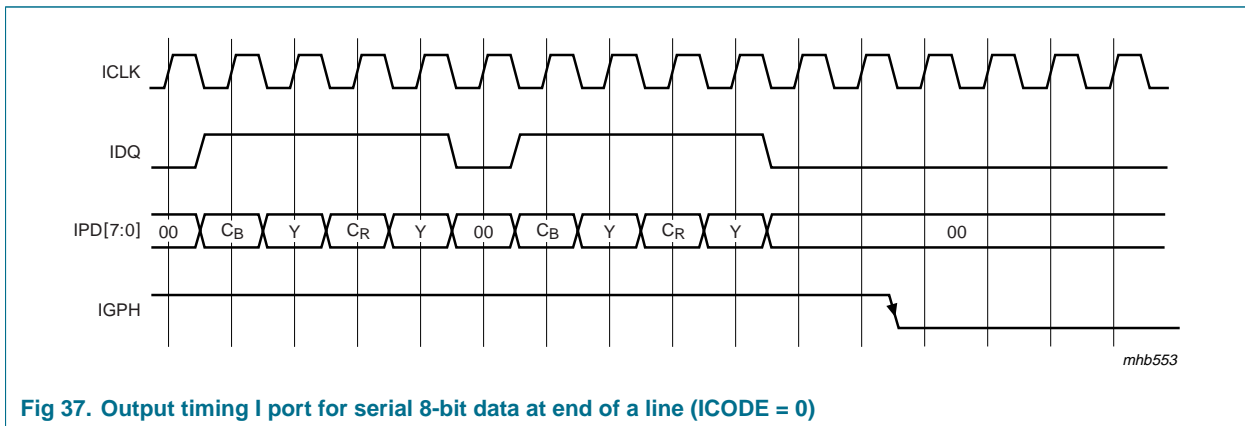
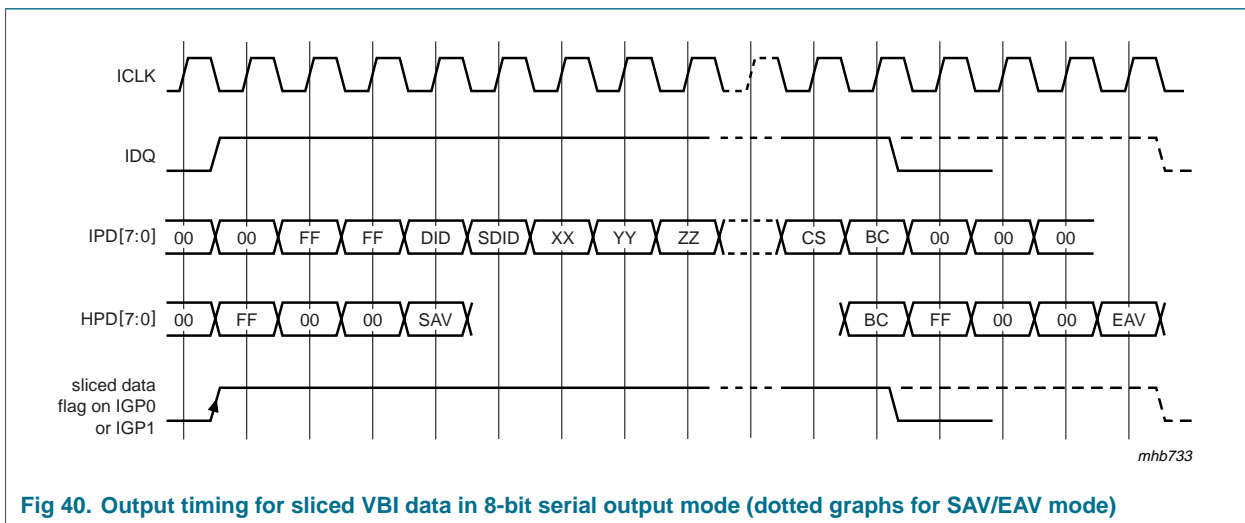
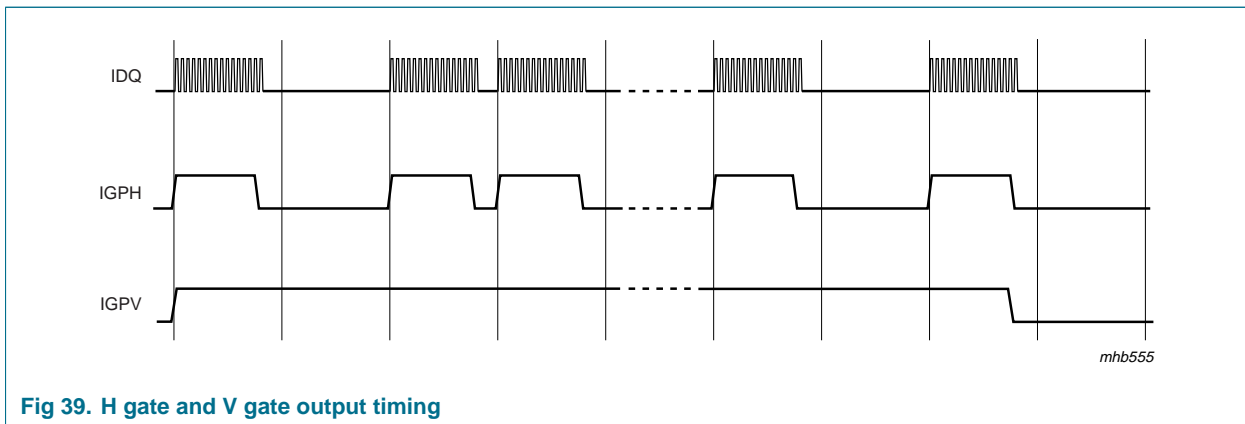
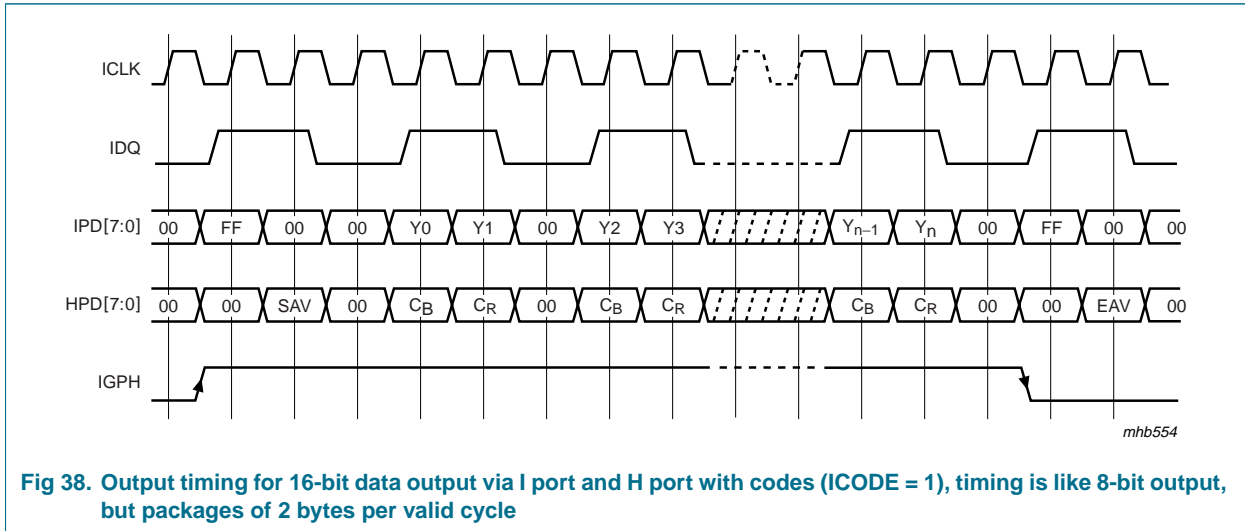

Fig 37. Output timing I port for serial 8-bit data at end of a line (ICODE = 0)



## 10. I<sup>2</sup>C-bus description

The SAA7114 supports the 'fast mode' I<sup>2</sup>C-bus specification extension (data rate up to 400 kbit/s).

### 10.1 I<sup>2</sup>C-bus format

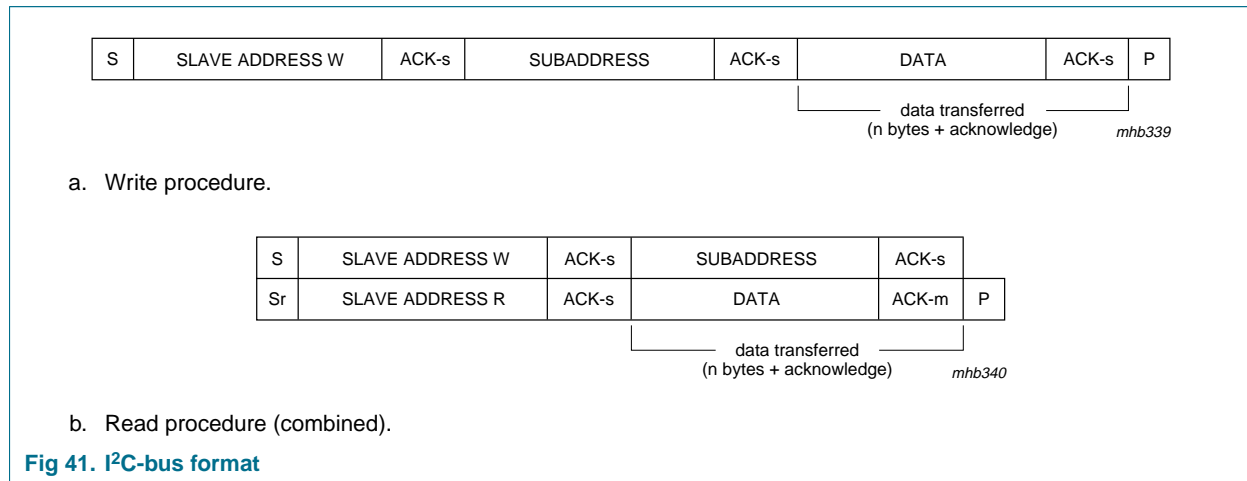

Fig 41. I<sup>2</sup>C-bus format

Table 35: Description of I<sup>2</sup>C-bus format

Code	Description
S	START condition
Sr	repeated START condition
SLAVE ADDRESS W	0100 0010 (42h, default) or 0100 0000 (40h) <sup>[1]</sup>
SLAVE ADDRESS R	0100 0011 (43h, default) or 0100 0001 (41h) <sup>[1]</sup>
ACK-s	acknowledge generated by the slave
ACK-m	acknowledge generated by the master
SUBADDRESS	subaddress byte; see <a href="#">Table 36</a> and <a href="#">Table 37</a>
DATA	data byte; see <a href="#">Table 37</a> ; if more than one byte DATA is transmitted the subaddress pointer is automatically incremented
P	STOP condition

[1] If pin RTCO strapped to supply voltage via a 3.3 kΩ resistor.

Table 36: Subaddress description and access

Subaddress	Description	Access (read/write)
00h	chip version	read only
F0h to FFh	reserved	-
<b>Video decoder: 01h to 2Fh</b>		
01h to 05h	front-end part	read and write
06h to 19h	decoder part	read and write
1Ah to 1Eh	reserved	-
1Fh	video decoder status byte	read only
20h to 2Fh	reserved	-
<b>Audio clock generation: 30h to 3Fh</b>		
30h to 3Ah	audio clock generator	read and write
3Bh to 3Fh	reserved	-
<b>General purpose VBI data slicer: 40h to 7Fh</b>		
40h to 5Eh	VBI data slicer	read and write
5Fh	reserved	-
60h to 62h	VBI data slicer status	read only
63h to 7Fh	reserved	-
<b>X port, I port and the scaler: 80h to EFh</b>		
80h to 8Fh	task independent global settings	read and write
90h to BFh	task A definition	read and write
C0h to EFh	task B definition	read and write

Table 37: I<sup>2</sup>C-bus receiver/transmitter overview

Register function	Subaddress	D7	D6	D5	D4	D3	D2	D1	D0
<b>Chip version: register 00h</b>									
Chip version (read only)	00h	ID7	ID6	ID5	ID4	-	-	-	-
<b>Video decoder: registers 01h to 2Fh</b>									
Front-end part: registers 01h to 05h									
Increment delay	01h	[1]	[1]	[1]	[1]	IDEL3	IDEL2	IDEL1	IDEL0
Analog input control 1	02h	FUSE1	FUSE0	GUDL1	GUDL0	MODE3	MODE2	MODE1	MODE0
Analog input control 2	03h	[1]	HLNRS	VBSL	WPOFF	HOLDG	GAFIX	GAI28	GAI18
Analog input control 3	04h	GAI17	GAI16	GAI15	GAI14	GAI13	GAI12	GAI11	GAI10
Analog input control 4	05h	GAI27	GAI26	GAI25	GAI24	GAI23	GAI22	GAI21	GAI20
Decoder part: registers 06h to 2Fh									
Horizontal sync start	06h	HSB7	HSB6	HSB5	HSB4	HSB3	HSB2	HSB1	HSB0
Horizontal sync stop	07h	HSS7	HSS6	HSS5	HSS4	HSS3	HSS2	HSS1	HSS0
Sync control	08h	AUFD	FSEL	FOET	HTC1	HTC0	HPLL	VNOI1	VNOI0
Luminance control	09h	BYPS	YCOMB	LDEL	LUBW	LUF13	LUF12	LUF11	LUF10
Luminance brightness control	0Ah	DBRI7	DBRI6	DBRI5	DBRI4	DBRI3	DBRI2	DBRI1	DBRI0
Luminance contrast control	0Bh	DCON7	DCON6	DCON5	DCON4	DCON3	DCON2	DCON1	DCON0
Chrominance saturation control	0Ch	DSAT7	DSAT6	DSAT5	DSAT4	DSAT3	DSAT2	DSAT1	DSAT0
Chrominance hue control	0Dh	HUEC7	HUEC6	HUEC5	HUEC4	HUEC3	HUEC2	HUEC1	HUEC0
Chrominance control 1	0Eh	CDTO	CSTD2	CSTD1	CSTD0	DCVF	FCTC	[1]	CCOMB
Chrominance gain control	0Fh	ACGC	CGAIN6	CGAIN5	CGAIN4	CGAIN3	CGAIN2	CGAIN1	CGAIN0
Chrominance control 2	10h	OFFU1	OFFU0	OFFV1	OFFV0	CHBW	LCBW2	LCBW1	LCBW0
Mode/delay control	11h	COLO	RTP1	HDEL1	HDEL0	RTP0	YDEL2	YDEL1	YDEL0
RT signal control	12h	RTSE13	RTSE12	RTSE11	RTSE10	RTSE03	RTSE02	RTSE01	RTSE00
RT/X port output control	13h	RTCE	XRHS	XRVS1	XRVS0	HLSEL	OFTS2	OFTS1	OFTS0
Analog/ADC/compatibility control	14h	CM99	UPTCV	AOSL1	AOSL0	XTOUTE	OLDSB	APCK1	APCK0
VGATE start, FID change	15h	VSTA7	VSTA6	VSTA5	VSTA4	VSTA3	VSTA2	VSTA1	VSTA0
VGATE stop	16h	VSTO7	VSTO6	VSTO5	VSTO4	VSTO3	VSTO2	VSTO1	VSTO0
Miscellaneous, VGATE configuration and MSBs	17h	LLCE	LLC2E	[1]	[1]	[1]	VGPS	VSTO8	VSTA8
Raw data gain control	18h	RAWG7	RAWG6	RAWG5	RAWG4	RAWG3	RAWG2	RAWG1	RAWG0
Raw data offset control	19h	RAWO7	RAWO6	RAWO5	RAWO4	RAWO3	RAWO2	RAWO1	RAWO0

Table 37: I<sup>2</sup>C-bus receiver/transmitter overview ...continued

Register function	Subaddress	D7	D6	D5	D4	D3	D2	D1	D0
Reserved	1Ah to 1Eh	[1]	[1]	[1]	[1]	[1]	[1]	[1]	[1]
Status byte video decoder (read only, OLDSB = 0)	1Fh	INTL	HLVLN	FIDT	GLIMIT	GLIMB	WIPA	COPRO	RDCAP
Status byte video decoder (read only, OLDSB = 1)	1Fh	INTL	HLCK	FIDT	GLIMIT	GLIMB	WIPA	SLTCA	CODE
Reserved	20h to 2Fh	[1]	[1]	[1]	[1]	[1]	[1]	[1]	[1]
<b>Audio clock generator part: registers 30h to 3Fh</b>									
Audio master clock cycles per field	30h	ACPF7	ACPF6	ACPF5	ACPF4	ACPF3	ACPF2	ACPF1	ACPF0
	31h	ACPF15	ACPF14	ACPF13	ACPF12	ACPF11	ACPF10	ACPF9	ACPF8
	32h	[1]	[1]	[1]	[1]	[1]	[1]	ACPF17	ACPF16
Reserved	33h	[1]	[1]	[1]	[1]	[1]	[1]	[1]	[1]
Audio master clock nominal increment	34h	ACNI7	ACNI6	ACNI5	ACNI4	ACNI3	ACNI2	ACNI1	ACNI0
	35h	ACNI15	ACNI14	ACNI13	ACNI12	ACNI11	ACNI10	ACNI9	ACNI8
	36h	[1]	[1]	ACNI21	ACNI20	ACNI19	ACNI18	ACNI17	ACNI16
Reserved	37h	[1]	[1]	[1]	[1]	[1]	[1]	[1]	[1]
Clock ratio AMXCLK to ASCLK	38h	[1]	[1]	SDIV5	SDIV4	SDIV3	SDIV2	SDIV1	SDIV0
Clock ratio ASCLK to ALRCLK	39h	[1]	[1]	LRDIV5	LRDIV4	LRDIV3	LRDIV2	LRDIV1	LRDIV0
Audio clock generator basic setup	3Ah	[1]	[1]	[1]	[1]	APLL	AMVR	LRPH	SCPH
Reserved	3Bh to 3Fh	[1]	[1]	[1]	[1]	[1]	[1]	[1]	[1]
<b>General purpose VBI data slicer part: registers 40h to 7Fh</b>									
Slicer control 1	40h	[1]	HAM_N	FCE	HUNT_N	[1]	[1]	[1]	[1]
LCR2 to LCR24 (n = 2 to 24)	41h to 57h	LCRn_7	LCRn_6	LCRn_5	LCRn_4	LCRn_3	LCRn_2	LCRn_1	LCRn_0
Programmable framing code	58h	FC7	FC6	FC5	FC4	FC3	FC2	FC1	FC0
Horizontal offset for slicer	59h	HOFF7	HOFF6	HOFF5	HOFF4	HOFF3	HOFF2	HOFF1	HOFF0
Vertical offset for slicer	5Ah	VOFF7	VOFF6	VOFF5	VOFF4	VOFF3	VOFF2	VOFF1	VOFF0
Field offset and MSBs for horizontal and vertical offset	5Bh	FOFF	RECODE	[1]	VOFF8	[1]	HOFF10	HOFF9	HOFF8
Reserved (for testing)	5Ch	[1]	[1]	[1]	[1]	[1]	[1]	[1]	[1]
Header and data identification (DID) code control	5Dh	FVREF	[1]	DID5	DID4	DID3	DID2	DID1	DID0
Sliced data identification (SDID) code	5Eh	[1]	[1]	SDID5	SDID4	SDID3	SDID2	SDID1	SDID0
Reserved	5Fh	[1]	[1]	[1]	[1]	[1]	[1]	[1]	[1]

Table 37: I<sup>2</sup>C-bus receiver/transmitter overview ...continued

Register function	Subaddress	D7	D6	D5	D4	D3	D2	D1	D0
Slicer status byte 0 (read only)	60h	-	FC8V	FC7V	VPSV	PPV	CCV	-	-
Slicer status byte 1 (read only)	61h	-	-	F21_N	LN8	LN7	LN6	LN5	LN4
Slicer status byte 2 (read only)	62h	LN3	LN2	LN1	LN0	DT3	DT2	DT1	DT0
Reserved	63h to 7Fh	<a href="#">[1]</a>	<a href="#">[1]</a>	<a href="#">[1]</a>	<a href="#">[1]</a>	<a href="#">[1]</a>	<a href="#">[1]</a>	<a href="#">[1]</a>	<a href="#">[1]</a>
<b>X port, I port and the scaler part: registers 80h to EFh</b>									
Task independent global settings: 80h to 8Fh									
Global control 1	80h	<a href="#">[1]</a>	SMOD	TEB	TEA	ICKS3	ICKS2	ICKS1	ICKS0
Reserved	81h and 82h	<a href="#">[1]</a>	<a href="#">[1]</a>	<a href="#">[1]</a>	<a href="#">[1]</a>	<a href="#">[1]</a>	<a href="#">[1]</a>	<a href="#">[1]</a>	<a href="#">[1]</a>
X port I/O enable and output clock phase control	83h	<a href="#">[1]</a>	<a href="#">[1]</a>	XPCK1	XPCK0	<a href="#">[1]</a>	XRQT	XPE1	XPE0
I port signal definitions	84h	IDG01	IDG00	IDG11	IDG10	IDV1	IDV0	IDH1	IDH0
I port signal polarities	85h	ISWP1	ISWP0	ILLV	IGOP	IG1P	IRVP	IRHP	IDQP
I port FIFO flag control and arbitration	86h	VITX1	VITX0	IDG02	IDG12	FFL1	FFL0	FEL1	FEL0
I port I/O enable, output clock and gated clock phase control	87h	IPCK3	IPCK2	IPCK1	IPCK0	<a href="#">[1]</a>	<a href="#">[1]</a>	IPE1	IPE0
Power save control	88h	CH4EN	CH2EN	SWRST	DPROG	SLM3	<a href="#">[1]</a>	SLM1	SLM0
Reserved	89h to 8Eh	<a href="#">[1]</a>	<a href="#">[1]</a>	<a href="#">[1]</a>	<a href="#">[1]</a>	<a href="#">[1]</a>	<a href="#">[1]</a>	<a href="#">[1]</a>	<a href="#">[1]</a>
Status information scaler part	8Fh	XTRI	ITRI	FFIL	FFOV	PRDON	ERROF	FIDSCI	FIDSCO
Task A definition: registers 90h to BFh									
Basic settings and acquisition window definition									
Task handling control	90h	CONLH	OFIDC	FSKP2	FSKP1	FSKP0	RPTSK	STRC1	STRC0
X port formats and configuration	91h	CONLV	HLDFV	SCSRC1	SCSRC0	SCRQE	FSC2	FSC1	FSC0
X port input reference signal definitions	92h	XFDV	XFDH	XDV1	XDV0	XCODE	XDH	XDQ	XCKS
I port output formats and configuration	93h	ICODE	I8_16	FYSK	FOI1	FOI0	FSI2	FSI1	FSI0
Horizontal input window start	94h	XO7	XO6	XO5	XO4	XO3	XO2	XO1	XO0
	95h	<a href="#">[1]</a>	<a href="#">[1]</a>	<a href="#">[1]</a>	<a href="#">[1]</a>	XO11	XO10	XO9	XO8
Horizontal input window length	96h	XS7	XS6	XS5	XS4	XS3	XS2	XS1	XS0
	97h	<a href="#">[1]</a>	<a href="#">[1]</a>	<a href="#">[1]</a>	<a href="#">[1]</a>	XS11	XS10	XS9	XS8
Vertical input window start	98h	YO7	YO6	YO5	YO4	YO3	YO2	YO1	YO0
	99h	<a href="#">[1]</a>	<a href="#">[1]</a>	<a href="#">[1]</a>	<a href="#">[1]</a>	YO11	YO10	YO9	YO8



Table 37: I<sup>2</sup>C-bus receiver/transmitter overview ...continued

Register function	Subaddress	D7	D6	D5	D4	D3	D2	D1	D0
Vertical input window length	9Ah	YS7	YS6	YS5	YS4	YS3	YS2	YS1	YS0
	9Bh	<a href="#">1</a>	<a href="#">1</a>	<a href="#">1</a>	<a href="#">1</a>	YS11	YS10	YS9	YS8
Horizontal output window length	9Ch	XD7	XD6	XD5	XD4	XD3	XD2	XD1	XD0
	9Dh	<a href="#">1</a>	<a href="#">1</a>	<a href="#">1</a>	<a href="#">1</a>	XD11	XD10	XD9	XD8
Vertical output window length	9Eh	YD7	YD6	YD5	YD4	YD3	YD2	YD1	YD0
	9Fh	<a href="#">1</a>	<a href="#">1</a>	<a href="#">1</a>	<a href="#">1</a>	YD11	YD10	YD9	YD8
<i>FIR filtering and prescaling</i>									
Horizontal prescaling	A0h	<a href="#">1</a>	<a href="#">1</a>	XPSC5	XPSC4	XPSC3	XPSC2	XPSC1	XPSC0
Accumulation length	A1h	<a href="#">1</a>	<a href="#">1</a>	XACL5	XACL4	XACL3	XACL2	XACL1	XACL0
Prescaler DC gain and FIR prefilter control	A2h	PFUV1	PFUV0	PFY1	PFY0	XC2_1	XDCG2	XDCG1	XDCG0
Reserved	A3h	<a href="#">1</a>	<a href="#">1</a>	<a href="#">1</a>	<a href="#">1</a>	<a href="#">1</a>	<a href="#">1</a>	<a href="#">1</a>	<a href="#">1</a>
Luminance brightness control	A4h	BRIG7	BRIG6	BRIG5	BRIG4	BRIG3	BRIG2	BRIG1	BRIG0
Luminance contrast control	A5h	CONT7	CONT6	CONT5	CONT4	CONT3	CONT2	CONT1	CONT0
Chrominance saturation control	A6h	SATN7	SATN6	SATN5	SATN4	SATN3	SATN2	SATN1	SATN0
Reserved	A7h	<a href="#">1</a>	<a href="#">1</a>	<a href="#">1</a>	<a href="#">1</a>	<a href="#">1</a>	<a href="#">1</a>	<a href="#">1</a>	<a href="#">1</a>
<i>Horizontal phase scaling</i>									
Horizontal luminance scaling increment	A8h	XSCY7	XSCY6	XSCY5	XSCY4	XSCY3	XSCY2	XSCY1	XSCY0
	A9h	<a href="#">1</a>	<a href="#">1</a>	<a href="#">1</a>	XSCY12	XSCY11	XSCY10	XSCY9	XSCY8
Horizontal luminance phase offset	AAh	XPHY7	XPHY6	XPHY5	XPHY4	XPHY3	XPHY2	XPHY1	XPHY0
Reserved	ABh	<a href="#">1</a>	<a href="#">1</a>	<a href="#">1</a>	<a href="#">1</a>	<a href="#">1</a>	<a href="#">1</a>	<a href="#">1</a>	<a href="#">1</a>
Horizontal chrominance scaling increment	ACH	XSCC7	XSCC6	XSCC5	XSCC4	XSCC3	XSCC2	XSCC1	XSCC0
	ADh	<a href="#">1</a>	<a href="#">1</a>	<a href="#">1</a>	XSCC12	XSCC11	XSCC10	XSCC9	XSCC8
Horizontal chrominance phase offset	Aeh	XPHC7	XPHC6	XPHC5	XPHC4	XPHC3	XPHC2	XPHC1	XPHC0
Reserved	Afh	<a href="#">1</a>	<a href="#">1</a>	<a href="#">1</a>	<a href="#">1</a>	<a href="#">1</a>	<a href="#">1</a>	<a href="#">1</a>	<a href="#">1</a>
<i>Vertical scaling</i>									
Vertical luminance scaling increment	B0h	YSCY7	YSCY6	YSCY5	YSCY4	YSCY3	YSCY2	YSCY1	YSCY0
	B1h	YSCY15	YSCY14	YSCY13	YSCY12	YSCY11	YSCY10	YSCY9	YSCY8
Vertical chrominance scaling increment	B2h	YSCC7	YSCC6	YSCC5	YSCC4	YSCC3	YSCC2	YSCC1	YSCC0
	B3h	YSCC15	YSCC14	YSCC13	YSCC12	YSCC11	YSCC10	YSCC9	YSCC8
Vertical scaling mode control	B4h	<a href="#">1</a>	<a href="#">1</a>	<a href="#">1</a>	YMIR	<a href="#">1</a>	<a href="#">1</a>	<a href="#">1</a>	YMODE
Reserved	B5h to B7h	<a href="#">1</a>	<a href="#">1</a>	<a href="#">1</a>	<a href="#">1</a>	<a href="#">1</a>	<a href="#">1</a>	<a href="#">1</a>	<a href="#">1</a>

Table 37: I<sup>2</sup>C-bus receiver/transmitter overview ...continued

Register function	Subaddress	D7	D6	D5	D4	D3	D2	D1	D0
Vertical chrominance phase offset '00'	B8h	YPC07	YPC06	YPC05	YPC04	YPC03	YPC02	YPC01	YPC00
Vertical chrominance phase offset '01'	B9h	YPC17	YPC16	YPC15	YPC14	YPC13	YPC12	YPC11	YPC10
Vertical chrominance phase offset '10'	BAh	YPC27	YPC26	YPC25	YPC24	YPC23	YPC22	YPC21	YPC20
Vertical chrominance phase offset '11'	BBh	YPC37	YPC36	YPC35	YPC34	YPC33	YPC32	YPC31	YPC30
Vertical luminance phase offset '00'	BCh	YPY07	YPY06	YPY05	YPY04	YPY03	YPY02	YPY01	YPY00
Vertical luminance phase offset '01'	BDh	YPY17	YPY16	YPY15	YPY14	YPY13	YPY12	YPY11	YPY10
Vertical luminance phase offset '10'	BEh	YPY27	YPY26	YPY25	YPY24	YPY23	YPY22	YPY21	YPY20
Vertical luminance phase offset '11'	BFh	YPY37	YPY36	YPY35	YPY34	YPY33	YPY32	YPY31	YPY30
Task B definition registers C0h to EFh									
<i>Basic settings and acquisition window definition</i>									
Task handling control	C0h	CONLH	OFIDC	FSKP2	FSKP1	FSKP0	RPTSK	STRC1	STRC0
X port formats and configuration	C1h	CONLV	HLDFV	SCSRC1	SCSRC0	SCRQE	FSC2	FSC1	FSC0
Input reference signal definition	C2h	XFDV	XFDH	XDV1	XDV0	XCODE	XDH	XDQ	XCKS
I port formats and configuration	C3h	ICODE	I8_16	FYSK	FOI1	FOI0	FSI2	FSI1	FSI0
Horizontal input window start	C4h	XO7	XO6	XO5	XO4	XO3	XO2	XO1	XO0
	C5h	[1]	[1]	[1]	[1]	XO11	XO10	XO9	XO8
Horizontal input window length	C6h	XS7	XS6	XS5	XS4	XS3	XS2	XS1	XS0
	C7h	[1]	[1]	[1]	[1]	XS11	XS10	XS9	XS8
Vertical input window start	C8h	YO7	YO6	YO5	YO4	YO3	YO2	YO1	YO0
	C9h	[1]	[1]	[1]	[1]	YO11	YO10	YO9	YO8
Vertical input window length	CAh	YS7	YS6	YS5	YS4	YS3	YS2	YS1	YS0
	CBh	[1]	[1]	[1]	[1]	YS11	YS10	YS9	YS8
Horizontal output window length	CCh	XD7	XD6	XD5	XD4	XD3	XD2	XD1	XD0
	CDh	[1]	[1]	[1]	[1]	XD11	XD10	XD9	XD8
Vertical output window length	CEh	YD7	YD6	YD5	YD4	YD3	YD2	YD1	YD0
	CFh	[1]	[1]	[1]	[1]	YD11	YD10	YD9	YD8
<i>FIR filtering and prescaling</i>									
Horizontal prescaling	D0h	[1]	[1]	XPSC5	XPSC4	XPSC3	XPSC2	XPSC1	XPSC0
Accumulation length	D1h	[1]	[1]	XACL5	XACL4	XACL3	XACL2	XACL1	XACL0
Prescaler DC gain and FIR prefilter control	D2h	PFUV1	PFUV0	PFY1	PFY0	XC2_1	XDCG2	XDCG1	XDCG0
Reserved	D3h	[1]	[1]	[1]	[1]	[1]	[1]	[1]	[1]

Table 37: I<sup>2</sup>C-bus receiver/transmitter overview ...continued

Register function	Subaddress	D7	D6	D5	D4	D3	D2	D1	D0
Luminance brightness control	D4h	BRIG7	BRIG6	BRIG5	BRIG4	BRIG3	BRIG2	BRIG1	BRIG0
Luminance contrast control	D5h	CONT7	CONT6	CONT5	CONT4	CONT3	CONT2	CONT1	CONT0
Chrominance saturation control	D6h	SATN7	SATN6	SATN5	SATN4	SATN3	SATN2	SATN1	SATN0
Reserved	D7h	[1]	[1]	[1]	[1]	[1]	[1]	[1]	[1]
<i>Horizontal phase scaling</i>									
Horizontal luminance scaling increment	D8h	XSCY7	XSCY6	XSCY5	XSCY4	XSCY3	XSCY2	XSCY1	XSCY0
	D9h	[1]	[1]	[1]	XSCY12	XSCY11	XSCY10	XSCY9	XSCY8
Horizontal luminance phase offset	DAh	XPHY7	XPHY6	XPHY5	XPHY4	XPHY3	XPHY2	XPHY1	XPHY0
Reserved	DBh	[1]	[1]	[1]	[1]	[1]	[1]	[1]	[1]
Horizontal chrominance scaling increment	DCh	XSCC7	XSCC6	XSCC5	XSCC4	XSCC3	XSCC2	XSCC1	XSCC0
	DDh	[1]	[1]	[1]	XSCC12	XSCC11	XSCC10	XSCC9	XSCC8
Horizontal chrominance phase offset	DEh	XPHC7	XPHC6	XPHC5	XPHC4	XPHC3	XPHC2	XPHC1	XPHC0
Reserved	DFh	[1]	[1]	[1]	[1]	[1]	[1]	[1]	[1]
<i>Vertical scaling</i>									
Vertical luminance scaling increment	E0h	YSCY7	YSCY6	YSCY5	YSCY4	YSCY3	YSCY2	YSCY1	YSCY0
	E1h	YSCY15	YSCY14	YSCY13	YSCY12	YSCY11	YSCY10	YSCY9	YSCY8
Vertical chrominance scaling increment	E2h	YSCC7	YSCC6	YSCC5	YSCC4	YSCC3	YSCC2	YSCC1	YSCC0
	E3h	YSCC15	YSCC14	YSCC13	YSCC12	YSCC11	YSCC10	YSCC9	YSCC8
Vertical scaling mode control	E4h	[1]	[1]	[1]	YMIR	[1]	[1]	[1]	YMODE
Reserved	E5h to E7h	[1]	[1]	[1]	[1]	[1]	[1]	[1]	[1]
Vertical chrominance phase offset '00'	E8h	YPC07	YPC06	YPC05	YPC04	YPC03	YPC02	YPC01	YPC00
Vertical chrominance phase offset '01'	E9h	YPC17	YPC16	YPC15	YPC14	YPC13	YPC12	YPC11	YPC10
Vertical chrominance phase offset '10'	EAh	YPC27	YPC26	YPC25	YPC24	YPC23	YPC22	YPC21	YPC20
Vertical chrominance phase offset '11'	EBh	YPC37	YPC36	YPC35	YPC34	YPC33	YPC32	YPC31	YPC30
Vertical luminance phase offset '00'	ECh	YPY07	YPY06	YPY05	YPY04	YPY03	YPY02	YPY01	YPY00
Vertical luminance phase offset '01'	EDh	YPY17	YPY16	YPY15	YPY14	YPY13	YPY12	YPY11	YPY10
Vertical luminance phase offset '10'	EEh	YPY27	YPY26	YPY25	YPY24	YPY23	YPY22	YPY21	YPY20
Vertical luminance phase offset '11'	EFh	YPY37	YPY36	YPY35	YPY34	YPY33	YPY32	YPY31	YPY30

[1] All unused control bits must be programmed with logic 0 to ensure compatibility to future enhancements.

## 10.2 I<sup>2</sup>C-bus details

### 10.2.1 Subaddress 00h

Table 38: Chip Version (CV) identification; 00h[7:4]; read only register

Function	Logic levels			
	ID7	ID6	ID5	ID4
Chip Version (CV)	CV3	CV2	CV1	CV0

### 10.2.2 Subaddress 01h

The programming of the horizontal increment delay is used to match internal processing delays to the delay of the ADC. Use recommended position only.

Table 39: Horizontal increment delay; 01h[3:0]

Function	IDEL3	IDEL2	IDEL1	IDEL0
No update	1	1	1	1
Minimum delay	1	1	1	0
<b>Recommended position</b>	<b>1</b>	<b>0</b>	<b>0</b>	<b>0</b>
Maximum delay	0	0	0	0

### 10.2.3 Subaddress 02h

Table 40: Analog input control 1 (AICO1); 02h[7:0]

Bit	Description	Symbol	Value	Function
D[7:6]	analog function select; see <a href="#">Figure 5</a>	FUSE[1:0]	00	amplifier plus anti-alias filter bypassed
			01	amplifier plus anti-alias filter bypassed
			10	amplifier active
			11	amplifier plus anti-alias filter active
D[5:4]	update hysteresis for 9-bit gain; see <a href="#">Figure 8</a>	GUDL[1:0]	00	off
			01	±1 LSB
			10	±2 LSB
			11	±3 LSB

Table 40: Analog input control 1 (AICO1); 02h[7:0] ...continued

Bit	Description	Symbol	Value	Function
D[3:0]	mode selection	MODE[3:0]	0000	<b>Mode 0:</b> CVBS (automatic gain) from AI11; see <a href="#">Figure 42</a>
			0001	<b>Mode 1:</b> CVBS (automatic gain) from AI12; see <a href="#">Figure 43</a>
			0010	<b>Mode 2:</b> CVBS (automatic gain) from AI21; see <a href="#">Figure 44</a>
			0011	<b>Mode 3:</b> CVBS (automatic gain) from AI22; see <a href="#">Figure 45</a>
			0100	<b>Mode 4:</b> CVBS (automatic gain) from AI23; see <a href="#">Figure 46</a>
			0101	<b>Mode 5:</b> CVBS (automatic gain) from AI24; see <a href="#">Figure 47</a>
			0110	<b>Mode 6:</b> Y (automatic gain) from AI11 + C (gain adjustable via GAI28 to GAI20) from AI21 <sup>[1]</sup> ; see <a href="#">Figure 48</a>
			0111	<b>Mode 7:</b> Y (automatic gain) from AI12 + C (gain adjustable via GAI28 to GAI20) from AI22 <sup>[1]</sup> ; see <a href="#">Figure 49</a>
			1000	<b>Mode 8:</b> Y (automatic gain) from AI11 + C (gain adapted to Y gain) from AI21 <sup>[1]</sup> ; see <a href="#">Figure 50</a>
			1001	<b>Mode 9:</b> Y (automatic gain) from AI12 + C (gain adapted to Y gain) from AI22 <sup>[1]</sup> ; see <a href="#">Figure 51</a>
			1010 to 1111	<b>Modes 10 to 15:</b> reserved

[1] To take full advantage of the Y/C modes 6 to 9 the I<sup>2</sup>C-bus bit BYPS (subaddress 09h, bit D7) should be set to logic 1 (full luminance bandwidth).

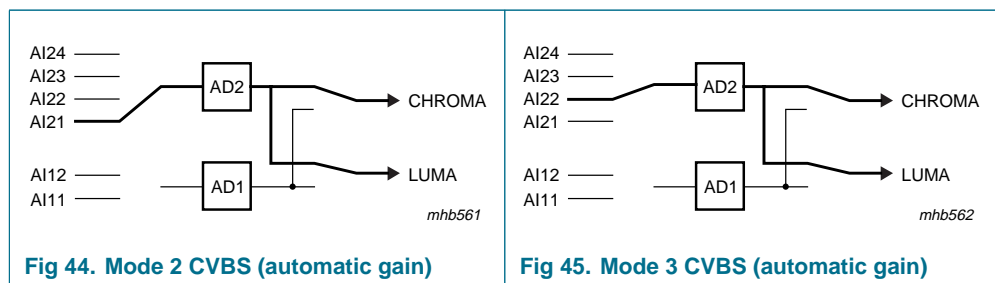
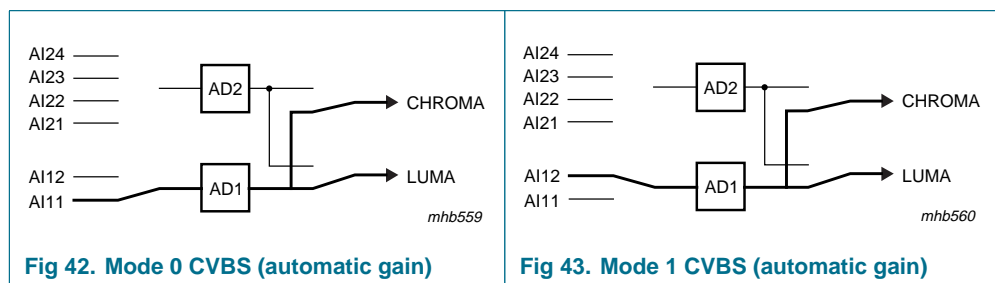

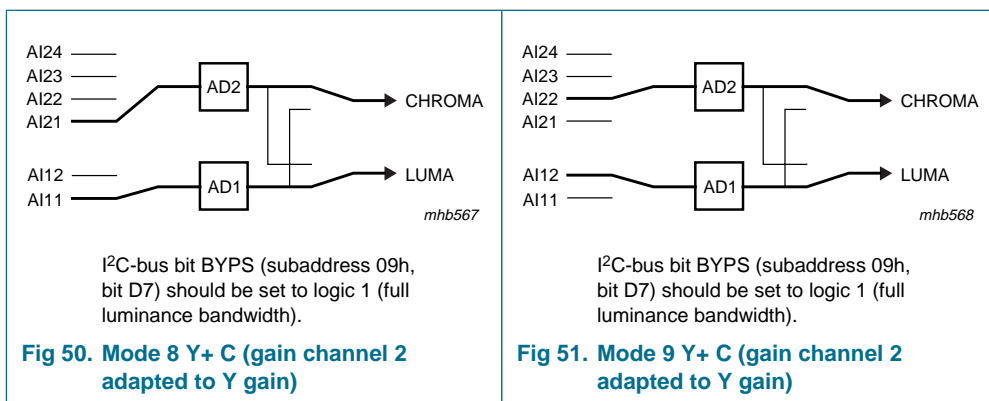
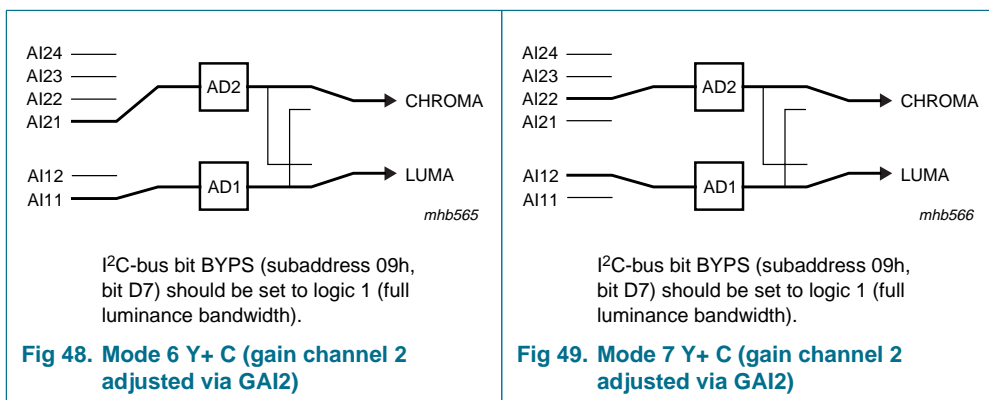
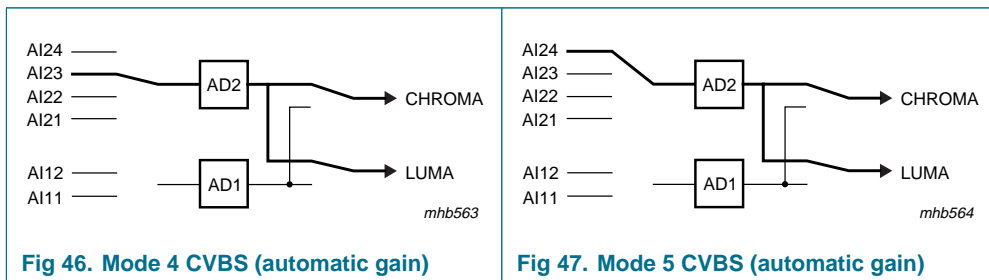

10.2.4 Subaddress 03h

Table 41: Analog input control 2 (AICO2); 03h[6:0]

Bit	Description	Symbol	Value	Function
D6	HL not reference select	HLNRS	0	normal clamping if decoder is in unlocked state
			1 <sup>[1]</sup>	reference select if decoder is in unlocked state
D5	AGC hold during vertical blanking period	VBSL	0	short vertical blanking (AGC disabled during equalization and serration pulses)
			1	long vertical blanking (AGC disabled from start of pre-equalization pulses until start of active video (line 22 for 60 Hz, line 24 for 50 Hz))
D4	white peak control off	WPOFF	0 <sup>[1]</sup>	white peak control active
			1	white peak control off

**Table 41: Analog input control 2 (AICO2); 03h[6:0] ...continued**

Bit	Description	Symbol	Value	Function
D3	automatic gain control integration	HOLDG	0	AGC active
			1	AGC integration hold (freeze)
D2	gain control fix	GAFIX	0	automatic gain controlled by MODE3 to MODE0
			1	gain is user programmable via GAI[17:10] and GAI[27:20]
D1	static gain control channel 2 sign bit	GAI28	see <a href="#">Table 43</a>	
D0	static gain control channel 1 sign bit	GAI18	see <a href="#">Table 42</a>	

[1] HLNRS = 1 should not be used in combination with WPOFF = 0.

### 10.2.5 Subaddress 04h

**Table 42: Analog input control 3 (AICO3): static gain control channel 1; 03h[0] and 04h[7:0]**

Decimal value	Gain (dB)	Sign bit 03h[0]	Control bits D7 to D0								
			GAI18	GAI17	GAI16	GAI15	GAI14	GAI13	GAI12	GAI11	GAI10
0...	-3	0	0	0	0	0	0	0	0	0	0
...144	0	0	1	0	0	1	0	0	0	0	0
145...	0	0	1	0	0	1	0	0	0	0	1
...511	+6	1	1	1	1	1	1	1	1	1	1

### 10.2.6 Subaddress 05h

**Table 43: Analog input control 4 (AICO4); static gain control channel 2; 03h[1] and 05h[7:0]**

Decimal value	Gain (dB)	Sign bit 03h[1]	Control bits D7 to D0								
			GAI28	GAI27	GAI26	GAI25	GAI24	GAI23	GAI22	GAI21	GAI20
0...	-3	0	0	0	0	0	0	0	0	0	0
...144	0	0	1	0	0	1	0	0	0	0	0
145...	0	0	1	0	0	1	0	0	0	0	1
...511	+6	1	1	1	1	1	1	1	1	1	1

### 10.2.7 Subaddress 06h

**Table 44: Horizontal sync start; 06h[7:0]**

Delay time (step size = 8/LLC)	Control bits D7 to D0							
	HSB7	HSB6	HSB5	HSB4	HSB3	HSB2	HSB1	HSB0
-128...-109 (50 Hz)	forbidden (outside available central counter range)							
-128...-108 (60 Hz)	forbidden (outside available central counter range)							
-108 (50 Hz)...	1	0	0	1	0	1	0	0
-107 (60 Hz)...	1	0	0	1	0	1	0	1
...108 (50 Hz)	0	1	1	0	1	1	0	0

Table 44: Horizontal sync start; 06h[7:0] ...continued

Delay time (step size = 8/LLC)	Control bits D7 to D0							
	HSB7	HSB6	HSB5	HSB4	HSB3	HSB2	HSB1	HSB0
...107 (60 Hz)	0	1	1	0	1	0	1	1
109...127 (50 Hz)	forbidden (outside available central counter range)							
108...127 (60 Hz)	forbidden (outside available central counter range)							

## 10.2.8 Subaddress 07h

Table 45: Horizontal sync stop; 07h[7:0]

Delay time (step size = 8/LLC)	Control bits D7 to D0							
	HSS7	HSS6	HSS5	HSS4	HSS3	HSS2	HSS1	HSS0
-128...-109 (50 Hz)	forbidden (outside available central counter range)							
-128...-108 (60 Hz)	forbidden (outside available central counter range)							
-108 (50 Hz)...	1	0	0	1	0	1	0	0
-107 (60 Hz)...	1	0	0	1	0	1	0	1
...108 (50 Hz)	0	1	1	0	1	1	0	0
...107 (60 Hz)	0	1	1	0	1	0	1	1
109...127 (50 Hz)	forbidden (outside available central counter range)							
108...127 (60 Hz)	forbidden (outside available central counter range)							

## 10.2.9 Subaddress 08h

Table 46: Sync control; 08h[7:0]

Bit	Description	Symbol	Value	Function
D7	automatic field detection	AUPD	0	field state directly controlled via FSEL
			1	automatic field detection; <b>recommended setting</b>
D6	field selection; active if AUPD = 0	FSEL	0	50 Hz, 625 lines
			1	60 Hz, 525 lines
D5	forced ODD/EVEN toggle	FOET	0	ODD/EVEN signal toggles only with interlaced source
			1	ODD/EVEN signal toggles fieldwise even if source is non-interlaced
D[4:3]	horizontal time constant selection	HTC[1:0]	00	TV mode, recommended for poor quality TV signals only; do not use for new applications
			01	VTR mode, recommended if a deflection control circuit is directly connected to the SAA7114
			10	reserved
			11	fast locking mode; <b>recommended setting</b>
D2	horizontal PLL	HPLL	0	PLL closed
			1	PLL open; horizontal frequency fixed



Table 46: Sync control; 08h[7:0] ...continued

Bit	Description	Symbol	Value	Function
D[1:0]	vertical noise reduction	VNOI[1:0]	00	normal mode; <b>recommended setting</b>
			01	fast mode, applicable for stable sources only; automatic field detection (AUFD) <b>must</b> be disabled
			10	free running mode
			11	vertical noise reduction bypassed

### 10.2.10 Subaddress 09h

Table 47: Luminance control; 09h[7:0]

Bit	Description	Symbol	Value	Function
D7	chrominance trap/comb filter bypass	BYPS	0	chrominance trap or luminance comb filter active; default for CVBS mode
			1	chrominance trap or luminance comb filter bypassed; default for S-video mode
D6	adaptive luminance comb filter	YCOMB	0	disabled (= chrominance trap enabled, if BYPS = 0)
			1	active, if BYPS = 0
D5	processing delay in non comb filter mode	LDEL	0	processing delay is equal to internal pipe-lining delay
			1	one (NTSC standards) or two (PAL standards) video lines additional processing delay
D4	remodulation bandwidth for luminance; see <a href="#">Figure 13</a> to <a href="#">Figure 16</a>	LUBW	0	small remodulation bandwidth (narrow chroma notch $\Rightarrow$ higher luminance bandwidth)
			1	large remodulation bandwidth (wider chroma notch $\Rightarrow$ smaller luminance bandwidth)

Table 47: Luminance control; 09h[7:0] ...continued

Bit	Description	Symbol	Value	Function
D[3:0]	sharpness control, luminance filter characteristic; see <a href="#">Figure 17</a>	LUF1[3:0]	0001	resolution enhancement filter 8.0 dB at 4.1 MHz
			0010	resolution enhancement filter 6.8 dB at 4.1 MHz
			0011	resolution enhancement filter 5.1 dB at 4.1 MHz
			0100	resolution enhancement filter 4.1 dB at 4.1 MHz
			0101	resolution enhancement filter 3.0 dB at 4.1 MHz
			0110	resolution enhancement filter 2.3 dB at 4.1 MHz
			0111	resolution enhancement filter 1.6 dB at 4.1 MHz
			0000	plain
			1000	low-pass filter 2 dB at 4.1 MHz
			1001	low-pass filter 3 dB at 4.1 MHz
			1010	low-pass filter 3 dB at 3.3 MHz; 4 dB at 4.1 MHz
			1011	low-pass filter 3 dB at 2.6 MHz; 8 dB at 4.1 MHz
			1100	low-pass filter 3 dB at 2.4 MHz; 14 dB at 4.1 MHz
			1101	low-pass filter 3 dB at 2.2 MHz; notch at 3.4 MHz
			1110	low-pass filter 3 dB at 1.9 MHz; notch at 3.0 MHz
			1111	low-pass filter 3 dB at 1.7 MHz; notch at 2.5 MHz

### 10.2.11 Subaddress 0Ah

Table 48: Luminance brightness control: decoder part; 0Ah[7:0]

Offset	Control bits D7 to D0							
	DBR17	DBR16	DBR15	DBR14	DBR13	DBR12	DBR11	DBR10
255 (bright)	1	1	1	1	1	1	1	1
128 (ITU level)	1	0	0	0	0	0	0	0
0 (dark)	0	0	0	0	0	0	0	0

## 10.2.12 Subaddress 0Bh

Table 49: Luminance contrast control: decoder part; 0Bh[7:0]

Gain	Control bits D7 to D0							
	DCON7	DCON6	DCON5	DCON4	DCON3	DCON2	DCON1	DCON0
1.984 (maximum)	0	1	1	1	1	1	1	1
1.063 (ITU level)	0	1	0	0	0	1	0	0
1.0	0	1	0	0	0	0	0	0
0 (luminance off)	0	0	0	0	0	0	0	0
-1 (inverse luminance)	1	1	0	0	0	0	0	0
-2 (inverse luminance)	1	0	0	0	0	0	0	0

## 10.2.13 Subaddress 0Ch

Table 50: Chrominance saturation control: decoder part; 0Ch[7:0]

Gain	Control bits D7 to D0							
	DSAT7	DSAT6	DSAT5	DSAT4	DSAT3	DSAT2	DSAT1	DSAT0
1.984 (maximum)	0	1	1	1	1	1	1	1
1.0 (ITU level)	0	1	0	0	0	0	0	0
0 (color off)	0	0	0	0	0	0	0	0
-1 (inverse chrominance)	1	1	0	0	0	0	0	0
-2 (inverse chrominance)	1	0	0	0	0	0	0	0

## 10.2.14 Subaddress 0Dh

Table 51: Chrominance hue control; 0Dh[7:0]

Hue phase (deg)	Control bits D7 to D0							
	HUEC7	HUEC6	HUEC5	HUEC4	HUEC3	HUEC2	HUEC1	HUEC0
+178.6...	0	1	1	1	1	1	1	1
...0...	0	0	0	0	0	0	0	0
...-180	1	0	0	0	0	0	0	0

## 10.2.15 Subaddress 0Eh

Table 52: Chrominance control 1; 0Eh[7:0]

Bit	Description	Symbol	Value	Function
D7	clear DTO	CDTO	0	disabled
			1	Every time CDTO is set, the internal subcarrier DTO phase is reset to 0° and the RTCO output generates a logic 0 at time slot 68 (see document "RTC Functional Description", available on request). So an identical subcarrier phase can be generated by an external device (e.g. an encoder); if a DTO reset is programmed via CDTO it has always to be executed in the following order: <ol style="list-style-type: none"> <li>1. Set CDTO = 0</li> <li>2. Set CDTO = 1</li> </ol>
D[6:4]	color standard selection	CSTD[2:0]	000	50 Hz/625 lines: PAL BGDHI (4.43 MHz) 60 Hz/525 lines: NTSC M (3.58 MHz)
			001	50 Hz/625 lines: NTSC 4.43 (50 Hz) 60 Hz/525 lines: PAL 4.43 (60 Hz)
			010	50 Hz/625 lines: combination-PAL N (3.58 MHz) 60 Hz/525 lines: NTSC 4.43 (60 Hz)
			011	50 Hz/625 lines: NTSC N (3.58 MHz) 60 Hz/525 lines: PAL M (3.58 MHz)
			100	50 Hz/625 lines: reserved 60 Hz/525 lines: NTSC-Japan (3.58 MHz)
			101	50 Hz/625 lines: SECAM 60 Hz/525 lines: reserved
			110	reserved; <b>do not use</b>
			111	reserved; <b>do not use</b>
D3	disable chrominance vertical filter and PAL phase error correction	DCVF	0	chrominance vertical filter and PAL phase error correction on (during active video lines)
			1	chrominance vertical filter and PAL phase error correction permanently off
D2	fast color time constant	FCTC	0	nominal time constant
			1	fast time constant for special applications (high quality input source, fast chroma lock required, automatic standard detection off)
D0	adaptive chrominance comb filter	CCOMB	0	disabled
			1	active

## 10.2.16 Subaddress 0Fh

Table 53: Chrominance gain control; 0Fh[7:0]

Bit	Description	Symbol	Value	Function
D7	automatic chrominance gain control	ACGC	0	on
			1	programmable gain via CGAIN6 to CGAIN0; need to be set for SECAM standard
D[6:0]	chrominance gain value (if ACGC is set to logic 1)	CGAIN[6:0]	000 0000	minimum gain (0.5)
			010 0100	nominal gain (1.125)
			111 1111	maximum gain (7.5)

## 10.2.17 Subaddress 10h

Table 54: Chrominance control 2; 10h[7:0]

Bit	Description	Symbol	Value	Function
D[7:6]	fine offset adjustment B – Y component	OFFU[1:0]	00	0 LSB
			01	1/4 LSB
			10	1/2 LSB
			11	3/4 LSB
D[5:4]	fine offset adjustment R – Y component	OFFV[1:0]	00	0 LSB
			01	1/4 LSB
			10	1/2 LSB
			11	3/4 LSB
D3	chrominance bandwidth; see <a href="#">Figure 11</a> and <a href="#">Figure 12</a>	CHBW	0	small
			1	wide
D[2:0]	combined luminance/chrominance bandwidth adjustment; see <a href="#">Figure 11</a> to <a href="#">Figure 17</a>	LCBW[2:0]	000	smallest chrominance bandwidth/largest luminance bandwidth
			...	... to ...
			111	largest chrominance bandwidth/smallest luminance bandwidth

## 10.2.18 Subaddress 11h

Table 55: Mode/delay control; 11h[7:0]

Bit	Description	Symbol	Value	Function
D7	color on	COLO	0	automatic color killer enabled
			1	color forced on
D6	polarity of RTS1 output signal	RTP1	0	non-inverted
			1	inverted
D[5:4]	fine position of HS (steps in 2/LLC)	HDEL[1:0]	00	0
			01	1
			10	2
			11	3

**Table 55: Mode/delay control; 11h[7:0] ...continued**

Bit	Description	Symbol	Value	Function
D3	polarity of RTS0 output signal	RTP0	0	non-inverted
			1	inverted
D[2:0]	luminance delay compensation (steps in 2/LLC)	YDEL[2:0]	100	-4...
			000	...0...
			011	...3

### 10.2.19 Subaddress 12h

**Table 56: RT signal control: RTS0 output; 12h[3:0]**

The polarity of any signal on RTS0 can be inverted via RTP0[11h[3]].

RTS0 output	RTSE03	RTSE02	RTSE01	RTSE00
3-state	0	0	0	0
Constant LOW	0	0	0	1
CREF (13.5 MHz toggling pulse; see <a href="#">Figure 26</a> )	0	0	1	0
CREF2 (6.75 MHz toggling pulse; see <a href="#">Figure 26</a> )	0	0	1	1
HL; horizontal lock indicator <a href="#">[1]</a> : HL = 0: unlocked HL = 1: locked	0	1	0	0
VL; vertical and horizontal lock: VL = 0: unlocked VL = 1: locked	0	1	0	1
DL; vertical and horizontal lock and color detected: DL = 0: unlocked DL = 1: locked	0	1	1	0
Reserved	0	1	1	1
HREF, horizontal reference signal; indicates 720 pixels valid data on the expansion port. The positive slope marks the beginning of a new active line. HREF is also generated during the vertical blanking interval (see <a href="#">Figure 26</a> ).	1	0	0	0
HS: Programmable width in LLC8 steps via HSB[7:0] 06h[7:0] and HSS[7:0] 07h[7:0] Fine position adjustment in LLC2 steps via HDEL[1:0] 11h[5:4] (see <a href="#">Figure 26</a> )	1	0	0	1
HQ; HREF gated with VGATE	1	0	1	0
Reserved	1	0	1	1
V123; vertical sync (see vertical timing diagrams <a href="#">Figure 24</a> and <a href="#">Figure 25</a> )	1	1	0	0
VGATE; programmable via VSTA[8:0] 17h[0] 15h[7:0], VSTO[8:0] 17h[1] 16h[7:0] and VGPS[17h[2]]	1	1	0	1
LSBs of the 9-bit ADCs	1	1	1	0
FID; position programmable via VSTA[8:0] 17h[0] 15h[7:0]; see vertical timing diagrams <a href="#">Figure 24</a> and <a href="#">Figure 25</a>	1	1	1	1

- [1] Function of HL is selectable via HLSEL[13h[3]]:
- a) HLSEL = 0: HL is standard horizontal lock indicator.
  - b) HLSEL = 1: HL is fast horizontal lock indicator (use is not recommended for sources with unstable timebase e.g. VCRs).

**Table 57: RT signal control: RTS1 output; 12h[7:4]**

The polarity of any signal on RTS1 can be inverted via RTP1[11h[6]].

RTS1 output	RTSE13	RTSE12	RTSE11	RTSE10
3-state	0	0	0	0
Constant LOW	0	0	0	1
CREF (13.5 MHz toggling pulse; see <a href="#">Figure 26</a> )	0	0	1	0
CREF2 (6.75 MHz toggling pulse; see <a href="#">Figure 26</a> )	0	0	1	1
HL; horizontal lock indicator <sup>[1]</sup> :	0	1	0	0
HL = 0: unlocked				
HL = 1: locked				
VL; vertical and horizontal lock:	0	1	0	1
VL = 0: unlocked				
VL = 1: locked				
DL; vertical and horizontal lock and color detected:	0	1	1	0
DL = 0: unlocked				
DL = 1: locked				
Reserved	0	1	1	1
HREF, horizontal reference signal; indicates 720 pixels valid data on the expansion port. The positive slope marks the beginning of a new active line. HREF is also generated during the vertical blanking interval (see <a href="#">Figure 26</a> ).	1	0	0	0
HS:	1	0	0	1
Programmable width in LLC8 steps via HSB[7:0] 06h[7:0] and HSS[7:0] 07h[7:0]				
Fine position adjustment in LLC2 steps via HDEL[1:0] 11h[5:4] (see <a href="#">Figure 26</a> )				
HQ; HREF gated with VGATE	1	0	1	0
Reserved	1	0	1	1
V123; vertical sync (see vertical timing diagrams <a href="#">Figure 24</a> and <a href="#">Figure 25</a> )	1	1	0	0
VGATE; programmable via VSTA[8:0] 17h[0] 15h[7:0], VSTO[8:0] 17h[1] 16h[7:0] and VGPS[17h[2]]	1	1	0	1
Reserved	1	1	1	0
FID; position programmable via VSTA[8:0] 17h[0] 15h[7:0]; see vertical timing diagrams <a href="#">Figure 24</a> and <a href="#">Figure 25</a>	1	1	1	1

- [1] Function of HL is selectable via HLSEL[13h[3]]:
- HLSEL = 0: HL is standard horizontal lock indicator.
  - HLSEL = 1: HL is fast horizontal lock indicator (use is not recommended for sources with unstable timebase e.g. VCRs).

## 10.2.20 Subaddress 13h

Table 58: RT/X port output control; 13h[7:0]

Bit	Description	Symbol	Value	Function
D7	RTCO output enable	RTCE	0	3-state
			1	enabled
D6	X port XRH output selection	XRHS	0	HREF (see <a href="#">Figure 26</a> )
			1	HS: Programmable width in LLC8 steps via HSB[7:0] 06h[7:0] and HSS[7:0] 07h[7:0] Fine position adjustment in LLC2 steps via HDEL[1:0] 11h[5:4] (see <a href="#">Figure 26</a> )
D[5:4]	X port XRV output selection	XRVS[1:0]	00	V123 (see <a href="#">Figure 24</a> and <a href="#">Figure 25</a> )
			01	ITU 656 related field ID (see <a href="#">Figure 24</a> and <a href="#">Figure 25</a> )
			10	inverted V123
			11	inverted ITU 656 related field ID
D3	horizontal lock indicator selection	HLSEL	0	copy of inverted HLCK status bit (default)
			1	fast horizontal lock indicator (for special applications only)
D[2:0]	XPD7 to XPD0 (port output format selection); see <a href="#">Section 9.4</a>	OFTS[2:0]	000	ITU 656
			001	ITU 656 like format with modified field blanking according to VGATE position (programmable via VSTA[8:0] 17h[0] 15h[7:0], VSTO[8:0] 17h[1] 16h[7:0] and VGPS[17h[2]])
			010	Y-C <sub>B</sub> -C <sub>R</sub> 4 : 2 : 2 8-bit format (no SAV/EAV codes inserted)
			011	reserved
			100	multiplexed AD2/AD1 bypass (bits D8 to D1) dependent on mode settings (see <a href="#">Section 10.2.3</a> ); if both ADCs are selected AD2 is output at CREF = 1 and AD1 is output at CREF = 0
			101	multiplexed AD2/AD1 bypass (bits D7 to D0) dependent on mode settings (see <a href="#">Section 10.2.3</a> ); if both ADCs are selected AD2 is output at CREF = 1 and AD1 is output at CREF = 0
110	reserved		110	reserved
			111	multiplexed ADC MSB/LSB bypass dependent on mode settings; only one ADC should be selected at a time; ADx8 to ADx1 are outputs at CREF = 1 and ADx7 to ADx0 are outputs at CREF = 0



## 10.2.21 Subaddress 14h

Table 59: Analog/ADC/compatibility control; 14h[7:0]

Bit	Description	Symbol	Value	Function
D7	compatibility bit for SAA7199	CM99	0	off (default)
			1	on (to be set <b>only</b> if SAA7199 is used for re-encoding <b>in conjunction with RTCO active</b> )
D6	update time interval for AGC value	UPTCV	0	horizontal update (once per line)
			1	vertical update (once per field)
D[5:4]	analog test select	AOSL[1:0]	00	AOUT connected to internal test point 1
			01	AOUT connected to input AD1
			10	AOUT connected to input AD2
			11	AOUT connected to internal test point 2
D3	XTOUT output enable	XTOUTE	0	XTOUT 3-stated
			1	XTOUT enabled
D2	decoder status byte selection; see <a href="#">Table 65</a>	OLDSB	0	standard
			1	backward compatibility to SAA7112
D[1:0]	ADC sample clock phase delay	APCK[1:0]	00	application dependent
			01	application dependent
			10	application dependent
			11	application dependent

## 10.2.22 Subaddress 15h

Table 60: VGATE start; FID polarity change; 17h[0] and 15h[7:0]

Start of VGATE pulse (LOW-to-HIGH transition) and polarity change of FID pulse, VGPS = 0; see [Figure 24](#) and [Figure 25](#).

Field	Frame line counting	Decimal value	MSB 17h[0]	Control bits D7 to D0								
				VSTA8	VSTA7	VSTA6	VSTA5	VSTA4	VSTA3	VSTA2	VSTA1	VSTA0
50 Hz	1st	1	312	1	0	0	1	1	1	0	0	0
	2nd	314										
	1st	2	0...	0	0	0	0	0	0	0	0	0
	2nd	315										
60 Hz	1st	312	...310	1	0	0	1	1	0	1	1	1
	2nd	625										
	1st	4	262	1	0	0	0	0	0	1	1	0
	2nd	267										
	1st	5	0...	0	0	0	0	0	0	0	0	0
	2nd	268										
	1st	265	...260	1	0	0	0	0	0	1	0	1
	2nd	3										

### 10.2.23 Subaddress 16h

**Table 61: VGATE stop; 17h[1] and 16h[7:0]**

Stop of VGATE pulse (HIGH-to-LOW transition), VGPS = 0; see [Figure 24](#) and [Figure 25](#).

Field	Frame line counting	Decimal value	MSB 17h[1]	Control bits D7 to D0								
			VSTO8	VSTO7	VSTO6	VSTO5	VSTO4	VSTO3	VSTO2	VSTO1	VSTO0	
50 Hz	1st	1	312	1	0	0	1	1	1	0	0	0
	2nd	314										
	1st	2	0...	0	0	0	0	0	0	0	0	0
	2nd	315										
	1st	312	...310	1	0	0	1	1	0	1	1	1
	2nd	625										
60 Hz	1st	4	262	1	0	0	0	0	0	1	1	0
	2nd	267										
	1st	5	0...	0	0	0	0	0	0	0	0	0
	2nd	268										
	1st	265	...260	1	0	0	0	0	0	1	0	1
	2nd	3										

### 10.2.24 Subaddress 17h

**Table 62: Miscellaneous/VGATE MSBs; 17h[7:6] and 17h[2:0]**

Bit	Description	Symbol	Value	Function
D7	LLC output enable	LLCE	0	enable
			1	3-state
D6	LLC2 output enable	LLC2E	0	enable
			1	3-state
D2	alternative VGATE position	VGPS	0	VGATE position according to <a href="#">Table 60</a> and <a href="#">Table 61</a>
			1	VGATE occurs one line earlier during field 2
D1	MSB VGATE stop	VSTO8	see <a href="#">Table 61</a>	
D0	MSB VGATE start	VSTA8	see <a href="#">Table 60</a>	

### 10.2.25 Subaddress 18h

**Table 63: Raw data gain control; RAWG[7:0]18h[7:0]; see [Figure 19](#)**

Gain	Control bits D7 to D0							
	RAWG7	RAWG6	RAWG5	RAWG4	RAWG3	RAWG2	RAWG1	RAWG0
255 (double amplitude)	0	1	1	1	1	1	1	1
128 (nominal level)	0	1	0	0	0	0	0	0
0 (off)	0	0	0	0	0	0	0	0

## 10.2.26 Subaddress 19h

Table 64: Raw data offset control; RAWO[7:0] 19h[7:0]; see Figure 19

Offset	Control bits D7 to D0							
	RAWO7	RAWO6	RAWO5	RAWO4	RAWO3	RAWO2	RAWO1	RAWO0
-128 LSB	0	0	0	0	0	0	0	0
0 LSB	1	0	0	0	0	0	0	0
+128 LSB	1	1	1	1	1	1	1	1

## 10.2.27 Subaddress 1Fh

Table 65: Status byte video decoder; 1Fh[7:0]; read only register

Bit	Description	I <sup>2</sup> C-bus control bit	OLDSB 14h[2]	Value	Function
D7	status bit for interlace detection	INTL	-	0	non-interlaced
				1	interlaced
D6	status bit for horizontal and vertical loop	HLVLN	0	0	both loops locked
				1	unlocked
	status bit for locked horizontal frequency	HLCK	1	0	locked
				1	unlocked
D5	identification bit for detected field frequency	FIDT	-	0	50 Hz
				1	60 Hz
D4	gain value for active luminance channel is limited; maximum (top)	GLIMT	-	0	not active
				1	active
D3	gain value for active luminance channel is limited; minimum (bottom)	GLIMB	-	0	not active
				1	active
D2	white peak loop is activated	WIPA	-	0	not active
				1	active
D1	copy protected source detected according to Macrovision version up to 7.01	COPRO	0	0	not active
				1	active
	slow time constant active in WIPA mode	SLTCA	1	0	not active
D0	ready for capture (all internal loops locked)	RDCAP	0	0	not active
				1	active
	color signal in accordance with selected standard has been detected	CODE	1	0	not active
				1	active

### 10.3 Programming register audio clock generation

See equations in [Section 8.6](#) and examples in [Table 22](#) and [Table 23](#).

#### 10.3.1 Subaddresses 30h to 32h

Table 66: Audio master clock (AMCLK) cycles per field

Subaddress	Control bits D7 to D0							
30h	ACPF7	ACPF6	ACPF5	ACPF4	ACPF3	ACPF2	ACPF1	ACPF0
31h	ACPF15	ACPF14	ACPF13	ACPF12	ACPF11	ACPF10	ACPF9	ACPF8
32h	-	-	-	-	-	-	ACPF17	ACPF16

#### 10.3.2 Subaddresses 34h to 36h

Table 67: Audio master clock (AMCLK) nominal increment

Subaddress	Control bits D7 to D0							
34h	ACNI7	ACNI6	ACNI5	ACNI4	ACNI3	ACNI2	ACNI1	ACNI0
35h	ACNI15	ACNI14	ACNI13	ACNI12	ACNI11	ACNI10	ACNI9	ACNI8
36h	-	-	ACNI21	ACNI20	ACNI19	ACNI18	ACNI17	ACNI16

#### 10.3.3 Subaddress 38h

Table 68: Clock ratio audio master clock (AMXCLK) to serial bit clock (ASCLK)

Subaddress	Control bits D7 to D0							
38h	-	-	SDIV5	SDIV4	SDIV3	SDIV2	SDIV1	SDIV0

#### 10.3.4 Subaddress 39h

Table 69: Clock ratio serial bit clock (ASCLK) to channel select clock (ALRCLK)

Subaddress	Control bits D7 to D0							
39h	-	-	LRDIV5	LRDIV4	LRDIV3	LRDIV2	LRDIV1	LRDIV0

#### 10.3.5 Subaddress 3Ah

Table 70: Audio clock control; 3Ah[3:0]

Bit	Description	Symbol	Value	Function
D3	audio PLL modes	APLL	0	PLL active, AMCLK is field-locked
			1	PLL open, AMCLK is free-running
D2	audio master clock vertical reference	AMVR	0	vertical reference pulse is taken from internal decoder
			1	vertical reference is taken from XRV input (expansion port)
D1	ALRCLK phase	LRPH	0	ALRCLK edges triggered by falling edges of ASCLK
			1	ALRCLK edges triggered by rising edges of ASCLK
D0	ASCLK phase	SCPH	0	ASCLK edges triggered by falling edges of AMCLK
			1	ASCLK edges triggered by rising edges of AMCLK

## 10.4 Programming register VBI data slicer

### 10.4.1 Subaddress 40h

Table 71: Slicer control 1; 40h[6:4]

Bit	Description	Symbol	Value	Function
D6	Hamming check	HAM_N	0	<b>Hamming check for 2 bytes after framing code, dependent on data type (default)</b>
			1	no Hamming check
D5	framing code error	FCE	0	one framing code error allowed
			1	no framing code errors allowed
D4	amplitude searching	HUNT_N	0	<b>amplitude searching active (default)</b>
			1	amplitude searching stopped

### 10.4.2 Subaddresses 41h to 57h

Table 72: Line control register; LCR2 to LCR24 (41h to 57h)

See [Section 8.2](#) and [Section 8.4](#).

Name	Description	Framing code	D[7:4] (41h to 57h)	D[3:0] (41h to 57h)
			DT[3:0] 62h[3:0] (field 1)	DT[3:0] 62h[3:0] (field 2)
WST625	teletext EuroWST, CCST	27h	0000	0000
CC625	European closed caption	001	0001	0001
VPS	video programming service	9951h	0010	0010
WSS	wide screen signalling bits	1E 3C1Fh	0011	0011
WST525	US teletext (WST)	27h	0100	0100
CC525	US closed caption (line 21)	001	0101	0101
Test line	video component signal, VBI region	-	0110	0110
Intercast	raw data	-	0111	0111
General text	teletext	programmable	1000	1000
VITC625	VITC/EBU time codes (Europe)	programmable	1001	1001
VITC525	VITC/SMPTE time codes (USA)	programmable	1010	1010
Reserved	reserved	-	1011	1011
NABTS	US NABTS	-	1100	1100
Japtext	MOJI (Japanese)	programmable (A7h)	1101	1101
JFS	Japanese format switch (L20/22)	programmable	1110	1110
Active video	<b>video component signal, active video region (default)</b>	-	1111	1111

### 10.4.3 Subaddress 58h

**Table 73: Programmable framing code; slicer set 58h[7:0]**

According to [Table 15](#) and [Table 72](#).

Framing code for programmable data types	Control bits D7 to D0
Default value	FC[7:0] = 40h

### 10.4.4 Subaddress 59h

**Table 74: Horizontal offset for slicer; slicer set 59h and 5Bh**

Horizontal offset	Control bits 5Bh[2:0]	Control bits 59h[7:0]
Recommended value	HOFF[10:8] = 3h	HOFF[7:0] = 47h

### 10.4.5 Subaddress 5Ah

**Table 75: Vertical offset for slicer; slicer set 5Ah and 5Bh**

Vertical offset	Control bit 5Bh[4]	Control bits 5Ah[7:0]
	VOFF8	VOFF[7:0]
Minimum value 0	0	00h
Maximum value 312	1	38h
Value for 50 Hz 625 lines input	0	03h
Value for 60 Hz 525 lines input	0	06h

### 10.4.6 Subaddress 5Bh

**Table 76: Field offset, and MSBs for horizontal and vertical offsets; slicer set 5Bh[7:6]**

See [Section 10.4.4](#) and [Section 10.4.5](#) for HOFF[10:8] 5Bh[2:0] and VOFF8[5Bh[4]].

Bit	Description	Symbol	Value	Function
D7	field offset	FOFF	0	no modification of internal field indicator (default for 50 Hz 625 lines input sources)
			1	invert field indicator (default for 60 Hz 525 lines input sources)
D6	recode	RECODE	0	<b>leave data unchanged (default)</b>
			1	convert 00h and FFh data bytes into 03h and FCh

### 10.4.7 Subaddress 5Dh

**Table 77: Header and data identification (DID; ITU 656) code control; slicer set 5Dh[7:0]**

Bit	Description	Symbol	Value	Function
D7	field ID and V-blank selection for text output (F and V reference selection)	FVREF	0	F and V output of slicer is LCR table dependent
			1	F and V output is taken from decoder real-time signals EVEN_ITU and VBLNK_ITU
D[5:0]	default; DID[5:0] = 00h  special cases of DID programming	DID[5:0]	00 0000	<b>ANC header framing; see <a href="#">Figure 33</a> and <a href="#">Table 21</a></b>
			11 1110	DID[5:0] = 3Eh SAV/EAV framing, with FVREF = 1
			11 1111	DID[5:0] = 3Fh SAV/EAV framing, with FVREF = 0

### 10.4.8 Subaddress 5Eh

Table 78: Sliced data identification (SDID) code; slicer set 5Eh[5:0]

Bit	Description	Symbol	Value	Function
D[5:0]	SDID codes	SDID[5:0]	00h	default

### 10.4.9 Subaddress 60h

Table 79: Slicer status byte 0; 60h[6:2]; read only register

Bit	Description	Symbol	Value	Function
D6	framing code valid	FC8V	0	no framing code (0 error) in the last frame detected
			1	framing code with 0 error detected
D5	framing code valid	FC7V	0	no framing code (1 error) in the last frame detected
			1	framing code with 1 error detected
D4	VPS valid	VPSV	0	no VPS in the last frame
			1	VPS detected
D3	PALplus valid	PPV	0	no PALplus in the last frame
			1	PALplus detected
D2	closed caption valid	CCV	0	no closed caption in the last frame
			1	closed caption detected

### 10.4.10 Subaddresses 61h and 62h

Table 80: Slicer status byte 1; 61h[5:0] and slicer status byte 2; 62h[7:0]; read only registers

Subaddress	Bit	Symbol	Description
61h	D5	F21_N	field ID as seen by the VBI slicer; for field 1: D5 = 0
	D[4:0]	LN[8:4]	line number
62h	D[7:4]	LN[3:0]	line number
	D[3:0]	DT[3:0]	data type; according to <a href="#">Table 15</a>

## 10.5 Programming register interfaces and scaler part

### 10.5.1 Subaddress 80h

Table 81: Global control 1; global set 80h[6:4] <sup>[1]</sup>

*SWRST moved to subaddress 88h[5].*

Task enable control	Control bits D6 to D4		
	SMOD	TEB	TEA
Task of register set A is disabled	X	X	0
Task of register set A is enabled	X	X	1
Task of register set B is disabled	X	0	X
Task of register set B is enabled	X	1	X
The scaler window defines the F and V timing of the scaler output	0	X	X
VBI data slicer defines the F and V timing of the scaler output	1	X	X

[1] X = don't care.

**Table 82: Global control 1; global set 80h[3:0]** [\[1\]](#)

I port and scaler back-end clock selection	Control bits D3 to D0			
	ICKS3	ICKS2	ICKS1	ICKS0
ICLK output and back-end clock is line-locked clock LLC from decoder	X	X	0	0
ICLK output and back-end clock is XCLK from X port	X	X	0	1
ICLK output is LLC and back-end clock is LLC2 clock	X	X <a href="#">[2]</a>	1	0
Back-end clock is the ICLK input	X	X	1	1
IDQ pin carries the data qualifier	X	0	X	X
IDQ pin carries a gated back-end clock (DQ AND CLK)	X	1	X	X
IDQ generation only for valid data	0	X	X	X
IDQ qualifies valid data inside the scaling region and all data outside the scaling region	1	X	X	X

[1] X = don't care.

[2] Although the ICLKO I/O is independent of ICKS2 and ICKS3, this selection can only be used if ICKS2 = 1.

## 10.5.2 Subaddresses 83h to 87h

**Table 83: X port I/O enable and output clock phase control; global set 83h[5:4]**

Output clock phase control	Control bits D5 and D4	
	XPCK1	XPCK0
<b>XCLK default output phase, recommended value</b>	0	0
XCLK output inverted	0	1
XCLK phase shifted by approximately 3 ns	1	0
XCLK output inverted and shifted by approximately 3 ns	1	1

**Table 84: X port I/O enable and output clock phase control; global set 83h[2:0]** [\[1\]](#)

X port I/O enable	Control bits D2 to D0		
	XRQT	XPE1	XPE0
X port output is disabled by software	X	0	0
X port output is enabled by software	X	0	1
X port output is enabled by pin XTRI at logic 0	X	1	0
X port output is enabled by pin XTRI at logic 1	X	1	1
XRDY output signal is A/B task flag from event handler (A = 1)	0	X	X
XRDY output signal is ready signal from scaler path (XRDY = 1 means the SAA7114 is ready to receive data)	1	X	X

[1] X = don't care.



Table 85: I port signal definitions; global set 84h[7:6] and 86h[5]

I port signal definitions	Control bits		
	86h[5]	84h[7:6]	
	IDG02	IDG01	IDG00
IGP0 is output field ID, as defined by OFIDC[90h[6]]	0	0	0
IGP0 is A/B task flag, as defined by CONLH[90h[7]]	0	0	1
IGP0 is sliced data flag, framing the sliced VBI data at the I port	0	1	0
<b>IGP0 is set to logic 0 (default polarity)</b>	0	1	1
IGP0 is the output FIFO almost filled flag	1	0	0
IGP0 is the output FIFO overflow flag	1	0	1
IGP0 is the output FIFO almost full flag, level to be programmed in subaddress 86h	1	1	0
IGP0 is the output FIFO almost empty flag, level to be programmed in subaddress 86h	1	1	1

Table 86: I port signal definitions; global set 84h[5:4] and 86h[4]

I port signal definitions	Control bits		
	86h[4]	84h[5:4]	
	IDG12	IDG11	IDG10
IGP1 is output field ID, as defined by OFIDC[90h[6]]	0	0	0
IGP1 is A/B task flag, as defined by CONLH[90h[7]]	0	0	1
IGP1 is sliced data flag, framing the sliced VBI data at the I port	0	1	0
<b>IGP1 is set to logic 0 (default polarity)</b>	0	1	1
IGP1 is the output FIFO almost filled flag	1	0	0
IGP1 is the output FIFO overflow flag	1	0	1
IGP1 is the output FIFO almost full flag, level to be programmed in subaddress 86h	1	1	0
IGP1 is the output FIFO almost empty flag, level to be programmed in subaddress 86h	1	1	1

Table 87: I port output signal definitions; global set 84h[3:0] [1]

I port output signal definitions	Control bits D3 to D0			
	IDV1	IDV0	IDH1	IDH0
IGPH is a H gate signal, framing the scaler output	X	X	0	0
IGPH is an extended H gate (framing H gate during scaler output and scaler input H reference outside the scaler window)	X	X	0	1
IGPH is a horizontal trigger pulse, on active going edge of H gate	X	X	1	0
IGPH is a horizontal trigger pulse, on active going edge of extended H gate	X	X	1	1
IGPV is a V gate signal, framing scaled output lines	0	0	X	X
IGPV is the V reference signal from scaler input	0	1	X	X
IGPV is a vertical trigger pulse, derived from V gate	1	0	X	X
IGPV is a vertical trigger pulse derived from input V reference	1	1	X	X

[1] X = don't care.

Table 88: X port signal definitions text slicer; global set 85h[7:5] [1]

X port signal definitions text slicer	Control bits D7 to D5		
	ISWP1	ISWP0	ILLV
Video data limited to range 1 to 254	X	X	0
Video data limited to range 8 to 247	X	X	1
Dword byte swap, influences serial output timing D0 D1 D2 D3 ⇒ FF 00 00 SAV C <sub>B0</sub> Y0 C <sub>R0</sub> Y1	0	0	X
D1 D0 D3 D2 ⇒ 00 FF SAV 00 Y0 C <sub>B0</sub> Y1 C <sub>R0</sub>	0	1	X
D2 D3 D0 D1 ⇒ 00 SAV FF 00 C <sub>R0</sub> Y1 C <sub>B0</sub> Y0	1	0	X
D3 D2 D1 D0 ⇒ SAV 00 00 FF Y1 C <sub>R0</sub> Y0 C <sub>B0</sub>	1	1	X

[1] X = don't care.

Table 89: I port reference signal polarities; global set 85h[4:0] [1]

I port reference signal polarities	Control bits D4 to D0				
	IG0P	IG1P	IRVP	IRHP	IDQP
IDQ at default polarity (1 = active)	X	X	X	X	0
IDQ is inverted	X	X	X	X	1
IGPH at default polarity (1 = active)	X	X	X	0	X
IGPH is inverted	X	X	X	1	X
IGPV at default polarity (1 = active)	X	X	0	X	X
IGPV is inverted	X	X	1	X	X
IGP1 at default polarity	X	0	X	X	X
IGP1 is inverted	X	1	X	X	X
IGP0 at default polarity	0	X	X	X	X
IGP0 is inverted	1	X	X	X	X

[1] X = don't care.

Table 90: I port FIFO flag control and arbitration; global set 86h[7:4] [1]

Function	Control bits D7 to D4			
	VITX1	VITX0	IDG02	IDG12
See subaddress 84h: IDG11 and IDG10	X	X	X	0
	X	X	X	1
See subaddress 84h: IDG01 and IDG00	X	X	0	X
	X	X	1	X
<b>I port signal definitions</b>				
I port data output inhibited	0	0	X	X
Only video data is transferred	0	1	X	X
Only text data is transferred (no EAV, SAV will occur)	1	0	X	X
Text and video data is transferred, text has priority	1	1	X	X

[1] X = don't care.

Table 91: I port FIFO flag control and arbitration; global set 86h[3:0] [1]

I port FIFO flag control and arbitration	Control bits D3 to D0			
	FFL1	FFL0	FEL1	FEL0
FAE FIFO flag almost empty level				
< 16 Dwords	X	X	0	0
< 8 Dwords	X	X	0	1
< 4 Dwords	X	X	1	0
0 Dwords	X	X	1	1
FAF FIFO flag almost full level				
≥ 16 Dwords	0	0	X	X
≥ 24 Dwords	0	1	X	X
≥ 28 Dwords	1	0	X	X
32 Dwords	1	1	X	X

[1] X = don't care.

Table 92: I port I/O enable, output clock and gated clock phase control; global set 87h[7:4] [1]

Output clock and gated clock phase control	Control bits D7 to D4			
	IPCK3 [2]	IPCK2 [2]	IPCK1	IPCK0
ICLK default output phase	X	X	0	0
ICLK phase shifted by $\frac{1}{2}$ clock cycle ⇒ recommended for ICKS1 = 1 and ICKS0 = 0 (subaddress 80h)	X	X	0	1
ICLK phase shifted by approximately 3 ns	X	X	1	0
ICLK phase shifted by $\frac{1}{2}$ clock cycle + approximately 3 ns ⇒ alternatively to setting '01'	X	X	1	1
IDQ = gated clock default output phase	0	0	X	X
IDQ = gated clock phase shifted by $\frac{1}{2}$ clock cycle ⇒ recommended for gated clock output	0	1	X	X
IDQ = gated clock phase shifted by approximately 3 ns	1	0	X	X
IDQ = gated clock phase shifted by $\frac{1}{2}$ clock cycle + approximately 3 ns ⇒ alternatively to setting '01'	1	1	X	X

[1] X = don't care.

[2] IPCK3 and IPCK2 only affects the gated clock (subaddress 80h, bit ICKS2 = 1).

Table 93: I port I/O enable, output clock and gated clock phase control; global set 87h[1:0]

I port I/O enable	Control bits D1 and D0	
	IPE1	IPE0
I port output is disabled by software	0	0
I port output is enabled by software	0	1
I port output is enabled by pin ITRI at logic 0	1	0
I port output is enabled by pin ITRI at logic 1	1	1

### 10.5.3 Subaddress 88h

**Table 94: Power save control; global set 88h[7:4] [1]**

Power save control	Control bits D7 to D4			
	CH4EN	CH2EN	SWRST [2]	DPROG
DPROG = 0 after reset	X	X	X	0
DPROG = 1 can be used to assign that the device has been programmed; this bit can be monitored in the scalers status byte, bit PRDON; if DPROG was set to logic 1 and PRDON status bit shows a logic 0, a power-up or start-up fail has occurred	X	X	X	1
Scaler path is reset to its idle state, software reset	X	X	0	X
Scaler is switched back to operation	X	X	1	X
AD1x analog channel is in Power-down mode	X	0	X	X
AD1x analog channel is active	X	1	X	X
AD2x analog channel is in Power-down mode	0	X	X	X
AD2x analog channel is active	1	X	X	X

[1] X = don't care.

[2] Bit SWRST is now located here.

**Table 95: Power save control; global set 88h[3] and 88h[1:0] [1]**

Power save control	Control bits D3, D1 and D0		
	SLM3	SLM1	SLM0
Decoder and VBI slicer are in operational mode	X	X	0
Decoder and VBI slicer are in Power-down mode; scaler only operates, if scaler input and ICLK source is the X port (refer to subaddresses 80h and 91h/C1h)	X	X	1
Scaler is in operational mode	X	0	X
Scaler is in Power-down mode; scaler in power-down stops I port output	X	1	X
Audio clock generation active	0	X	X
Audio clock generation in power-down and output disabled	1	X	X

[1] X = don't care.

### 10.5.4 Subaddress 8Fh

**Table 96: Status information scaler part; 8Fh[7:0]; read only register**

Bit	I <sup>2</sup> C-bus status bit	Function [1]
D7	XTRI	status on input pin XTRI, if not used for 3-state control, usable as hardware flag for software use
D6	ITRI	status on input pin ITRI, if not used for 3-state control, usable as hardware flag for software use
D5	FFIL	status of the internal 'FIFO almost filled' flag
D4	FFOV	status of the internal 'FIFO overflow' flag
D3	PRDON	copy of bit DPROG, can be used to detect power-up and start-up fails

Table 96: Status information scaler part; 8Fh[7:0]; read only register ...continued

Bit	I <sup>2</sup> C-bus status bit	Function [1]
D2	ERROF	error flag of scalers output formatter, normally set, if the output processing needs to be interrupted, due to input/output data rate conflicts, e.g. if output data rate is much too low and all internal FIFO capacity used
D1	FIDSCI	status of the field sequence ID at the scalers input
D0	FIDSCO	status of the field sequence ID at the scalers output, scaler processing dependent

[1] Status information is unsynchronized and shows the actual status at the time of I<sup>2</sup>C-bus read.

### 10.5.5 Subaddresses 90h and C0h

Table 97: Task handling control; register set A [90h[7:6]] and B [C0h[7:6]] [1]

Event handler control	Control bits D7 and D6	
	CONLH	OFIDC
Output field ID is field ID from scaler input	X	0
Output field ID is task status flag, which changes every time a selected task is activated (not synchronized to input field ID)	X	1
<b>Scaler SAV/EAV byte bit D7 and task flag = 1, default</b>	0	X
Scaler SAV/EAV byte bit D7 and task flag = 0	1	X

[1] X = don't care.

Table 98: Task handling control; register set A [90h[5:3]] and B [C0h[5:3]]

Event handler control	Control bits D5 to D3		
	FSKP2	FSKP1	FSKP0
Active task is carried out directly	0	0	0
1 field is skipped before active task is carried out	0	0	1
... fields are skipped before active task is carried out	...	...	...
6 fields are skipped before active task is carried out	1	1	0
7 fields are skipped before active task is carried out	1	1	1

Table 99: Task handling control; register set A [90h[2:0]] and B [C0h[2:0]] [1]

Event handler control	Control bits D2 to D0		
	RPTSK	STRC1	STRC0
Event handler triggers immediately after finishing a task	X	0	0
Event handler triggers with next V-sync	X	0	1
Event handler triggers with field ID = 0	X	1	0
Event handler triggers with field ID = 1	X	1	1
If active task is finished, handling is taken over by the next task	0	X	X
Active task is repeated once, before handling is taken over by the next task	1	X	X

[1] X = don't care.

## 10.5.6 Subaddresses 91h to 93h

Table 100: X port formats and configuration; register set A [91h[7:3]] and B [C1h[7:3]]<sup>[1]</sup>

Scaler input format and configuration source selection	Control bits D7 to D3				
	CONLV	HLDFV	SCSRC1	SCSRC0	SCRQE
Only if XRQT[83h[2]] = 1: scaler input source reacts on SAA7114 request	X	X	X	X	0
Scaler input source is a continuous data stream, which cannot be interrupted (must be logic 1, if SAA7114 decoder part is source of scaler or XRQT[83h[2]] = 0)	X	X	X	X	1
Scaler input source is data from decoder, data type is provided according to <a href="#">Table 15</a>	X	X	0	0	X
Scaler input source is Y-C <sub>B</sub> -C <sub>R</sub> data from X port	X	X	0	1	X
Scaler input source is raw digital CVBS from selected analog channel, for backward compatibility only, further use is not recommended	X	X	1	0	X
Scaler input source is raw digital CVBS (or 16-bit Y + C <sub>B</sub> -C <sub>R</sub> , if no 16-bit outputs are active) from X port	X	X	1	1	X
SAV/EAV code bits D6 and D5 (F and V) may change between SAV and EAV	X	0	X	X	X
SAV/EAV code bits D6 and D5 (F and V) are synchronized to scalers output line start	X	1	X	X	X
SAV/EAV code bit D5 (V) and V gate on pin IGPV as generated by the internal processing; see <a href="#">Figure 39</a>	0	X	X	X	X
SAV/EAV code bit D5 (V) and V gate are inverted	1	X	X	X	X

[1] X = don't care.

Table 101: X port formats and configuration; register set A [91h[2:0]] and B [C1h[2:0]]<sup>[1]</sup>

Scaler input format and configuration format control	Control bits D2 to D0		
	FSC2 <sup>[2]</sup>	FSC1 <sup>[2]</sup>	FSC0
Input is Y-C <sub>B</sub> -C <sub>R</sub> 4 : 2 : 2 like sampling scheme	X	X	0
Input is Y-C <sub>B</sub> -C <sub>R</sub> 4 : 1 : 1 like sampling scheme	X	X	1
<b>Chroma is provided every line, default</b>	0	0	X
Chroma is provided every 2nd line	0	1	X
Chroma is provided every 3rd line	1	0	X
Chroma is provided every 4th line	1	1	X

[1] X = don't care.

[2] FSC2 and FSC1 only to be used if X port input source does not provide chroma information for every input line. X port input stream must contain dummy chroma bytes.

**Table 102: X port input reference signal definitions; register set A [92h[7:4]] and B [C2h[7:4]]** [\[1\]](#)

X port input reference signal definitions	Control bits D7 to D4			
	XFDV	XFDH	XDV1	XDV0
Rising edge of XRV input and decoder V123 is vertical reference	X	X	X	0
Falling edge of XRV input and decoder V123 is vertical reference	X	X	X	1
XRV is a V-sync or V gate signal	X	X	0	X
XRV is a frame sync, V pulses are generated internally on both edges of FS input	X	X	1	X
X port field ID is state of XRH at reference edge on XRV (defined by XFDV)	X	0	X	X
Field ID (decoder and X port field ID) is inverted	X	1	X	X
Reference edge for field detection is falling edge of XRV	0	X	X	X
Reference edge for field detection is rising edge of XRV	1	X	X	X

[1] X = don't care.

**Table 103: X port input reference signal definitions; register set A [92h[3:0]] and B [C2h[3:0]]** [\[1\]](#)

X port input reference signal definitions	Control bits D3 to D0			
	XCODE	XDH	XDQ	XCKS
XCLK input clock and XDQ input qualifier are needed	X	X	X	0
Data rate is defined by XCLK only, no XDQ signal used	X	X	X	1
Data are qualified at XDQ input at logic 1	X	X	0	X
Data are qualified at XDQ input at logic 0	X	X	1	X
Rising edge of XRH input is horizontal reference	X	0	X	X
Falling edge of XRH input is horizontal reference	X	1	X	X
Reference signals are taken from XRH and XRV	0	X	X	X
Reference signals are decoded from EAV and SAV	1	X	X	X

[1] X = don't care.

**Table 104: I port output format and configuration; register set A [93h[7:5]] and B [C3h[7:5]]** [\[1\]](#)

I port output formats and configuration	Control bits D7 to D5		
	ICODE	I8_16	FYSK
All lines will be output	X	X	0
Skip the number of leading Y only lines, as defined by FOI1 and FOI0	X	X	1
Dwords are transferred byte wise, see subaddress 85h bits ISWP1 and ISWP0	X	0	X

**Table 104: I port output format and configuration; register set A [93h[7:5]] and B [C3h[7:5]]** [\[1\]](#) ...continued

I port output formats and configuration	Control bits D7 to D5		
	ICODE	IB_16	FYSK
Dwords are transferred 16-bit word wise via IPD and HPD, see subaddress 85h bits ISWP1 and ISWP0	X	1	X
No ITU 656 like SAV/EAV codes are available	0	X	X
ITU 656 like SAV/EAV codes are inserted in the output data stream, framed by a qualifier	1	X	X

[1] X = don't care.

**Table 105: I port output format and configuration; register set A [93h[4:0]] and B [C3h[4:0]]** [\[1\]](#)

I port output formats and configuration	Control bits D4 to D0				
	FOI1	FOI0	FSI2	FSI1	FSI0
4 : 2 : 2 Dword formatting	X	X	0	0	0
4 : 1 : 1 Dword formatting	X	X	0	0	1
4 : 2 : 0, only every 2nd line Y + C <sub>B</sub> -C <sub>R</sub> output, in between Y only output	X	X	0	1	0
4 : 1 : 0, only every 4th line Y + C <sub>B</sub> -C <sub>R</sub> output, in between Y only output	X	X	0	1	1
Y only	X	X	1	0	0
Not defined	X	X	1	0	1
Not defined	X	X	1	1	0
Not defined	X	X	1	1	1
No leading Y only line, before 1st Y + C <sub>B</sub> -C <sub>R</sub> line is output	0	0	X	X	X
1 leading Y only line, before 1st Y + C <sub>B</sub> -C <sub>R</sub> line is output	0	1	X	X	X
2 leading Y only lines, before 1st Y + C <sub>B</sub> -C <sub>R</sub> line is output	1	0	X	X	X
3 leading Y only lines, before 1st Y + C <sub>B</sub> -C <sub>R</sub> line is output	1	1	X	X	X

[1] X = don't care.



10.5.7 Subaddresses 94h to 9Bh

Table 106: Horizontal input window start; register set A [94h[7:0]; 95h[3:0]] and B [C4h[7:0]; C5h[3:0]]

Horizontal input acquisition window definition offset in X (horizontal) direction [1]	Control bits											
	A [95h[3:0]] and B [C5h[3:0]]				A [94h[7:0]] and B [C4h[7:0]]							
	XO11	XO10	XO9	XO8	XO7	XO6	XO5	XO4	XO3	XO2	XO1	XO0
A minimum of '2' should be kept, due to a line counting mismatch	0	0	0	0	0	0	0	0	0	0	1	0
Odd offsets are changing the C <sub>B</sub> -C <sub>R</sub> sequence in the output stream to C <sub>R</sub> -C <sub>B</sub> sequence	0	0	0	0	0	0	0	0	0	0	1	1
Maximum possible pixel offset = 4095	1	1	1	1	1	1	1	1	1	1	1	1

[1] Reference for counting are luminance samples.

Table 107: Horizontal input window length; register set A [96h[7:0]; 97h[3:0]] and B [C6h[7:0]; C7h[3:0]]

Horizontal input acquisition window definition input window length in X (horizontal) direction [1]	Control bits											
	A [97h[3:0]] and B [C7h[3:0]]				A [96h[7:0]] and B [C6h[7:0]]							
	XS11	XS10	XS9	XS8	XS7	XS6	XS5	XS4	XS3	XS2	XS1	XS0
No output	0	0	0	0	0	0	0	0	0	0	0	0
Odd lengths are allowed, but will be rounded up to even lengths	0	0	0	0	0	0	0	0	0	0	0	1
Maximum possible number of input pixels = 4095	1	1	1	1	1	1	1	1	1	1	1	1

[1] Reference for counting are luminance samples.

Table 108: Vertical input window start; register set A [98h[7:0]; 99h[3:0]] and B [C8h[7:0]; C9h[3:0]]

Vertical input acquisition window definition offset in Y (vertical) direction [1]	Control bits											
	A [99h[3:0]] and B [C9h[3:0]]				A [98h[7:0]] and B [C8h[7:0]]							
	YO11	YO10	YO9	YO8	YO7	YO6	YO5	YO4	YO3	YO2	YO1	YO0
Line offset = 0	0	0	0	0	0	0	0	0	0	0	0	0
Line offset = 1	0	0	0	0	0	0	0	0	0	0	0	1
Maximum line offset = 4095	1	1	1	1	1	1	1	1	1	1	1	1

[1] For trigger condition: STRC[1:0] 90h[1:0] = 00; YO + YS > (number of input lines per field - 2), will result in field dropping. Other trigger conditions: YO > (number of input lines per field - 2), will result in field dropping.

Table 109: Vertical input window length; register set A [9Ah[7:0]; 9Bh[3:0]] and B [CAh[7:0]; CBh[3:0]]

Vertical input acquisition window definition input window length in Y (vertical) direction [1]	Control bits											
	A [9Bh[3:0]] and B [CBh[3:0]]				A [9Ah[7:0]] and B [CAh[7:0]]							
	YS11	YS10	YS9	YS8	YS7	YS6	YS5	YS4	YS3	YS2	YS1	YS0
No input lines	0	0	0	0	0	0	0	0	0	0	0	0
1 input line	0	0	0	0	0	0	0	0	0	0	0	1
Maximum possible number of input lines = 4095	1	1	1	1	1	1	1	1	1	1	1	1

[1] For trigger condition: STRC[1:0] 90h[1:0] = 00; YO + YS > (number of input lines per field – 2), will result in field dropping. Other trigger conditions: YS > (number of input lines per field – 2), will result in field dropping.

### 10.5.8 Subaddresses 9Ch to 9Fh

**Table 110: Horizontal output window length; register set A [9Ch[7:0]; 9Dh[3:0]] and B [CCh[7:0]; CDh[3:0]]**

Horizontal output acquisition window definition number of desired output pixels in X (horizontal) direction [1]	Control bits											
	A [9Dh[3:0]] and B [CDh[3:0]]				A [9Ch[7:0]] and B [CCh[7:0]]							
	XD11	XD10	XD9	XD8	XD7	XD6	XD5	XD4	XD3	XD2	XD1	XD0
No output	0	0	0	0	0	0	0	0	0	0	0	0
Odd lengths are allowed, but will be filled up to even lengths	0	0	0	0	0	0	0	0	0	0	0	1
Maximum possible number of input pixels = 4095 [2]	1	1	1	1	1	1	1	1	1	1	1	1

[1] Reference for counting are luminance samples.

[2] If the desired output length is greater than the number of scaled output pixels, the last scaled pixel is repeated.

**Table 111: Vertical output window length; register set A [9Eh[7:0]; 9Fh[3:0]] and B [CEh[7:0]; CFh[3:0]]**

Vertical output acquisition window definition number of desired output lines in Y (vertical) direction	Control bits											
	A [9Fh[3:0]] and B [CFh[3:0]]				A [9Eh[7:0]] and B [CEh[7:0]]							
	YD11	YD10	YD9	YD8	YD7	YD6	YD5	YD4	YD3	YD2	YD1	YD0
No output	0	0	0	0	0	0	0	0	0	0	0	0
1 pixel	0	0	0	0	0	0	0	0	0	0	0	1
Maximum possible number of output lines = 4095 [1]	1	1	1	1	1	1	1	1	1	1	1	1

[1] If the desired output length is greater than the number of scaled output lines, the processing is cut.

### 10.5.9 Subaddresses A0h to A2h

**Table 112: Horizontal prescaling; register set A [A0h[5:0]] and B [D0h[5:0]]**

Horizontal integer prescaling ratio (XPSC)	Control bits D5 to D0					
	XPSC5	XPSC4	XPSC3	XPSC2	XPSC1	XPSC0
Not allowed	0	0	0	0	0	0
Downscale = 1	0	0	0	0	0	1
Downscale = $\frac{1}{2}$	0	0	0	0	1	0
...	...	...	...	...	...	...
Downscale = $\frac{1}{63}$	1	1	1	1	1	1

**Table 113: Accumulation length; register set A [A1h[5:0]] and B [D1h[5:0]]**

Horizontal prescaler accumulation sequence length (XACL)	Control bits D5 to D0					
	XACL5	XACL4	XACL3	XACL2	XACL1	XACL0
Accumulation length = 1	0	0	0	0	0	0
Accumulation length = 2	0	0	0	0	0	1
...	...	...	...	...	...	...
Accumulation length = 64	1	1	1	1	1	1

**Table 114: Prescaler DC gain and FIR prefilter control; register set A [A2h[7:4]] and B [D2h[7:4]]** <sup>[1]</sup>

FIR prefilter control	Control bits D7 to D4			
	PFUV1	PFUV0	PFY1	PFY0
Luminance FIR filter bypassed	X	X	0	0
$H_y(z) = \frac{1}{4} (1 \ 2 \ 1)$	X	X	0	1
$H_y(z) = \frac{1}{8} (-1 \ 1 \ 1.75 \ 4.5 \ 1.75 \ 1 \ -1)$	X	X	1	0
$H_y(z) = \frac{1}{8} (1 \ 2 \ 2 \ 2 \ 1)$	X	X	1	1
Chrominance FIR filter bypassed	0	0	X	X
$H_{uv}(z) = \frac{1}{4} (1 \ 2 \ 1)$	0	1	X	X
$H_{uv}(z) = \frac{1}{32} (3 \ 8 \ 10 \ 8 \ 3)$	1	0	X	X
$H_{uv}(z) = \frac{1}{8} (1 \ 2 \ 2 \ 2 \ 1)$	1	1	X	X

[1] X = don't care.

**Table 115: Prescaler DC gain and FIR prefilter control; register set A [A2h[3:0]] and B [D2h[3:0]]** <sup>[1]</sup>

Prescaler DC gain	Control bits D3 to D0			
	XC2_1	XDCG2	XDCG1	XDCG0
Prescaler output is renormalized by gain factor = 1	X	0	0	0
Prescaler output is renormalized by gain factor = $\frac{1}{2}$	X	0	0	1
Prescaler output is renormalized by gain factor = $\frac{1}{4}$	X	0	1	0
Prescaler output is renormalized by gain factor = $\frac{1}{8}$	X	0	1	1
Prescaler output is renormalized by gain factor = $\frac{1}{16}$	X	1	0	0
Prescaler output is renormalized by gain factor = $\frac{1}{32}$	X	1	0	1
Prescaler output is renormalized by gain factor = $\frac{1}{64}$	X	1	1	0
Prescaler output is renormalized by gain factor = $\frac{1}{128}$	X	1	1	1
Weighting of all accumulated samples is factor '1'; e.g. XACL = 4 $\Rightarrow$ sequence 1 + 1 + 1 + 1 + 1	0	X	X	X
Weighting of samples inside sequence is factor '2'; e.g. XACL = 4 $\Rightarrow$ sequence 1 + 2 + 2 + 2 + 1	1	X	X	X

[1] X = don't care.

## 10.5.10 Subaddresses A4h to A6h

Table 116: Luminance brightness control; register set A [A4h[7:0]] and B [D4h[7:0]]

Luminance brightness control	Control bits D7 to D0							
	BRIG7	BRIG6	BRIG5	BRIG4	BRIG3	BRIG2	BRIG1	BRIG0
Value = 0	0	0	0	0	0	0	0	0
Nominal value = 128	1	0	0	0	0	0	0	0
Value = 255	1	1	1	1	1	1	1	1

Table 117: Luminance contrast control; register set A [A5h[7:0]] and B [D5h[7:0]]

Luminance contrast control	Control bits D7 to D0							
	CONT7	CONT6	CONT5	CONT4	CONT3	CONT2	CONT1	CONT0
Gain = 0	0	0	0	0	0	0	0	0
Gain = $\frac{1}{64}$	0	0	0	0	0	0	0	1
Nominal gain = 64	0	1	0	0	0	0	0	0
Gain = $\frac{127}{64}$	0	1	1	1	1	1	1	1

Table 118: Chrominance saturation control; register set A [A6h[7:0]] and B [D6h[7:0]]

Chrominance saturation control	Control bits D7 to D0							
	SATN7	SATN6	SATN5	SATN4	SATN3	SATN2	SATN1	SATN0
Gain = 0	0	0	0	0	0	0	0	0
Gain = $\frac{1}{64}$	0	0	0	0	0	0	0	1
Nominal gain = 64	0	1	0	0	0	0	0	0
Gain = $\frac{127}{64}$	0	1	1	1	1	1	1	1

## 10.5.11 Subaddresses A8h to AEh

Table 119: Horizontal luminance scaling increment; register set A [A8h[7:0]; A9h[7:0]] and B [D8h[7:0]; D9h[7:0]]

Horizontal luminance scaling increment	Control bits			
	A [A9h[7:4]] B [D9h[7:4]]	A [A9h[3:0]] B [D9h[3:0]]	A [A8h[7:4]] B [D8h[7:4]]	A [A8h[3:0]] B [D8h[3:0]]
	XSCY[15:12] <sup>[1]</sup>	XSCY[11:8]	XSCY[7:4]	XSCY[3:0]
Scale = $1024\frac{1}{1}$ (theoretical) zoom	0000	0000	0000	0000
Scale = $1024\frac{1}{294}$ ; lower limit defined by data path structure	0000	0001	0010	0110
Scale = $1024\frac{1}{1023}$ zoom	0000	0011	1111	1111
Scale = 1; equals 1024	0000	0100	0000	0000
Scale = $1024\frac{1}{1025}$ downscale	0000	0100	0000	0001
Scale = $1024\frac{1}{8191}$ downscale	0001	1111	1111	1111

[1] Bits XSCY[15:13] are reserved and are set to logic 0.

Table 120: Horizontal luminance phase offset; register set A [AAh[7:0]] and B [DAh[7:0]]

Horizontal luminance phase offset	Control bits D7 to D0							
	XPHY7	XPHY6	XPHY5	XPHY4	XPHY3	XPHY2	XPHY1	XPHY0
Offset = 0	0	0	0	0	0	0	0	0
Offset = $\frac{1}{32}$ pixel	0	0	0	0	0	0	0	1
Offset = $\frac{32}{32} = 1$ pixel	0	0	1	0	0	0	0	0
Offset = $\frac{255}{32}$ pixel	1	1	1	1	1	1	1	1

Table 121: Horizontal chrominance scaling increment; register set A [ACh[7:0]; ADh[7:0]] and B [DCh[7:0]; DDh[7:0]]

Horizontal chrominance scaling increment	Control bits			
	A [ADh[7:4]] B [DDh[7:4]]	A [ADh[3:0]] B [DDh[3:0]]	A [ACh[7:4]] B [DCh[7:4]]	A [ACh[3:0]] B [DCh[3:0]]
	XSCC[15:12] <sup>[1]</sup>	XSCC[11:8]	XSCC[7:4]	XSCC[3:0]
This value must be set to the luminance value $\frac{1}{2}$ XSCY[15:0]	0000	0000	0000	0000
	0000	0000	0000	0001
	0001	1111	1111	1111

[1] Bits XSCC[15:13] are reserved and are set to logic 0.

Table 122: Horizontal chrominance phase offset; register set A [AEh[7:0]] and B [DEh[7:0]]

Horizontal chrominance phase offset	Control bits D7 to D0							
	XPHC7	XPHC6	XPHC5	XPHC4	XPHC3	XPHC2	XPHC1	XPHC0
This value must be set to $\frac{1}{2}$ XPHY[7:0]	0	0	0	0	0	0	0	0
	0	0	0	0	0	0	0	1
	1	1	1	1	1	1	1	1

### 10.5.12 Subaddresses B0h to BFh

Table 123: Vertical luminance scaling increment; register set A [B0h[7:0]; B1h[7:0]] and B [E0h[7:0]; E1h[7:0]]

Vertical luminance scaling increment	Control bits			
	A [B1h[7:4]] B [E1h[7:4]]	A [B1h[3:0]] B [E1h[3:0]]	A [B0h[7:4]] B [E0h[7:4]]	A [B0h[3:0]] B [E0h[3:0]]
	YSCY[15:12]	YSCY[11:8]	YSCY[7:4]	YSCY[3:0]
Scale = $\frac{1024}{1}$ (theoretical) zoom	0000	0000	0000	0001
Scale = $\frac{1024}{1023}$ zoom	0000	0011	1111	1111
Scale = 1, equals 1024	0000	0100	0000	0000
Scale = $\frac{1024}{1025}$ downscale	0000	0100	0000	0001
Scale = $\frac{1}{63.999}$ downscale	1111	1111	1111	1111

Table 124: Vertical chrominance scaling increment; register set A [B2h[7:0]; B3h[7:0]] and B [E2h[7:0]; E3h[7:0]]

Vertical chrominance scaling increment	Control bits			
	A [B3h[7:4]] B [E3h[7:4]]	A [B3h[3:0]] B [E3h[3:0]]	A [B2h[7:4]] B [E2h[7:4]]	A [B2h[3:0]] B [E2h[3:0]]
	YSCC[15:12]	YSCC[11:8]	YSCC[7:4]	YSCC[3:0]
This value must be set to the luminance value YSCY[15:0]	0000	0000	0000	0001
	1111	1111	1111	1111

Table 125: Vertical scaling mode control; register set A [B4h[4 and 0]] and B [E4h[4 and 0]] [1]

Vertical scaling mode control	Control bits D4 and D0	
	YMIR	YMODE
Vertical scaling performs linear interpolation between lines	X	0
Vertical scaling performs higher order accumulating interpolation, better alias suppression	X	1
No mirroring	0	X
Lines are mirrored	1	X

[1] X = don't care.

Table 126: Vertical chrominance phase offset '00'; register set A [B8h[7:0]] and B [E8h[7:0]]

Vertical chrominance phase offset	Control bits D7 to D0							
	YPC07	YPC06	YPC05	YPC04	YPC03	YPC02	YPC01	YPC00
Offset = 0	0	0	0	0	0	0	0	0
Offset = $\frac{32}{32} = 1$ line	0	0	1	0	0	0	0	0
Offset = $\frac{255}{32}$ lines	1	1	1	1	1	1	1	1

Table 127: Vertical luminance phase offset '00'; register set A [BCh[7:0]] and B [ECh[7:0]]

Vertical luminance phase offset	Control bits D7 to D0							
	YPY07	YPY06	YPY05	YPY04	YPY03	YPY02	YPY01	YPY00
Offset = 0	0	0	0	0	0	0	0	0
Offset = $\frac{32}{32} = 1$ line	0	0	1	0	0	0	0	0
Offset = $\frac{255}{32}$ lines	1	1	1	1	1	1	1	1

## 11. Programming start setup

### 11.1 Decoder part

The given values force the following behavior of the SAA7114 decoder part:

- The analog input AI11 expects an NTSC M, PAL B, D, G, H and I or SECAM signal in CVBS format; analog anti-alias filter and AGC active
- Automatic field detection enabled
- Standard ITU 656 output format enabled on expansion (X) port
- Contrast, brightness and saturation control in accordance with ITU standards
- Adaptive comb filter for luminance and chrominance activated
- Pins LLC, LLC2, XTOUT, RTS0, RTS1 and RTCO are set to 3-state

**Table 128: Decoder part start setup values for the three main standards**

Subaddress (hexadecimal)	Register function	Bit name <sup>[1]</sup>	Values (hexadecimal)		
			NTSC M	PAL B, D, G, H and I	SECAM
00	chip version	ID7 to ID4	read only		
01	increment delay	X, X, X, X, IDEL3 to IDEL0	08	08	08
02	analog input control 1	FUSE1, FUSE0, GUDL1, GUDL0 and MODE3 to MODE0	C0	C0	C0
03	analog input control 2	X, HLNRS, VBSL, WPOFF, HOLDG, GAFIX, GAI28 and GAI18	10	10	10
04	analog input control 3	GAI17 to GAI10	90	90	90
05	analog input control 4	GAI27 to GAI20	90	90	90
06	horizontal sync start	HSB7 to HSB0	EB	EB	EB
07	horizontal sync stop	HSS7 to HSS0	E0	E0	E0
08	sync control	AUFD, FSEL, FOET, HTC1, HTC0, HPLL, VNOI1 and VNOI0	98	98	98
09	luminance control	BYPS, YCOMB, LDEL, LUBW and LUF13 to LUF10	40	40	1B
0A	luminance brightness control	DBR17 to DBR10	80	80	80
0B	luminance contrast control	DCON7 to DCON0	44	44	44
0C	chrominance saturation control	DSAT7 to DSAT0	40	40	40
0D	chrominance hue control	HUEC7 to HUEC0	00	00	00
0E	chrominance control 1	CDTO, CSTD2 to CSTD0, DCVF, FCTC, X and CCOMB	89	81	D0
0F	chrominance gain control	ACGC and CGAIN6 to CGAIN0	2A	2A	80
10	chrominance control 2	OFFU1, OFFU0, OFFV1, OFFV0, CHBW and LCBW2 to LCBW0	0E	06	00
11	mode/delay control	COLO, RTP1, HDEL1, HDEL0, RTP0 and YDEL2 to YDEL0	00	00	00
12	RT signal control	RTSE13 to RTSE10 and RTSE03 to RTSE00	00	00	00
13	RT/X port output control	RTCE, XRHS, XRVS1, XRVS0, HLSEL and OFTS2 to OFTS0	00	00	00

Table 128: Decoder part start setup values for the three main standards ...continued

Subaddress (hexadecimal)	Register function	Bit name [1]	Values (hexadecimal)		
			NTSC M	PAL B, D, G, H and I	SECAM
14	analog/ADC/compatibility control	CM99, UPTCV, AOSL1, AOSL0, XTOUTE, OLDSB, APCK1 and APCK0	00	00	00
15	VGATE start, FID change	VSTA7 to VSTA0	11	11	11
16	VGATE stop	VSTO7 to VSTO0	FE	FE	FE
17	miscellaneous, VGATE configuration and MSBs	LLCE, LLC2E, X, X, X, VGPS, VSTO8 and VSTA8	40	40	40
18	raw data gain control	RAWG7 to RAWG0	40	40	40
19	raw data offset control	RAWO7 to RAWO0	80	80	80
1A to 1E	reserved	X, X, X, X, X, X, X, X	00	00	00
1F	status byte video decoder (OLDSB = 0)	INTL, HLVLN, FIDT, GLIMIT, GLIMB, WIPA, COPRO and RDCAP	read only		

[1] All X values must be set to logic 0.

## 11.2 Audio clock generation part

The given values force the following behavior of the SAA7114 audio clock generation part:

- Used crystal is 24.576 MHz
- Expected field frequency is 59.94 Hz (e.g. NTSC M standard)
- Generated audio master clock frequency at pin AMCLK is  $256 \times 44.1 \text{ kHz} = 11.2896 \text{ MHz}$
- AMCLK is externally connected to AMXCLK [short-cut between pins K12 (37) and J12 (41)]
- ASCLK =  $32 \times 44.1 \text{ kHz} = 1.4112 \text{ MHz}$
- ALRCLK is 44.1 kHz

Table 129: Audio clock part setup values

Subaddress (hexadecimal)	Register function	Bit name [1]	Values (binary)								Start (hexadecimal)
			7	6	5	4	3	2	1	0	
30	audio master clock cycles per field; bits D7 to D0	ACPF7 to ACPF0	1	0	1	1	1	1	0	0	BC
31	audio master clock cycles per field; bits D15 to D8	ACPF15 to ACPF8	1	1	0	1	1	1	1	1	DF
32	audio master clock cycles per field; bits D17 and D16	X, X, X, X, X, X, ACPF17 and ACPF16	0	0	0	0	0	0	1	0	02
33	reserved	X, X, X, X, X, X, X, X	0	0	0	0	0	0	0	0	00
34	audio master clock nominal increment; bits D7 to D0	ACNI7 to ACNI0	1	1	0	0	1	1	0	1	CD
35	audio master clock nominal increment; bits D15 to D8	ACNI15 to ACNI8	1	1	0	0	1	1	0	0	CC
36	audio master clock nominal increment; bits D21 to D16	X, X, ACNI21 to ACNI16	0	0	1	1	1	0	1	0	3A



Table 129: Audio clock part setup values ...continued

Subaddress (hexadecimal)	Register function	Bit name [1]	Values (binary)								Start (hexadecimal)
			7	6	5	4	3	2	1	0	
37	reserved	X, X, X, X, X, X, X, X	0	0	0	0	0	0	0	0	00
38	clock ratio AMXCLK to ASCLK	X, X, SDIV5 to SDIV0	0	0	0	0	0	0	1	1	03
39	clock ratio ASCLK to ALRCLK	X, X, LRDIV5 to LRDIV0	0	0	0	1	0	0	0	0	10
3A	audio clock generator basic setup	X, X, X, X, APLL, AMVR, LRP, SCPH	0	0	0	0	0	0	0	0	00
3B to 3F	reserved	X, X, X, X, X, X, X, X	0	0	0	0	0	0	0	0	00

[1] All X values must be set to logic 0.

### 11.3 Data slicer and data type control part

The given values force the following behavior of the SAA7114 VBI data slicer part:

- Closed captioning data are expected at line 21 of field 1 (60 Hz/525 line system)
- All other lines are processed as active video
- Sliced data are framed by ITU 656 like SAV/EAV sequence (DID[5:0] = 3Eh ⇒ MSB of SAV/EAV = 1)

Table 130: Data slicer start setup values

Subaddress (hexadecimal)	Register function	Bit name [1]	Values (binary)								Start (hexadecimal)
			7	6	5	4	3	2	1	0	
40	slicer control 1	X, HAM_N, FCE, HUNT_N, X, X, X, X	0	1	0	0	0	0	0	0	40
41 to 53	line control register 2 to 20	LCRn_7 to LCRn_0 (n = 2 to 20)	1	1	1	1	1	1	1	1	FF
54	line control register 21	LCR21_7 to LCR21_0	0	1	0	1	1	1	1	1	5F
55 to 57	line control register 22 to 24	LCRn_7 to LCRn_0 (n = 22 to 24)	1	1	1	1	1	1	1	1	FF
58	programmable framing code	FC7 to FC0	0	0	0	0	0	0	0	0	00
59	horizontal offset for slicer	HOFF7 to HOFF0	0	1	0	0	0	1	1	1	47
5A	vertical offset for slicer	VOFF7 to VOFF0	0	0	0	0	0	1	1	0	06 [2]
5B	field offset and MSBs for horizontal and vertical offset	FOFF, RECODE, X, VOFF8, X, HOFF10 to HOFF8	1	0	0	0	0	0	1	1	83 [2]
5C	reserved	X, X, X, X, X, X, X, X	0	0	0	0	0	0	0	0	00
5D	header and data identification code control	FVREF, X, DID5 to DID0	0	0	1	1	1	1	1	0	3E
5E	sliced data identification code	X, X, SDID5 to SDID0	0	0	0	0	0	0	0	0	00
5F	reserved	X, X, X, X, X, X, X, X	0	0	0	0	0	0	0	0	00
60	slicer status byte 0	-, FC8V, FC7V, VPSV, PPV, CCV, -, -	read only register								
61	slicer status byte 1	-, -, F21_N, LN8 to LN4	read only register								
62	slicer status byte 2	LN3 to LN0, DT3 to DT0	read only register								

[1] All X values must be set to logic 0.

[2] Changes for 50 Hz/625 line systems: subaddress 5Ah = 03h and subaddress 5Bh = 03h.

## 11.4 Scaler and interfaces

[Table 131](#) shows some examples for the scaler programming with:

- prsc = prescale ratio
- fisc = fine scale ratio
- vsc = vertical scale ratio

The ratio is defined as:  $\frac{\text{number of input pixel}}{\text{number of output pixel}}$

In the following settings the VBI data slicer is inactive. To activate the VBI data slicer, VITX[1:0] 86h[7:6] has to be set to '11'. Depending on the VBI data slicer settings, the sliced VBI data is inserted after the end of the scaled video lines, if the regions of VBI data slicer and scaler overlaps.

To compensate the running-in of the vertical scaler, the vertical input window lengths are extended by 2 lines to 290 lines, respectively 242 lines for XS, but the scaler increment calculations are done with 288 lines, respectively 240 lines.

### 11.4.1 Trigger condition

For trigger condition STRC[1:0] 90h[1:0] not equal to '00'.

If the value of (YO + YS) is greater than or equal to 262 (NTSC), respectively 312 (PAL) the output field rate is reduced to 30 Hz, respectively 25 Hz.

Horizontal and vertical offsets (XO and YO) have to be used to adjust the displayed video in the display window. As this adjustment is application dependent, the listed values are only dummy values.

### 11.4.2 Maximum zoom factor

The maximum zoom factor is dependent on the back-end data rate and therefore back-end clock and data format dependent (8-bit or 16-bit output). The maximum horizontal zoom is limited to approximately 3.5, due to internal data path restrictions.

## 11.4.3 Examples

Table 131: Example of configurations

Example number	Scaler source and reference events	Input window	Output window	Scale ratios
1	analog input to 8-bit I port output, with SAV/EAV codes, 8-bit serial byte stream decoder output at X port; acquisition trigger at falling edge vertical and rising edge horizontal reference signal; H and V gates on IGPH and IGPV, IGP0 = VBI sliced data flag, IGP1 = FIFO almost full, level $\geq 24$ , IDQ qualifier logic 1 active	720 × 240	720 × 240	prsc = 1; fisc = 1; vsc = 1
2	analog input to 16-bit output, without SAV/EAV codes, Y on I port, C <sub>B-CR</sub> on H port and decoder output at X port; acquisition trigger at falling edge vertical and rising edge horizontal reference signal; H and V-pulses on IGPH and IGPV, output FID on IGP0, IGP1 fixed to logic 1, IDQ qualifier logic 0 active	704 × 288	768 × 288	prsc = 1; fisc = 0.91667; vsc = 1
3	X port input 8-bit with SAV/EAV codes, no reference signals on XRH and XRV, XCLK as gated clock; field detection and acquisition trigger on different events; acquisition triggers at rising edge vertical and rising edge horizontal; I port output 8-bit with SAV/EAV codes like example number 1	720 × 240	352 × 288	prsc = 2; fisc = 1.022; vsc = 0.8333
4	X port and H port for 16-bit Y-C <sub>B-CR</sub> 4 : 2 : 2 input (if no 16-bit output selected); XRH and XRV as references; field detection and acquisition trigger at falling edge vertical and rising edge horizontal; I port output 8-bit with SAV/EAV codes, but Y only output	720 × 288	200 × 80	prsc = 2; fisc = 1.8; vsc = 3.6

Table 132: Scaler and interface configuration example

I <sup>2</sup> C-bus address (hex)	Main functionality	Example 1		Example 2		Example 3		Example 4		
		Hex	Dec	Hex	Dec	Hex	Dec	Hex	Dec	
<b>Global settings</b>										
80	task enable, IDQ and back-end clock definition	10	-	10	-	10	-	10	-	
83	XCLK output phase and X port output enable	01	-	01	-	00	-	00	-	
84	IGPH, IGPV, IGP0 and IGP1 output definition	A0	-	C5	-	A0	-	A0	-	
85	signal polarity control and I port byte swapping	10	-	09	-	10	-	10	-	
86	FIFO flag thresholds and video/text arbitration	45	-	40	-	45	-	45	-	
87	ICLK and IDQ output phase and I port enable	01	-	01	-	01	-	01	-	

Table 132: Scaler and interface configuration example ...continued

I <sup>2</sup> C-bus address (hex)	Main functionality	Example 1		Example 2		Example 3		Example 4	
		Hex	Dec	Hex	Dec	Hex	Dec	Hex	Dec
88	power save control and software reset	F0	-	F0	-	F0	-	F0	-
<b>Task A: scaler input configuration and output format settings</b>									
90	task handling	00	-	00	-	00	-	00	-
91	scaler input source and format definition	08	-	08	-	18	-	38	-
92	reference signal definition at scaler input	10	-	10	-	10	-	10	-
93	I port output formats and configuration	80	-	40	-	80	-	84	-
<b>Input and output window definition</b>									
94	horizontal input offset (XO)	10	16	10	16	10	16	10	16
95		00	-	00	-	00	-	00	-
96	horizontal input (source) window length (XS)	D0	720	C0	704	D0	720	D0	720
97		02	-	02	-	02	-	02	-
98	vertical input offset (YO)	0A	10	0A	10	0A	10	0A	10
99		00	-	00	-	00	-	00	-
9A	vertical input (source) window length (YS)	F2	242	22	290	F2	242	22	290
9B		00	-	01	-	00	-	01	-
9C	horizontal output (destination) window length (XD)	D0	720	00	768	60	352	C8	200
9D		02	-	03	-	01	-	00	-
9E	vertical output (destination) window length (YD)	F0	240	20	288	20	288	50	80
9F		00	-	01	-	01	-	00	-
<b>Prefiltering and prescaling</b>									
A0	integer prescale (value '00' not allowed)	01	-	01	-	02	-	02	-
A1	accumulation length for prescaler	00	-	00	-	02	-	03	-
A2	FIR prefilter and prescaler DC normalization	00	-	00	-	AA	-	F2	-
A4	scaler brightness control	80	128	80	128	80	128	80	128
A5	scaler contrast control	40	64	40	64	40	64	11	17
A6	scaler saturation control	40	64	40	64	40	64	11	17
<b>Horizontal phase scaling</b>									
A8	horizontal scaling increment for luminance	00	1024	AA	938	18	1048	34	1844
A9		04	-	03	-	04	-	07	-
AA	horizontal phase offset luminance	00	-	00	-	00	-	00	-
AC	horizontal scaling increment for chrominance	00	512	D5	469	0C	524	9A	922
AD		02	-	01	-	02	-	03	-
AE	horizontal phase offset chrominance	00	-	00	-	00	-	00	-

Table 132: Scaler and interface configuration example ...continued

I <sup>2</sup> C-bus address (hex)	Main functionality	Example 1		Example 2		Example 3		Example 4	
		Hex	Dec	Hex	Dec	Hex	Dec	Hex	Dec
<b>Vertical scaling</b>									
B0	vertical scaling increment for luminance	00	1024	00	1024	55	853	66	3686
B1		04	-	04	-	03	-	0E	-
B2	vertical scaling increment for chrominance	00	1024	00	1024	55	853	66	3686
B3		04	-	04	-	03	-	0E	-
B4	vertical scaling mode control	00	-	00	-	00	-	01	-
B8 to BF	vertical phase offsets luminance and chrominance (need to be used for interlace correct scaled output)	start with B8 to BF at 00h, if there are no problems with the interlaced scaled output optimize according to <a href="#">Section 8.3.3.2</a>							

## 12. Limiting values

**Table 133: Limiting values**

In accordance with the Absolute Maximum Rating System (IEC 60134). All ground pins connected together and grounded (0 V); all supply pins connected together.

Symbol	Parameter	Conditions	Min	Max	Unit
V <sub>DDD</sub>	digital supply voltage		-0.5	+4.6	V
V <sub>DDA</sub>	analog supply voltage		-0.5	+4.6	V
V <sub>i(A)</sub>	input voltage at analog inputs		-0.5	+4.6	V
V <sub>i(n)</sub>	input voltage at pins XTALI, SDA and SCL		-0.5	V <sub>DDD</sub> + 0.5	V
V <sub>i(D)</sub>	input voltage at digital inputs or I/O pins	outputs in 3-state	-0.5	+4.6	V
		outputs in 3-state	[1] -0.5	+5.5	V
ΔV <sub>SS</sub>	voltage difference between V <sub>SSA(n)</sub> and V <sub>SSD(n)</sub>		-	100	mV
T <sub>stg</sub>	storage temperature		-65	+150	°C
T <sub>amb</sub>	ambient temperature		0	70	°C
V <sub>esd</sub>	electrostatic discharge voltage	human body model	[2] -	±2000	V
		machine model	[3] -	±150	V

[1] Condition for maximum voltage at digital inputs or I/O pins: 3.0 V < V<sub>DDD</sub> < 3.6 V.

[2] Class 2 according to JESD22-A114-B.

[3] Class A according to EIA/JESD22-A115-A.

## 13. Thermal characteristics

**Table 134: Thermal characteristics**

Symbol	Parameter	Conditions	Value	Unit
R <sub>th(j-a)</sub>	thermal resistance from junction to ambient			
	SAA7114E	in free air	[1] 38	K/W
	SAA7114H	in free air	[1] 38	K/W

[1] The overall R<sub>th(j-a)</sub> value can vary depending on the board layout. To minimize the effective R<sub>th(j-a)</sub> all power and ground pins must be connected to the power and ground layers directly. An ample copper area directly under the SAA7114 with a number of through-hole plating, connected to the ground layer (four-layer board: second layer), can also reduce the effective R<sub>th(j-a)</sub>. Please do not use any solder-stop varnish under the chip. In addition the usage of soldering glue with a high thermal conductance after curing is recommended.

## 14. Characteristics

**Table 135: Characteristics**

$V_{DD} = 3.0\text{ V to }3.6\text{ V}$ ;  $V_{DDA} = 3.1\text{ V to }3.5\text{ V}$ ;  $T_{amb} = 0\text{ }^{\circ}\text{C to }70\text{ }^{\circ}\text{C}$  (typical values excluded); timings and levels refer to drawings and conditions illustrated in [Figure 52](#); unless otherwise specified.

Symbol	Parameter	Conditions	Min	Typ	Max	Unit
<b>Supplies</b>						
$V_{DD}$	digital supply voltage		3.0	3.3	3.6	V
$I_{DD}$	digital supply current	X port 3-state; 8-bit I port	-	90	-	mA
$P_D$	power dissipation digital part		-	300	-	mW
$V_{DDA}$	analog supply voltage		3.1	3.3	3.5	V
$I_{DDA}$	analog supply current	AOSL1 and AOSL0 = 0				
		CVBS mode	-	47	-	mA
		Y/C mode	-	72	-	mA
$P_A$	power dissipation analog part	CVBS mode	-	150	-	mW
		Y/C mode	-	240	-	mW
$P_{\text{tot(A+D)}}$	total power dissipation analog and digital part	CVBS mode	[1]	450	-	mW
		Y/C mode	[1]	540	-	mW
$P_{\text{tot(A+D)(pd)}}$	total power dissipation analog and digital part in Power-down mode	CE pulled down to ground	-	5	-	mW
$P_{\text{tot(A+D)(ps)}}$	total power dissipation analog and digital part in Power-save mode	I <sup>2</sup> C-bus controlled via subaddress 88h = 0Fh	-	75	-	mW
<b>Analog part</b>						
$I_{\text{clamp}}$	clamping current	$V_I = 0.9\text{ V DC}$	-	$\pm 8$	-	$\mu\text{A}$
$V_{i(p-p)}$	input voltage (peak-to-peak value)	for normal video levels 1 V (p-p), -3 dB termination 27/47 $\Omega$ and AC coupling required; coupling capacitor = 22 nF	-	0.7	-	V
$ Z_i $	input impedance	clamping current off	200	-	-	k $\Omega$
$C_i$	input capacitance		-	-	10	pF
$\alpha_{cs}$	channel crosstalk	$f_i < 5\text{ MHz}$	-	-	-50	dB
<b>9-bit analog-to-digital converters</b>						
B	analog bandwidth	at -3 dB	-	7	-	MHz
$\phi_{\text{diff}}$	differential phase	amplifier plus anti-alias filter bypassed	-	2	-	deg
$G_{\text{diff}}$	differential gain	amplifier plus anti-alias filter bypassed	-	2	-	%
$f_{\text{clk(ADC)}}$	ADC clock frequency		12.8	-	14.3	MHz
$LE_{\text{dc(d)}}$	DC differential linearity error		-	0.7	-	LSB
$LE_{\text{dc(i)}}$	DC integral linearity error		-	1	-	LSB

**Table 135: Characteristics ...continued**

$V_{DD} = 3.0\text{ V to }3.6\text{ V}$ ;  $V_{DDA} = 3.1\text{ V to }3.5\text{ V}$ ;  $T_{amb} = 0\text{ }^{\circ}\text{C to }70\text{ }^{\circ}\text{C}$  (typical values excluded); timings and levels refer to drawings and conditions illustrated in [Figure 52](#); unless otherwise specified.

Symbol	Parameter	Conditions	Min	Typ	Max	Unit
<b>Digital inputs</b>						
$V_{IL(SCL,SDA)}$	LOW-level input voltage pins SDA and SCL		-0.5	-	+0.3 $V_{DD}$	V
$V_{IH(SCL,SDA)}$	HIGH-level input voltage pins SDA and SCL		0.7 $V_{DD}$	-	$V_{DD} + 0.5$	V
$V_{IL(XTALI)}$	LOW-level CMOS input voltage pin XTALI		-0.3	-	+0.8	V
$V_{IH(XTALI)}$	HIGH-level CMOS input voltage pin XTALI		2.0	-	$V_{DD} + 0.3$	V
$V_{IL(n)}$	LOW-level input voltage all other inputs		-0.3	-	+0.8	V
$V_{IH(n)}$	HIGH-level input voltage all other inputs		2.0	-	5.5	V
$I_{LI}$	input leakage current		-	-	1	$\mu\text{A}$
$I_{LI/O}$	I/O leakage current		-	-	10	$\mu\text{A}$
$C_i$	input capacitance	I/O at high-impedance	-	-	8	pF
<b>Digital outputs <a href="#">[2]</a></b>						
$V_{OL(SDA)}$	LOW-level output voltage pin SDA	SDA at 3 mA sink current	-	-	0.4	V
$V_{OL(ck)}$	LOW-level output voltage for clocks		0	-	0.6	V
$V_{OH(ck)}$	HIGH-level output voltage for clocks		2.4	-	$V_{DD} + 0.5$	V
$V_{OL(n)}$	LOW-level output voltage all other digital outputs		0	-	0.4	V
$V_{OH(n)}$	HIGH-level output voltage all other digital outputs		2.4	-	$V_{DD} + 0.5$	V
<b>Clock output timing (LLC and LLC2) <a href="#">[3]</a></b>						
$C_L$	output load capacitance		15	-	50	pF
$T_{cy}$	cycle time	pin LLC	35	-	39	ns
		pin LLC2	70	-	78	ns
$\delta$	duty factors for $t_{LLCH}/t_{LLC}$ and $t_{LLC2H}/t_{LLC2}$	$C_L = 40\text{ pF}$	40	-	60	%
$t_r$	rise time LLC and LLC2	0.2 V to $V_{DD} - 0.2\text{ V}$	-	-	5	ns
$t_f$	fall time LLC and LLC2	$V_{DD} - 0.2\text{ V to }0.2\text{ V}$	-	-	5	ns
$t_{d(LLC-LLC2)}$	delay time between LLC and LLC2 output	measured at 1.5 V; $C_L = 25\text{ pF}$	-4	-	+8	ns
<b>Horizontal PLL</b>						
$f_{hor(nom)}$	nominal line frequency	50 Hz field	-	15625	-	Hz
		60 Hz field	-	15734	-	Hz
$\Delta f_{hor}/f_{hor(nom)}$	permissible static deviation		-	-	5.7	%



**Table 135: Characteristics ...continued**

$V_{DD} = 3.0\text{ V to }3.6\text{ V}$ ;  $V_{DDA} = 3.1\text{ V to }3.5\text{ V}$ ;  $T_{amb} = 0\text{ }^{\circ}\text{C to }70\text{ }^{\circ}\text{C}$  (typical values excluded); timings and levels refer to drawings and conditions illustrated in [Figure 52](#); unless otherwise specified.

Symbol	Parameter	Conditions	Min	Typ	Max	Unit
<b>Subcarrier PLL</b>						
$f_{sc(nom)}$	nominal subcarrier frequency	PAL BGHI	-	4433619	-	Hz
		NTSC M	-	3579545	-	Hz
		PAL M	-	3575612	-	Hz
		PAL N	-	3582056	-	Hz
$\Delta f_{sc}$	lock-in range		$\pm 400$	-	-	Hz
<b>Crystal oscillator for 32.11 MHz [4]</b>						
$f_{xtal(nom)}$	nominal frequency		-	32.11	-	MHz
$\Delta f_{xtal(nom)}$	permissible nominal frequency deviation		-	-	$\pm 70 \times 10^{-6}$	
$\Delta f_{xtal(nom)(T)}$	permissible nominal frequency deviation with temperature		-	-	$\pm 30 \times 10^{-6}$	
<b>Crystal specification (X1)</b>						
$T_{amb(X1)}$	ambient temperature		0	-	70	$^{\circ}\text{C}$
$C_L$	load capacitance		8	-	-	pF
$R_s$	series resonance resistor		-	40	80	$\Omega$
$C_1$	motional capacitance		-	$1.5 \pm 20\%$	-	fF
$C_0$	parallel capacitance		-	$4.3 \pm 20\%$	-	pF
<b>Crystal oscillator for 24.576 MHz [4]</b>						
$f_{xtal(nom)}$	nominal frequency		-	24.576	-	MHz
$\Delta f_{xtal(nom)}$	permissible nominal frequency deviation		-	-	$\pm 50 \times 10^{-6}$	
$\Delta f_{xtal(nom)(T)}$	permissible nominal frequency deviation with temperature		-	-	$\pm 20 \times 10^{-6}$	
<b>Crystal specification (X1)</b>						
$T_{amb(X1)}$	ambient temperature		0	-	70	$^{\circ}\text{C}$
$C_L$	load capacitance		8	-	-	pF
$R_s$	series resonance resistor		-	40	80	$\Omega$
$C_1$	motional capacitance		-	$1.5 \pm 20\%$	-	fF
$C_0$	parallel capacitance		-	$3.5 \pm 20\%$	-	pF
<b>Clock input timing (XCLK)</b>						
$T_{cy}$	cycle time		31	-	45	ns
$\delta$	duty factors for $t_{LLCH}/t_{LLC}$		40	50	60	%
$t_r$	rise time		-	-	5	ns
$t_f$	fall time		-	-	5	ns
<b>Data and control signal input timing X port, related to XCLK input</b>						
$t_{SU;DAT}$	input data setup time		-	10	-	ns
$t_{HD;DAT}$	input data hold time		-	3	-	ns

**Table 135: Characteristics ...continued**

$V_{DD} = 3.0\text{ V to }3.6\text{ V}$ ;  $V_{DDA} = 3.1\text{ V to }3.5\text{ V}$ ;  $T_{amb} = 0\text{ }^{\circ}\text{C to }70\text{ }^{\circ}\text{C}$  (typical values excluded); timings and levels refer to drawings and conditions illustrated in [Figure 52](#); unless otherwise specified.

Symbol	Parameter	Conditions	Min	Typ	Max	Unit
<b>Clock output timing</b>						
$C_L$	output load capacitance		15	-	50	pF
$T_{cy}$	cycle time		35	-	39	ns
$\delta$	duty factor for $t_{XCLKH}/t_{XCLKL}$		35	-	65	%
$t_r$	rise time	0.6 V to 2.6 V	-	-	5	ns
$t_f$	fall time	2.6 V to 0.6 V	-	-	5	ns
<b>Data and control signal output timing X port, related to XCLK output (for <math>XPCK[1:0]83h[5:4] = 00</math> is default) [3]</b>						
$C_L$	output load capacitance		15	-	50	pF
$t_{OHD;DAT}$	output data hold time	$C_L = 15\text{ pF}$	-	14	-	ns
$t_{PD}$	propagation delay from positive edge of XCLK output	$C_L = 15\text{ pF}$	-	24	-	ns
<b>Control signal output timing RT port, related to LLC output</b>						
$C_L$	output load capacitance		15	-	50	pF
$t_{OHD;DAT}$	output hold time	$C_L = 15\text{ pF}$	-	14	-	ns
$t_{PD}$	propagation delay from positive edge of LLC output	$C_L = 15\text{ pF}$	-	24	-	ns
<b>ICLK output timing</b>						
$C_L$	output load capacitance		15	-	50	pF
$T_{cy}$	cycle time		31	-	45	ns
$\delta$	duty factor for $t_{ICLKH}/t_{ICLKL}$		35	-	65	%
$t_r$	rise time	0.6 V to 2.6 V	-	-	5	ns
$t_f$	fall time	2.6 V to 0.6 V	-	-	5	ns
<b>Data and control signal output timing I port, related to ICLK output (for <math>IPCK[1:0]87h[5:4] = 00</math> is default)</b>						
$C_L$	output load capacitance at all outputs		15	-	50	pF
$t_{OHD;DAT}$	output data hold time	$C_L = 15\text{ pF}$	-	12	-	ns
$t_{o(d)}$	output delay time	$C_L = 15\text{ pF}$	-	22	-	ns
<b>ICLK input timing</b>						
$T_{cy}$	cycle time		31	-	100	ns

[1] 8-bit image port output mode, expansion port is 3-stated.

[2] The levels must be measured with load circuits;  $1.2\text{ k}\Omega$  at 3 V (TTL load);  $C_L = 50\text{ pF}$ .

[3] The effects of rise and fall times are included in the calculation of  $t_{OHD;DAT}$  and  $t_{PD}$ . Timings and levels refer to drawings and conditions illustrated in [Figure 52](#).

[4] The crystal oscillator drive level is typically 0.28 mW.

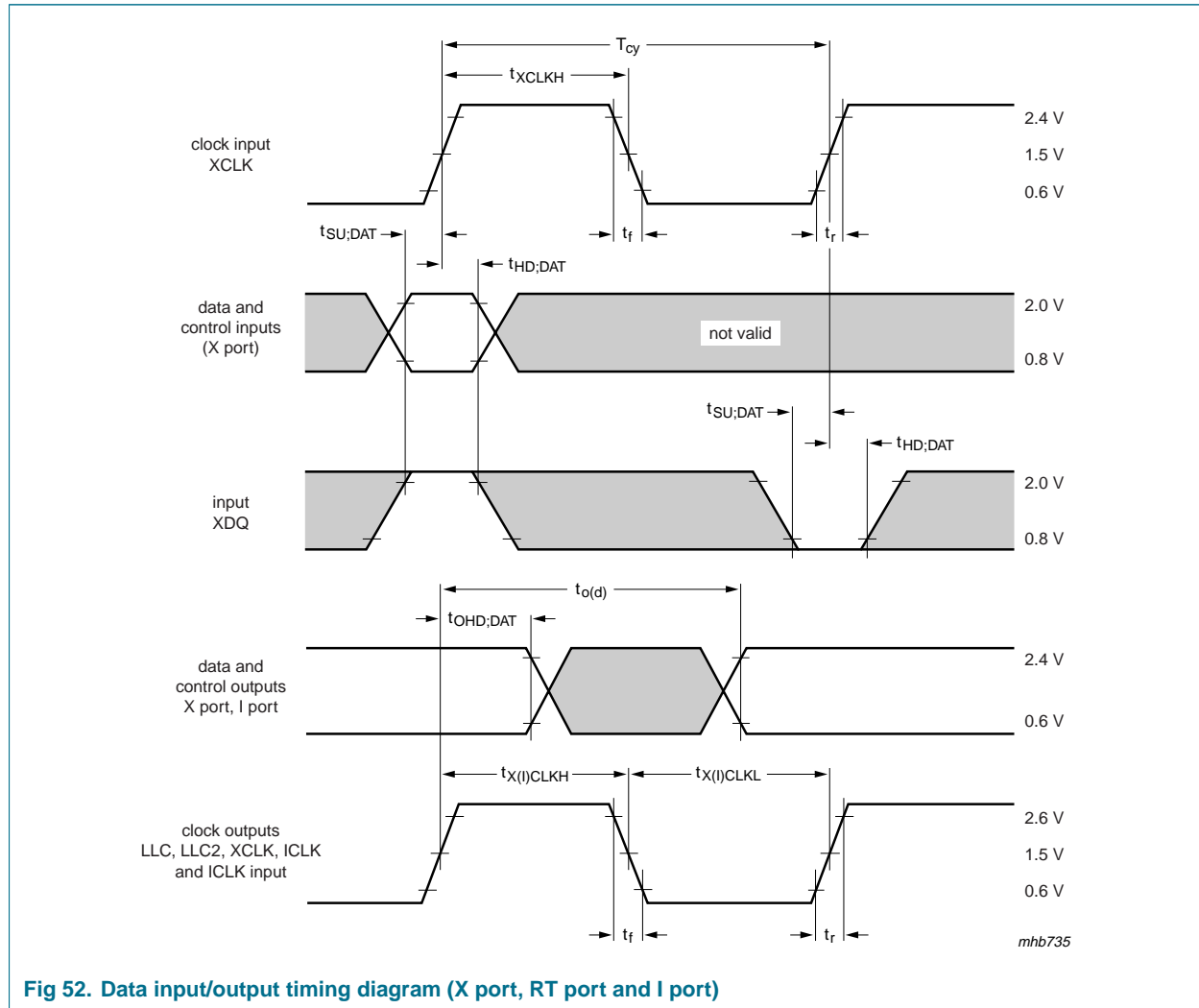

Fig 52. Data input/output timing diagram (X port, RT port and I port)

15. Application information

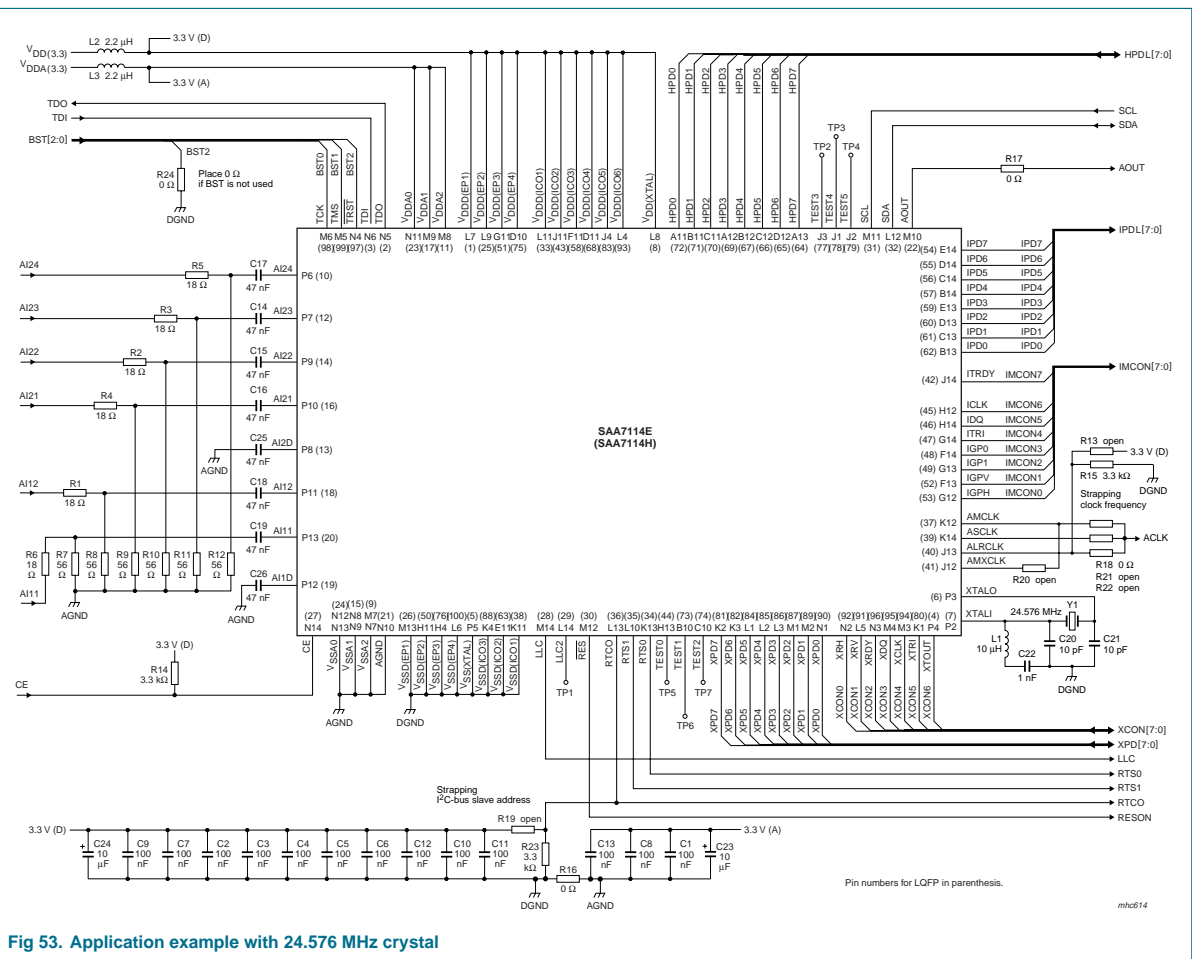

Fig 53. Application example with 24.576 MHz crystal

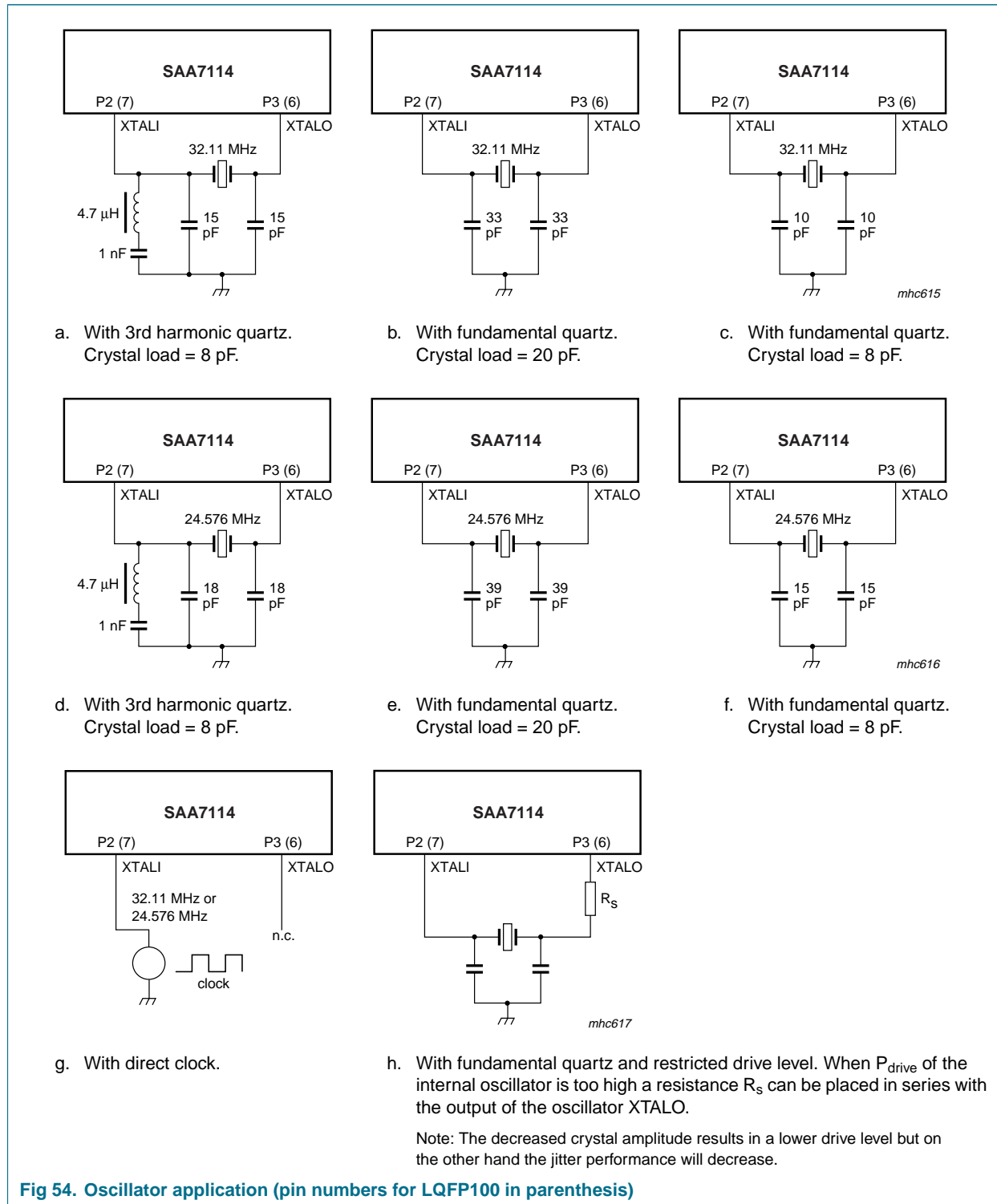

Fig 54. Oscillator application (pin numbers for LQFP100 in parenthesis)

## 16. Test information

### 16.1 Boundary scan test

The SAA7114 has built-in logic and 5 dedicated pins to support boundary scan testing which allows board testing without special hardware (nails). The SAA7114 follows the "IEEE Std. 1149.1 - Standard Test Access Port and Boundary-Scan Architecture" set by the Joint Test Action Group (JTAG) chaired by Philips.

The 5 special pins are Test Mode Select (TMS), Test Clock (TCK), Test Reset ( $\overline{\text{TRST}}$ ), Test Data Input (TDI) and Test Data Output (TDO).

The Boundary Scan Test (BST) functions BYPASS, EXTEST, SAMPLE, CLAMP and IDCODE are all supported; see [Table 136](#). Details about the JTAG BST-TEST can be found in specification "IEEE Std. 1149.1". A file containing the detailed Boundary Scan Description Language (BSDL) description of the SAA7114 is available on request.

**Table 136: BST instructions supported by the SAA7114**

Instruction	Description
BYPASS	This mandatory instruction provides a minimum length serial path (1 bit) between TDI and TDO when no test operation of the component is required.
EXTEST	This mandatory instruction allows testing of off-chip circuitry and board level interconnections.
SAMPLE	This mandatory instruction can be used to take a sample of the inputs during normal operation of the component. It can also be used to preload data values into the latched outputs of the boundary scan register.
CLAMP	This optional instruction is useful for testing when not all ICs have BST. This instruction addresses the bypass register while the boundary scan register is in external test mode.
IDCODE	This optional instruction will provide information on the components manufacturer, part number and version number.

#### 16.1.1 Initialization of boundary scan circuit

The Test Access Port (TAP) controller of an IC should be in the reset state (TEST\_LOGIC\_RESET) when the IC is in functional mode. This reset state also forces the instruction register into a functional instruction such as IDCODE or BYPASS.

To solve the power-up reset, the standard specifies that the TAP controller will be forced asynchronously to the TEST\_LOGIC\_RESET state by setting the  $\overline{\text{TRST}}$  pin LOW.

#### 16.1.2 Device identification codes

A device identification register is specified in "IEEE Std. 1149.1b-1994". It is a 32-bit register which contains fields for the specification of the IC manufacturer, the IC part number and the IC version number. Its biggest advantage is the possibility to check for the correct ICs mounted after production and determination of the version number of ICs during field service.

When the IDCODE instruction is loaded into the BST instruction register, the identification register will be connected between pins TDI and TDO of the IC. The identification register will load a component specific code during the CAPTURE\_DATA\_REGISTER state of the TAP controller and this code can subsequently be shifted out. At board level this code can be used to verify component manufacturer, type and version number. The device identification register contains 32 bits, numbered 31 to 0, where bit D31 is the most significant bit (nearest to TDI) and bit D0 is the least significant bit (nearest to TDO); see [Figure 55](#).

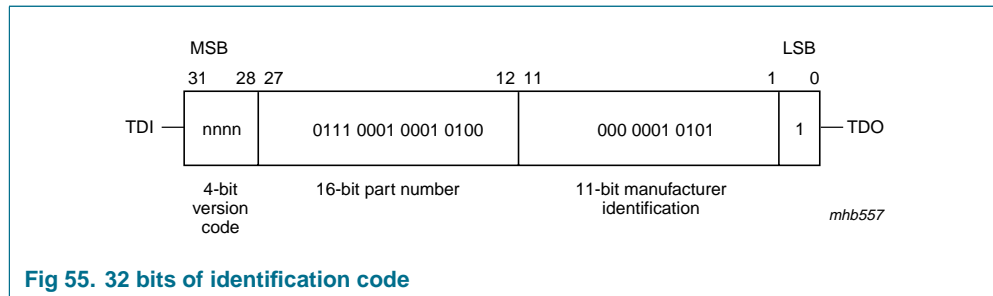

17. Package outline

LBGA156: plastic low profile ball grid array package; 156 balls; body 15 x 15 x 1.05 mm

SOT700-1

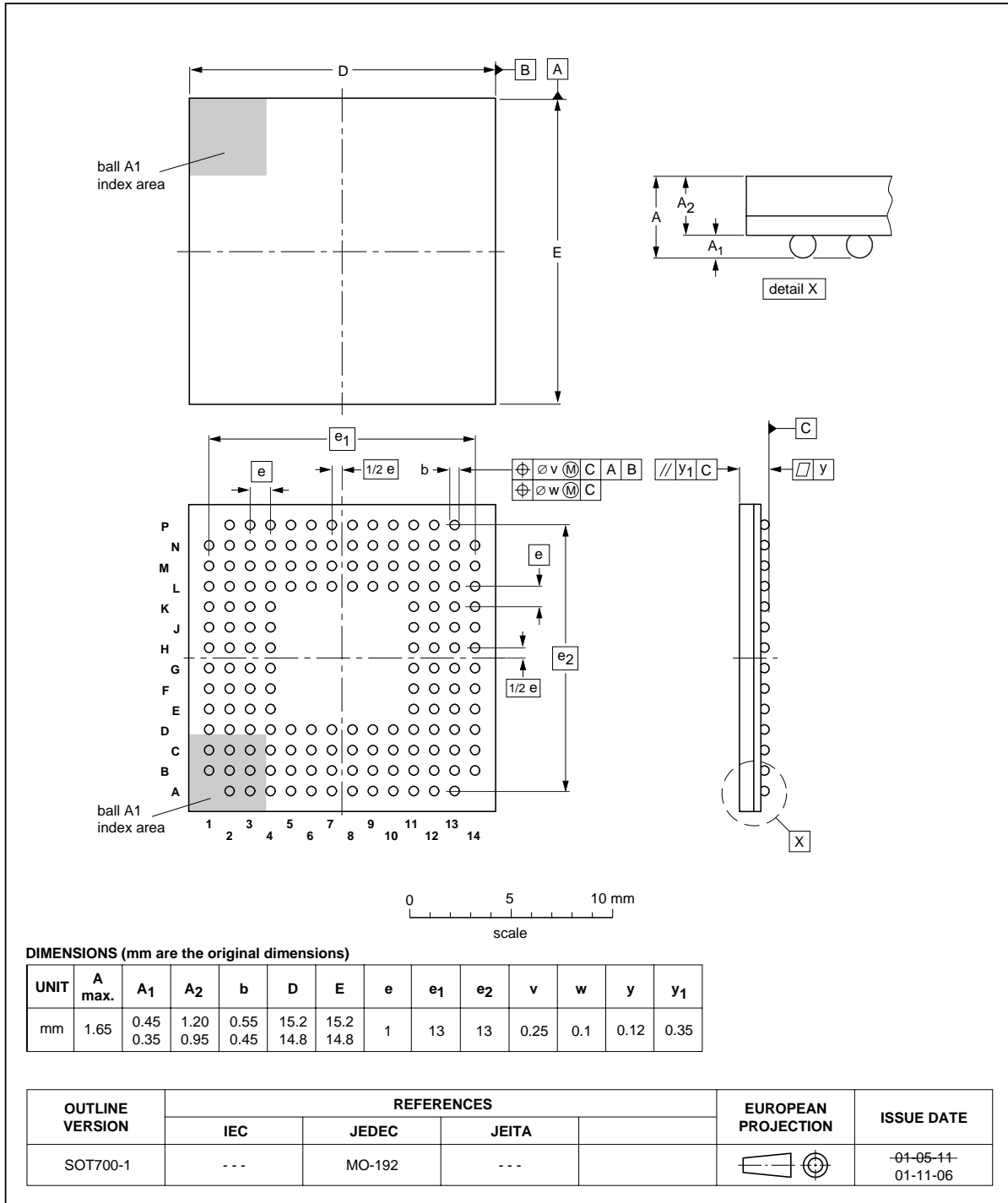

Fig 56. Package outline SOT700-1 (LBGA156)



LQFP100: plastic low profile quad flat package; 100 leads; body 14 x 14 x 1.4 mm

SOT407-1

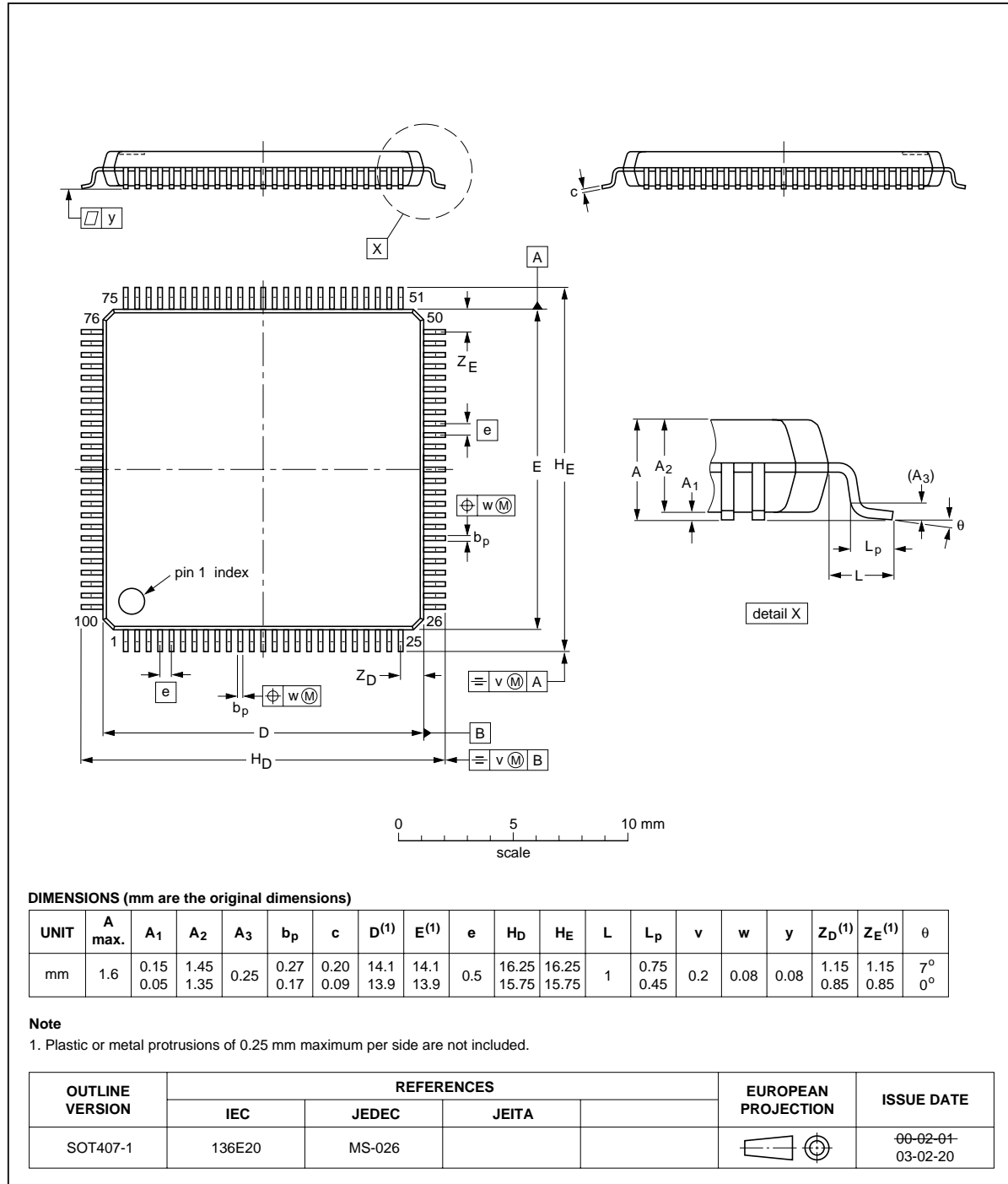

Fig 57. Package outline SOT407-1 (LQFP100)

## 18. Soldering

### 18.1 Introduction to soldering surface mount packages

This text gives a very brief insight to a complex technology. A more in-depth account of soldering ICs can be found in our *Data Handbook IC26; Integrated Circuit Packages* (document order number 9398 652 90011).

There is no soldering method that is ideal for all surface mount IC packages. Wave soldering can still be used for certain surface mount ICs, but it is not suitable for fine pitch SMDs. In these situations reflow soldering is recommended.

### 18.2 Reflow soldering

Reflow soldering requires solder paste (a suspension of fine solder particles, flux and binding agent) to be applied to the printed-circuit board by screen printing, stencilling or pressure-syringe dispensing before package placement. Driven by legislation and environmental forces the worldwide use of lead-free solder pastes is increasing.

Several methods exist for reflowing; for example, convection or convection/infrared heating in a conveyor type oven. Throughput times (preheating, soldering and cooling) vary between 100 seconds and 200 seconds depending on heating method.

Typical reflow peak temperatures range from 215 °C to 270 °C depending on solder paste material. The top-surface temperature of the packages should preferably be kept:

- below 225 °C (SnPb process) or below 245 °C (Pb-free process)
  - for all BGA, HTSSON..T and SSOP..T packages
  - for packages with a thickness  $\geq 2.5$  mm
  - for packages with a thickness  $< 2.5$  mm and a volume  $\geq 350$  mm<sup>3</sup> so called thick/large packages.
- below 240 °C (SnPb process) or below 260 °C (Pb-free process) for packages with a thickness  $< 2.5$  mm and a volume  $< 350$  mm<sup>3</sup> so called small/thin packages.

Moisture sensitivity precautions, as indicated on packing, must be respected at all times.

### 18.3 Wave soldering

Conventional single wave soldering is not recommended for surface mount devices (SMDs) or printed-circuit boards with a high component density, as solder bridging and non-wetting can present major problems.

To overcome these problems the double-wave soldering method was specifically developed.

If wave soldering is used the following conditions must be observed for optimal results:

- Use a double-wave soldering method comprising a turbulent wave with high upward pressure followed by a smooth laminar wave.
- For packages with leads on two sides and a pitch (e):
  - larger than or equal to 1.27 mm, the footprint longitudinal axis is **preferred** to be parallel to the transport direction of the printed-circuit board;

- smaller than 1.27 mm, the footprint longitudinal axis **must** be parallel to the transport direction of the printed-circuit board.

The footprint must incorporate solder thieves at the downstream end.

- For packages with leads on four sides, the footprint must be placed at a 45° angle to the transport direction of the printed-circuit board. The footprint must incorporate solder thieves downstream and at the side corners.

During placement and before soldering, the package must be fixed with a droplet of adhesive. The adhesive can be applied by screen printing, pin transfer or syringe dispensing. The package can be soldered after the adhesive is cured.

Typical dwell time of the leads in the wave ranges from 3 seconds to 4 seconds at 250 °C or 265 °C, depending on solder material applied, SnPb or Pb-free respectively.

A mildly-activated flux will eliminate the need for removal of corrosive residues in most applications.

## 18.4 Manual soldering

Fix the component by first soldering two diagonally-opposite end leads. Use a low voltage (24 V or less) soldering iron applied to the flat part of the lead. Contact time must be limited to 10 seconds at up to 300 °C.

When using a dedicated tool, all other leads can be soldered in one operation within 2 seconds to 5 seconds between 270 °C and 320 °C.

## 18.5 Package related soldering information

**Table 137: Suitability of surface mount IC packages for wave and reflow soldering methods**

Package <sup>[1]</sup>	Soldering method	
	Wave	Reflow <sup>[2]</sup>
BGA, HTSSON..T <sup>[3]</sup> , LBGA, LFBGA, SQFP, SSOP..T <sup>[3]</sup> , TFBGA, VFBGA, XSON	not suitable	suitable
DHVQFN, HBCC, HBGA, HLQFP, HSO, HSOP, HSQFP, HSSON, HTQFP, HTSSOP, HVQFN, HVSON, SMS	not suitable <sup>[4]</sup>	suitable
PLCC <sup>[5]</sup> , SO, SOJ	suitable	suitable
LQFP, QFP, TQFP	not recommended <sup>[5]</sup> <sup>[6]</sup>	suitable
SSOP, TSSOP, VSO, VSSOP	not recommended <sup>[7]</sup>	suitable
CWQCCN..L <sup>[8]</sup> , PMFP <sup>[9]</sup> , WQCCN..L <sup>[8]</sup>	not suitable	not suitable

[1] For more detailed information on the BGA packages refer to the *(LF)BGA Application Note (AN01026)*; order a copy from your Philips Semiconductors sales office.

[2] All surface mount (SMD) packages are moisture sensitive. Depending upon the moisture content, the maximum temperature (with respect to time) and body size of the package, there is a risk that internal or external package cracks may occur due to vaporization of the moisture in them (the so called popcorn effect). For details, refer to the Drypack information in the *Data Handbook IC26; Integrated Circuit Packages; Section: Packing Methods*.

[3] These transparent plastic packages are extremely sensitive to reflow soldering conditions and must on no account be processed through more than one soldering cycle or subjected to infrared reflow soldering with peak temperature exceeding 217 °C ± 10 °C measured in the atmosphere of the reflow oven. The package body peak temperature must be kept as low as possible.

- [4] These packages are not suitable for wave soldering. On versions with the heatsink on the bottom side, the solder cannot penetrate between the printed-circuit board and the heatsink. On versions with the heatsink on the top side, the solder might be deposited on the heatsink surface.
- [5] If wave soldering is considered, then the package must be placed at a 45° angle to the solder wave direction. The package footprint must incorporate solder thieves downstream and at the side corners.
- [6] Wave soldering is suitable for LQFP, QFP and TQFP packages with a pitch (e) larger than 0.8 mm; it is definitely not suitable for packages with a pitch (e) equal to or smaller than 0.65 mm.
- [7] Wave soldering is suitable for SSOP, TSSOP, VSO and VSSOP packages with a pitch (e) equal to or larger than 0.65 mm; it is definitely not suitable for packages with a pitch (e) equal to or smaller than 0.5 mm.
- [8] Image sensor packages in principle should not be soldered. They are mounted in sockets or delivered pre-mounted on flex foil. However, the image sensor package can be mounted by the client on a flex foil by using a hot bar soldering process. The appropriate soldering profile can be provided on request.
- [9] Hot bar soldering or manual soldering is suitable for PMFP packages.

## 19. Revision history

**Table 138: Revision history**

Document ID	Release date	Data sheet status	Change notice	Doc. number	Supersedes
SAA7114_3	20060117	Product data sheet	CPCN200505019	-	SAA7114_2
Modifications:					
					<ul style="list-style-type: none"><li>• The format of this data sheet has been redesigned to comply with the new presentation and information standard of Philips Semiconductors</li><li>• <a href="#">Table 135</a>: Digital outputs; LOW-level output voltage for clocks corrected from -0.5 V to 0 V</li><li>• Package outline changed from SOT472-1 to SOT700-1</li></ul>
SAA7114_2	20040303	Product specification	-	9397 750 11429	SAA7114H_1
SAA7114H_1	20000315	Preliminary specification	-	9397 750 05976	-

## 20. Data sheet status

Level	Data sheet status [1]	Product status [2][3]	Definition
I	Objective data	Development	This data sheet contains data from the objective specification for product development. Philips Semiconductors reserves the right to change the specification in any manner without notice.
II	Preliminary data	Qualification	This data sheet contains data from the preliminary specification. Supplementary data will be published at a later date. Philips Semiconductors reserves the right to change the specification without notice, in order to improve the design and supply the best possible product.
III	Product data	Production	This data sheet contains data from the product specification. Philips Semiconductors reserves the right to make changes at any time in order to improve the design, manufacturing and supply. Relevant changes will be communicated via a Customer Product/Process Change Notification (CPCN).

[1] Please consult the most recently issued data sheet before initiating or completing a design.

[2] The product status of the device(s) described in this data sheet may have changed since this data sheet was published. The latest information is available on the Internet at URL <http://www.semiconductors.philips.com>.

[3] For data sheets describing multiple type numbers, the highest-level product status determines the data sheet status.

## 21. Definitions

**Short-form specification** — The data in a short-form specification is extracted from a full data sheet with the same type number and title. For detailed information see the relevant data sheet or data handbook.

**Limiting values definition** — Limiting values given are in accordance with the Absolute Maximum Rating System (IEC 60134). Stress above one or more of the limiting values may cause permanent damage to the device. These are stress ratings only and operation of the device at these or at any other conditions above those given in the Characteristics sections of the specification is not implied. Exposure to limiting values for extended periods may affect device reliability.

**Application information** — Applications that are described herein for any of these products are for illustrative purposes only. Philips Semiconductors makes no representation or warranty that such applications will be suitable for the specified use without further testing or modification.

customers using or selling these products for use in such applications do so at their own risk and agree to fully indemnify Philips Semiconductors for any damages resulting from such application.

**Right to make changes** — Philips Semiconductors reserves the right to make changes in the products - including circuits, standard cells, and/or software - described or contained herein in order to improve design and/or performance. When the product is in full production (status 'Production'), relevant changes will be communicated via a Customer Product/Process Change Notification (CPCN). Philips Semiconductors assumes no responsibility or liability for the use of any of these products, conveys no license or title under any patent, copyright, or mask work right to these products, and makes no representations or warranties that these products are free from patent, copyright, or mask work right infringement, unless otherwise specified.

## 22. Disclaimers

**Life support** — These products are not designed for use in life support appliances, devices, or systems where malfunction of these products can reasonably be expected to result in personal injury. Philips Semiconductors

## 23. Trademarks

**Notice** — All referenced brands, product names, service names and trademarks are the property of their respective owners.

**I<sup>2</sup>C-bus** — logo is a trademark of Koninklijke Philips Electronics N.V.

## 24. Contact information

For additional information, please visit: <http://www.semiconductors.philips.com>

For sales office addresses, send an email to: [sales.addresses@www.semiconductors.philips.com](mailto:sales.addresses@www.semiconductors.philips.com)

## 25. Contents

<b>1</b>	<b>General description</b> . . . . .	<b>1</b>	8.3.3.2	Vertical scaler (subaddresses B0h to BFh and E0h to EFh) . . . . .	51
<b>2</b>	<b>Features</b> . . . . .	<b>2</b>	8.3.3.3	Use of the vertical phase offsets . . . . .	52
2.1	Video decoder . . . . .	2	8.4	VBI data decoder and capture (subaddresses 40h to 7Fh) . . . . .	54
2.2	Video scaler . . . . .	2	8.5	Image port output formatter (subaddresses 84h to 87h) . . . . .	55
2.3	VBI data decoder and slicer . . . . .	3	8.5.1	Scaler output formatter (subaddresses 93h and C3h) . . . . .	56
2.4	Audio clock generation . . . . .	3	8.5.2	Video FIFO (subaddress 86h) . . . . .	57
2.5	Digital I/O interfaces . . . . .	3	8.5.3	Text FIFO . . . . .	58
2.6	Miscellaneous . . . . .	3	8.5.4	Video and text arbitration (subaddress 86h) . . . . .	58
<b>3</b>	<b>Applications</b> . . . . .	<b>3</b>	8.5.5	Data stream coding and reference signal generation (subaddresses 84h, 85h and 93h) . . . . .	58
<b>4</b>	<b>Quick reference data</b> . . . . .	<b>4</b>	8.6	Audio clock generation (subaddresses 30h to 3Fh) . . . . .	61
<b>5</b>	<b>Ordering information</b> . . . . .	<b>4</b>	8.6.1	Master audio clock . . . . .	61
<b>6</b>	<b>Block diagram</b> . . . . .	<b>5</b>	8.6.2	Signals ASCLK and ALRCLK . . . . .	62
<b>7</b>	<b>Pinning information</b> . . . . .	<b>6</b>	8.6.3	Other control signals . . . . .	63
7.1	Pinning . . . . .	6	<b>9</b>	<b>Input/output interfaces and ports</b> . . . . .	<b>64</b>
7.2	Pin description . . . . .	8	9.1	Analog terminals . . . . .	64
<b>8</b>	<b>Functional description</b> . . . . .	<b>14</b>	9.2	Audio clock signals . . . . .	64
8.1	Decoder . . . . .	14	9.3	Clock and real-time synchronization signals . . . . .	65
8.1.1	Analog input processing . . . . .	14	9.4	Video expansion port (X port) . . . . .	66
8.1.2	Analog control circuits . . . . .	14	9.4.1	X port configured as output . . . . .	67
8.1.2.1	Clamping . . . . .	16	9.4.2	X port configured as input . . . . .	70
8.1.2.2	Gain control . . . . .	16	9.5	Image port (I port) . . . . .	70
8.1.3	Chrominance and luminance processing . . . . .	19	9.6	Host port for 16-bit extension of video data I/O (H port) . . . . .	72
8.1.3.1	Chrominance path . . . . .	20	9.7	Basic input and output timing diagrams I port and X port . . . . .	73
8.1.3.2	Luminance path . . . . .	24	9.7.1	I port output timing . . . . .	73
8.1.3.3	Brightness Contrast Saturation (BCS) control and decoder output levels . . . . .	30	9.7.2	X port input timing . . . . .	73
8.1.4	Synchronization . . . . .	31	<b>10</b>	<b>I<sup>2</sup>C-bus description</b> . . . . .	<b>76</b>
8.1.5	Clock generation circuit . . . . .	31	10.1	I <sup>2</sup> C-bus format . . . . .	76
8.1.6	Power-on reset and CE input . . . . .	32	10.2	I <sup>2</sup> C-bus details . . . . .	84
8.2	Decoder output formatter . . . . .	34	10.2.1	Subaddress 00h . . . . .	84
8.3	Scaler . . . . .	39	10.2.2	Subaddress 01h . . . . .	84
8.3.1	Acquisition control and task handling (subaddresses 80h, 90h, 91h, 94h to 9Fh and C4h to CFh) . . . . .	40	10.2.3	Subaddress 02h . . . . .	84
8.3.1.1	Input field processing . . . . .	41	10.2.4	Subaddress 03h . . . . .	86
8.3.1.2	Task handling . . . . .	42	10.2.5	Subaddress 04h . . . . .	87
8.3.1.3	Output field processing . . . . .	43	10.2.6	Subaddress 05h . . . . .	87
8.3.2	Horizontal scaling . . . . .	45	10.2.7	Subaddress 06h . . . . .	87
8.3.2.1	Horizontal prescaler (subaddresses A0h to A7h and D0h to D7h) . . . . .	45	10.2.8	Subaddress 07h . . . . .	88
8.3.2.2	Horizontal fine scaling (variable phase delay filter; subaddresses A8h to AFh and D8h to DFh) . . . . .	49	10.2.9	Subaddress 08h . . . . .	88
8.3.3	Vertical scaling . . . . .	50	10.2.10	Subaddress 09h . . . . .	89
8.3.3.1	Line FIFO buffer (subaddresses 91h, B4h and C1h, E4h) . . . . .	50	10.2.11	Subaddress 0Ah . . . . .	90

continued &gt;&gt;

10.2.12	Subaddress 0Bh	91	11.3	Data slicer and data type control part	121
10.2.13	Subaddress 0Ch	91	11.4	Scaler and interfaces	122
10.2.14	Subaddress 0Dh	91	11.4.1	Trigger condition	122
10.2.15	Subaddress 0Eh	92	11.4.2	Maximum zoom factor	122
10.2.16	Subaddress 0Fh	93	11.4.3	Examples	123
10.2.17	Subaddress 10h	93	<b>12</b>	<b>Limiting values</b>	<b>126</b>
10.2.18	Subaddress 11h	93	<b>13</b>	<b>Thermal characteristics</b>	<b>126</b>
10.2.19	Subaddress 12h	94	<b>14</b>	<b>Characteristics</b>	<b>127</b>
10.2.20	Subaddress 13h	96	<b>15</b>	<b>Application information</b>	<b>132</b>
10.2.21	Subaddress 14h	97	<b>16</b>	<b>Test information</b>	<b>134</b>
10.2.22	Subaddress 15h	97	16.1	Boundary scan test	134
10.2.23	Subaddress 16h	98	16.1.1	Initialization of boundary scan circuit	134
10.2.24	Subaddress 17h	98	16.1.2	Device identification codes	134
10.2.25	Subaddress 18h	98	<b>17</b>	<b>Package outline</b>	<b>136</b>
10.2.26	Subaddress 19h	99	<b>18</b>	<b>Soldering</b>	<b>138</b>
10.2.27	Subaddress 1Fh	99	18.1	Introduction to soldering surface mount packages	138
10.3	Programming register audio clock generation	100	18.2	Reflow soldering	138
10.3.1	Subaddresses 30h to 32h	100	18.3	Wave soldering	138
10.3.2	Subaddresses 34h to 36h	100	18.4	Manual soldering	139
10.3.3	Subaddress 38h	100	18.5	Package related soldering information	139
10.3.4	Subaddress 39h	100	<b>19</b>	<b>Revision history</b>	<b>141</b>
10.3.5	Subaddress 3Ah	100	<b>20</b>	<b>Data sheet status</b>	<b>142</b>
10.4	Programming register VBI data slicer	101	<b>21</b>	<b>Definitions</b>	<b>142</b>
10.4.1	Subaddress 40h	101	<b>22</b>	<b>Disclaimers</b>	<b>142</b>
10.4.2	Subaddresses 41h to 57h	101	<b>23</b>	<b>Trademarks</b>	<b>142</b>
10.4.3	Subaddress 58h	102	<b>24</b>	<b>Contact information</b>	<b>142</b>
10.4.4	Subaddress 59h	102			
10.4.5	Subaddress 5Ah	102			
10.4.6	Subaddress 5Bh	102			
10.4.7	Subaddress 5Dh	102			
10.4.8	Subaddress 5Eh	103			
10.4.9	Subaddress 60h	103			
10.4.10	Subaddresses 61h and 62h	103			
10.5	Programming register interfaces and scaler part	103			
10.5.1	Subaddress 80h	103			
10.5.2	Subaddresses 83h to 87h	104			
10.5.3	Subaddress 88h	108			
10.5.4	Subaddress 8Fh	108			
10.5.5	Subaddresses 90h and C0h	109			
10.5.6	Subaddresses 91h to 93h	110			
10.5.7	Subaddresses 94h to 9Bh	113			
10.5.8	Subaddresses 9Ch to 9Fh	114			
10.5.9	Subaddresses A0h to A2h	114			
10.5.10	Subaddresses A4h to A6h	116			
10.5.11	Subaddresses A8h to AEh	116			
10.5.12	Subaddresses B0h to BFh	117			
<b>11</b>	<b>Programming start setup</b>	<b>119</b>			
11.1	Decoder part	119			
11.2	Audio clock generation part	120			



© Koninklijke Philips Electronics N.V. 2006

All rights are reserved. Reproduction in whole or in part is prohibited without the prior written consent of the copyright owner. The information presented in this document does not form part of any quotation or contract, is believed to be accurate and reliable and may be changed without notice. No liability will be accepted by the publisher for any consequence of its use. Publication thereof does not convey nor imply any license under patent- or other industrial or intellectual property rights.

Date of release: 17 January 2006  
Document number: SAA7114\_3

Published in The Netherlands