REALTEK SINGLE-CHIP USB To FAST ETHERNET CONTROLLER WITH MII INTERFACE RTL8150L(M)

1 Features:

- RTL8150L supports 48 pins LQFP
- RTL8150LM supports 100 pins LQFP
- Integrated Fast Ethernet MAC, Physical chip and transceiver in one chip
- Supports 10 Mb/s and 100 Mb/s N-way Auto-negotiation operation.
- Single-chip USB to Fast Ethernet controller
 - ✧ Compliant to USB interface ver 1.0/1.1.
 - ✧ Full-Speed (12 Mb/s) USB Device
 - ✧ Supports all USB standard commands
 - ✧ Supports Suspend/Resume detection logic
 - ✧ Supports 4 endpoints
 - 1 control endpoint with maximum 8-byte packet
 - 1 bulk IN endpoint with 64 bytes/packet
 - 1 bulk OUT endpoint with 64 bytes/packet
 - 1 interrupt IN endpoint with 8 bytes/packet
- RTL8150LM supports MII interface
- Supports Wake-On-LAN function and remote wakeup (Magic Packet*, LinkChg and Microsoft® wake-up frame).
- 18K bytes SRAM built in.(2k bytes for Tx buffer, and 16k bytes for Rx buffer).
- Uses 93C46 to store resource configuration, ID parameter,etc.
- Supports LED pins for various network activity indications.
- Half/Full duplex 10/100Mbps operation.
- Supports Full Duplex Flow Control (IEEE 802.3x)
- Uses 25MHz crystal as the internal clock source.
- 5 V power supply

*Third-party brands and names are the property of their respective owners.

2 General Description

The RTL8150L controller is a 48-pin LQFP single chip that supports USB to 10/100Mbps Fast Ethernet function. To connect to Home PNA 1.0 PHY or HomePNA 2.0 PHY, the 100-pin RTL8150LM provides MII interface supporting the MII transmit clock from 0.1 MHz to 25 MHz.

The Realtek RTL8150L(M) is a highly integrated and cost-effective single-chip Fast Ethernet controller that provides USB to Fast Ethernet capability, and full compliance with IEEE 802.3u 100Base-T specifications and IEEE 802.3x Full Duplex Flow Control. It also supports power management for modern operating systems that is capable of Operating System Directed Power Management (OSPM) to achieve the most efficient power management. Besides the PM feature, the RTL8150L(M) also supports remote wake-up (including AMD Magic Packet*, LinkChg, and Microsoft® wake-up frame).

For sake of cost-effective, the RTL8150L(M) only requires one 25MHz crystal as its internal clock source, and requires no “glue” logic or external memory.

The RTL8150L(M) keeps network maintenance cost low and eliminates usage barriers. It is the easiest way to connect a PC to the computer network without opening the cover, adding cards, reconfiguring software, or any of the other technicalities.

3 Pin Assignment

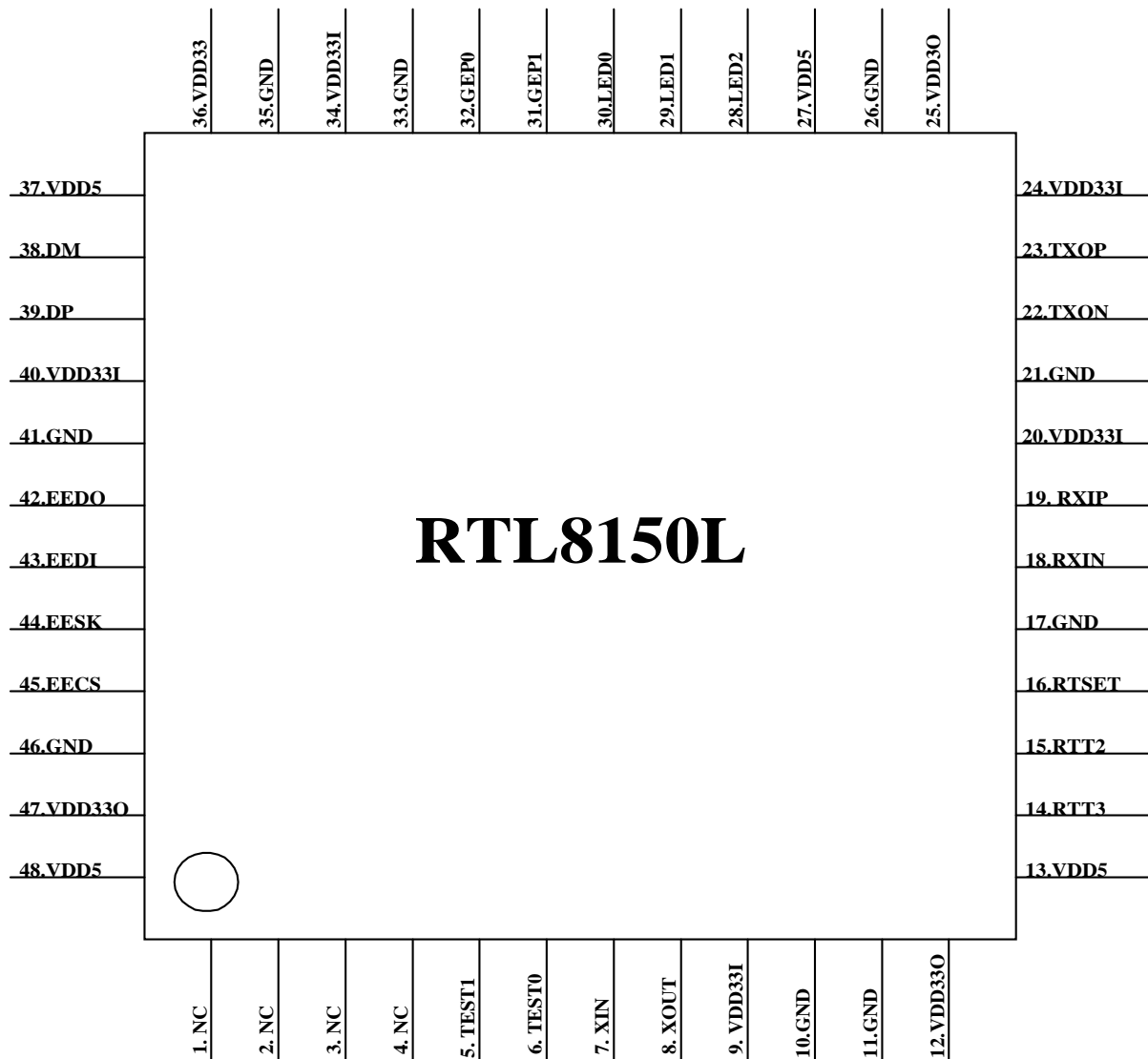

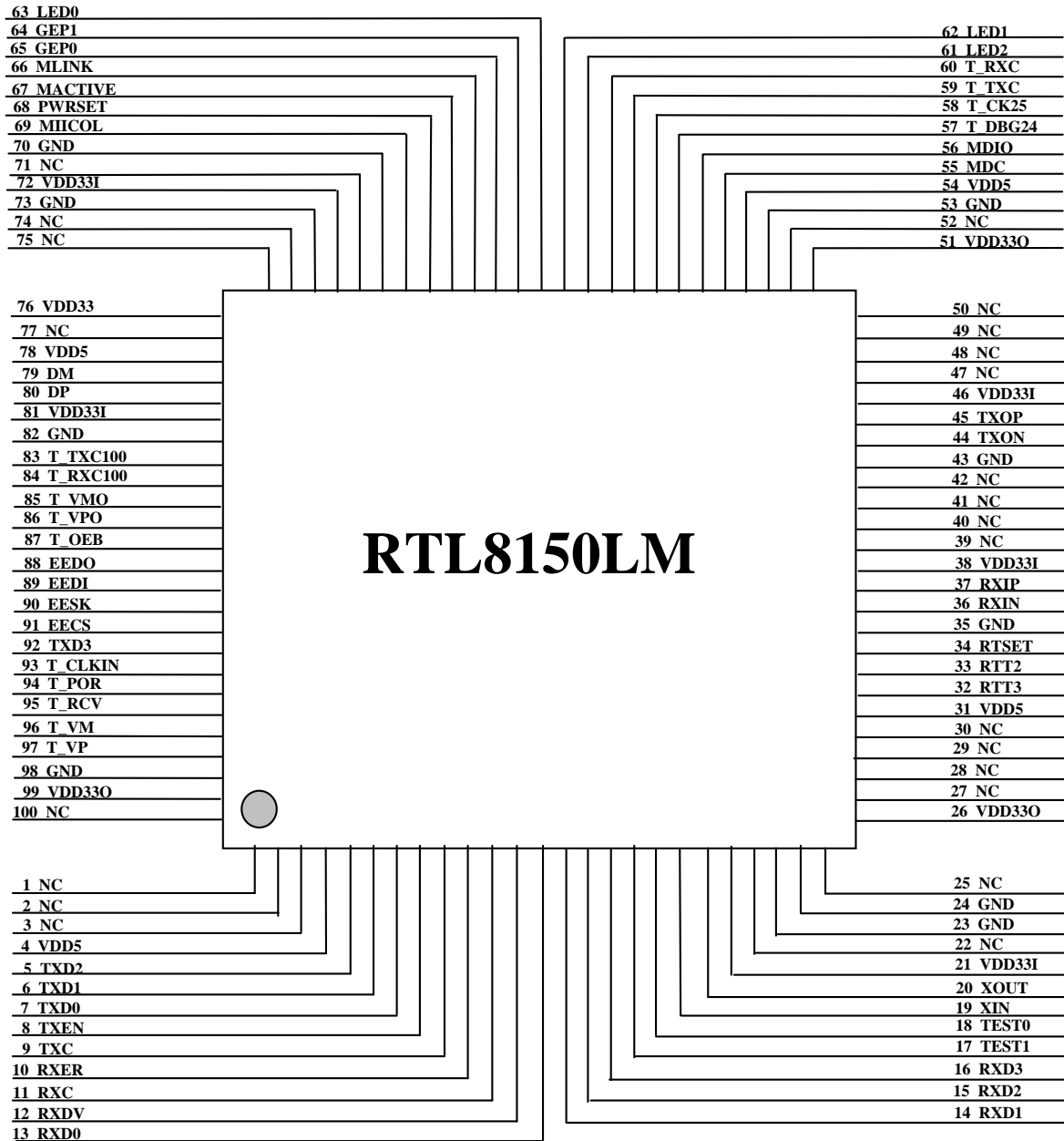

4 Pin Descriptions

4.1 RTL8150L Pin Descriptions

4.1.1 POWER PINS

Symbol	Type	Pin No	Description
VDD5	P	13,27,37,48	5.0V power supply as internal regulators input
VDD33O	P	12,25,47	3.3V power output from internal regulators Pin 47: Digital power
VDD33I	P	9,20,24,34,40	3.3V power Pin 40: Digital power
GND	P	10,11,17,21,26,33,35, 41,46	Ground
VDD33	P	36	3.3V Standby power

4.1.2 USB INTERFACE

Symbol	Type	Pin No	Description
DM	I/O	38	Negative data line of USB differential data bus
DP	I/O	39	Positive data line of USB differential data bus

4.1.3 10/100 BASE-T UTP INTERFACE

Symbol	Type	Pin No	Description
TXD+	O	23	10/100 BASE-T transmit data
TXD-	O	22	10/100 BASE-T transmit data
RXIN+	I	19	10/100 BASE-T receive data
RXIN-	I	18	10/100 BASE-T receive data
X1	I	7	25 MHz crystal input
X2	O	8	25 MHz crystal output

4.1.4 LED Interface

Symbol	Type	Pin No	Description																				
LED0, 1, 2	O	30,29,28	LED pins(active low) <table border="1" data-bbox="755 1659 1445 1780"> <thead> <tr> <th>LEDS1-0</th> <th>00</th> <th>01</th> <th>10</th> <th>11</th> </tr> </thead> <tbody> <tr> <td>LED0</td> <td>TX/RX</td> <td>TX/RX</td> <td>TX</td> <td>TX/RX@ LINK10</td> </tr> <tr> <td>LED1</td> <td>LINK100</td> <td>LINK10/100</td> <td>LINK10/100</td> <td>TX/RX@ LINK100</td> </tr> <tr> <td>LED2</td> <td>LINK10</td> <td>FULL</td> <td>RX</td> <td>FULL</td> </tr> </tbody> </table> <p>During power down mode, the LED's are OFF if SYSLED in configuration register 1 is set.</p>	LEDS1-0	00	01	10	11	LED0	TX/RX	TX/RX	TX	TX/RX@ LINK10	LED1	LINK100	LINK10/100	LINK10/100	TX/RX@ LINK100	LED2	LINK10	FULL	RX	FULL
LEDS1-0	00	01	10	11																			
LED0	TX/RX	TX/RX	TX	TX/RX@ LINK10																			
LED1	LINK100	LINK10/100	LINK10/100	TX/RX@ LINK100																			
LED2	LINK10	FULL	RX	FULL																			

4.1.5 EEPROM INTERFACE

Symbol	Type	Pin No	Description
EES	O	45	93C46 chip select
EESK	O	44	93C46 clock
EEDI	O	43	93C46 data input
EEDO	I	42	93C46 data output

4.1.6 TEST AND THE OTHER PINS

Symbol	Type	Pin No	Description
RTT2-3	TEST	15,14	Chip test pins.
TEST0-1	TEST	6,5	Chip test pins.
RTSET	I/O	16	This pin must be pulled low by a 1.69K Ω resistor.
GEPO-1	I/O	32,31	General purpose pin 0,1
NC		1,2,3,4	Reserved

4.2 RTL8150LM Pin Descriptions

4.2.1 RTL8150LM POWER PINS

Symbol	Type	Pin No	Description
VDD5	P	4,31,54,78	5.0V power supply as internal regulators input
VDD330	P	26,51,99	3.3V power output from internal regulators Pin 99: Digital power
VDD331	P	21,38,46,72,81	3.3V power Pin 81: Digital power
GND	P	23,24,35,43,53,70,73,82,98	Ground
VDD33	P	76	3.3V Standby power

4.2.2 RTL8150LM USB INTERFACE

Symbol	Type	Pin No	Description
DM	I/O	79	Negative data line of USB differential data bus
DP	I/O	80	Positive data line of USB differential data bus

4.2.3 RTL8150LM 10/100 BASE-T UTP INTERFACE

Symbol	Type	Pin No	Description
TXD+	O	45	10/100 BASE-T transmit data
TXD-	O	44	10/100 BASE-T transmit data

RXIN+	I	37	10/100 BASE-T receive data
RXIN-	I	36	10/100 BASE-T receive data
X1	I	19	25 MHz crystal input
X2	O	20	25 MHz crystal output

4.2.4 RTL8150LM MII INTERFACE

Symbol	Type	Pin No	Description
RXD0-3	I	13,14,15,16	MII receive data 0-3
TXD0-3	O	7,6,5,92	MII transmit data 0-3
TXC	I	9	MII Transmit Clock: 25 MHz or 2.5 MHz Tx clock supplied by the external PMD device.
MIICOL	I	69	MII Collision Detected: This signal is asserted high synchronously by the external physical unit upon detection of a collision on the medium. It will remain asserted as long as the collision condition persists.
TXEN	O	8	MII Transmit Enable: Indicates the presence of valid nibble data on TXD[3:0].
RXC	I	11	MII Receive Clock: 25 MHz or 2.5 MHz Rx clock supplied by the external PMD device.
RXDV	I	12	MII Receive Data Valid: Data valid is asserted by an external PHY when receive data is present on the RXD[3:0], and it is de-asserted at the end of the packet. This signal is valid on the rising edge of the RXC.
RXER	I	10	MII Receive Error: This pin is asserted to indicate that invalid symbol has been detected in 100Mbps MII mode. This signal is synchronized to RXC and can be asserted for a minimum of one receive clock.
MDC	O	55	MII Management Data Clock: Synchronous clock for MDIO data transfer.
MDIO	I/O	56	MII Management Data: Bi-directional signal used to transfer management information.
Mlink	I	66	MII link status notification, indicates to the MAC that external PMD is link Ok or not.
Mactive ^b	I	67	MII active status notification, when Mactive=high, Mlink is low active , and vice versa.

4.2.5 RTL8150LM LED Interface

Symbol	Type	Pin No	Description																				
LED0, 1, 2	O	63,62,61	LED pins(active low) <table border="1" data-bbox="755 1638 1445 1764" style="margin-left: 20px;"> <thead> <tr> <th>LEDS1-0</th> <th>00</th> <th>01</th> <th>10</th> <th>11</th> </tr> </thead> <tbody> <tr> <td>LED0</td> <td>TX/RX</td> <td>TX/RX</td> <td>TX</td> <td>TX/RX@ LINK10</td> </tr> <tr> <td>LED1</td> <td>LINK100</td> <td>LINK10/100</td> <td>LINK10/100</td> <td>TX/RX@ LINK100</td> </tr> <tr> <td>LED2</td> <td>LINK10</td> <td>FULL</td> <td>RX</td> <td>FULL</td> </tr> </tbody> </table> <p>During power down mode, the LED's are OFF if SYSLED in configuration register 0 is set.</p>	LEDS1-0	00	01	10	11	LED0	TX/RX	TX/RX	TX	TX/RX@ LINK10	LED1	LINK100	LINK10/100	LINK10/100	TX/RX@ LINK100	LED2	LINK10	FULL	RX	FULL
LEDS1-0	00	01	10	11																			
LED0	TX/RX	TX/RX	TX	TX/RX@ LINK10																			
LED1	LINK100	LINK10/100	LINK10/100	TX/RX@ LINK100																			
LED2	LINK10	FULL	RX	FULL																			

4.2.6 RTL8150LM EEPROM INTERFACE

Symbol	Type	Pin No	Description
EECS	O	91	93C46 chip select
EESK	O	90	93C46 clock
EEDI	O	89	93C46 data input
EEDO	I	88	93C46 data output

4.2.7 RTL8150LM TEST AND THE OTHER PINS

Symbol	Type	Pin No	Description
RTT2-3	TEST	33,32	Chip test pins.
T_***	TEST	17,18,57,58,59,60,83, 84,85,86,87,93,94,95, 96,97	Chip test pins.
RTSET	I/O	34	This pin must be pulled low by a 1.69K Ω resistor.
GEPO-1	I/O	65,64	General purpose pin 0,1
PWRESETB	O	68	Power-on reset for external PHY, active low
NC		1,2,3,22,25,27,28,29, 30,39,40,41,42,47,48, 49,50,52,71,74,75,77, 100	Reserved

5. SIE –USB Commands

5.1 Vender Memory Read

Setup transaction:

BmReq	bReq	wValueL	wValueH	wIndexL	wIndexH	wLengthL	wLengthH
C0	05	regoffsetL	regoffsetH	00	00	LengL	LengH

Data transaction:

DATA0	DATA1	DATA2	DATA3	DATA4	DATA5	DATA6	DATA7
reg0	reg1	reg2	reg3	reg4	reg5	reg6	reg7

The total length response by 8150L depends on (LengH,LengL) values.

5.2 Vender Memory Write

Setup transaction:

BmReq	bReq	wValueL	wValueH	wIndexL	wIndexH	wLengthL	wLengthH
40	05	regoffsetL	regoffsetH	00	00	LengL	LengH

Data transaction:

DATA0	DATA1	DATA2	DATA3	DATA4	DATA5	DATA6	DATA7
reg0	reg1	reg2	reg3	reg4	reg5	reg6	reg7

Offset 0x1200 to 0x127f register must write by word mode.

5.3 Set address

Setup transaction:

BmReq	bReq	wValueL	wValueH	wIndexL	wIndexH	wLengthL	wLengthH
00	05	addrL	addrH	00	00	00	00

Data transaction: None

5.4 Clear Feature EP0

Setup transaction:

BmReq	bReq	wValueL	wValueH	wIndexL	wIndexH	wLengthL	wLengthH
02	01	00	00	00	00	00	00

Data transaction: None

5.5 Clear Feature EP1

Setup transaction:

BmReq	breq	wValueL	wValueH	wIndexL	wIndexH	wLengthL	wLengthH
02	01	00	00	81	00	00	00

Data transaction: None

5.6 Clear Feature EP2

Setup transaction:

BmReq	bReq	wValueL	wValueH	wIndexL	wIndexH	wLengthL	wLengthH
02	01	00	00	02	00	00	00

Data transaction: None

5.7 Clear Feature EP3

Setup transaction:

BmReq	bReq	wValueL	wValueH	wIndexL	wIndexH	wLengthL	wLengthH
02	01	00	00	83	00	00	00

Data transaction: None

5.8 Set Feature EP1

Setup transaction:

BmReq	bReq	wValueL	wValueH	wIndexL	wIndexH	wLengthL	wLengthH
02	03	00	00	81	00	00	00

Data transaction: None

5.9 Set Feature EP2

Setup transaction:

BmReq	bReq	wValueL	wValueH	wIndexL	wIndexH	wLengthL	wLengthH
02	03	00	00	02	00	00	00

Data transaction: None

5.10 Set Feature EP3

Setup transaction:

2002/2/18

Ver1.40

BmReq	bReq	wValueL	wValueH	wIndexL	wIndexH	wLengthL	wLengthH
02	03	00	00	00	83	00	00

Data transaction: None

5.11 Set Interface 0

Setup transaction:

BmReq	bReq	wValueL	wValueH	wIndexL	wIndexH	wLengthL	wLengthH
01	0B	00	00	00	00	00	00

Data transaction: None

5.12 Set Feature Device

Setup transaction:

BmReq	bReq	wValueL	wValueH	wIndexL	wIndexH	wLengthL	wLengthH
00	03	01	00	00	00	00	00

Data transaction: None

5.13 Clear Feature Device

Setup transaction:

BmReq	bReq	wValueL	wValueH	wIndexL	wIndexH	wLengthL	wLengthH
00	01	01	00	00	00	00	00

Data transaction: None

5.14 Set Config 0

Setup transaction:

BmReq	bReq	wValueL	wValueH	wIndexL	wIndexH	wLengthL	wLengthH
00	09	00	00	00	00	00	00

Data transaction: None

5.15 Set Config 1

Setup transaction:

BmReq	bReq	wValueL	wValueH	wIndexL	wIndexH	wLengthL	wLengthH
00	09	01	00	00	00	00	00

Data transaction: None

5.16 Get Descriptor Device

Setup transaction:

BmReq	bReq	wValueL	wValueH	wIndexL	wIndexH	wLengthL	wLengthH
80	06	00	01	00	00	Lengh_L	Lengh_H

Data transaction:

DATA0	DATA1	DATA2	DATA3	DATA4	DATA5	DATA6	DATA7
12	01	10	01	00	00	00	08
DA	0B	50	81	00	01	01	02
03	01	-	-	-	-	-	-

The total length response by 8150L depends on (LengH,LengL) values.

5.17 Get Descriptor Configuration

Setup transaction:

BmReq	bReq	wValueL	wValueH	wIndexL	wIndexH	wLengthL	wLengthH
80	06	00	02	00	00	Lengh_L	Lengh_H

Data transaction:

DATA0	DATA1	DATA2	DATA3	DATA4	DATA5	DATA6	DATA7
09	02	27	00	01	01	00	A0
50	09	04	00	00	03	FF *	00
FF *	00	07	05	81	02	40	00
00	07	05	02	02	40	00	00
07	05	83	03	08	00	01	-

The total length response by 8150L depends on (LengH,LengL) values.

*The E version is 0xFF ,before E version it is 0x00.

5.18 Get Descriptor String Index 0

Setup transaction:

BmReq	bReq	wValueL	wValueH	wIndexL	wIndexH	wLengthL	wLengthH
80	06	00	03	00	00	Lengh_L	Lengh_H

Data transaction:

DATA0	DATA1	DATA2	DATA3	DATA4	DATA5	DATA6	DATA7
04	03	04	09	-	-	-	-

The total length response by 8150L depends on (LengH,LengL) values.

5.19 Get Descriptor String Index 1

Setup transaction:

BmReq	bReq	wValueL	wValueH	wIndexL	wIndexH	wLengthL	wLengthH
80	06	01	03	09	04	Lengh_L	Lengh_H

Data transaction:(REALTEK)

DATA0	DATA1	DATA2	DATA3	DATA4	DATA5	DATA6	DATA7
10	03	52	00	45	00	41	00
4C	00	54	00	45	00	4B	00

The total length response by 8150L depends on (LengH,LengL) values.

5.20 Get Descriptor String Index 2

Setup transaction:

BmReq	bReq	wValueL	wValueH	wIndexL	wIndexH	wLengthL	wLengthH
80	06	02	03	09	04	Lengh_L	Lengh_H

Data transaction:(USB 10/100 LAN)

DATA0	DATA1	DATA2	DATA3	DATA4	DATA5	DATA6	DATA7
1E	03	55	00	53	00	42	00
20	00	31	00	30	00	2F	00
31	00	30	00	30	00	20	00
4C	00	41	00	4E	00	-	-

5.21 Get Descriptor String Index 3

Setup transaction:

BmReq	bReq	wValueL	wValueH	wIndexL	WindexH	wLengthL	wLengthH
80	06	03	03	09	04	Lengh_L	Lengh_H

Data transaction:

DATA0	DATA1	DATA2	DATA3	DATA4	DATA5	DATA6	DATA7
0A	03	30	00	30	00	30	00
31	00	-	-	-	-	-	-

The total length response by 8150L depends on (LengH,LengL) values.

5.22 Get Config

Setup transaction:

BmReq	bReq	wValueL	wValueH	wIndexL	wIndexH	wLengthL	wLengthH
80	08	00	00	00	00	01	00

Data transaction:

DATA0	DATA1	DATA2	DATA3	DATA4	DATA5	DATA6	DATA7
Value	-	-	-	-	-	-	-

5.23 Get Status Device

Setup transaction:

BmReq	bReq	wValueL	wValueH	wIndexL	wIndexH	wLengthL	wLengthH
80	00	00	00	00	00	02	00

Data transaction:

DATA0	DATA1	DATA2	DATA3	DATA4	DATA5	DATA6	DATA7
Value	Value	-	-	-	-	-	-

5.24 Get Status EP0

Setup transaction:

BmReq	bReq	wValueL	wValueH	wIndexL	wIndexH	wLengthL	wLengthH
82	00	00	00	00	00	02	00

Data transaction:

DATA0	DATA1	DATA2	DATA3	DATA4	DATA5	DATA6	DATA7
Value	Value	-	-	-	-	-	-

5.25 Get Status EP1

Setup transaction:

BmReq	bReq	wValueL	wValueH	wIndexL	wIndexH	wLengthL	wLengthH
82	00	00	00	81	00	02	00

Data transaction:

DATA0	DATA1	DATA2	DATA3	DATA4	DATA5	DATA6	DATA7
Value	value	-	-	-	-	-	-

5.26 Get Status EP2

Setup transaction:

BmReq	bReq	wValueL	wValueH	wIndexL	wIndexH	wLengthL	wLengthH
82	00	00	00	02	00	02	00

Data transaction:

DATA0	DATA1	DATA2	DATA3	DATA4	DATA5	DATA6	DATA7
Value	value	-	-	-	-	-	-

5.27 Get Status EP3

Setup transaction:

BmReq	bReq	wValueL	wValueH	wIndexL	wIndexH	wLengthL	wLengthH
82	00	00	00	83	00	02	00

Data transaction:

DATA0	DATA1	DATA2	DATA3	DATA4	DATA5	DATA6	DATA7
Value	Value	-	-	-	-	-	-

5.28 Get Status Interface 0

Setup transaction:

BmReq	bReq	wValueL	wValueH	wIndexL	wIndexH	wLengthL	wLengthH
81	00	00	00	00	00	02	00

Data transaction:

DATA0	DATA1	DATA2	DATA3	DATA4	DATA5	DATA6	DATA7
Value	value	-	-	-	-	-	-

5.29 Get Interface 0

Setup transaction:

BmReq	bReq	wValueL	wValueH	wIndexL	wIndexH	wLengthL	wLengthH
81	0A	00	00	00	00	01	00

Data transaction:

DATA0	DATA1	DATA2	DATA3	DATA4	DATA5	DATA6	DATA7
value	-	-	-	-	-	-	-

6. Memory Allocation

\$0000H~\$011FH----- Reserved

\$0120H~\$01FFH----- RTL8150L(M) REGISTER

\$1200H~\$127FH-----Serial EEPROM(9346)

Offset	Type	Pin No	Description
0120h-0125h	R/W*	IDR0-5	Ethernet Address ,load from 93C46
0126h-012Dh	R/W	MAR0-7	Multicast register
012Eh	R/W	CR	Command Register
012Fh	R/W	TCR	Transmit configuration register
0130-0131h	R/W	RCR	Receive configuration register
0132h	R/W	TSR	Transmit status register
0133h	R/W	RSR	Receive status register
0134h	R/W	Reserved	-
0135h	R/W*	CON0	Configuration register0
0136h	R/W*	CON1	Configuration register1
0137h	R/W	MSR	Medium status
0138h	R/W	PHYADD	MII PHY address select
0139-013Ah	R/W	PHYDAT	MII PHY data
013Bh	R/W	PHYCNT	MII PHY control
013Ch	R/W	Reserved	
013Dh	R/W*	GPPC	General purpose pin control
013Eh	R/W	WAKECNT	Wake up event control
0140h-0141h	R/W*	BMCR	Basic mode control register
0142h-0143h	R	BMSR	Basic mode status register
0144h-0145h	R/W*	ANAR	Auto-negotiation advertisement register
0146h-0147h	R/W	ANLP	Auto-negotiation link partner ability register
0148h-0149h	R/W	AER	Auto-negotiation expansion register
014Ah-014Bh	R/W	NWAYT	Nway test register
014Ch-014Dh	R/W	CSCR	CS configuration register
014Eh-014Fh	R/W	CRC0	Power Management CRC register for wakeup frame0
0150h-0151h	R/W	CRC1	Power Management CRC register for wakeup frame1
0152h-0153h	R/W	CRC2	Power Management CRC register for wakeup frame2
0154h-0155h	R/W	CRC3	Power Management CRC register for wakeup frame3
0156h-0157h	R/W	CRC4	Power Management CRC register for wakeup frame4
0158h-015Fh	R/W	BYEMASK0	Power Management wakeup frame0(64bit) bytemask
0160h-0167h	R/W	BYEMASK 1	Power Management wakeup frame1(64bit) bytemask
0168h-016Fh	R/W	BYEMASK 2	Power Management wakeup frame2(64bit) bytemask
0170h-0177h	R/W	BYEMASK 3	Power Management wakeup frame3(64bit) bytemask
0178h-017Fh	R/W	BYEMASK 4	Power Management wakeup frame4(64bit) bytemask
0180h-0183h	R/W	PHY1	PHY parameter 1
0184h	R /W	PHY2	PHY parameter 2
0186h-0189h	R/W	TW1	Twister parameter 1
018Ah-01ff		Reserved	

* : denotes auto-loaded from 93C46 during chip initialization.

7. Register Descriptions

7.1 Command Register (Offset 012Eh, R/W)

Bit	Symbol	Description	Default/Attribute
7-6	-	Reserved	-
5	WEPROM	1:EEPROM write enable 0: disable The EEPROM map from 0x1200 to 127fh. Write 0x1200 equal to program EEPROM offset 0x00. Write to EEPROM must use WORD mode access at a time. The read EEPROM have not limit.	0,R/W
4	SOFT_RST	Reset: Setting to 1 forces the RTL8150L(M) to a software reset state which disables the transmitter and receiver, reinitializes the FIFOs, resets the system buffer pointer to the initial value , Rx buffer is empty). The values of IDR0-5 and MAR0-7 will have no changes. This bit is 1 during the reset operation, and is cleared to 0 by the RTL8150L(M) when the reset operation is complete.	0,R/W
3	RE	Ethernet 10/100M receive enable	0,R/W
2	TE	Ethernet 10/100M transmit enable	0,R/W
1	EP3CLREN	1: Enable clearing the performance counter of EP3 after EP3 access. 0: Disable	0,R/W
0	AUTOLOAD	1: Auto-load the contents of 93c46 into RTL8150L(M)'s registers. This bit is self clearing after load complete.	0,R/W

7.2 Transmit Configuration Register (Offset 012Fh, R/W)

Bit	Symbol	Description	Default/Attribute
7-6	TXRR1, 0	Tx Retry Count: These 2 bits are used to specify additional transmission retries in multiple of 16(IEEE 802.3 CSMA/CD retry count). If the TXRR is set to 0, the transmitter will re-transmit 16 times before aborting due to excessive collisions if the TXRR is set to a value greater than 0, the transmitter will re-transmit a number of times equals to the following formula before aborting: Total retries = 16 + (TXRR * 16) The ECOL bit in the TSR register will be set if transmit abort due to excessive collision.	0,R/W
5	Reserve	-	-
4,3	IFG1, 0	Interframe Gap Time: This field allows the user to adjust the interframe gap time below the standard: 9.6 us for 10Mbps, 960 ns for 100Mbps. The time can be programmed from 9.6 us to .84 us (10Mbps) and 960ns to 840ns (100Mbps). The formula for the inter frame gap is: 10 Mbps 8.4us + 0.4(IFG(1:0)) us 100 Mbps 840ns + 40(IFG(1:0)) ns	0,R/W
2, 1	Reserved	-	-
0	NOCRC	1: There's no CRC appended at the end of a packet. 0: There's CRC appended at the end of a packet.	0,R/W

7.3 Receive Configuration Register (Offset 0130h-0131h, R/W)

Bit	Symbol	Description	Default/ Attribute
15-8	-	Reserved	-
7	TAIL	0: CRC field forward to HOST 1: Rx Header forward to HOST. The first two bytes of CRC field are replaced by receive header.	0,R/W
6	AER	1:Accept CRC error packet	0,R/W
5	AR	1: Accept RUNT packet (<64 bytes)	0,R/W
4	AM	1: Accept all multicast packets enumerated in the driver's multicast address list. 0: Disabled.	0,R/W
3	AB	1: Accept broadcast packets 0: Reject broadcast packets.	0,R/W
2	AD	1: Packets received containing a destination address that match the MAC address of the networking device are accepted. 0: Disabled.	0,R/W
1	AAM	1: Accept all multicast frames received by the networking device, including the ones enumerated in the device's multicast address list, 0: Disable.	0,R/W
0	AAP	1: Accept all physical frames 0: Disable.	0,R/W

7.4 Transmit Status Register(Offset 0132h)

Bit	Symbol	Description	Default/ Attribute
7-6	-	Reserved	-
5	ECOL	1: Excessive collision indication	R
4	LCOL	1: Late collision indication	R
3	LOSS_CRIS	1: Loss of carrier indication	R
2	JBR	1: Jaber time out indication	R
1	TX_BUF_EMPTY	1: Tx buffer empty indication	R
0	TX_BUF_FULL	1: Tx buffer full indication	R

Note: TSR register will be cleared to the default value after read or EP3 access.

7.5 Receive Status Register(Offset 0133h)

Bit	Symbol	Description	Default/ Attribute
7	WEVENT	Wake Up Event indication: 1: Wakeup event occurs	R
6	RX_BUF_FULL	Rx Buffer Full indication	R

RTL8150(M)

5	LKCHG	Link Change indication	R
4	RUNT	Runt Packet indication 1: The received packet length is smaller than 64 bytes.	R
3	LONG	Long Packet indication 1: The size of the received packet exceeds 4k bytes.	R
2	CRC	CRC Error indication. 1: The received packet is checked with CRC error.	R
1	FAE	Frame Alignment Error: 1: Indicates that a frame alignment error occurred on this received packet.	R
0	ROK	Receive OK indication. 1: Indicate that a packet is received without error.	R

Note: RSR register will be cleared to the default value after read or EP3 access.

7.6 Configuration Register 0(Offset 0135h, R/W)

Bit	Symbol	Description	Default/Attribute
7	SUSLED	0 : LED pins are driven high to turn off LED during suspend.	0,R/W
6	PARAM_EN	Parameter Enable: (These parameters are used in 100Mbps mode.) 1: PHY1_PARM, PHY2_PARM, TW_PARM can be modified through access to register 0180H~0189H. 0: Disable Note: Each time 93C46 auto-load process is executed, the PHY1_PARM, PHY2_PARM, TW_PARM will be re-loaded the default value from 93C46.	0,R/W
4-5	-	Reserved	-
3	LDPS	Link Down Power Saving mode: 1: Disable. 0: Enable. When the ethernet cable is disconnected (Link Down), part of analog circuit will be powered down in order to save power. The other part of analog circuits relating to SD signal monitoring and 100M signal receiving are not powered down in case the cable is re-connected and link should be re-established again.	0,R/W
2	MSEL	Medium Select When write : 1:MII mode (disable internal PHY) 0:Auto-detect. The UTP mode will be the default. The RTL8150L(M) is switched to MII mode if the internal PHY is not link OK. When read 1:MII mode: The MAC MII is connected to the MII interface of the external PHY. 0:UTP mode: The MAC MII is connected to the internal PHY.	0,R/W
1-0	LEDS1-0	Refer to LED PIN definition. The default value is auto-loaded from 93C46.	0,R/W

7.7 Configuration Register 1(Offset 0136h, R/W)

Bit	Symbol	Description	Default/Attribute
-----	--------	-------------	-------------------

			Attribute
7	-	Reserved.	-
6	BWF	Broadcast Wakeup Frame Function: 1: Enable Broadcast Wakeup Frame If set_feature command with Feature Selector =DEVICE_REMOTE_WAKEUP is received from USB host and BWF=1, RTL8150L(M) will signal wakeup to the host when correctly receiving a packet with DID=FF FF FF FF FF FF (Broadcast packet),. 0: Disable.	0,R/W
5	MWF	Multicast Wakeup Frame Function: 1: Enable Multicast Wakeup Frame If set_feature command with Feature Selector =DEVICE_REMOTE_WAKEUP is received from USB host and MWF=1, RTL8150L(M) will signal wakeup to the host when correctly receiving multicast packets (packets that survive the multicast hash),. 0: Disable.	0,R/W
4	UWF	Unicast Wakeup Frame Function: 1: Enable Unicast Wakeup Frame If set_feature command with Feature Selector =DEVICE_REMOTE_WAKEUP is received from USB host and UWF=1, RTL8150L(M) will signal wakeup to the host when correctly receiving a packet with DID=IDR0~5. 0: Disable.	0,R/W
2-3	-	Reserved	-
1	LONGWF1	1: The Bytemask3 and Bytemask4 are cascaded to form a 128 byte long Bytemask for long wakeup frame 1, and long wakeup frame 1 use CRC3 as CRC check. When LONGWF1=1, wakeup frame 3 and wakeup frame 4 are disable. 0: Disable LOGNWF1.	0,R/W
0	LONGWF0	1: The Bytemask1 and Bytemask2 are cascaded to form a 128 byte long Bytemask for long wakeup frame 0, and long wakeup frame 0 use CRC1 as CRC check. When LONGWF0=1, wakeup frame 1 and wakeup frame 2 are disabled. 0: Disable LOGNWF0.	0,R/W

7.8 Media Status Register (Offset 0137h, R/W)

Bit	Symbol	Description	Default/Attribute																		
7	TXFCE/ LdTXFCE	Tx Flow Control Enable: The flow control is valid in full-duplex mode only. This register's default value comes from 93C46. <table border="1" data-bbox="621 1627 1252 1896"> <thead> <tr> <th>RTL8150L</th> <th>Remote</th> <th>TXFCE/LdTXFCE</th> </tr> </thead> <tbody> <tr> <td>ANE = 1</td> <td>NWAY FLY mode</td> <td>R/O</td> </tr> <tr> <td>ANE = 1</td> <td>NWAY mode only</td> <td>R/W</td> </tr> <tr> <td>ANE = 1</td> <td>No NWAY</td> <td>R/W</td> </tr> <tr> <td>ANE = 0 & full-duplex mode</td> <td>-</td> <td>R/W</td> </tr> <tr> <td>ANE = 0 & half-duplex mode</td> <td>-</td> <td>Invalid</td> </tr> </tbody> </table>	RTL8150L	Remote	TXFCE/LdTXFCE	ANE = 1	NWAY FLY mode	R/O	ANE = 1	NWAY mode only	R/W	ANE = 1	No NWAY	R/W	ANE = 0 & full-duplex mode	-	R/W	ANE = 0 & half-duplex mode	-	Invalid	R/W
RTL8150L	Remote	TXFCE/LdTXFCE																			
ANE = 1	NWAY FLY mode	R/O																			
ANE = 1	NWAY mode only	R/W																			
ANE = 1	No NWAY	R/W																			
ANE = 0 & full-duplex mode	-	R/W																			
ANE = 0 & half-duplex mode	-	Invalid																			

RTL8150(M)

		NWAY FLY mode : NWAY with flow control capability NWAY mode only : NWAY without flow control capability	
6	RXFCE	RX Flow control Enable: The flow control is enabled in full-duplex mode only. The default value comes from 93C46 .	R/W
5	Reserved	-	-
4	Duplex	1: Indicate that the current link is full-duplex 0: Indicate that the current link is half-duplex	R
3	SPEED_100	1: Indicate that the current link is in 100Mbps mode. 0: Indicate that the current link is in 10Mbps mode.	R
2	LINK	Link status. 1: Link OK. 0: Link Fail.	R
1	TXPF	1: Indicate that RTL8150L(M) sends pause packet. 0: Indicate that RTL8150L(M) has sent timer done packet to release remote station from pause Tx state.	R
0	RXPf	1: Indicate that RTL8150L(M) is in Backoff state because a pause packet from remote station has been receipt. 0: Indicate that RTL8150L(M) is not in pause state.	R

7.9 MII PHY Address(Offset 0138h, R/W)

Bit	Symbol	Description	Default/Attribute
7-5	Reserved		-
4-0	PHYADD	MII PHY Address select	R/W

7.10 MII PHY DATA(Offset 0139h-013Ah, R/W)

Bit	Symbol	Description	Default/Attribute
15-0	MIIDAT	Data read from MII PHY or data that is to be written to MII PHY.	R/W

7.11 MII PHY Access Control(Offset 013Bh, R/W)

Bit	Symbol	Description	Default/Attribute
7	Reserved		-
6	PHYOWN	Own bit: RTL8150L(M) will initiate a MII management data transaction if this bit is set 1 by software. After transaction, this bit is auto cleared by RTL8150L.	0,R/W
5	RWCR	MII management data R/W control 1: write, 0: read	R/W
4-0	PHYOFF	PHY register offset	R/W

7.12 General Purpose Register(Offset 013Dh, R/W)

Bit	Symbol	Description/Usage	Default/Attribute
7-5	GEPREG1~3	Reserved	-
4	GEPREG0	General purpose bit 1: Supports external Home PNA PHY	RO
3	GEP1DAT	If GEP1RW is set 1, the GEP1 pin will reflect the value of GEP1DAT, else GEP1DAT will reflect the value of GEP1 pin.	R/W
2	GEP1RW	General purpose pin control bit: 0: The corresponding GEP1 pin is considered input 1: The corresponding GEP1 pin is considered output	R/W
1	GEP0DAT	If GEP0RW is set 1, the GEP0 pin will reflect the value of GEP0DAT, else GEP0DAT will reflect the value of GEP0 pin.	R/W
0	GEP0RW	General purpose pin control bit: 0: The corresponding GEP0 pin is considered input 1: The corresponding GEP0 pin is considered output	R/W

If GEPRW=0 ,READ only

7.13 Wake Up Event Control(Offset 013E, R/W)

Bit	Symbol	Description/Usage	Default/Attribute
7	Reserved		-
6	LKWEN	Link change wake-up enable	0, R/W
5	MAGWEN	Magic Packet wake-up enable	0, R/W
4	WUF4EN	Wake up frame 4 enable	0, R/W
3	WUF3EN	Wake up frame 3 enable	0, R/W
2	WUF2EN	Wake up frame 2 enable	0, R/W
1	WUF1EN	Wake up frame 1 enable	0, R/W
0	WUF0EN	Wake up frame 0 enable	0, R/W

Note: RTL8150L(M) will signal wakeup to the host only when the following two conditions are met:

1. The host has send set_feature_device command.
2. One of the wakeup frame function has been enabled and triggered.

7.14 Basic Mode Control Register (Offset 0140h-0141h, R/W)

Bit	Name	Description/Usage	Default/Attribute
15	Reset	This bit, which is self clearing, will reset the control and status registers of PHY into the default states if it is set 1.	0, RW
14	Reserved	-	-
13	Spd_Set	Speed select. 1 = 100Mbps; 0 = 10Mbps. Note: The initial value of this bit comes from 93C46	RW

12	Auto Negotiation Enable (ANE)	This bit enables/disables the NWay auto-negotiation function. 1 = Enable auto-negotiation. If this bit is set, bit 8 and bit13 will be ignored, and the values of bit8 and bit 13 indicate the result of auto negotiation process. 0 = Disable auto-negotiation. Note: The initial value of this bit comes from 93C46	0, RW
11-10	Reserved	-	-
9	Restart Auto Negotiation	This bit allows the NWay auto-negotiation function to be re-initiated. 1 = Re-start auto-negotiation 0 = Normal operation.	0, RW
8	Duplex Mode	This bit sets the duplex mode. 1 = full-duplex 0 = normal operation. Note: This bit's initial value comes from 93C46	0, RW
7-0	Reserved	-	-

7.15 Basic Mode Status Register (Offset 0142h-0143h, R)

Bit	Name	Description/Usage	Default/Attribute
15	100Base-T4	100Base-T4 Capable: 0 = Device not able to perform 100Base-T4 mode	0, RO
14	100Base_TX_FD	100Base-TX Full Duplex Capable: 1 = Device able to perform 100Base-TX in full duplex mode	1, RO
13	100Base_TX_HD	100Base-TX Half Duplex Capable: 1 = Device able to perform 100Base-TX in half duplex mode	1, RO
12	10Base_T_FD	10Base-T Full Duplex Capable: 1 = Device able to perform 10Base-T in full duplex mode	1, RO
11	10_Base_T_HD	10Base-T Half Duplex Capable: 1 = Device able to perform 10Base-T in half duplex mode	1, RO
10-6	-	Reserved	-
5	Auto Negotiation Complete	1 = Auto-negotiation process completed; 0 = Auto-negotiation process not completed.	0, RO
4	Remote Fault	1 = Remote fault condition detected (clear on read); 0 = No remote fault condition detected.	0, RO
3	Auto Negotiation ability	1 = Device is able to perform Auto-Negotiation. 0 = Device not able to perform Auto-Negotiation.	1, RO
2-1		Reserved	
0	Extended Capability	1 = Extended register capabilities; 0 = Basic register set capabilities.	1, RO

7.16 Auto-negotiation Advertisement Register (Offset 0144h-0145h, R/W)

Bit	Name	Description/Usage	Default/Attribute
15	NP	Next Page capability. 0 = Advertise that NP capability not supported by local mode	0, RO

		1 = Advertise NP exchange capability and desire to transfer next page.	
14	ACK	1 = Acknowledge reception of link partner's capability data word.	0, RO
13	RF	1 = Advertise remote fault detection capability; 0 = Do not advertise remote fault detection capability.	0, RW
12-11	-	Reserved	-
10	PAUSE	1 = Advertise flow control supported by local node. 0 = Advertise flow control not supported by local mode.	The default value comes from EEPROM, RO
9	T4	1 = Advertise 100Base-T4 supported by local node; 0 = Advertise 100Base-T4 not supported by local node.	0, RO
8	TXFD	1 = Advertise 100Base-TX full duplex supported by local node; 0 = Advertise 100Base-TX full duplex not supported by local node.	1, RW
7	TX	1 = Advertise 100Base-TX supported by local node; 0 = Advertise 100Base-TX not supported by local node.	1, RW
6	10FD	1 = Advertise 10Base-T full duplex supported by local node; 0 = Advertise 10Base-T full duplex not supported by local node.	1, RW
5	10	1 = Advertise 10Base-T supported by local node; 0 = Advertise 10Base-T not supported by local node.	1, RW
4-0	Selector	Binary encoded selector supported by this node. Currently only CSMA/ CD <00001> is specified. No other protocols are supported.	<00001>, RW

7.17 Auto-Negotiation Link Partner Ability Register

(Offset 0146h-0147h, R)

Bit	Name	Description/Usage	Default/Attribute
15	NP	Next Page Indication: 0 = Link Partner does not desire Next Page Transfer 1 = Link Partner desires Next Page Transfer.	0, RO
14	ACK	1 = link partner acknowledges reception of the capability data word. 0 = Not acknowledged The device's Auto-Negotiation state machine will automatically control this bit based on the incoming FLP bursts.	0, RO
13	RF	Remote Fault: 1 = Remote Fault indicated by Link Partner 0 = No Remote Fault indicated by Link Partner.	0, RO
12-11	Reserved	-	-
10	Pause	1 = Flow control is supported by link partner , 0 = Flow control is not supported by link partner.	0, RO
9	T4	100BASE-T4 Support: 1 = 100Base-T4 is supported by the link partner; 0 = 100Base-T4 not supported by the link partner.	0, RO
8	TXFD	100BASE-TX Full Duplex Support: 1 = 100Base-TX full duplex is supported by the link partner; 0 = 100Base-TX full duplex not supported by the link partner.	0, RO
7	TX	100BASE-TX Support: 1 = 100Base-TX is supported by the link partner; 0 = 100Base-TX not supported by the link partner.	0, RO
6	10FD	10BASE-T Full Duplex Support: 1 = 10Base-T full duplex is supported by the link partner;	0, RO

		0 = 10Base-T full duplex not supported by the link partner.	
5	10	10BASE-T Support: 1 = 10Base-T is supported by the link partner; 0 = 10Base-T not supported by the link partner.	0, RO
4-0	Selector	Protocol Selection Bits: Link Partner's binary encoded protocol selector.	0, RO

7.18 Auto-negotiation Expansion Register (Offset 0148h-0149h, R)

This register contains additional status for NWay auto-negotiation.

Bit	Name	Description/Usage	Default/Attribute
15-5	-	Reserved, This bit is always set to 0.	-
4	MLF	Status indicating if a multiple link fault has occurred. 1 = fault occurred; 0 = no fault occurred.	0, RO
3	LP_NP_ABLE	Status indicating if the link partner supports Next Page negotiation. 1 = supported; 0 = not supported.	0, RO
2	NP_ABLE	This bit indicates if the local node is able to send additional Next Pages.	0, RO
1	PAGE_RX	This bit is set when a new Link Code Word Page has been received. The bit is automatically cleared when the auto-negotiation link partner's ability register (register 146h) is read by management.	0, RO
0	LP_NW_ABLE	1 = link partner supports NWay auto-negotiation.	0, RO

7.19 NWay Test Register (Offset 014Ah-014Bh, R/W)

Bit	Name	Description/Usage	Default/Attribute
15-8	-	Reserved	-
7	NWLPBK	1 = set NWay to loopback mode.	0, RW
6-4	-	Reserved	-
3	ENNWLE	1 = LED0 Pin indicates linkpulse	0, RW
2	FLAGABD	1 = Auto-neg experienced ability detect state	0, RO
1	FLAGPDF	1 = Auto-neg experienced parallel detection fault state	0, RO
0	FLAGLSC	1 = Auto-neg experienced link status check state	0, RO

7.20 CS Configuration Register (Offset 014Ch-014Dh, R/W)

Bit	Name	Description/Usage	Default/Attribute
15	Testfun	1 = Speeds up internal timer for Auto-Negotiation	0, WO
14-10	-	Reserved	-
9	LD	Active low TPI link disable signal. When low, TPI still transmits link pulses and TPI stays in good link state.	1, RW
8	HEART BEAT	1 = HEART BEAT enable	1, RW

		0 = HEART BEAT disable. HEART BEAT function is only valid in 10Mbps mode.	
7	JBEN	1 = enable jabber function. 0 = disable jabber function	1, RW
6	F_LINK_100	Force link-up in 100Mbps for diagnostic purposes. 1 = DISABLE 0 = ENABLE.	1, RW
5	F_Connect	Force connection of the link for diagnostic purposes: 1 = Fore connection 0 = Disable	0, RW
4	-	Reserved	-
3	Con_status	This bit indicates the status of the connection. 1 = valid connected link detected 0 = disconnected link detected.	0, RO
2	Con_status_En	Assertion of this bit configures LED1 pin to indicate connection status.	0, RW
1	-	Reserved	-
0	PASS_SCR	Bypass Scramble function	0, RW

8 EEPROM 93C46 Contents

The 93C46 is a 1K-bit EEPROM. Although it is actually addressed by words, we list its contents by bytes below for convenience.

After the valid duration of the RSTB pin or auto-load command in Command Register(offset 012Eh), the RTL8150L(M) performs a series of EEPROM read operation from the 93C46.

- * If you want to change the Realtek default setting of the content in EEPROM, we suggest that you have Realtek approval.

Bytes	Contents	Description
00h 01h	50h 81h	These 2 bytes contain ID code word for the RTL8150L(M). The RTL8150L(M) will load the contents of EEPROM into the corresponding location if the ID word (8150h) is right.
02h-07h	Ethernet ID	Ethernet ID, After auto-load command or hardware reset, RTL8150L(M) loads Ethernet ID to IDR0-IDR5 of RTL8150L(M)'s.
08h	CONFIG0	RTL8150L(M) Configuration register 0, operational registers offset 0135h.
09h	MSR/BMCR	Bit7-6 map to the bit7-6 of Media Status register (MSR), Bit5, 4, 0 map to the bit13, 12, 8 of Basic Mode Control register (BMCR), Bit2 maps to the bit10 of Auto-negotiation Advertisement Register (ANAR), Bit3, 1 are reserved. If the network speed is set to Auto-Detect mode (i.e. Nway mode), then Bit2=0 means the local RTL8150L(M) supports flow control (IEEE 802.3x) (in this case, Bit10=1 in Auto-negotiation Advertisement Register (offset 146h-147h), and Bit2=1 means the local RTL8150L(M) does not support flow control (in this case, Bit10=0 in Auto-negotiation Advertisement). This is because that there are Nway switch hubs will keep sending flow control pause packets with no reason, if the link partner supports Nway flow control.
0Ah	GEP	General Purpose Pin Control Register (offset 013Dh).
0Bh	UDP	Reserved. Do not change this filed without Realtek approval.
0Ch	ATTR	USB Device Parameter
		USB Configuration characteristics:

		Bit7 is reserved and must be set to one for USB spec. A device configuration that uses power from the bus and a local source reports a non-zero value in MaxPower to indicate the amount of bus power required and sets Bit 6. Bit5 is set one to support remote wakeup. Bit4-0: Reserved and must be reset to zero for USB spec.
0Dh	PHY2_PARM	Reserved. Do not change this filed without Realtek approval. PHY Parameter 2 for RTL8150L(M). Operational register of the RTL8150L(M) is 0184h.
0Eh-11h	PHY1_PARM	Reserved. Do not change this filed without Realtek approval. PHY Parameter 1 for RTL8150L(M). Operational register of the RTL8150L(M) is 0180h-0183h.
12h-15h	TW1_PARM	Reserved. Do not change this filed without Realtek approval. Twister Parameter for RTL8150L(M). Operational registers of the RTL8150L(M) are 0186h-0189h.
16h	MAXPOR	The maximum USB power consumption.
17h	INTERVAL	Interval for pollin endpoint 3 for data transfers. Expressed in milliseconds.
18h-19h	LanguageID	The string in a USB device may support multiple languages. A manufacturer can specify the desired language using a sixteen-bit language ID.
1Ah-1Bh	ManufacturerID	The system manufacturer's ID.
1Ch-1Dh	ProductID	The of a system manufacturer's product ID.
1Eh-27h	Serial number	The product's serial number.
28h-4fh	Manufacturer String	These bytes specify a manufacturer's information for the USB standard request. Maximum string length is 40 bytes.
50h-7dh	Product String	These bytes specify a device's information for the USB standard request. Maximum string length is 46 bytes.
7eh-7fh	Reserved	

8.1 Summary of RTL8150L's registers in the

EEPROM(93C46)

Offset	Name	Type	Bit7	Bit6	Bit5	Bit4	Bit3	Bit2	Bit1	Bit0
00h	ROMID0	R	0	1	0	1	0	0	0	0
01h	ROMID1	R	1	0	0	0	0	0	0	1
02-07h	IDR0-IDR5	R/W								
08h	Config0	R/W	SUSLED	PARAM_EN	-	-	LDPS	MSEL	LEDS1	LEDS0
09h	MSR/ BMCR	R/W	TXFCE	RXFCE	Spd_set	ANE	-	PAUSE	-	FUDUP
0Ah	GPCP	R/W	GEPREG3	GEPREG2	GEPREG1	GEPREG0	GEP1DAT	GEP1RW	GEP0DAT	GEP0RW
0Bh	UDP	R/W	8 bit Read Write							
0Ch	ATTR	R/W	1	0	1	0	0	0	0	0
0Dh	PHY2_PARM	R/W	8 bit Read Write							
0E-11h	PHY1_PARM	R/W	32 bit Read Write							
12h-15h	TW1_PARM	R/W	32 bit Read Write							
16h	MAXPOR	R/W	8 bit Read Write							
17h	Interval	R/W	0	0	0	0	0	0	0	1
18h-19h	Language ID	R/W	16 bit Read Write							
1Ah-1Bh	Manufacture ID	R/W	16 bit Read Write							
1Ch-1Dh	Product ID	R/W	16 bit Read Write							
1Eh-27h	Serial number	R/W	10 bytes Read Write							

28h-4fh	Manufacture String	R/W	40 bytes Read Write
50h-7dh	Product string	R/W	46 bytes Read Write
7eh-7fh	Reserved	-	-

9 Functional Description

9.1 System Block Diagram

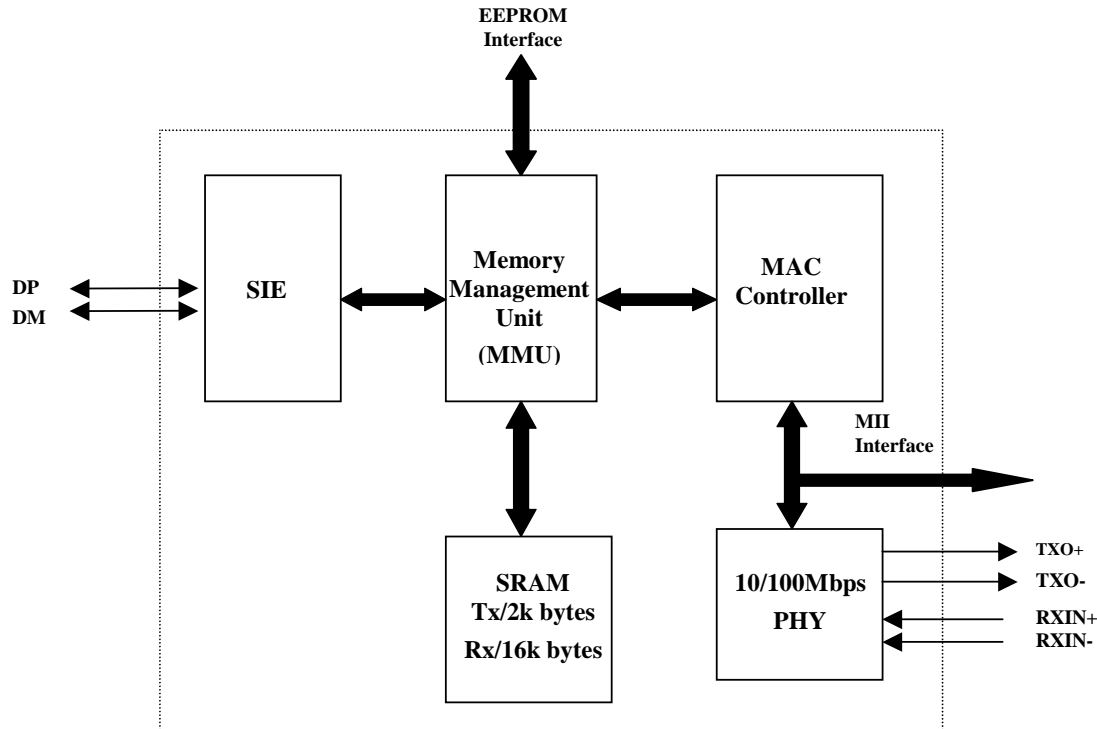

9.2 USB Endpoint SIE function description

The SIE employs a robust hardwired USB protocol implementation so that the entire USB interface operation could be done without firmware intervention. For all three types of EP's, bulk in, bulk out, and interrupt, appropriate responses and handshake signals are generated by SIE. The SIE analog transceiver complies fully with driver and receiver characteristics defined in USB Spec. Rev. 1.1,

9.2.1 Endpoint0

All USB devices support a common accesses mechanism for accessing information through this

control pipe. Associated with the control pipe at endpoint zero is the information required to completely describe the USB device. This pipe also provides the register read and write to RTL8150L .

9.2.2 Endpoint 1 Bulk IN

The MAXIMUM packet size of BULK IIN is 64 bytes. Every Ethernet packet are transfer to HOST by this Endpoint. If the Ethernet packet is larger than 64 bytes, the RTL8150L(M) splits the Ethernet packet into multiples of 64 bytes. The HOST treats the USB packet that less than 64 bytes or equal zero as End of Ethernet packet.

9.2.3 Endpoint 2 Bulk OUT

The HOST sends the USB packet to Ethernet by maximum 64 bytes. If the Ethernet packet is larger than 64 bytes, the Host will send this Ethernet packet in multiples of 64 bytes USB packet. The USB packet less than 64 bytes (including zero byte) indicates the end of a Ethernet packet. The Ethernet packet (containing multiples of USB packets) will be queued in TX FIFO and transmitted later when possible. If the Ethernet packet is transmitted to medium without error, the TX FIFO space which was occupied by the transmitted Ethernet packet will be released again. If the 2K TX FIFO is full, the RTL8150L(M) will respond with a NAK when the host is trying to bulk out more USB packets. It is possible that there are multiples of Ethernet packets in the TX FIFO simultaneously. If a Ethernet packet is to be transmitted but experiences collisions for more than 16 times (default), this is called transmit abort and this packet will be skipped for transmission by RTL8150L(M).

9.2.4 Endpoint 3 interrupt IN

The Interrupt EP (EP3) can be used to poll the current status of RTL8150L(M). The 8 bytes of EP3 contain the information listed below. After EP3 access, the information will be cleared and the counter will be reset if EP3CLREN (Reg 012Eh) is set. The NUMTXOK, RXLOST, CRCERR, COLCNT counters will saturate to 255 if the number of up count events is greater than 255.

The eight bytes of EP3 Interrupt IN contains:

DATA0	DATA1	DATA2	DATA3	DATA4	DATA5	DATA6	DATA7
-------	-------	-------	-------	-------	-------	-------	-------

TSR	RSR	GEP/MSR	WAKSR	NUMTXOK	RXLOST	CRCERR	COLCNT
-----	-----	---------	-------	---------	--------	--------	--------

Offset	Name	Type	Bit7	Bit6	Bit5	Bit4	Bit3	Bit2	Bit1	Bit0
00h	TSR	R	-	-	ECOL	LCOL	LOSS_CRS	JBR	TX_BUF_EMPTY	TX_BUF_FULL
01h	RSR	R	-	RX_BUF_FULL	LKCHG	RUNT	LONG	CRC	FAE	ROK
02h	GEP/MSR	R	GEP1DAT	GEP0DAT	-	Duplex	SPEED_100	LINK	TXPF	RXPf
03h	WAKSR	R		PARM_EN		-	WAKEUP_EV	LKWAKE_EV	MAGIC_EV	BMU_EV
04	TXOK_CNT	R	8-bit counter that counts for valid packets transmitted.							
05h	RXLOST_CNT	R	8-bit counter that counts for packet lost due to Rx buffer overflow.							
06h	CRCERR_CNT	R	8-bit counter that counts for error packets							
07h	COL_CNT	R	8-bit counter that counts for collisions.							

9.3 Ethernet function description

9.3.1 Transmit operation

The USB host initiates a transmission by transferring multiple USB packets into Tx buffer. When MAC receives the end of USB BULK OUT packet from USB host, the RTL8150L(M) starts Ethernet packet transmission.

9.3.2 Receive operation

The incoming Ethernet packet is queued in the RTL8150L(M)'s Rx buffer. While the RTL8150L(M) is receiving the Ethernet packet, it also performs address filtering of multicast packets according to its hash algorithms. When the Ethernet packet is correctly received or the amount of data in the Rx buffer reaches the level defined in the Receive Configuration Register(Early receive function is on), the RTL8150L(M) requests the USB SIE to begin transferring the data to the USB Host memory .

Rx header format (ref. Receive Configuration Register, offset 0130h)

Bit 11-0: Rx bytes count

Bit 12: Valid packet (Packet that is RXOK and not accept error)

Bit 13: Runt packet

Bit 14: Physical match packet

Bit 15: Multicast packet

9.3.3 Collision

If the RTL8150L(M) is not set the full-duplex mode, a collision event occurs when the receive input is not idle while the RTL8150L(M) transmits. If the collision is detected during the preamble transmission, the jam pattern is transmitted after completing the preamble transmission (including the JK symbol pair).

9.3.4 Flow Control

The RTL8150L(M) supports IEEE802.3X flow control to improve performance in full-duplex mode. It recognizes PAUSE packet sent from remote station and backoff transmission according to IEEE802.3X if RXFCE is set, or RTL8150L(M) sends PAUSE packet to remote station when the local RX FIFO exceeds some threshold if the TXFCE is set.

9.3.4.1 Control Frame Transmission

When the free space of RX FIFO is less than 3K bytes. The RTL8150L(M) sends a PAUSE packet with `pause_time(=FFFFh)` to inform the remote station to stop transmission for the specified period of time. After the packets in the RX FIFO are consumed and the free space of RX FIFO is greater than 5K bytes, the RTL8150L(M) sends the PAUSE packet with `pause_time(=0000h)` to inform the remote station to restart transmission.

9.3.4.2 Control Frame Reception

RTL8150L(M) backoffs transmission for the specified period of time when it receives a valid PAUSE packet with `pause_time(=n)`. If the PAUSE packet is received while RTL8150L(M) is transmitting, RTL8150L(M) will start to backoff after current transmission completes.

RTL8150L(M) is free to transmit next packets again if a valid PAUSE packet with `pause_time(=0000h)` is received or the backoff timer(= $n*512$ bit time) elapses.

Note: The PAUSE operation cannot be used to inhibit transmission of MAC Control frames (e.g. PAUSE packet). The N-way flow control capability can be disabled (Refer to Section 8. EEPROM 93C46 Contents for detailed description).

10. ELECTRICAL CHARACTERISTICS

10.1 Temperature Limit Ratings:

Parameter	Minimum	Maximum	Units
Storage temperature	-55	+125	°C
Operating temperature	0	70	°C

10.2 DC CHARACTERISTICS:

10.2.1 Supply voltage (BUS POWER) $V_{bus} = 4.5V$ min. to

5,5V max. $V_{cc} = 3.3V$

Symbol	Parameter	Conditions	Minimum	Maximum	Units
V_{OH}	Minimum High Level Output Voltage	$I_{OH} = -2mA$	$0.9 * V_{cc}$	V_{cc}	V
V_{OL}	Maximum Low Level Output Voltage	$I_{OL} = 8mA$		$0.1 * V_{cc}$	V
V_{IH}	Minimum High Level Input Voltage		$0.5 * V_{cc}$	$V_{cc} + 0.5$	V
V_{IL}	Maximum Low Level Input Voltage		-0.5	$0.3 * V_{cc}$	V
I_{IN}	Input Current	$V_{IN} = V_{CC}$ or GND	50	50	uA
I_{OZ}	Tri-State Output Leakage Current	$V_{OUT} = V_{CC}$ or GND	50	50	uA
I_{CC}	Average Operating Supply Current	$I_{OUT} = 0mA$,		110	mA

10.3 EEPROM Interface

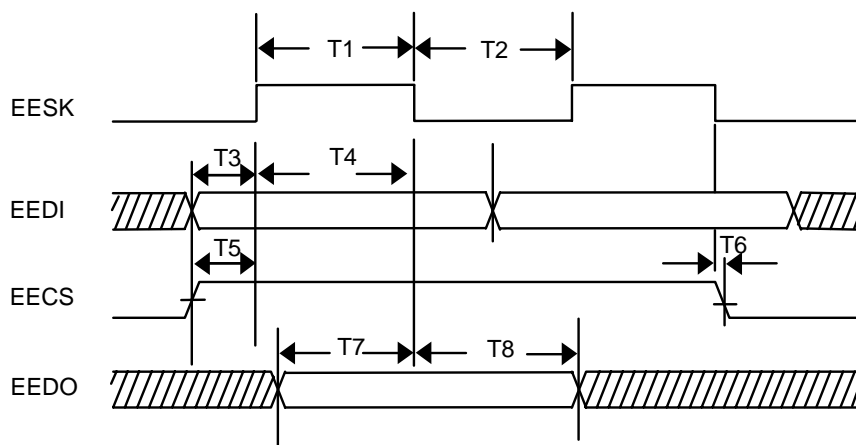
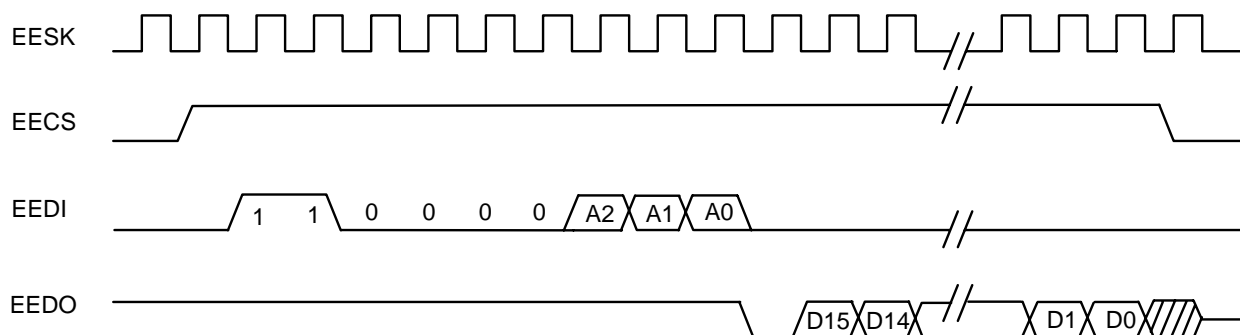

Symbol	Parameter	Min.	Typ.	Max.	Unit
T1	EESK high width		3.2		μs
T2	EESK low width		3.2		μs
T3	EEDI setup to EESK rising edge	3.0			μs
T4	EEDI hold from EESK rising edge	3.0			μs
T5	EECS goes high to EESK rising edge	3.0			μs
T6	EECS goes low from EESK falling edge		0		ns
T7	EEDO setup to EESK falling edge	20			ns
T8	EEDO hold from EESK falling edge	10			ns

10.4 GPIO Interface

Symbol	Parameter	Min.	Typ.	Max.	Unit
V_{ih}	Input high voltage	2.0			V
V_{il}	Input low voltage			0.8	V
V_{oh}	Output high voltage	0.9Vcc			V
V_{ol}	Output low voltage			0.1Vcc	V
I_{ih}	Input high leakage current			50	μ A
I_{il}	Input low leakage current			-10	μ A

10.5 USB interface

Symbol	Parameter	Min.	Typ.	Max.	Unit
T_{fr}	Rise Time	9.6	12	14.4	ns
T_{ff}	Fall Time	12.8	16	19.2	ns

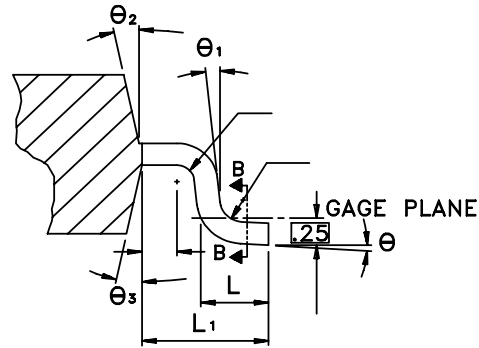
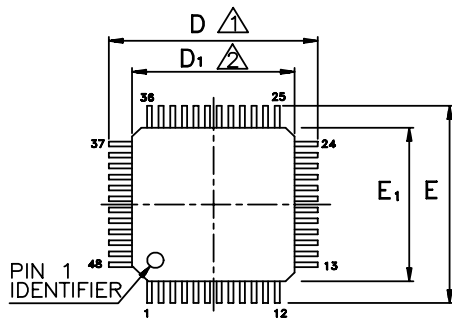
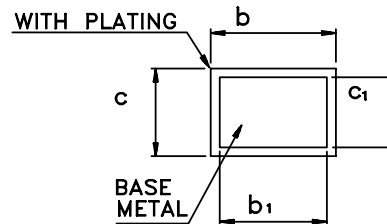
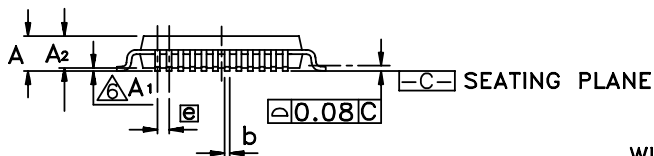
SECTION A-A

SECTION B-B

Symbol	Dimension in inch			Dimension in mm		
	Min	Nom	Max	Min	Nom	Max
A	—	—	0.067	—	—	1.70
A ₁	0.000	0.004	0.008	0.00	0.1	0.20
A ₂	0.051	0.055	0.059	1.30	1.40	1.50
b	0.006	0.009	0.011	0.15	0.22	0.29
b ₁	0.006	0.008	0.010	0.15	0.20	0.25
c	0.004	—	0.008	0.09	—	0.20
c ₁	0.004	—	0.006	0.09	—	0.16
D	0.354 BSC			9.00 BSC		
D ₁	0.276 BSC			7.00 BSC		
E	0.354 BSC			9.00 BSC		
E ₁	0.276 BSC			7.00 BSC		
[e]	0.020 BSC			0.50 BSC		
L	0.016	0.024	0.031	0.40	0.60	0.80
L ₁	0.039 REF			1.00 REF		
θ	0°	3.5°	9°	0°	3.5°	9°
θ ₁	0°	—	—	0°	—	—
θ ₂	12° TYP			12° TYP		
θ ₃	12° TYP			12° TYP		

- Note:
- To be determined at seating plane -c-
 - Dimensions D₁ and E₁ do not include mold protrusion. D₁ and E₁ are maximum plastic body size dimensions including mold mismatch.
 - Dimension b does not include dambar protrusion. Dambar can not be located on the lower radius of the foot.
 - Exact shape of each corner is optional.
 - These dimensions apply to the flat section of the lead between 0.10 mm and 0.25 mm from the lead tip.
 - A₁ is defined as the distance from the seating plane to the lowest point of the package body.
 - Controlling dimension : millimeter.
 - Reference document : JEDEC MS-026 , BBC

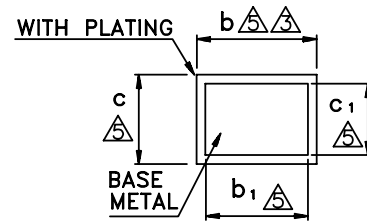
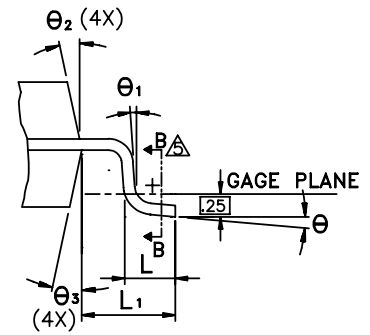
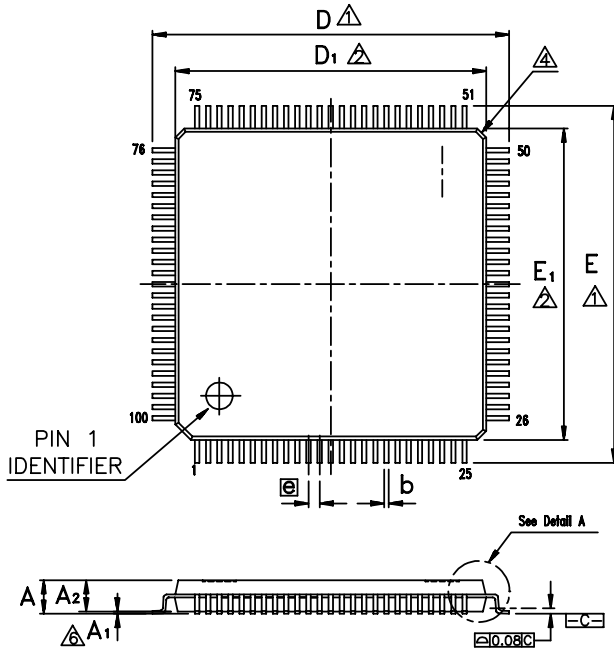
TITLE : 48LD LQFP (7x7x1.4mm)		
PACKAGE OUTLINE DRAWING , FOOTPRINT 2.0mm		
LEADFRAME MATERIAL:		
APPROVE	DOC. NO.	
	VERSION	1
CHECK	PAGE	OF
	DWG NO	SS048 - P1
	DATE	MAR. 25.1997
REALTEK SEMI-CONDUCTOR CO.,LTD		



SECTION B-B

Note:

- To be determined at seating plane -c-
- Dimensions D₁ and E₁ do not include mold protrusion.
D₁ and E₁ are maximum plastic body size dimensions including mold mismatch.
- Dimension b does not include dambar protrusion.
Dambar can not be located on the lower radius of the foot.
- Exact shape of each corner is optional.
- These dimensions apply to the flat section of the lead between 0.10 mm and 0.25 mm from the lead tip.
- A₁ is defined as the distance from the seating plane to the lowest point of the package body.
- Controlling dimension : millimeter.
- Reference document : JEDEC MS-026 , BED.

Symbol	Dimension in inch			Dimension in mm		
	Min	Nom	Max	Min	Nom	Max
A	—	—	0.067	—	—	1.70
A ₁	0.000	0.004	0.008	0.00	0.1	0.20
A ₂	0.051	0.055	0.059	1.30	1.40	1.50
B	0.006	0.009	0.011	0.15	0.22	0.29
B ₁	0.006	0.008	0.010	0.15	0.20	0.25
C	0.004	—	0.008	0.09	—	0.20
C ₁	0.004	—	0.006	0.09	—	0.16
D	0.630 BSC			16.00 BSC		
D ₁	0.551 BSC			14.00 BSC		
E	0.630 BSC			16.00 BSC		
E ₁	0.551 BSC			14.00 BSC		
e	0.020 BSC			0.50 BSC		
L	0.016	0.024	0.031	0.40	0.60	0.80
L ₁	0.039 REF			1.00 REF		
θ	0°	3.5°	9°	0°	3.5°	9°
θ ₁	0°	—	—	0°	—	—
θ ₂	12° TYP			12° TYP		
θ ₃	12° TYP			12° TYP		

TITLE : 100LD LQFP (14x14x1.4mm) PACKAGE OUTLINE DRAWING , FOOTPRINT 2.0mm			
LEADFRAME MATERIAL:			
APPROVE		DOC. NO.	
		VERSION	1
		PAGE	OF
CHECK		DWG NO.	LQ100 - P1
		DATE	APR. 28.1997
REALTEK SEMI-CONDUCTOR CO.,LTD			