

## LCD Segment Drivers

# Standard Segment Drivers



BU9795AKV/FV/GUW, BU9794AKV, BU97950FUV/KS2

No.11044EBT06

## ●Description

ROHM standard function segment driver series achieve "Ultra-Low power consumption". Also these drivers need not external components. And this driver series is very simple that only has segment driver function. So, these driver series are very suitable to add in LCD display function for various applications.

## ●Features (BU9795AKV/FV/GUW, BU9794AKV)

- 1) 3wire serial interface
- 2) Integrated RAM for display data (DDRAM)
- 3) Power supply circuit for LCD driving
  - 1/2, 1/3Bias selectable
  - 1/4Duty
  - Integrated Buffer AMP
- 4) Integrated Oscillation circuit
- 5) Integrated Power-on Reset circuit
- 6) No external components
- 7) Support blink function
- 8) Support standby mode
- 9) Low voltage / Ultra low power consumption design
- 10) Support unity voltage supply (BU9795AKV/FV/GUW)
- 11) Support Independent power supply circuit for LCD driving (BU9794AKV)

## ●Features (BU97950FUV/KS2)

- 1) 2wire serial interface
- 2) Integrated RAM for display data (DDRAM)
- 3) Integrated Power supply circuit for LCD driving
  - 1/4 Bias 1/8 Duty
  - Integrated Buffer AMP
- 4) Integrated Oscillation circuit
- 5) Integrated Power-on Reset circuit
- 6) No external components
- 7) Support standby mode
- 8) Low voltage / Ultra low power consumption design
- 9) Integrated Electrical volume register (EVR) function
- 10) Support Register Read function
- 11) Support Independent power supply circuit for LCD driving

## ●Applications

Telephone, FAX, Portable equipment (POS, ECR, PDA etc.),  
DSC, Digital video camera, Home electrical appliance, Meter equipment, Healthcare equipment etc.

## ●Line up matrix

Parameter	BU9795A			BU9794AKV	BU97950	
	KV	FV	GUW		FUV	KS2
Segment output	35	27	31	50	35	35
Common output	4	4	4	4	8	8
Total display dot number	140	108	124	200	280	280
Adjustable contrast function	-	-	-	-	Yes	Yes
Support split voltage supply	-	-	-	Yes	Yes	Yes
Interface	3wire	3wire	3wire	3wire	2wire	2wire
Package	VQFP48C	SSOP-B40	VBGA48W040	VQFP64	TSSOP-C48V	SQFP-T52

## ●Absolute maximum ratings (VSS=0V)

Parameter	BU9795AKV /FV/GUW	BU9794AKV	BU97950FUV /KS2	Unit	Remarks
Power Supply Voltage 1 (VDD)	-0.5~+7.0			V	Power supply
Power Supply Voltage 2 (VLCD)	-0.5~VDD	-0.5~+7.0	-0.5~+7.0	V	LCD drive Voltage
Allowable Loss (Pd)	0.6 <sup>*1</sup> 0.7 <sup>*2</sup> 0.27 <sup>*3</sup>	0.75 <sup>*4</sup>	0.64 <sup>*5</sup> 0.85 <sup>*6</sup>	W	Allowable loss at package only
Input Voltage Range (VIN)	-0.5~VDD+0.5			V	
Operational Temperature Range (Topr)	-40~+85			°C	
Storage Temperature Range (Tstg)	-55~+125			°C	

\*1 When use more than Ta=25°C, subtract 6.0mW per degree (BU9795AKV)

\*2 When use more than Ta=25°C, subtract 7.0mW per degree (BU9795AFV)

\*3 When use more than Ta=25°C, subtract 2.7mW per degree (BU9795AGUW)

\*4 When use more than Ta=25°C, subtract 7.5mW per degree (BU9794AKV)

\*5 When use more than Ta=25°C, subtract 6.4mW per degree (BU97950FUV)

\*6 When use more than Ta=25°C, subtract 8.5mW per degree (BU97950FUV)

## ●Recommend operating conditions (Ta=-40~85°C, VSS=0V)

Parameter	BU9795AKV /FV/GUW <sup>*7</sup>			BU9794AKV			BU97950KV/KS2			Unit	Remarks
	MIN	TYP	MAX	MIN	TYP	MAX	MIN	TYP	MAX		
Power Supply Voltage 1 (VDD)	2.5	-	5.5	2.5	-	5.5	2.5	-	5.5	V	Power supply
Power Supply Voltage 2 (VLCD)	0	-	VDD -2.4	2.5	-	5.5	2.5	-	5.5	V	LCD drive Voltage

\*7 Please use VDD-VLCD ≥ 2.4V condition.

●Electrical characteristics

<BU9795AKV/FV/GUW>

DC Characteristics (VDD=2.5~5.5V, VSS=0V, Ta=-40~85°C, unless otherwise specified)

Parameter	Symbol	Limits			Unit	Condition
		MIN	TYP	MAX		
"H" level input voltage	VIH	0.7VDD	-	VDD	V	SD, SCL, CSB
"L" level input voltage	VIL	VSS	-	0.3VDD	V	SD, SCL, CSB
"H" level input current	I <sub>IH</sub>	-	-	1	μA	SD, SCL, CSB
"L" level input current	I <sub>IL</sub>	-1	-	-	μA	SD, SCL, CSB
LCD Driver on resistance	SEG	RON	-	3.5	-	kΩ I <sub>load</sub> =±10μA
	COM	RON	-	3.5	-	
VLCD supply voltage	VLCD	0	-	VDD-2.4	V	VDD-VLCD ≥ 2.4V
Standby current	I <sub>st</sub>	-	-	5	μA	Display off, Oscillator off
Power consumption 1	IDD1	-	12.5	30	μA	VDD=3.3[V], Ta=25°C, Power save mode1, FR=70Hz 1/3 bias, Frame inverse
Power consumption 2	IDD2	-	20	40	μA	VDD=3.3[V], Ta=25°C, Normal mode, FR=80Hz 1/3 bias, Line inverse

Oscillation Characteristics (VDD=2.5~5.5V, VSS=0V, Ta=-40~85°C)

Parameter	Symbol	Limits			Unit	Condition
		MIN	TYP	MAX		
Frame frequency	fCLK	56	80	104	Hz	FR = 80Hz setting
Frame frequency1	fCLK1	70	80	90	Hz	VDD=3.5V, 25°C

MPU interface Characteristics(VDD=2.5V~5.5V, VSS=0V, Ta=-40~85°C)

Parameter	Symbol	Limits			Unit	Condition
		MIN	TYP	MAX		
Input rise time	t <sub>r</sub>	-	-	80	ns	
Input fall time	t <sub>f</sub>	-	-	80	ns	
SCL cycle time	t <sub>SCYC</sub>	400	-	-	ns	
"H" SCL pulse width	t <sub>SHW</sub>	100	-	-	ns	
"L" SCL pulse width	t <sub>SLW</sub>	100	-	-	ns	
SD setup time	t <sub>SDS</sub>	20	-	-	ns	
SD hold time	t <sub>SDH</sub>	50	-	-	ns	
CSB setup time	t <sub>CSS</sub>	50	-	-	ns	
CSB hold time	t <sub>CSH</sub>	50	-	-	ns	
"H" CSB pulse width	t <sub>CHW</sub>	50	-	-	ns	

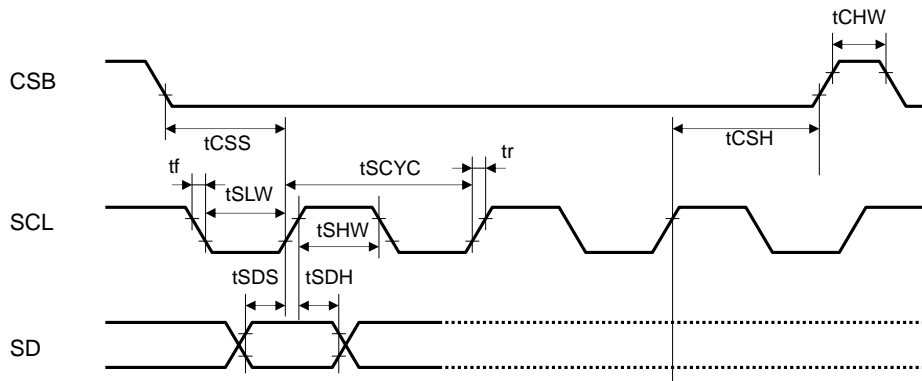

Fig.1 Interface Timing (BU9795AKV/FV/GUW)

<BU9794AKV>

DC Characteristics (VDD=2.5~5.5V, VLCD=2.5~5.5V, VSS=0V, Ta=-40~85°C, unless otherwise specified)

Parameter	Symbol	Limits			Unit	Condition
		MIN	TYP	MAX		
"H" level input voltage	VIH	0.8VDD	-	VDD	V	SD,SCL,CSB
"L" level input voltage	VIL	VSS	-	0.2VDD	V	SD,SCL,CSB
"H" level input current	IIH	-	-	1	μA	SD,SCL,CSB
"L" level input current	IIL	-1	-	-	μA	SD,SCL,CSB
LCD Driver on resistance	SEG	RON	-	3.5	-	kΩ
	COM	RON	-	3.5	-	kΩ
Standby current	Ist	-	-	5	μA	Display off, Oscillation off
Power consumption 1	IDD	-	5	15	μA	VDD=3.3V, VLCD=5V, Ta=25°C Power save mode1, FR=70Hz 1/3 bias, Frame inverse
Power consumption 2	ILCD	-	10	20	μA	VDD=3.3V, VLCD=5V, Ta=25°C Power save mode1, FR=70Hz 1/3 bias, Frame inverse

Oscillation Characteristics (VDD=2.5~5.5V, VLCD=2.5~5.5V, VSS=0V, Ta=-40~85°C, unless otherwise specified)

Parameter	Symbol	Limits			Unit	Condition
		MIN	TYP	MAX		
Frame frequency	fCLK	68	80	92	Hz	FR = 80Hz setting, VDD=3.3V

MPU interface Characteristics (VDD=2.5~5.5V, VLCD=2.5~5.5V, VSS=0V, Ta=-40~85°C, unless otherwise specified)

Parameter	Symbol	Limits			Unit	Condition
		MIN.	TYP.	MAX.		
Input rise time	tr	-	-	80	ns	
Input fall time	tf	-	-	80	ns	
SCL cycle time	tSCYC	400	-	-	ns	
"H" SCL pulse width	tSHW	100	-	-	ns	
"L" SCL pulse width	tSLW	100	-	-	ns	
SD setup time	tSDS	20	-	-	ns	
SD hold time	tSDH	50	-	-	ns	
CSB setup time	tCSS	50	-	-	ns	
CSB hold time	tCSH	50	-	-	ns	
"H" CSB pulse time	tCHW	50	-	-	ns	

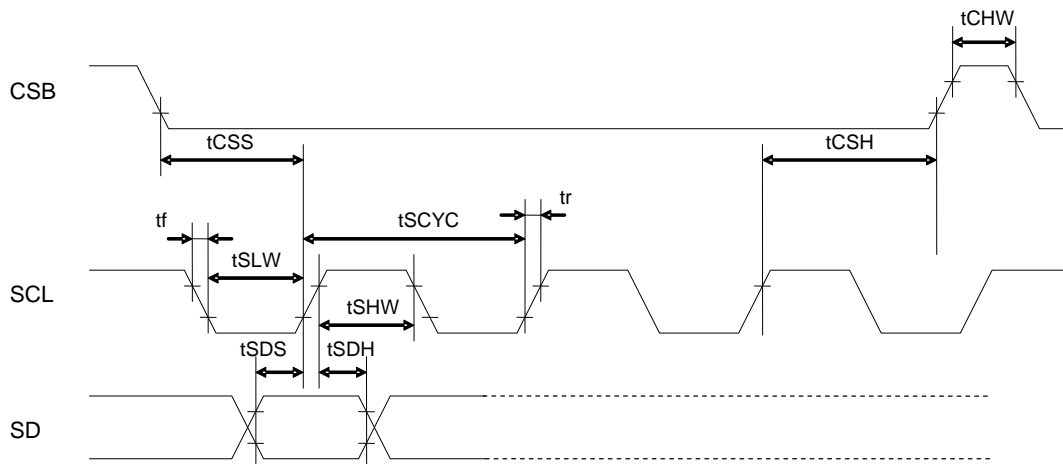

Fig.2 Interface Timing (BU9794AKV)

<BU97950FUV/KS2>

DC Characteristics (VDD=2.5~5.5V, VLCD=2.5~5.5V, VSS=0V, Ta=-40~85 °C, unless otherwise specified)

Parameter	Symbol	Limits			Unit	Conditions
		MIN	TYP	MAX		
“H” level input voltage	VIH	0.7VDD	-	VDD	V	SDA,SCL
“L” level input voltage	VIL	VSS	-	0.3VDD	V	SDA,SCL
“H” level input current	IIH	-	-	1	μA	SDA,SCL
“L” level input current	IIL	-1	-	-	μA	SDA,SCL
LCD Driver on resistance	SEG	RON	-	3.5	-	kΩ Iload=±10μA
	COM	RON	-	3.5	-	
Standby current	Ist	-	-	5	μA	Display off, Oscillation off
Power consumption 1	IDD	-	2.5	15	μA	VDD=3.3V, VLCD=5V, Ta=25 °C Power save mode1, FR=80Hz 1/4 bias, Frame inverse
Power consumption 2	ILCD	-	10	20	μA	VDD=3.3V, VLCD=5V, Ta=25 °C Power save mode1, FR=80Hz 1/4 bias, Frame inverse

Oscillation Characteristics (VDD=2.5~5.5V, VSS=0V, Ta=-40~85°C, unless otherwise specified)

Parameter	Symbol	Limits			Unit	Condition
		MIN	TYP	MAX		
Frame frequency	fCLK	56	80	104	Hz	Power save mode FR = Normal mode

MPU interface Characteristics (VDD=2.5~5.5V, VLCD=0V, VSS=0V, Ta=-40~85°C, unless otherwise specified)

Parameter	Symbol	Limits			Unit	Condition
		MIN.	TYP.	MAX.		
Input rise time	tr	-	-	0.3	μs	
Input fall time	tf	-	-	0.3	μs	
SCL cycle time	tSCYC	2.5	-	-	μs	
“H” SCL pulse width	tSHW	0.6	-	-	μs	
“L” SCL pulse width	tSLW	1.3	-	-	μs	
SDA setup time	tSDS	100	-	-	ns	
SDA hold time	tSDH	100	-	-	ns	
Bus free time	tBUF	1.3	-	-	μs	
START condition hold time	tHD;STA	0.6	-	-	μs	
START condition setup time	tSU;STA	0.6	-	-	μs	
STOP condition setup time	tSU;STO	0.6	-	-	μs	

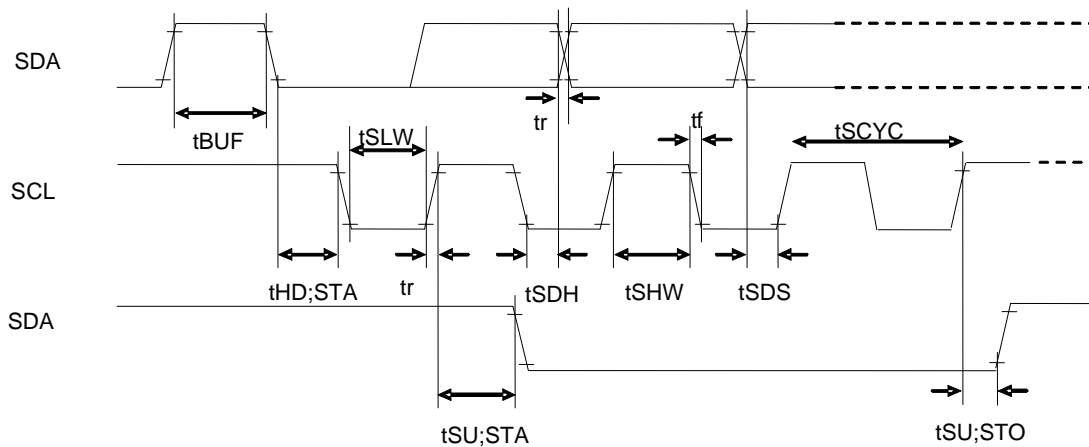

Fig.3 interface timing (BU97950FUV)

●Block Diagram / Pin Arrangement / Terminal Description

<BU9795AKV>

●Block Diagram

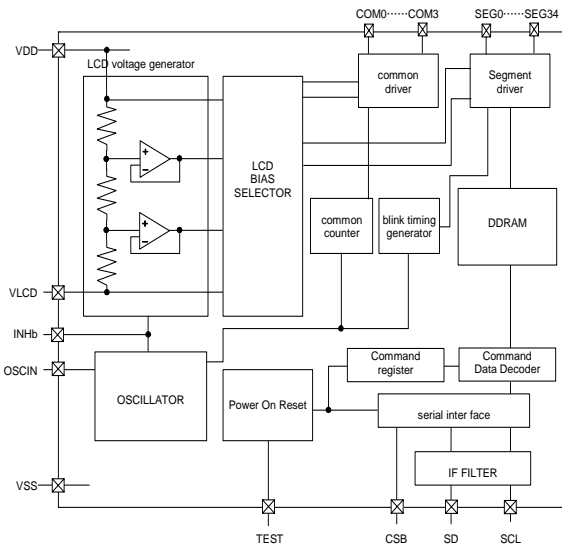

Fig.4 Block Diagram (BU9795AKV)

●Pin Arrangement

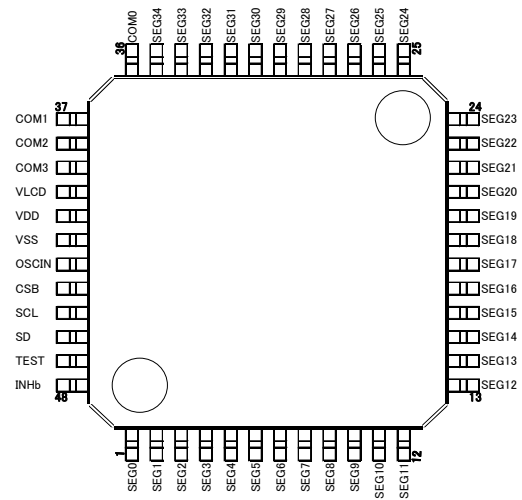

Fig.5 Pin Arrangement (BU9795AKV)

●Terminal Description

Terminal	Terminal No.	I/O	Function
INHb	48	I	Input terminal for turn off display H: turn on display L: turn off display
TEST	47	I	Test input (ROHM use only) Must be connect to VSS
OSCIN	43	I	External clock input Ext clock and Int clock can be changed by command. Must be connect to VSS when use internal oscillation circuit.
SD	46	I	serial data input
SCL	45	I	serial data transfer clock
CSB	44	I	Chip select : "L" active
VSS	42		GND
VDD	41		Power supply
VLCD	40		Power supply for LCD driving
SEG0-34	1-35	O	SEGMENT output for LCD driving
COM0-3	36-39	O	COMMON output for LCD driving

<BU9795AFV>  
**●Block Diagram**

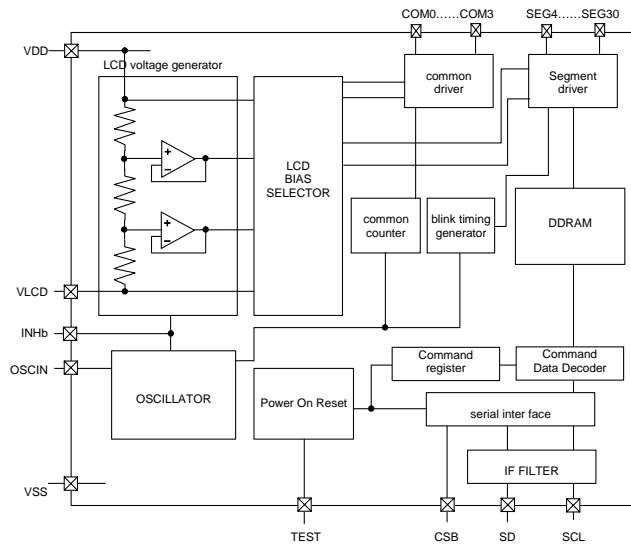

Fig.6 Block Diagram (BU9795AFV)

**●Pin Arrangement**

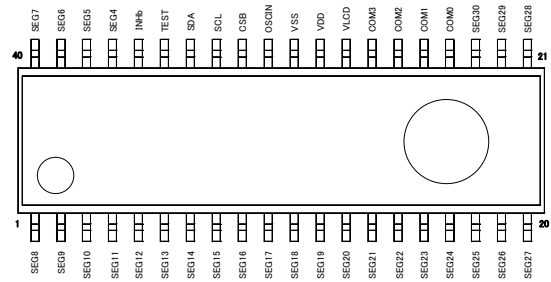

Fig.7 Pin Arrangement (BU9795AFV)

**●Terminal Description**

Terminal	Terminal No.	I/O	Function
INHb	36	I	Input terminal for turn off display H: turn on display L: turn off display
TEST	35	I	Test input (ROHM use only) Must be connect to VSS
OSCIN	31	I	External clock input Ex clock and Int clock can be changed by command. Must be connect to VSS when use internal oscillation circuit.
SD	34	I	serial data input
SCL	33	I	serial data transfer clock
CSB	32	I	Chip select : "L" active
VSS	30		GND
VDD	29		Power supply
VLCD	28	I	Power supply for LCD driving
SEG4-30	1-23, 37-40	O	SEGMENT output for LCD driving
COM0-3	24-27	O	COMMON output for LCD driving

<BU9795AGUW>

●Block Diagram

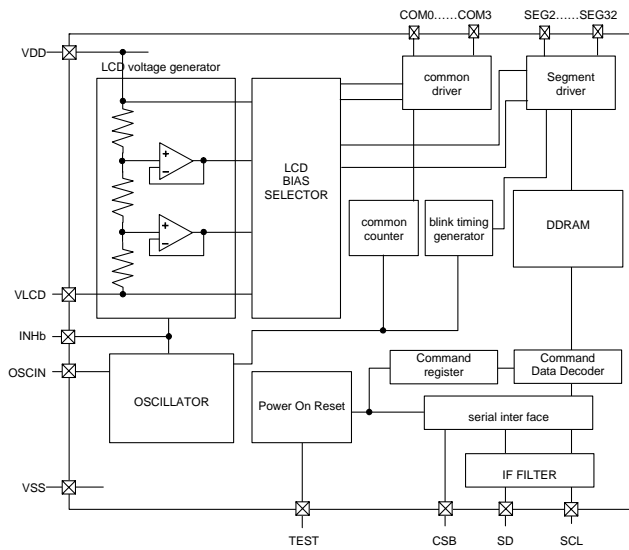

Fig.8 Block Diagram (BU9795AGUW)

●Pin Arrangement

	1	2	3	4	5	6	7
G	(NC)	SEG13	SEG15	SEG18	SEG20	SEG22	(NC)
F	SEG11	SEG12	SEG16	SEG17	SEG21	SEG23	SEG24
E	SEG9	SEG10	SEG14	SEG19	SEG25	SEG27	SEG26
D	SEG7	SEG6	SEG8	SEG5	SEG30	SEG28	SEG29
C	SEG4	SEG3	SEG2	CSB	COM3	SEG32	SEG31
B	X	INHb	SD	VSS	VDD	COM1	COM0
A	(NC)	TEST2	SCL	OSCIN	VLCD	COM2	(NC)

Fig.9 Pin Arrangement (BU9795AGUW)

●Terminal Description

Terminal	I/O	Function
INHb	I	Input terminal for turn off display H: turn on display L: turn off display
TEST	I	Test input (ROHM use only) Must be connect to VSS
OSCIN	I	External clock input Ex clock and Int clock can be changed by command. Must be connect to VSS when use internal oscillation circuit.
SD	I	serial data input
SCL	I	serial data transfer clock
CSB	I	Chip select : "L" active
VSS		GND
VDD		Power supply
VLCD	I	Power supply for LCD driving
SEG2-32	O	SEGMENT output for LCD driving
COM0-3	O	COMMON output for LCD driving

(Caution) About terminal number, please refer to above pin arrangement



<BU9794AKV>  
 ●Block Diagram

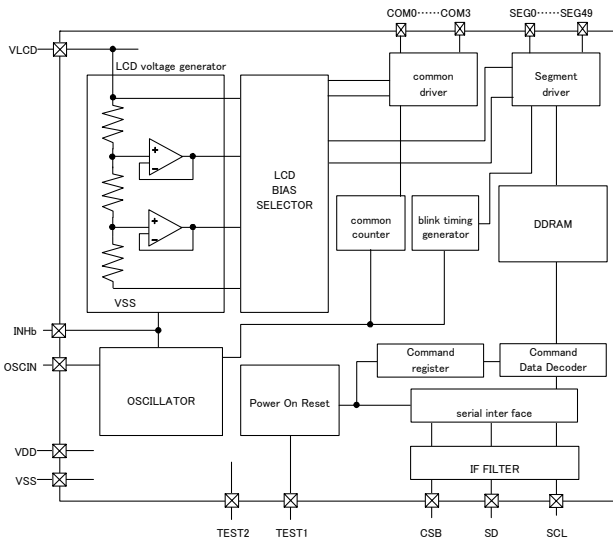

Fig.10 Block Diagram (BU9794AKV)

●Pin Arrangement

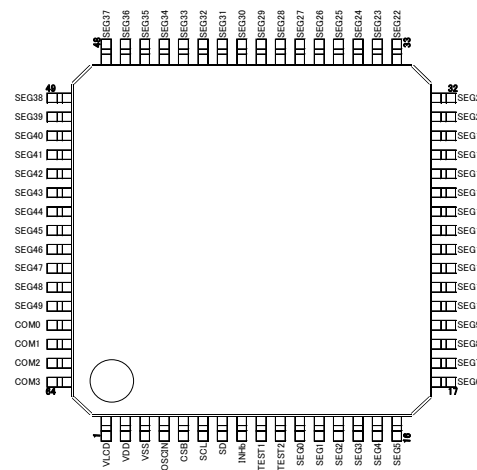

Fig.11 Pin Arrangement (BU9794AKV)

●Terminal Description

Terminal	Terminal No.	I/O	Function
INHb	8	I	Input terminal for turn off display H: turn on display, L: turn off display
TEST1	9	I	Test input (ROHM use only) Must be connect to VSS
TEST2	10	I	Test input (ROHM use only) Must be connect to VSS
OSCIN	4	I	External clock input Ex clock and Int clock can be changed by command. Must be connect to VSS when use internal oscillation circuit.
SD	7	I	serial data input
SCL	6	I	serial data transfer clock
CSB	5	I	Chip select : "L" active
VSS	3		GND
VDD	2		Power supply
VLCD	1		Power supply for LCD driving
SEG0-49	11-60	O	SEGMENT output for LCD driving
COM0-3	61-64	O	COMMON output for LCD driving

<BU97950FUV>

●Block Diagram

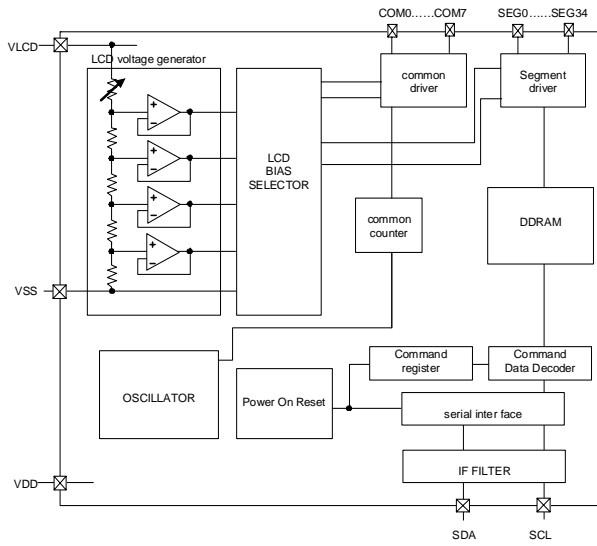

Fig.12 Block Diagram (BU97950FUV)

●Pin Arrangement

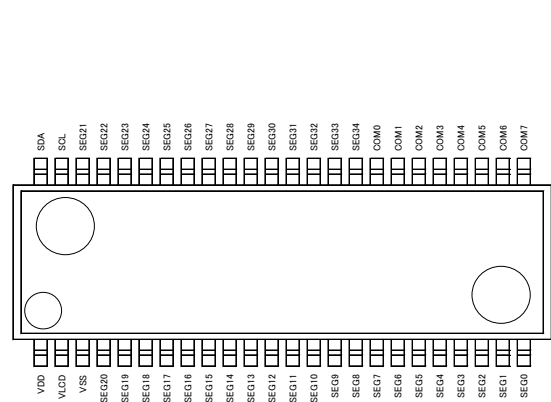

Fig.13 Pin Arrangement (BU97950FUV)

●Terminal Description

Terminal	Terminal No.	I/O	Function
SDA	48	I/O	serial data input register read data output port
SCL	47	I	serial data transfer clock
VSS	3	I	GND
VDD	1	I	Power supply
VLCD	2	I	Power supply for LCD driving
SEG0-35	4-24 33-46	O	SEGMENT output for LCD driving
COM0-7	25-32	O	COMMON output for LCD driving

<BU97950KS2>

●Block Diagram

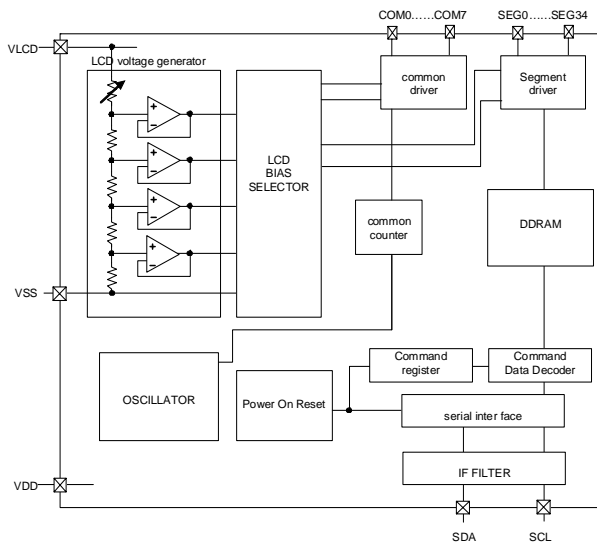

Fig.14 Block Diagram (BU97950KS2)

●Pin Arrangement

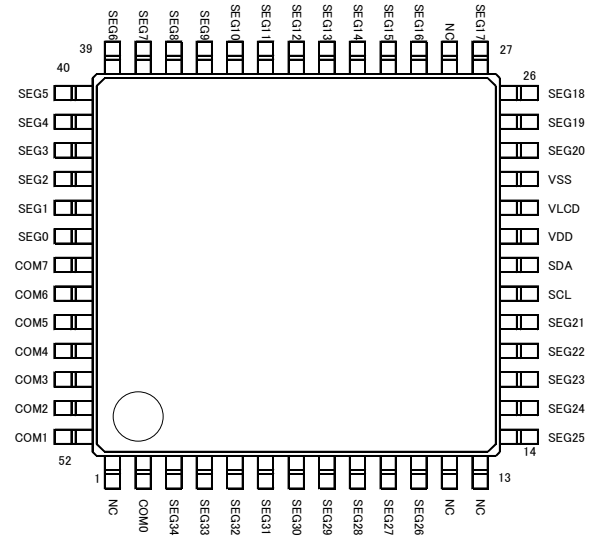

Fig.15 Pin Arrangement (BU97950KS2)

●Terminal Description

Terminal	Terminal No.	I/O	Function
SDA	20	I/O	serial data input
SCL	19	I	serial data transfer clock
VSS	23	I	GND
VDD	21	I	Power supply
VLCD	22	I	Power supply for LCD driving
SEG0-35	3-11 24-27 29-45	O	SEGMENT output for LCD driving
COM0-7	2 46-52	O	COMMON output for LCD driving
NC	1,12,13,28	-	No connected

●IO Equivalent Circuit

<BU9795AKV/FV/GUW>

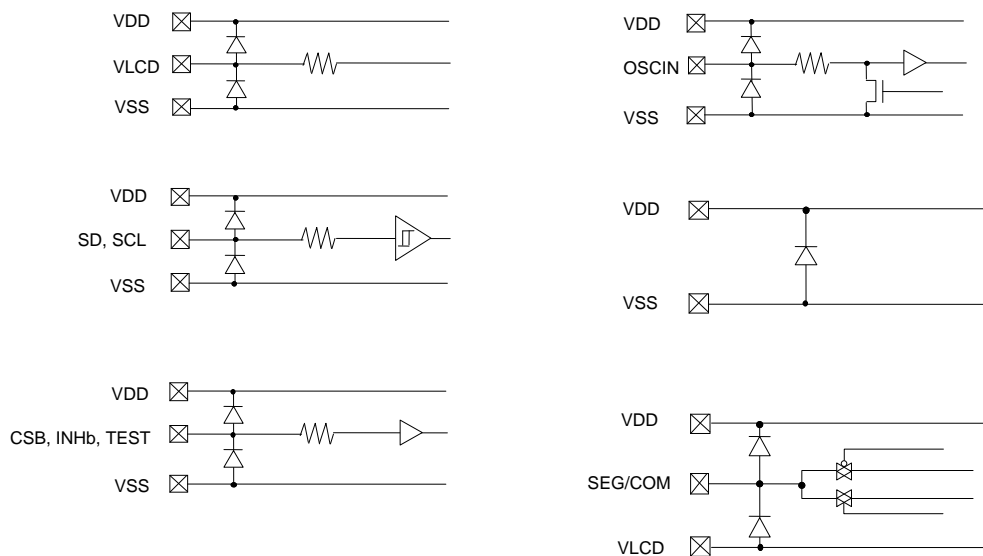

Fig.16 I/O equivalent circuit (BU9795AKV/FV/GUW)

<BU9794AKV>

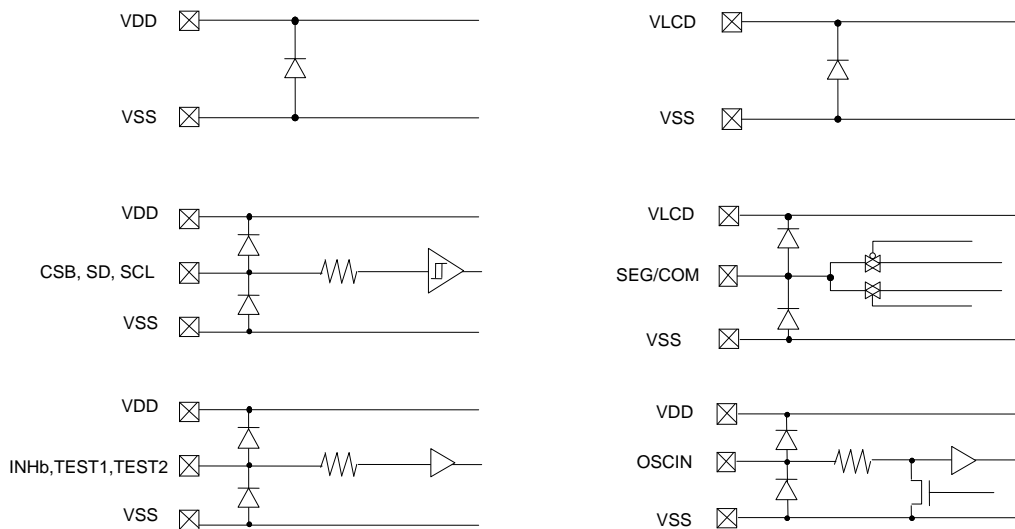

Fig.17 I/O equivalent circuit (BU9794AKV)

<BU97950FUV>

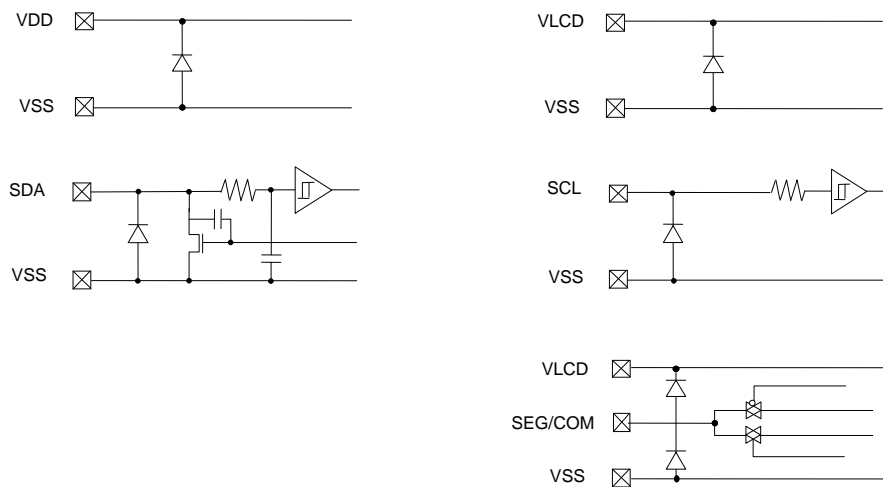
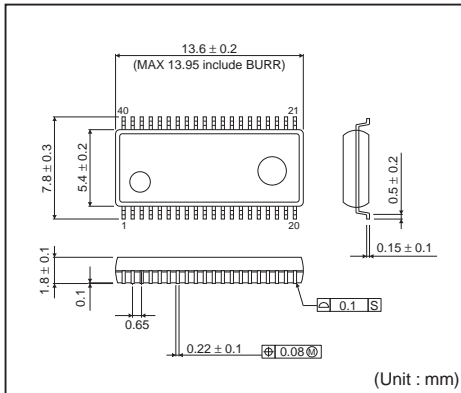

Fig.18 I/O equivalent circuit (BU97950FUV/KS2)

●Ordering part number

B	U	9	7	9	4	A	K	V	-	E	2	
Part No.		Part No.					Package		Packaging and forming specification			
		BU9794A BU9795A BU97950					FV : SSOP-B40 GUW : VBGA048W040 KV : VQFP48C KV : VQFP64 FUV : TSSOP-C48V KS2 : SQFP-T52		E2: Embossed tape and reel			

SSOP-B40



<Tape and Reel information>

Tape	Embossed carrier tape
Quantity	2000pcs
Direction of feed	E2 ( The direction is the 1pin of product is at the upper left when you hold reel on the left hand and you pull out the tape on the right hand )

Reel

1pin

Direction of feed

\*Order quantity needs to be multiple of the minimum quantity.

VBGA048W040

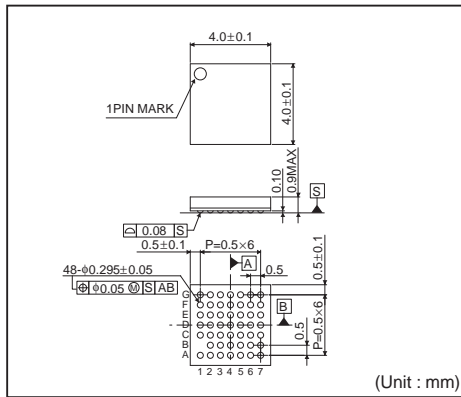

<Tape and Reel information>

Tape	Embossed carrier tape (with dry pack)
Quantity	2500pcs
Direction of feed	E2 ( The direction is the 1pin of product is at the upper left when you hold reel on the left hand and you pull out the tape on the right hand )

Reel

1pin

Direction of feed

\*Order quantity needs to be multiple of the minimum quantity.

TSSOP-C48V

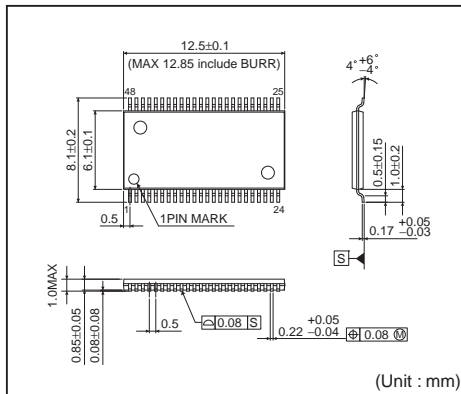

<Tape and Reel information>

Tape	Embossed carrier tape (with dry pack)
Quantity	2000pcs
Direction of feed	E2 ( The direction is the 1pin of product is at the upper left when you hold reel on the left hand and you pull out the tape on the right hand )

Reel

1pin

Direction of feed

\*Order quantity needs to be multiple of the minimum quantity.

**VQFP48C**

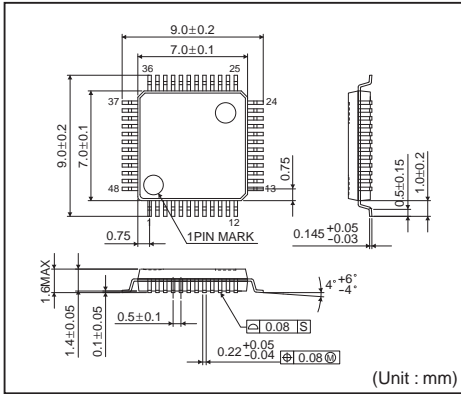

<Tape and Reel information>

Tape	Embossed carrier tape
Quantity	1500pcs
Direction of feed	E2 ( The direction is the 1pin of product is at the upper left when you hold ) reel on the left hand and you pull out the tape on the right hand

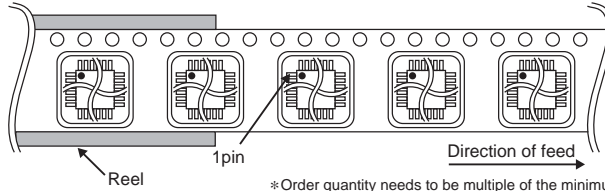

\*Order quantity needs to be multiple of the minimum quantity.

**VQFP64**

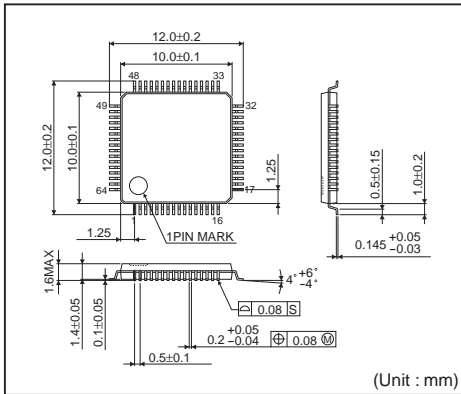

<Tape and Reel information>

Tape	Embossed carrier tape (with dry pack)
Quantity	1000pcs
Direction of feed	E2 ( The direction is the 1pin of product is at the upper left when you hold ) reel on the left hand and you pull out the tape on the right hand

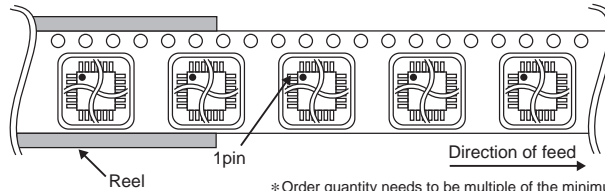

\*Order quantity needs to be multiple of the minimum quantity.

**SQFP-T52**

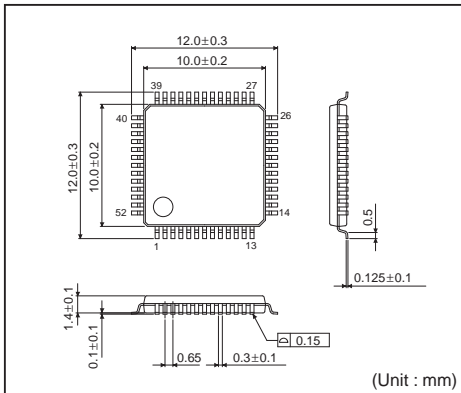

<Tape and Reel information>

Container	Tray (with dry pack)
Quantity	1000pcs
Direction of feed	Direction of product is fixed in a tray

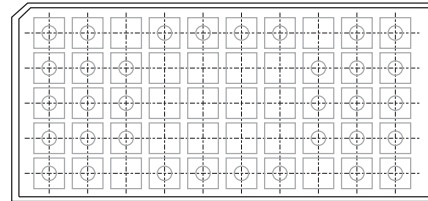
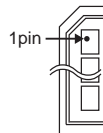

\*Order quantity needs to be multiple of the minimum quantity.

## Notes

No copying or reproduction of this document, in part or in whole, is permitted without the consent of ROHM Co.,Ltd.

The content specified herein is subject to change for improvement without notice.

The content specified herein is for the purpose of introducing ROHM's products (hereinafter "Products"). If you wish to use any such Product, please be sure to refer to the specifications, which can be obtained from ROHM upon request.

Examples of application circuits, circuit constants and any other information contained herein illustrate the standard usage and operations of the Products. The peripheral conditions must be taken into account when designing circuits for mass production.

Great care was taken in ensuring the accuracy of the information specified in this document. However, should you incur any damage arising from any inaccuracy or misprint of such information, ROHM shall bear no responsibility for such damage.

The technical information specified herein is intended only to show the typical functions of and examples of application circuits for the Products. ROHM does not grant you, explicitly or implicitly, any license to use or exercise intellectual property or other rights held by ROHM and other parties. ROHM shall bear no responsibility whatsoever for any dispute arising from the use of such technical information.

The Products specified in this document are intended to be used with general-use electronic equipment or devices (such as audio visual equipment, office-automation equipment, communication devices, electronic appliances and amusement devices).

The Products specified in this document are not designed to be radiation tolerant.

While ROHM always makes efforts to enhance the quality and reliability of its Products, a Product may fail or malfunction for a variety of reasons.

Please be sure to implement in your equipment using the Products safety measures to guard against the possibility of physical injury, fire or any other damage caused in the event of the failure of any Product, such as derating, redundancy, fire control and fail-safe designs. ROHM shall bear no responsibility whatsoever for your use of any Product outside of the prescribed scope or not in accordance with the instruction manual.

The Products are not designed or manufactured to be used with any equipment, device or system which requires an extremely high level of reliability the failure or malfunction of which may result in a direct threat to human life or create a risk of human injury (such as a medical instrument, transportation equipment, aerospace machinery, nuclear-reactor controller, fuel-controller or other safety device). ROHM shall bear no responsibility in any way for use of any of the Products for the above special purposes. If a Product is intended to be used for any such special purpose, please contact a ROHM sales representative before purchasing.

If you intend to export or ship overseas any Product or technology specified herein that may be controlled under the Foreign Exchange and the Foreign Trade Law, you will be required to obtain a license or permit under the Law.



Thank you for your accessing to ROHM product informations.  
More detail product informations and catalogs are available, please contact us.

### ROHM Customer Support System

<http://www.rohm.com/contact/>