

SECURITY CODE

MITSUBISHI ELECTRIC CORPORATION

Spec. NAME Customer's Std. Spec.	Prepared by	K.Kurachi	R E V				
	Checked by						
	Approved by	I.Umezaki					
	DATE	8-May-2008					

HIGH VOLTAGE DIODE MODULE

- 1. **Type Number** RM1200DB-66S
- 2. **Structure** Flat base type (Insulated package, Cu base plate)
- 3. **Application & Customer** High power converters & Inverters for traction application
- 4. **Outline** See Fig. 1
- 5. **Related Specifications**

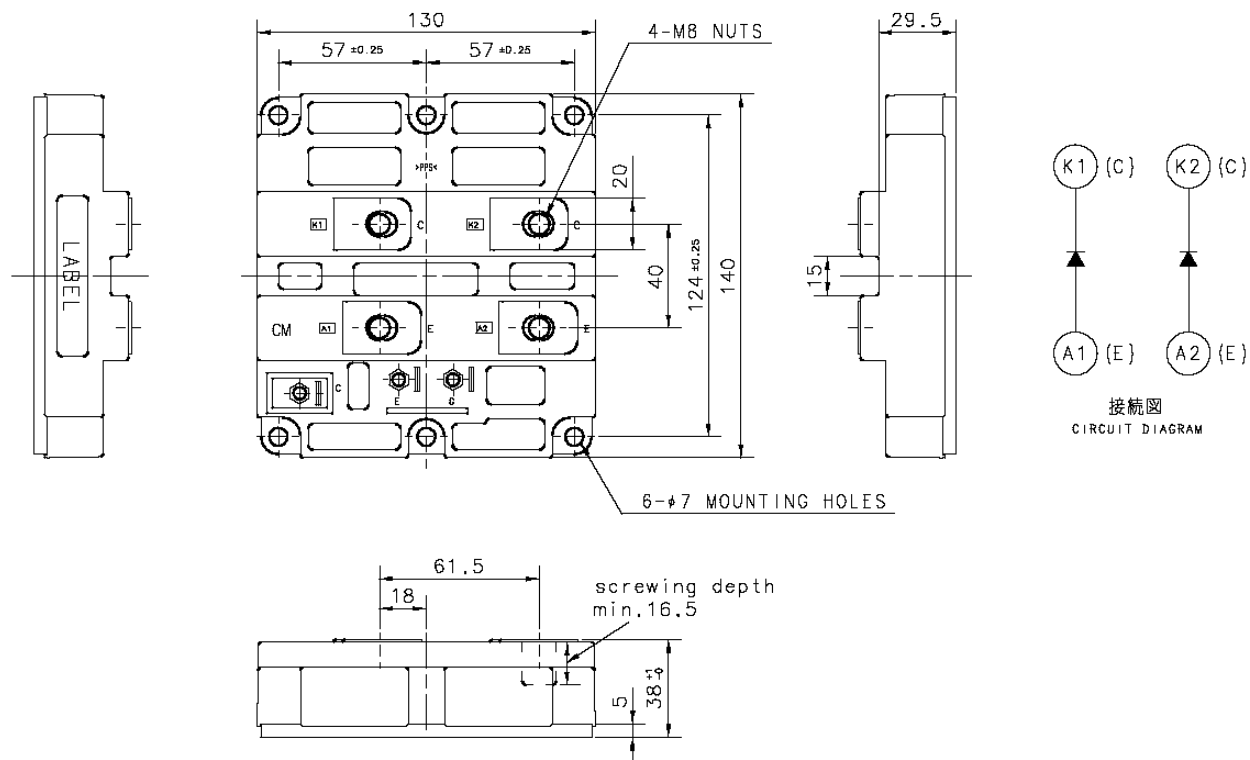

Fig. 1 - Outline drawing

HIGH VOLTAGE DIODE MODULE	HVM-2019	(HV-SETSU)	PAGE 1 / 10
---------------------------	----------	------------	----------------

6. Maximum Ratings

Item	Symbol	Conditions	Ratings	Unit
6.1 Repetitive peak reverse voltage	V_{RRM}	$T_j = 25\text{ }^\circ\text{C}$	3300	V
6.2 Non-repetitive peak reverse voltage	V_{RSM}	$T_j = 25\text{ }^\circ\text{C}$	3300	V
6.3 Reverse DC voltage	$V_{R(DC)}$	$T_j = 25\text{ }^\circ\text{C}$	2200	V
6.4 DC forward current	I_F	$T_c = 25\text{ }^\circ\text{C}$	1200	A
6.5 Surge forward current	I_{FSM}	$T_j = 25\text{ }^\circ\text{C}$ start, $t_w = 8.3\text{ ms}$ Half sign wave	9600	A
6.6 Surge current load integral	I^2t	$T_j = 25\text{ }^\circ\text{C}$ start, $t_w = 8.3\text{ ms}$ Half sign wave	384	kA^2s
6.7 Isolation voltage	V_{iso}	Charged part to the baseplate RMS sinusoidal, 60Hz 1min.	6000	V
6.8 Junction temperature	T_j	—	-40 ~ +150	$^\circ\text{C}$
6.9 Storage temperature	T_{stg}	—	-40 ~ +125	$^\circ\text{C}$
6.10 Operating temperature	T_{op}	—	-40 ~ +125	$^\circ\text{C}$
6.11 Maximum reverse recovery instantaneous power	—	$V_R \leq 2200\text{ V}$ $di/dt \leq 4800\text{ A}/\mu\text{s}$, $T_j = 125\text{ }^\circ\text{C}$ [See Fig.1, Fig.2, 12-5]	2100	kW

7. Electrical Characteristics

Item	Symbol	Conditions	Limits			Unit	
			Min.	Typ.	Max.		
7.1 Repetitive reverse current	I_{RRM}	$V_{RM} = V_{RRM}$	$T_j = 25\text{ }^\circ\text{C}$	—	—	5	mA
			$T_j = 125\text{ }^\circ\text{C}$	—	3	30	
7.2 Forward voltage	V_{FM}	$I_F = 1200\text{ A}$	$T_j = 25\text{ }^\circ\text{C}$	—	2.80	—	V
			$T_j = 125\text{ }^\circ\text{C}$	—	2.70	—	
7.3 Reverse recovery time	t_{rr}	$V_R = 1650\text{ V}$, $I_F = 1200\text{ A}$ $di/dt = -3700\text{ A}/\mu\text{s}$ $T_j = 125\text{ }^\circ\text{C}$ [See Fig.1, Fig.2]	—	0.75	—	μs	
7.4 Reverse recovery current	I_{rr}		—	1600	—	A	
7.5 Reverse recovery charge	Q_{rr}		—	850	—	μC	
7.6 Reverse recovery energy	E_{rec}		—	0.75	—	J/P	

Note 1: It doesn't include the voltage drop by Internal lead resistance.

8. Thermal Characteristics

Item	Symbol	Conditions	Limits			Unit
			Min.	Typ.	Max.	
8.1 Thermal resistance	$R_{th(j-c)R}$	Junction to case (per 1/2 module)	—	—	18.0	K/kW
8.2 Contact thermal resistance	$R_{th(c-f)}$	Case to fin (Note 2) Conductive grease applied (per 1/2 module)	—	16.0	—	K/kW

Note 2: Thermal conductivity is 1W/mK with a thickness of 100 μ m.

9. Mechanical Characteristics

Item	Symbol	Conditions	Limits			Unit
			Min.	Typ.	Max.	
9.1 Mounting torque	—	Main terminal screw : M8	7.0	—	13.0	N·m
9.2 Mounting torque	—	Mounting screw : M6	3.0	—	6.0	N·m
9.3 Mass	—	—	—	1.5	—	kg
9.4 Comparative tracking index	CTI	—	600	—	—	—
9.5 Clearance	—	—	19.5	—	—	mm
9.6 Creepage distance	—	—	32	—	—	mm
9.7 Internal inductance	$L_{A-K(int)}$	—	—	35	—	nH
9.8 Internal lead resistance	$R_{A-K(int)}$	$T_c = 25\text{ }^\circ\text{C}$	—	0.25	—	m Ω

10. Shipping Inspection Report Item ^(note 3)

Static characteristics : I_{RRM} [7.1], V_{FM} [7.2]

Dynamic characteristics : t_{rr} [7.3], Q_{rr} [7.5]

Note 3: One shipping inspection report with the above item values is submitted when modules are delivered. The test conditions are defined in bracket.

11. Test Circuit & Definition of Switching Characteristics

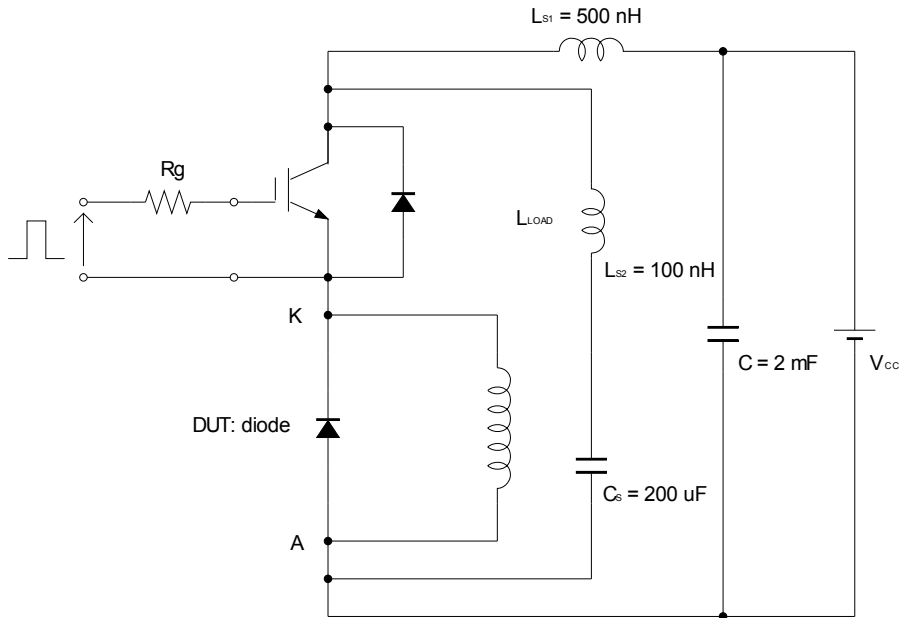
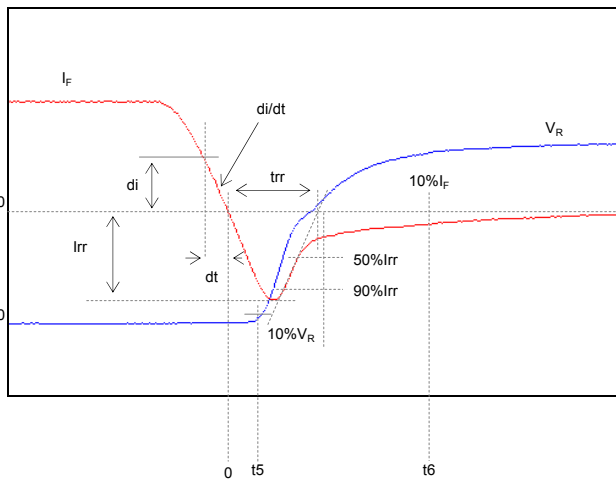

Fig. 1 – Switching test circuit

Diode part: reverse recovery



$$Q_{rr} = - \int_0^{t_6} i_f dt$$

$$E_{rec} = - \int_{t_5}^{t_6} i_f \cdot v_r dt$$

Fig. 2 – Definitions of reverse recovery charge & energy

12. Performance curves

12-1	Forward characteristics	6
12-2	Reverse recovery energy characteristics	7
12-3	Reverse recovery current characteristics.....	8
12-4	Transient thermal impedance characteristics	9
12-5	Reverse recovery safe operating area	10

12-1 Forward characteristics

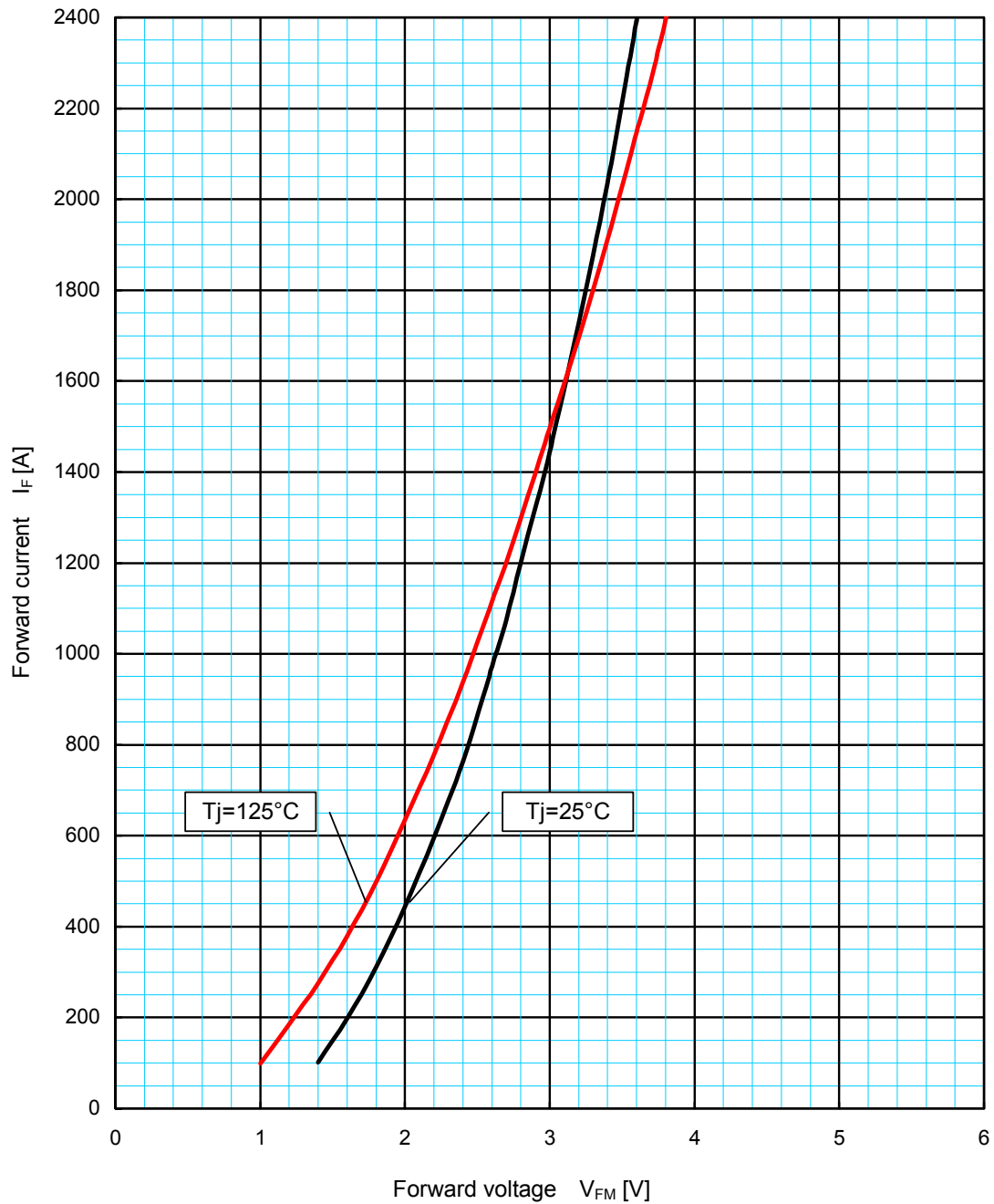

Forward voltage characteristics (typical)

12-2 Reverse recovery energy characteristics

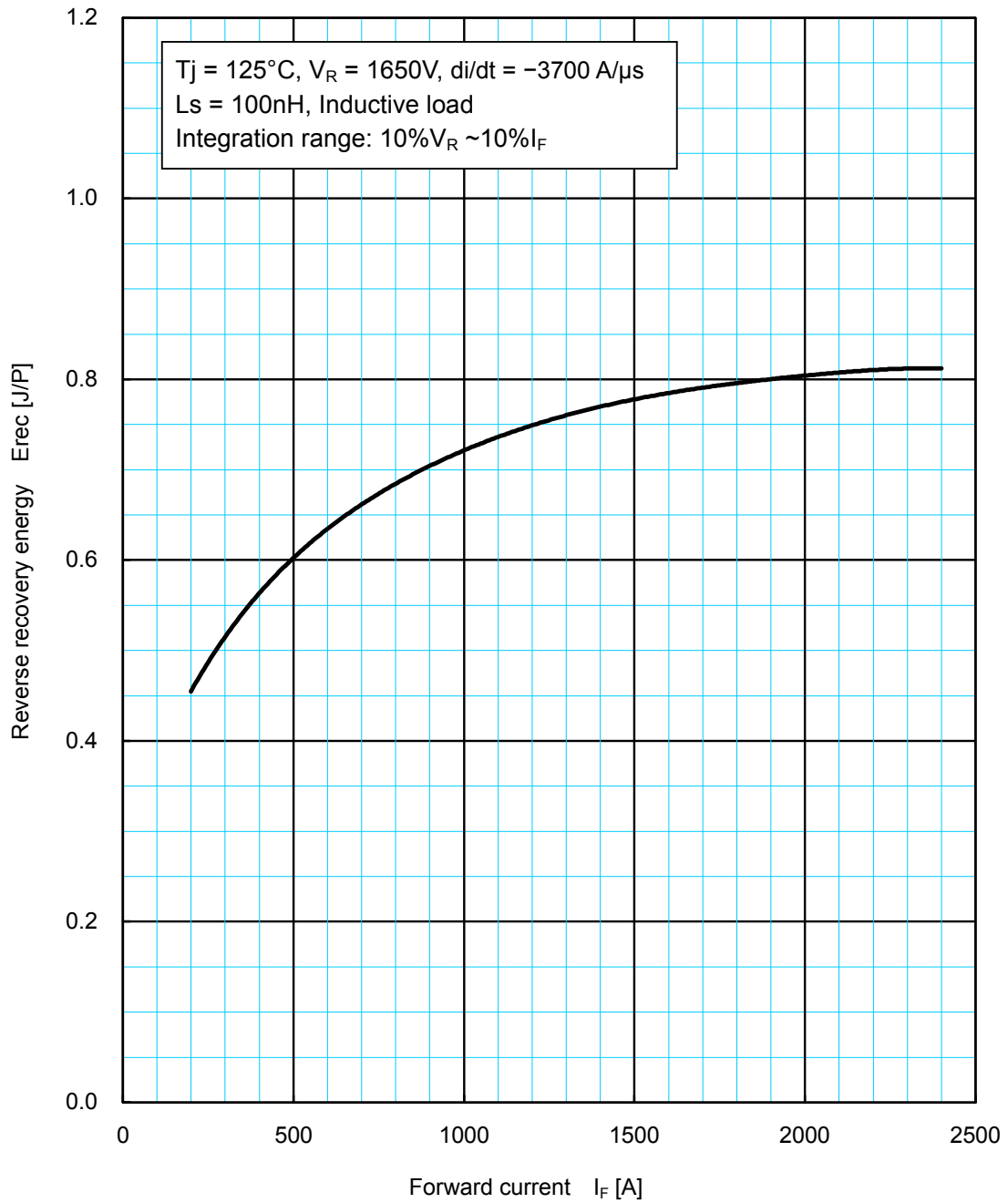

Reverse recovery energy characteristics (typical)

12-3 Reverse recovery current characteristics

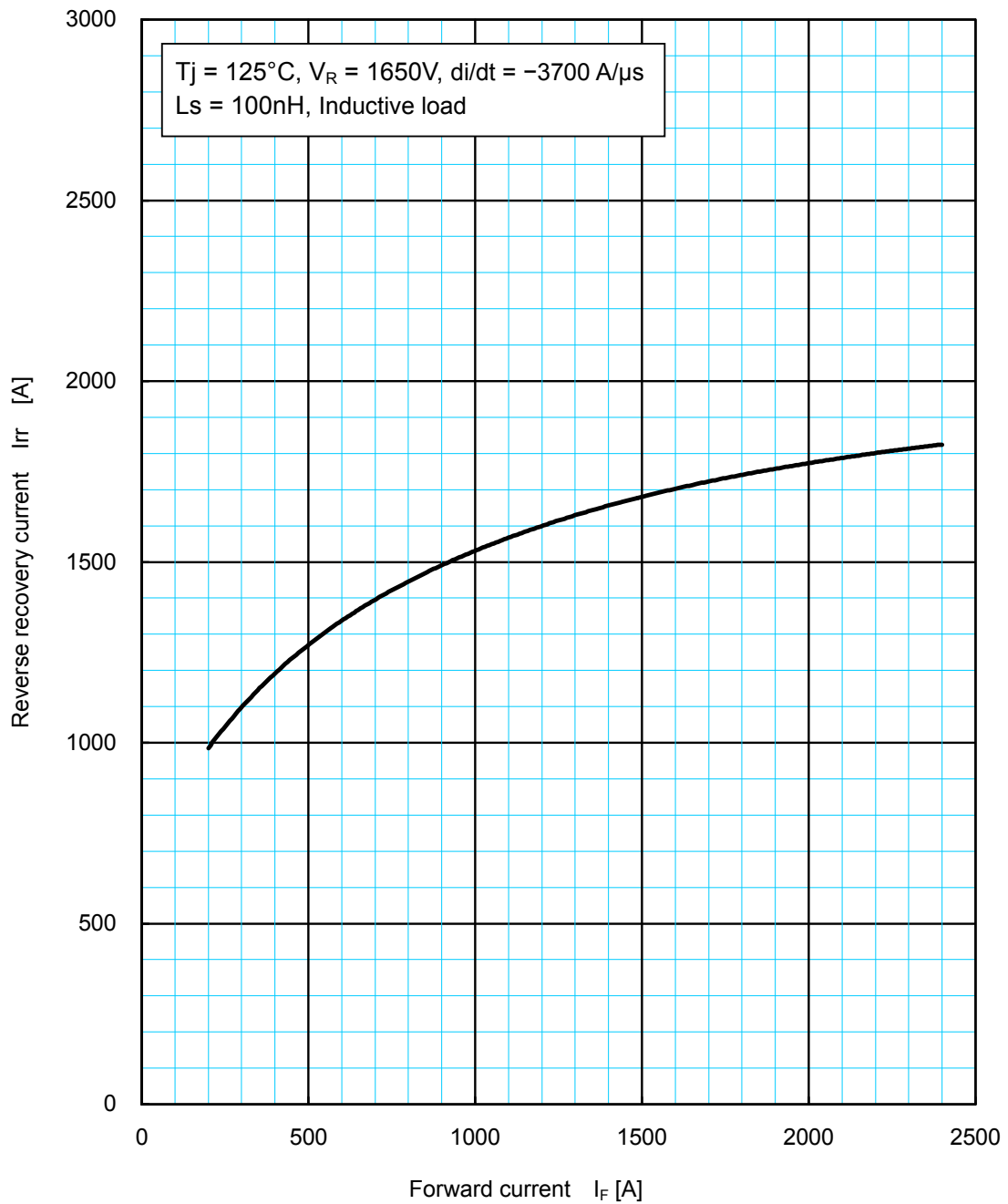

Reverse recovery current characteristics (typical)

12-4 Transient thermal impedance characteristics

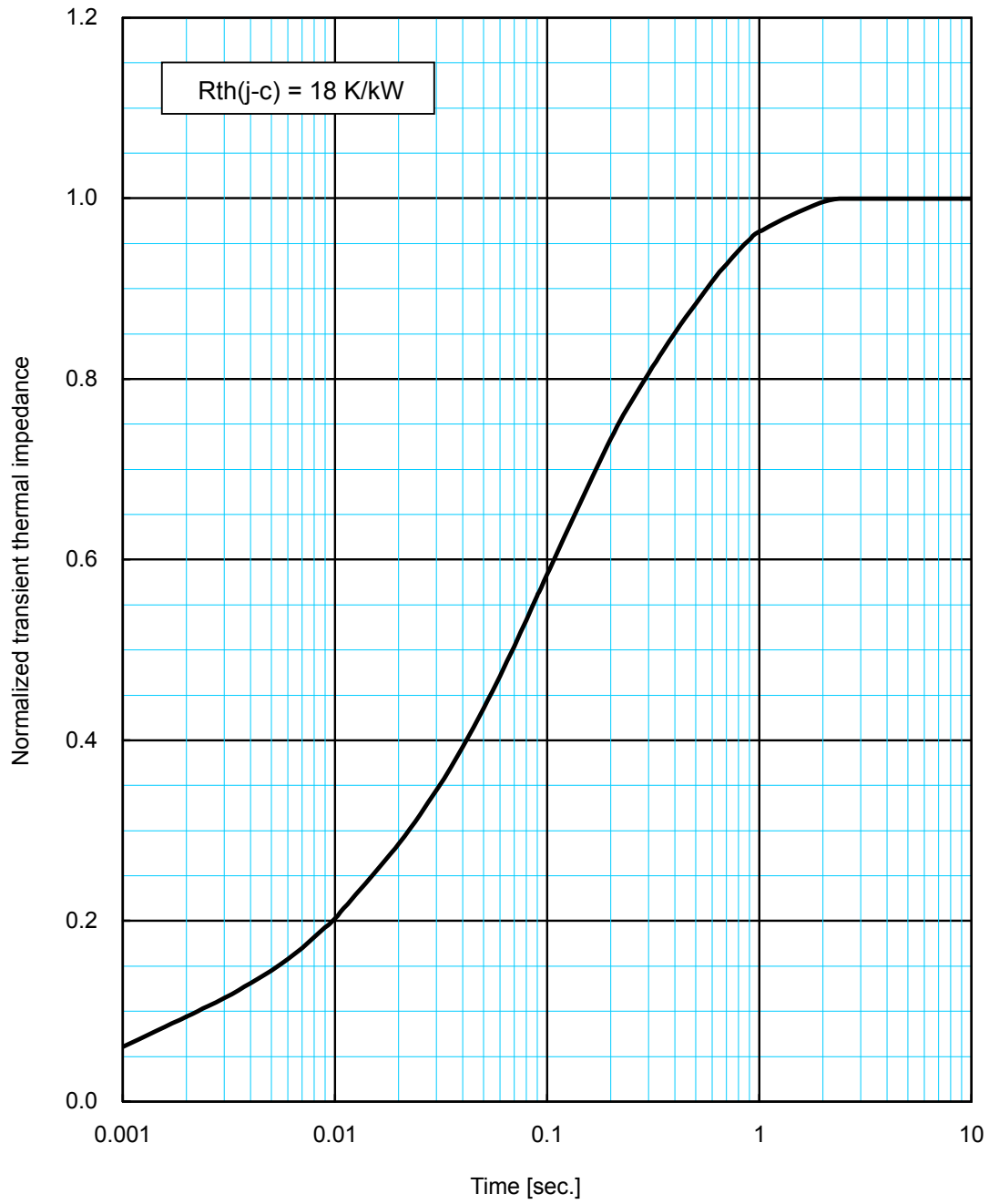

Transient thermal impedance characteristics

12-5 Reverse recovery safe operating area

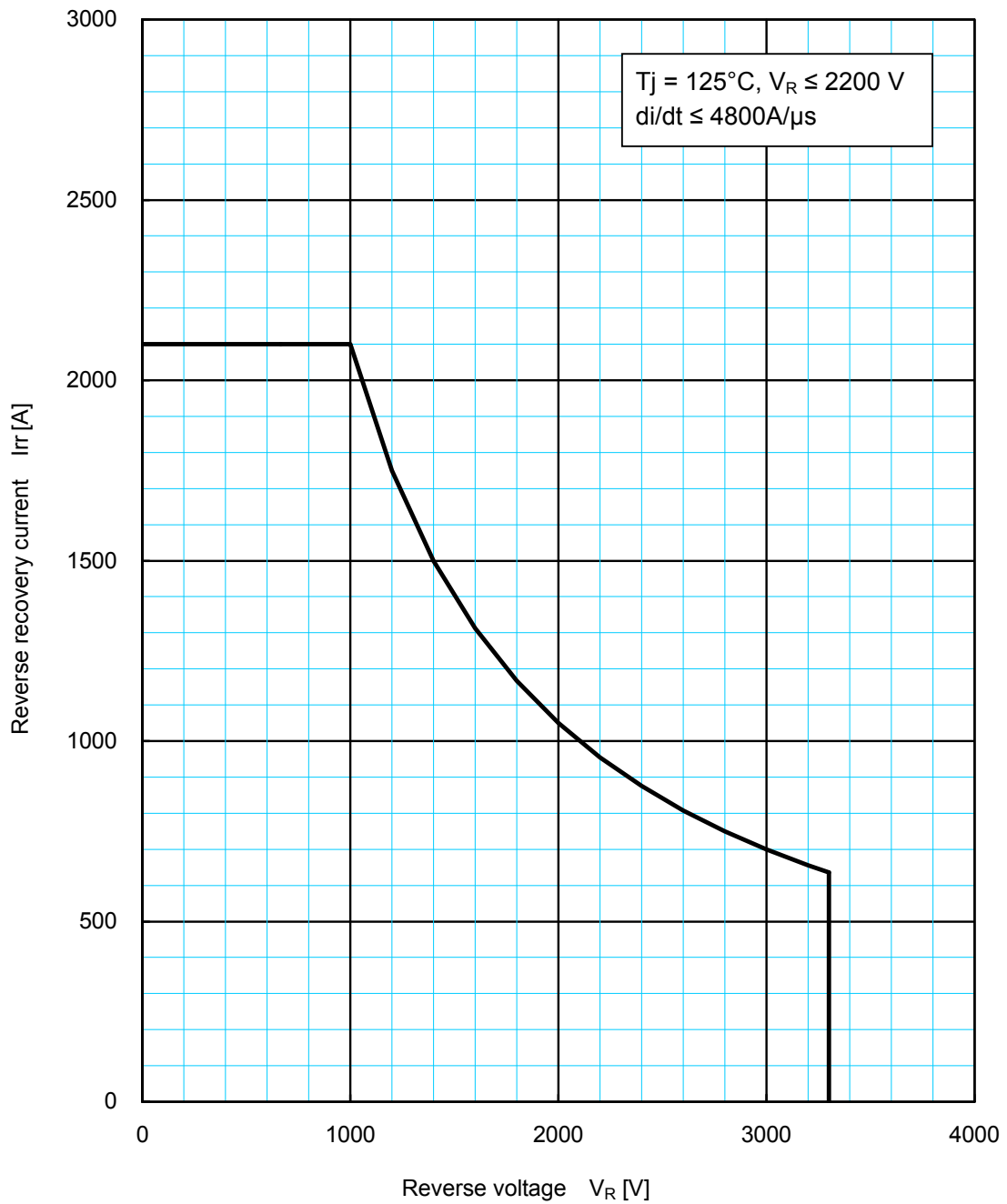

Reverse recovery safe operating area (RRSOA)