

OUTLINE

The R5510Hxxxx Series are CMOS-based voltage regulator (VR) ICs equipped with a voltage detector (V_{DET}). VR function of the R5510Hxxxx has features of high ripple rejection, low dropout voltage, high output voltage accuracy, and ultra-low supply current. Each of these ICs consists of a voltage reference unit, an error amplifier, resistors for setting output voltage, a current limit circuit, and a voltage detector. Each of the R5510HxxxL/M/N types includes also a chip enable circuit. The output of built-in voltage detector is Nch open drain type. The R5510HxxxD type has a pin for connecting external capacitor to set a certain reset delay time instead of chip enable control pin. VR Output Voltage of the R5510HxxxE/F/G types is adjustable with external resistors.

The regulator output voltage except R5510HxxxE/F/G types and the detector threshold voltage are fixed in the IC. Low supply current by the merit of CMOS process and built-in transistors with low ON-resistance make low dropout voltage. These regulators in the R5510Hxxxx Series are remarkable improvement on the current regulators in terms of ripple rejection, input transient response, and load transient response. Furthermore, the R5510HxxxA to G series can supervise input voltage by the built-in detector. R5510HxxxH/J/K types can supervise V_{SEN} pin voltage by the built-in detector.

Thus, the R5510Hxxxx series are suitable for power supply for CD-drives, DVD-drives, and so forth.

Since the package for these ICs is the SOT-89-5 package, high density mounting of the ICs on boards is possible.

FEATURES

- Ultra-Low Supply Current Typ. 150 μ A (VR), Typ. 10 μ A (VD)
- Low Standby Current Typ. 0.1 μ A (VR) for L/M/N type
- High Ripple Rejection Typ. 60dB ($f=1$ kHz) (VR)
- Output Current Min. 300mA ($V_{IN}=V_{OUT}+1$ V)
- Output Voltage (VR) Stepwise setting with a step of 0.1V in the range of 2.5V to 5.0V
- High Output Voltage Accuracy $\pm 2.0\%$ (VR) except E/F/G type,
 $\pm 2.0\%$ (Reference Voltage for adjustable VR) for E/F/G type
 $\pm 2.5\%$ (VD)* Output type of VD is Nch open drain.
- Low Dropout Voltage Typ. 0.2V ($I_{OUT}=100$ mA) (VR)
- Small Package SOT-89-5
- Built-in Current Limit Circuits (VR)
- Low Temperature-drift Coefficient of Output Voltage... Typ. ± 100 ppm/ $^{\circ}$ C
- Absolute Maximum Voltage 9V
- Built-in Reset Delay Circuits..... L/E/H (no delay time), M/F/J (delay time; 10ms), N/G/K (delay time; 50ms)
or Used with External Capacitor for Setting Reset Delay time..... D type

- Monitoring V_{DD} voltage Except H/J/K type
or monitoring sense pin (V_{SEN}) voltage..... H/J/K type

APPLICATIONS

- Power source for CD-drives and DVD-drives.

BLOCK DIAGRAMS

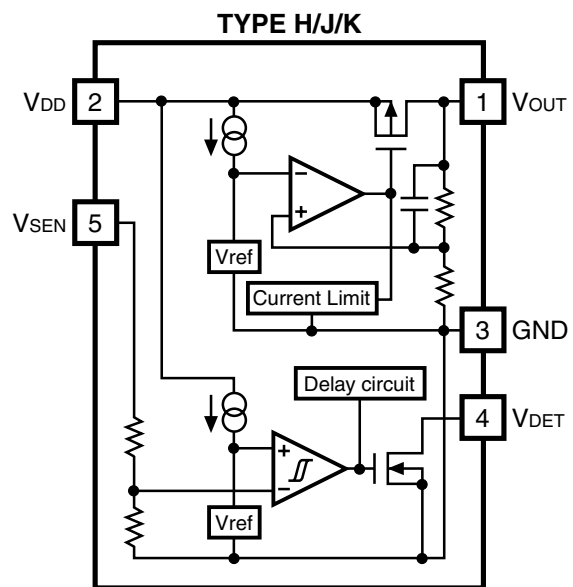
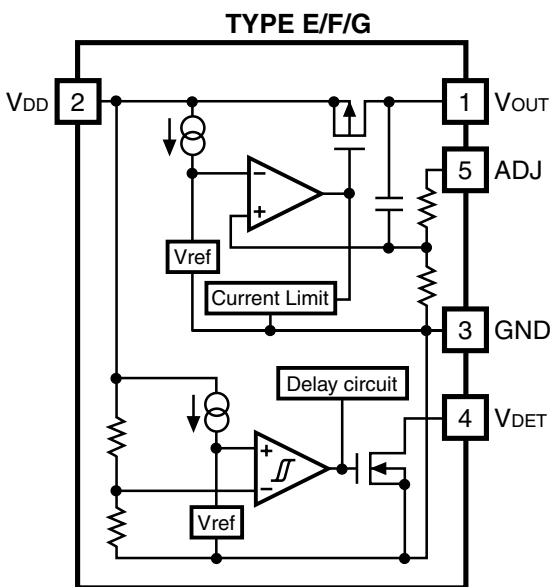
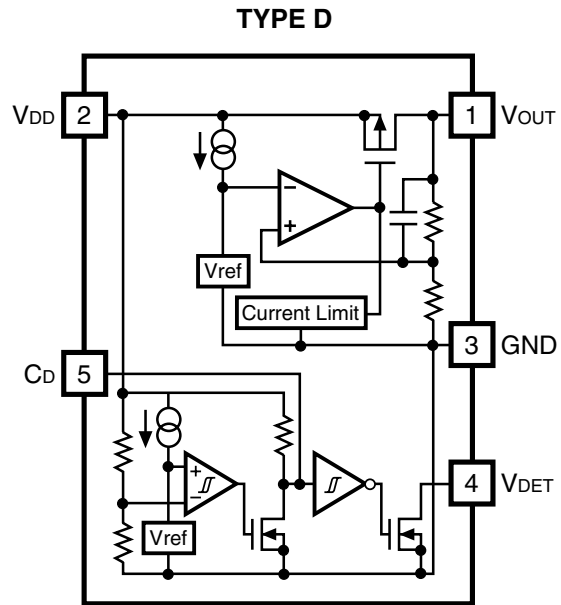
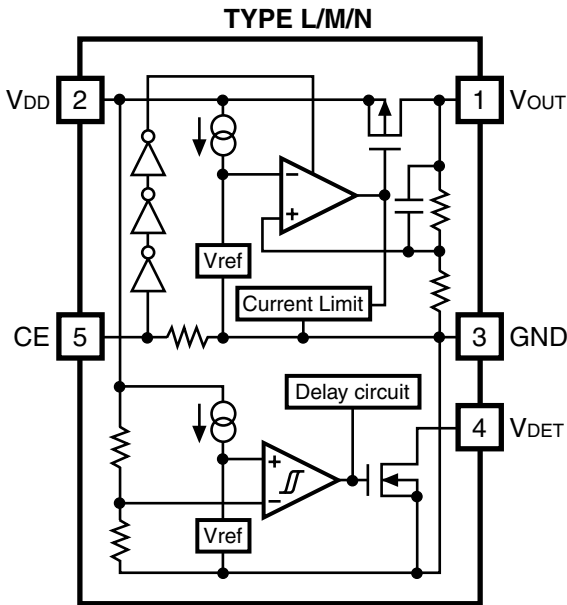

SELECTION GUIDE

The output voltage, the usage of pin No.5 (as a kind of types in the R5510Hxxxx series), the taping type can be selected at the user's request. The selection can be made by designating the part number as follows;

R5510Hxxxx-xx → Part Number

↑ ↑ ↑

a b c

Code	Contents
a	Serial Number for Voltage Setting
b	Designation of option; L: Built-in Chip Enable Circuit (V_{DET} output delay time is typically 0.5ms.) M: Built-in Chip Enable Circuit (V_{DET} output delay time is set typically at 10ms.) N: Built-in Chip Enable Circuit (V_{DET} output delay time is set typically at 50ms.) D: Used with External Capacitor for setting output delay E: Output Voltage Adjustable Regulator (V_{DET} output delay time is typically 0.5ms.) F: Output Voltage Adjustable Regulator (V_{DET} output delay time is set typically at 10ms.) G: Output Voltage Adjustable Regulator (V_{DET} output delay time is set typically at 50ms.) H: Voltage Detector with Individual Sense pin (V_{DET} output delay time is typically 0.5ms.) J: Voltage Detector with Individual Sense pin (V_{DET} output delay time is set typically at 10ms.) K: Voltage Detector with Individual Sense Pin (V_{DET} output delay time is set typically at 50ms.)
c	Designation of Taping Type; T1 or T2 (Refer to Taping Specifications)

PIN CONFIGURATION

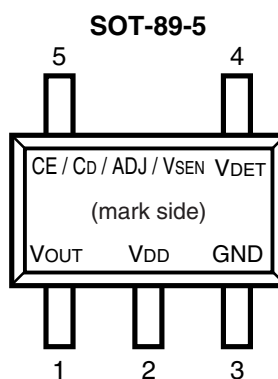

PIN DESCRIPTION

Pin No.	Symbol	Description
1	V _{OUT}	Voltage Regulator Output Pin
2	V _{DD}	Input and Sense Pin of Voltage Detector
3	GND	Ground Pin
4	V _{DET}	Voltage Detector Output Pin (When Voltage detector detects the lowering voltage than setting threshold level, the output voltage level is "L". While V _{DD} Input level at reset detection or before crossing threshold level from higher voltage than it, the output voltage level is "H".)
5	CE	(L/M/N type) Chip Enable Pin
	CD	(D type) Pin for External Capacitor for Setting Output Delay of Voltage Detector
	ADJ	(E/F/G type) Adjustable Regulator feedback Input Pin (Connect to resistor voltage divider.)
	V _{SEN}	(H/J/K type) Sense Pin for Voltage Detector

ABSOLUTE MAXIMUM RATINGS

Symbol	Item	Rating	Unit
V _{IN}	Input Voltage	9.0	V
V _{CE}	Input Voltage (CE Input Pin)*Note	-0.3 ~ V _{IN} +0.3	V
V _{SEN}	Input Voltage (V _{SEN} Input Pin)	-0.3 ~ V _{IN} +0.3	V
V _{DET}	Output Voltage (V _{DET} Output Pin)	-0.3 ~ 9.0	V
V _{OUT}	Output Voltage	-0.3 ~ V _{IN} +0.3	V
I _{OUT}	Output Current	450	mA
P _D	Power Dissipation	500	mW
T _{opt}	Operating Temperature Range	-40 ~ 85	°C
T _{stg}	Storage Temperature Range	-55 ~ 125	°C

*Note: This item is for R5510xxxL/M/N Version.

ELECTRICAL CHARACTERISTICS

• R5510HxxxL/M/N

(T_{opt}=25°C)

Symbol	Item	Conditions	Min.	Typ.	Max.	Unit
V _{IN}	Input Voltage				8.0	V
I _{SS1}	Supply Current1	V _{IN} -V _{OUT} =1.0V V _{IN} =V _{CE}		150	300	μA
I _{SS2}	Supply Current2	V _{IN} =-V _{DET} -0.16V V _{CE} =0V		10	20	μA
I _{SS3}	Supply Current3	V _{IN} =-V _{DET} +2.0V V _{CE} =0V		10	20	μA

VR part

(T_{opt}=25°C)

Symbol	Item	Conditions	Min.	Typ.	Max.	Unit
V _{OUT}	Output voltage	V _{IN} -V _{OUT} =1.0V I _{OUT} =80mA	V _{SET} ×0.98	V _{SET}	V _{SET} ×1.02	
I _{OUT1}	Output Current	V _{IN} -V _{OUT} =1.0V	300		400	mA
ΔV _{OUT} /ΔI _{OUT}	Load Regulation	V _{IN} -V _{OUT} =1.0V 1mA≤I _{OUT} ≤80mA		60	120	mV
V _{DIF}	Dropout Voltage	I _{OUT} =100mA		0.2	0.3	V
ΔV _{OUT} /ΔV _{IN}	Line regulation	I _{OUT} =80mA V _{OUT} +0.5V≤V _{IN} ≤8V		0.1	0.2	%/V
RR	Ripple Rejection	f=1kHz, Ripple 0.5Vp-p V _{IN} -V _{OUT} =2.0V		60		dB
ΔV _{OUT} /ΔT	Output Voltage Temperature Coefficient	I _{OUT} =10mA -40°C≤T _{opt} ≤85°C		±100		ppm /°C
I _{LM}	Short Current Limit	V _{OUT} =0V		50		mA
R _{PD}	Pull-down resistance for CE pin		2.5	5	10	MΩ
V _{CEH}	CE Input Voltage "H"		1.5		V _{IN}	V
V _{CEL}	CE Input Voltage "L"		0		0.25	V

R5510Hxxxx V_{DET} part(T_{opt}=25°C)

Symbol	Item	Conditions	Min.	Typ.	Max.	Unit
$-V_{DET}$	Detector Threshold		V_{SET} $\times 0.975$	V_{SET}	V_{SET} $\times 1.025$	V
V_{HYS}	Detector Threshold Hysteresis			$-V_{DET}$ $\times 0.05$		V
I_{OUT2}	Output Current	$V_{DD}=1.5V, V_{DS}=0.5V$	1.0	4.5	6.0	mA
V_{DDL}	Minimum Operating Voltage			0.65	0.80	V
$\Delta V_{DET}/\Delta T$	Detector Threshold Temperature Coefficient	$-40^{\circ}C \leq T_{opt} \leq 85^{\circ}C$		± 100		ppm/ °C
tpLH	Output Delay Time	R5510HxxxL		0.5	1.0	ms
tpLH	Output Delay Time	R5510HxxxM	8	10	13	ms
tpLH	Output Delay Time	R5510HxxxN	40	50	70	ms

• **R5510HxxxD**(T_{opt}=25°C)

Symbol	Item	Conditions	Min.	Typ.	Max.	Unit
V_{IN}	Input Voltage				8	V
I_{SS1}	Supply Current1	$V_{IN}-V_{OUT}=1.0V$		150	300	μA

VR part

(T_{opt}=25°C)

Symbol	Item	Conditions	Min.	Typ.	Max.	Unit
V _{OUT}	Output voltage	V _{IN} -V _{OUT} =1.0V I _{OUT} =80mA	V _{SET} ×0.98	V _{SET}	V _{SET} ×1.02	V
I _{OUT1}	Output Current	V _{IN} -V _{OUT} =1.0V	300		400	mA
ΔV _{OUT} /ΔI _{OUT}	Load regulation	V _{IN} -V _{OUT} =1.0V 1mA≤I _{OUT} ≤80mA		60	120	mV
V _{DIF}	Dropout Voltage	I _{OUT} =100mA		0.2	0.3	V
ΔV _{OUT} /ΔV _{IN}	Line regulation	I _{OUT} =80mA V _{OUT} +0.5V≤V _{IN} ≤8V		0.1	0.2	%/V
RR	Ripple Rejection	f=1kHz, Ripple 0.5Vp-p V _{IN} -V _{OUT} =2.0V		60		DB
ΔV _{OUT} /ΔT	Output Voltage Temperature Coefficient	I _{OUT} =10mA -40°C≤T _{opt} ≤85°C		±100		ppm /°C
I _{LIM}	Short Current Limit	V _{OUT} =0V		50		mA

V_{DET} part(T_{opt}=25°C)

Symbol	Item	Conditions	Min.	Typ.	Max.	Unit
-V _{DET}	Detector Threshold		V _{SET} ×0.975	V _{SET}	V _{SET} ×1.025	V
V _{HYS}	Detector Threshold Hysteresis				-V _{DET} × 0.05	V
I _{OUT2}	Output Current 2	V _{DD} =1.5V, V _{DS} =0.5V	1.0	4.5	6.0	mA
tpLH	Output Delay Time			500		μs
V _{DDL}	Minimum Operating Voltage			0.65	0.80	V
Δ-V _{DET} /ΔT	Detector Threshold Temperature Coefficient	-40°C≤T _{opt} ≤85°C		±100		ppm /°C

R5510Hxxxx

• R5510HxxxE/F/G

(T_{opt}=25°C)

Symbol	Item	Condition	Min.	Typ.	Max.	Unit
V _{IN}	Input voltage				8	V
I _{SS1}	Supply Current1	V _{IN} -V _{OUT} =1.0V		150	300	μA

VR part

(T_{opt}=25°C)

Symbol	Item	Conditions	Min.	Typ.	Max.	Unit
V _{OUT}	Reference Voltage for Adjustable Voltage Regulator	V _{OUT} =V _{ADJ} I _{OUT} =80mA	1.960	2.000	2.040	V
R _{VOUT}	Output Voltage Range		2.5		5.0	V
I _{OUT1}	Output Current		300		400	mA
ΔV _{OUT} /ΔI _{OUT}	Load regulation			60	120	mV
V _{DIF}	Dropout Voltage			0.2	0.3	V
ΔV _{OUT} /ΔV _{IN}	Line regulation	I _{OUT} =80mA V _{OUT} +0.5V≤V _{IN} ≤8V		0.1	0.2	%/V
RR	Ripple Rejection	f=1kHz, Ripple 0.5Vp-p		60		dB
ΔV _{OUT} /ΔT	Output Voltage Temperature Coefficient	I _{OUT} =10mA -40°C≤T _{opt} ≤85°C		±100		ppm/°C
I _{LIM}	Short Current Limit	V _{OUT} =0V		50		mA

V_{DET} part

(T_{opt}=25°C)

Symbol	Item	Conditions	Min.	Typ.	Max.	Unit
-V _{DET}	Detector Threshold		V _{SET} ×0.975	V _{SET}	V _{SET} ×1.025	V
V _{HYS}	Detector Threshold Hysteresis			-V _{DET} ×0.05		V
I _{OUT2}	Output Current	V _{DD} =1.5V, V _{DS} =0.5V	1.0	4.5	6.0	mA
V _{DDL}	Minimum Operating Voltage			0.65	0.80	V
Δ-V _{DET} /ΔT	Detector Threshold Temperature Coefficient	-40°C ≤T _{opt} ≤ 85°C		±100		ppm/°C
tpLH	Output Delay Time (*1)	R5510HxxxE		0.5	1.0	ms
tpLH		R5510HxxxF	8	10	13	ms
tpLH		R5510HxxxG	40	50	70	ms

(*1) When V_{DET} Pin is pulled up through 470kΩ to V_{DD}, this value means the time interval from the rising edge of V_{DD} pulse between 0.8V→ (+V_{DET}) +2.0V to when the Output Voltage reaches to the level of ((+V_{DET}) +2.0V)/2.

• R5510HxxxH/J/K

(T_{opt} = 25°C)

Symbol	Item	Conditions	Min.	Typ.	Max.	Unit
V _{IN}	Input Voltage				8	V
I _{SS1}	Supply Current1	V _{IN} -V _{OUT} =1.0V		150	300	μA

VR part

(T_{opt} = 25°C)

Symbol	Item	Conditions	Min.	Typ.	Max.	Unit
V _{OUT}	Output voltage	V _{IN} -V _{OUT} =1.0V I _{OUT} =80mA	V _{SET} ×0.98	V _{SET}	V _{SET} ×1.02	V
I _{OUT1}	Output Current	V _{IN} -V _{OUT} =1.0V	300		400	mA
ΔV _{OUT} /ΔI _{OUT}	Load regulation	V _{IN} -V _{OUT} =1.0V 1mA ≤ I _{OUT} ≤ 80mA		60	120	mV
V _{DIF}	Dropout Voltage	I _{OUT} =100mA		0.2	0.3	V
ΔV _{OUT} /ΔV _{IN}	Line Regulation	I _{OUT} =80mA V _{OUT} +0.5V ≤ V _{IN} ≤ 8V		0.1	0.2	%/V
RR	Ripple Rejection	f=1kHz, Ripple 0.5Vp-p V _{IN} -V _{OUT} =2.0V		60		dB
ΔV _{OUT} /ΔT	Output Voltage Temperature Coefficient	I _{OUT} =10mA -40°C ≤ T _{opt} ≤ 85°C		±100		ppm /°C
I _{LIM}	Short Current Limit	V _{OUT} =0V		50		mA

V_{DET} part(T_{opt} = 25°C)

Symbol	Item	Conditions	Min.	Typ.	Max.	Unit
V _{SEN}	Input Voltage				V _{IN}	V
-V _{DET}	Detector Threshold		V _{SET} ×0.975	V _{SET}	V _{SET} ×1.025	V
V _{HYS}	Detector Threshold Hysteresis			-V _{DET} ×0.05		V
I _{OUT2}	Output Current	V _{DD} =1.5V, V _{DS} =0.5V	1.0	4.5	6.0	mA
V _{DDL}	Minimum Operating Voltage			0.65	0.80	V
Δ-V _{DET} /ΔT	Detector Threshold Temperature Coefficient	-40°C ≤ T _{opt} ≤ 85°C		±100		ppm /°C
tpLH	Output Delay Time	R5510HxxxH		0.5	1.0	ms
tpLH	Output Delay Time	R5510HxxxJ	8	10	13	ms
tpLH	Output Delay Time	R5510HxxxK	40	50	70	ms

TEST CIRCUITS

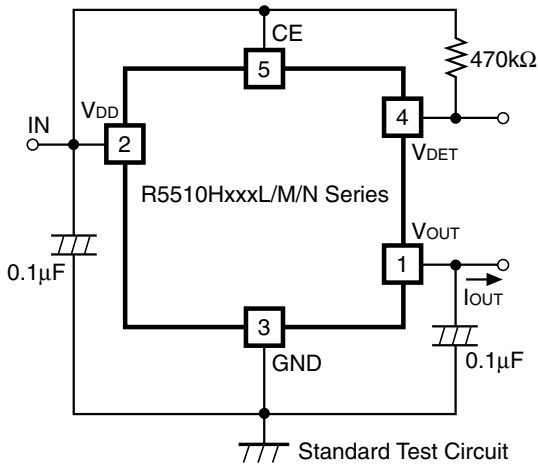

Standard Test Circuit

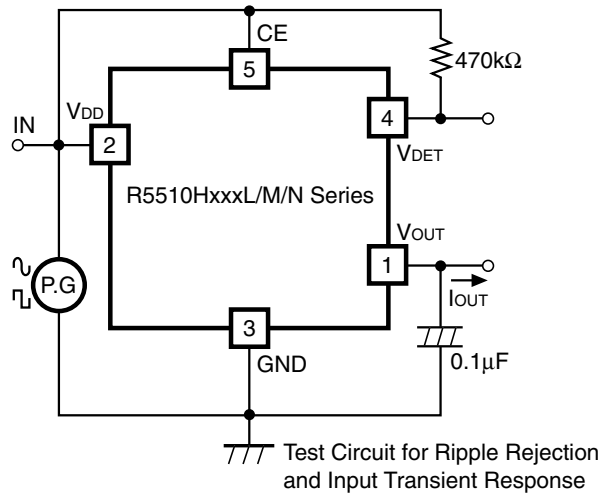

The Test Circuit for Supply Current

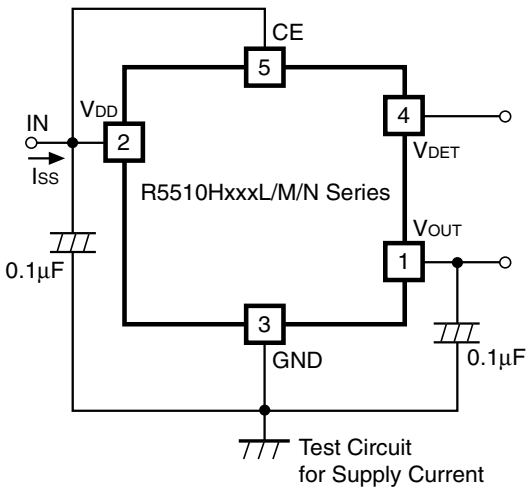

Test Circuit for Ripple Rejection and Input Transient Response

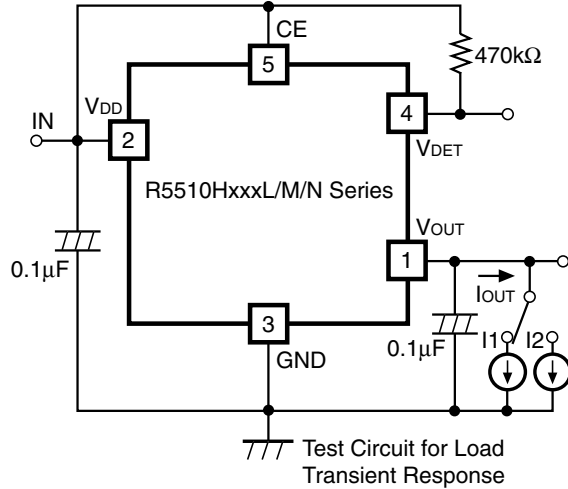

Test Circuit for Load Transient Response

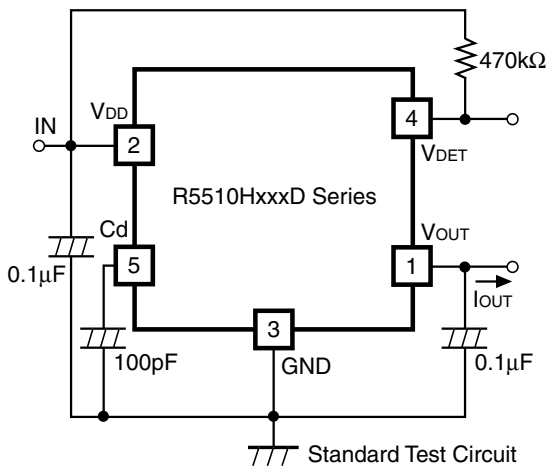

Standard Test Circuit

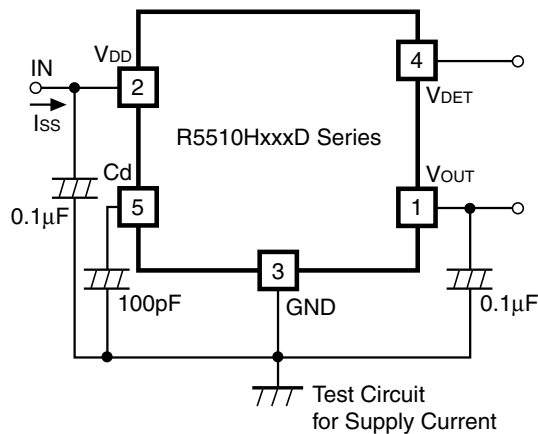

The Test Circuit for Supply Current

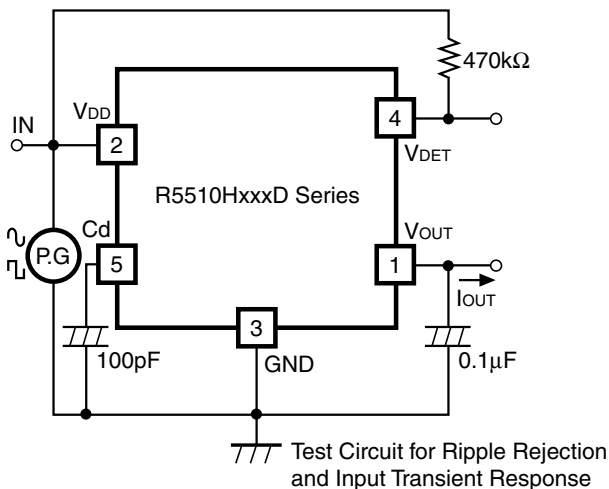

Test Circuit for Ripple Rejection and Input Transient Response

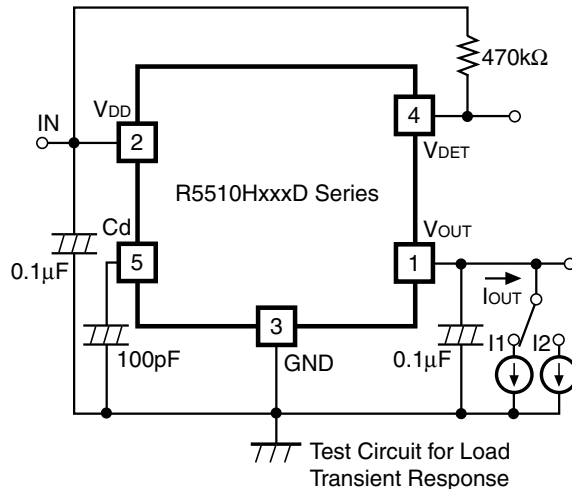

Test Circuit for Load Transient Response

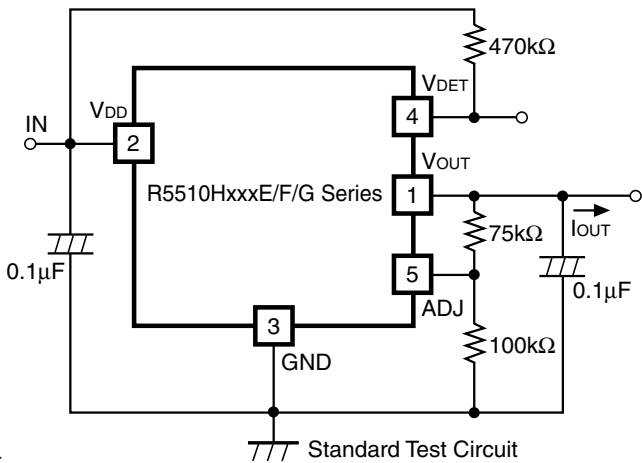

Standard Test Circuit

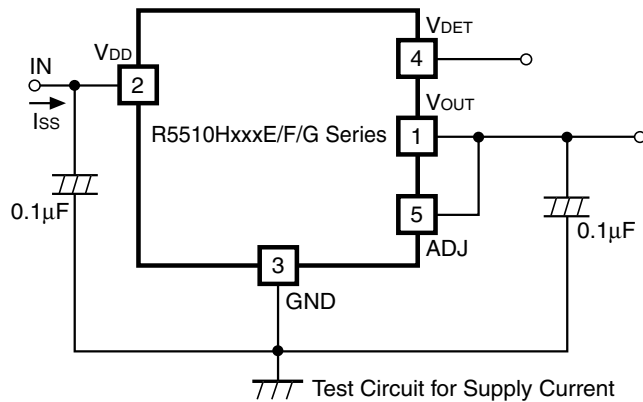

The Test Circuit for Supply Current

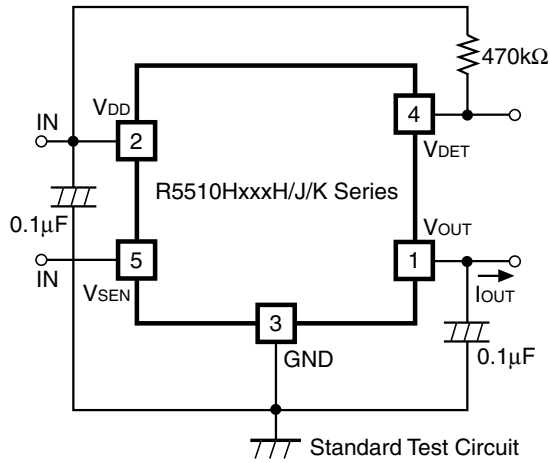

Standard Test Circuit

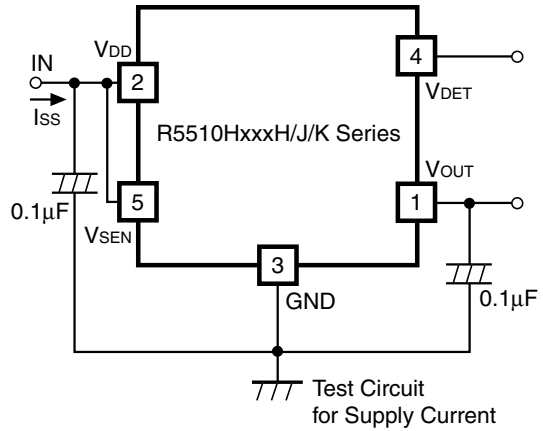

The Test Circuit for Supply Current

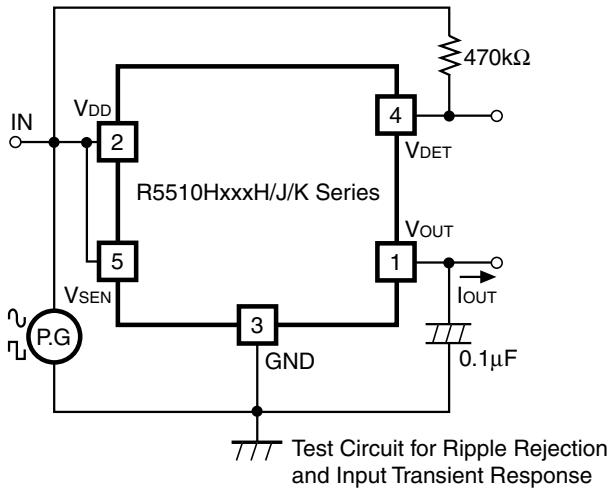

Test Circuit for Ripple Rejection and Input Transient Response

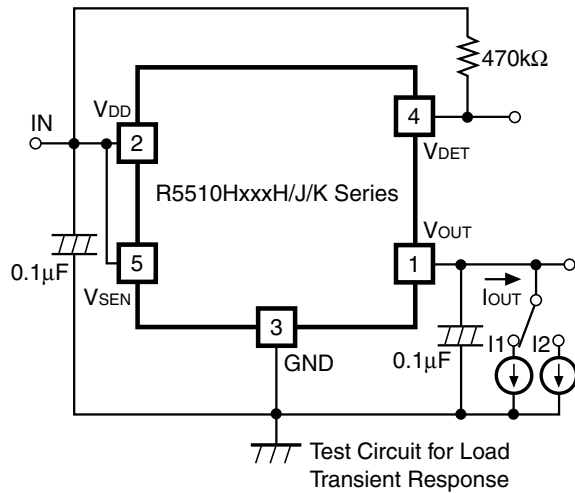

Test Circuit for Load Transient Response

TYPICAL CHARACTERISTICS

1) Output Voltage vs. Output Current (T_{opt}=25°C)

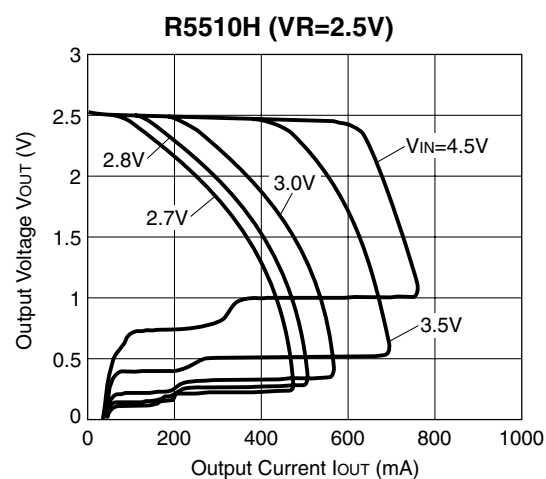
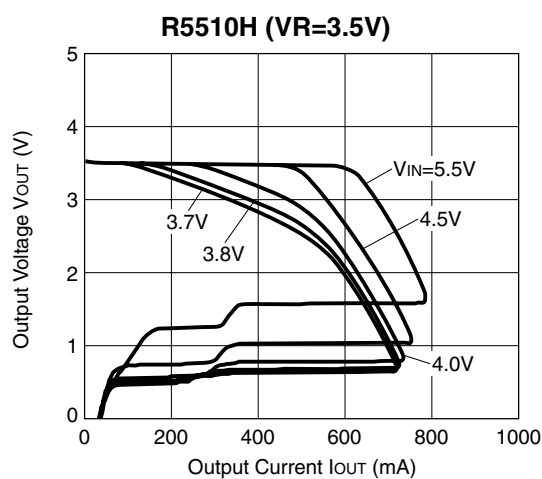
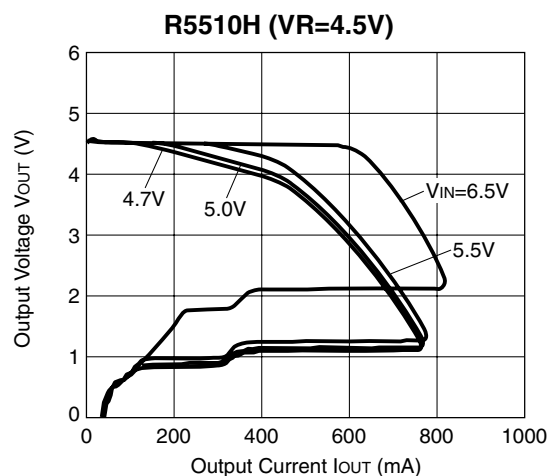
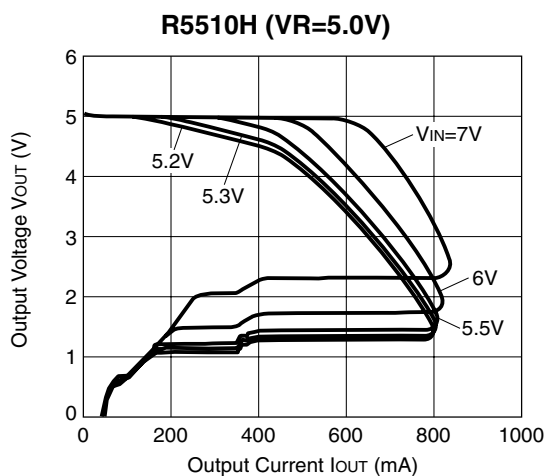

2) Input Voltage vs. Output Voltage (T_{opt}=25°C)

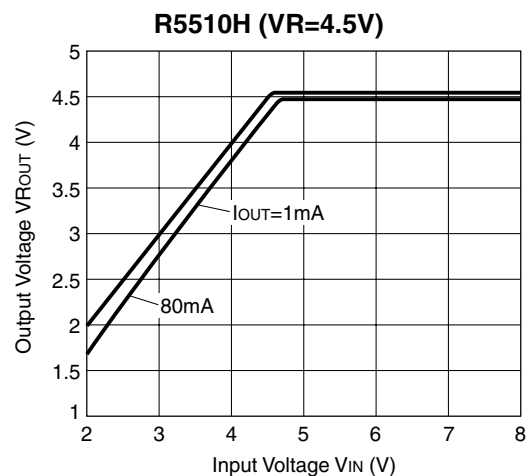
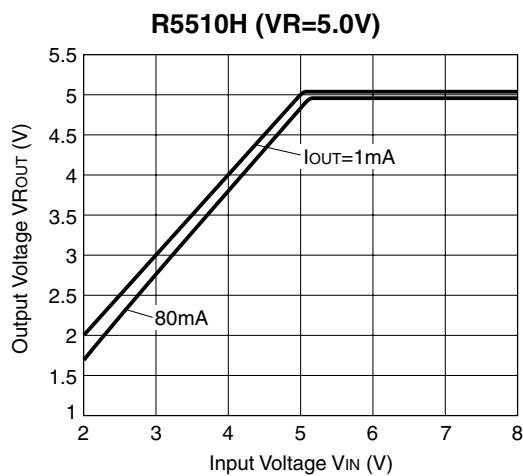

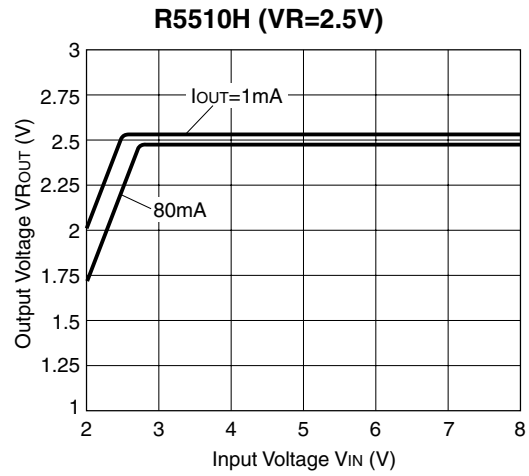
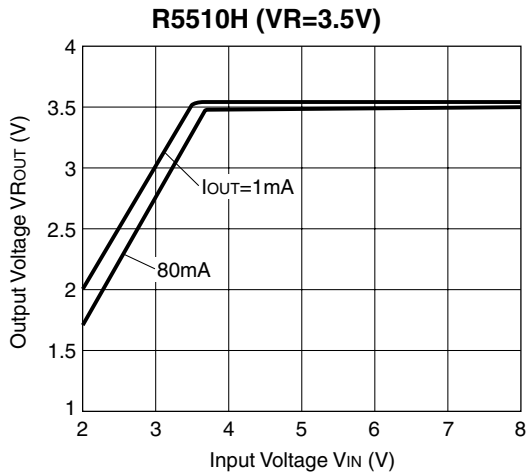

3) Dropout Voltage vs. Output Current

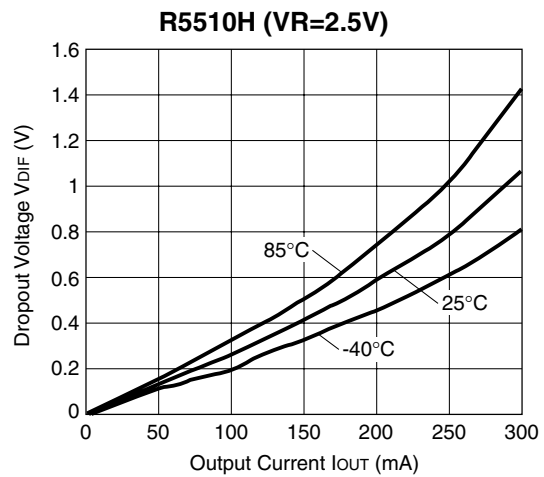
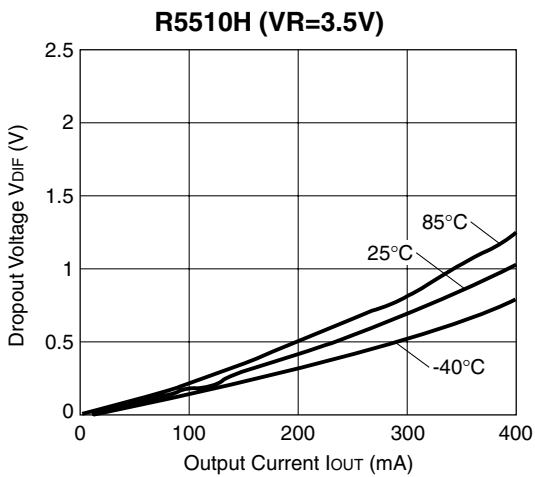
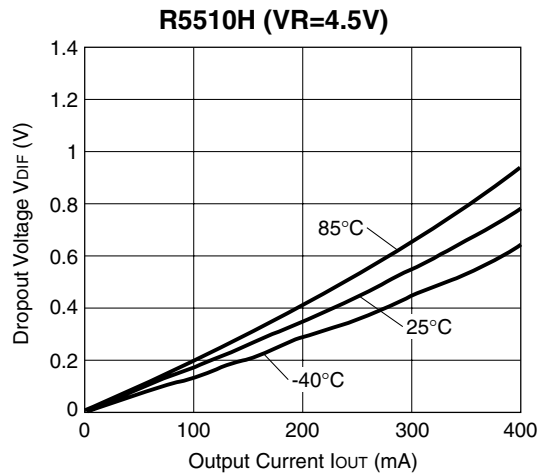
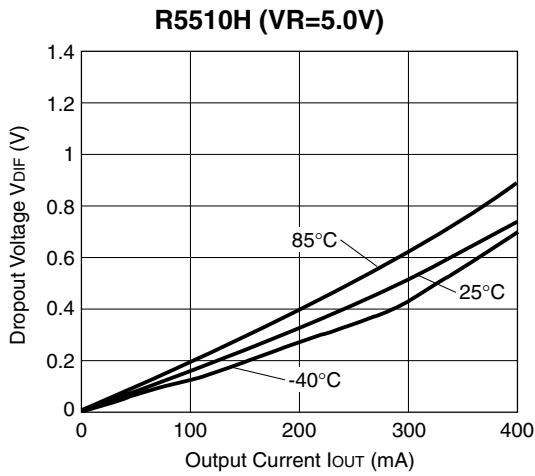

4) Output Voltage vs. Temperature

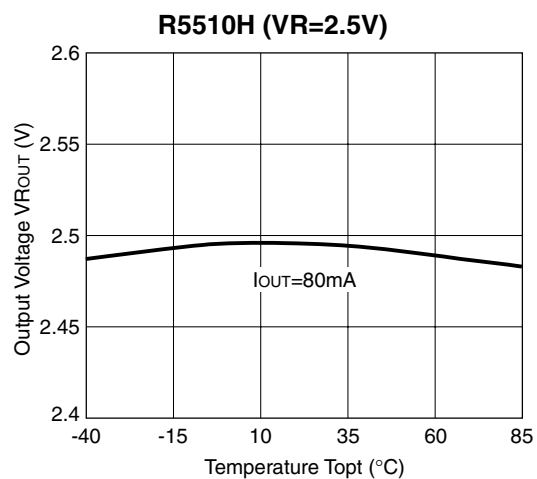
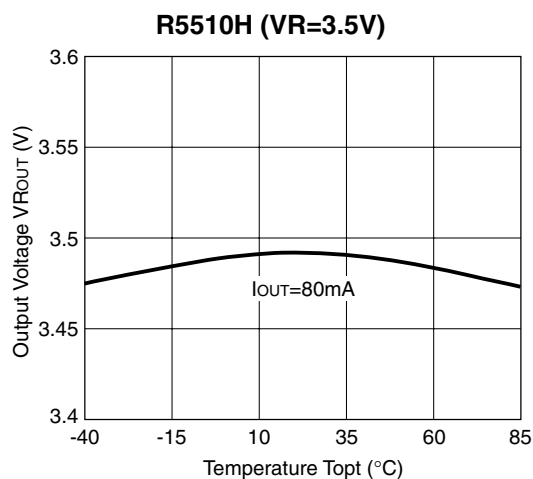
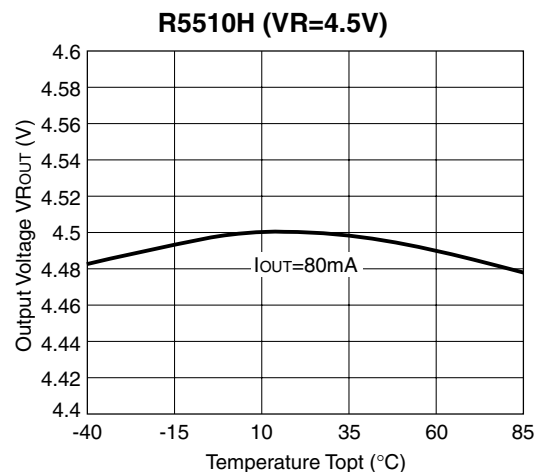
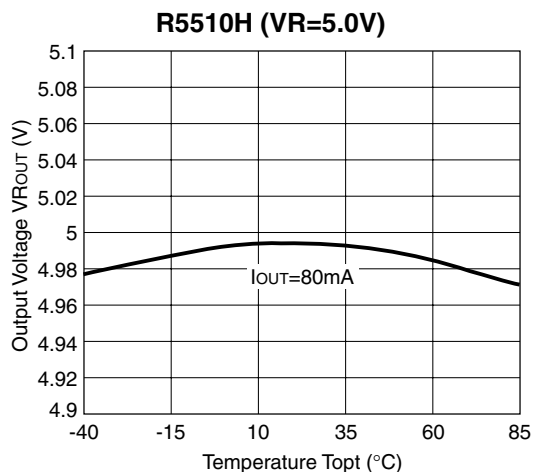
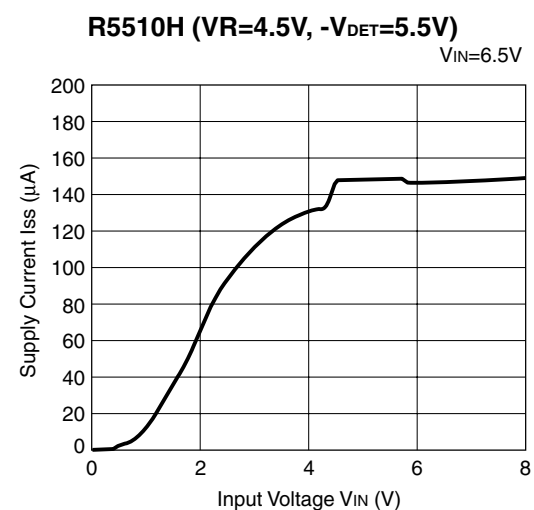
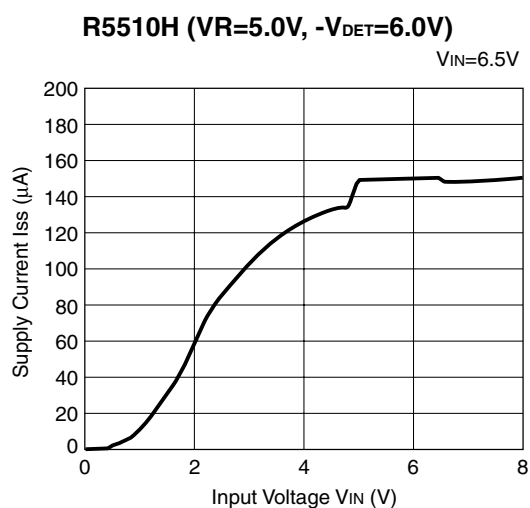
5) Supply Current vs. Input Voltage (T_{opt}=25°C)

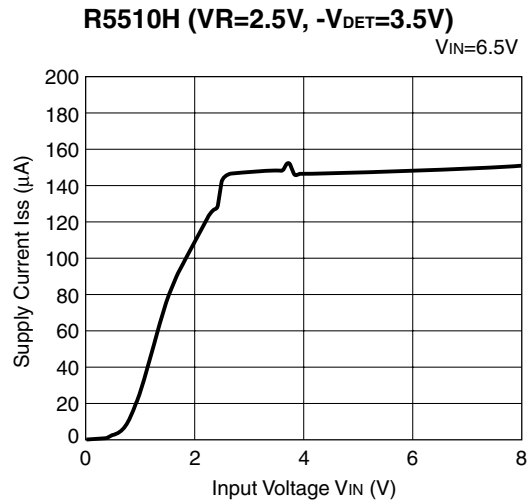
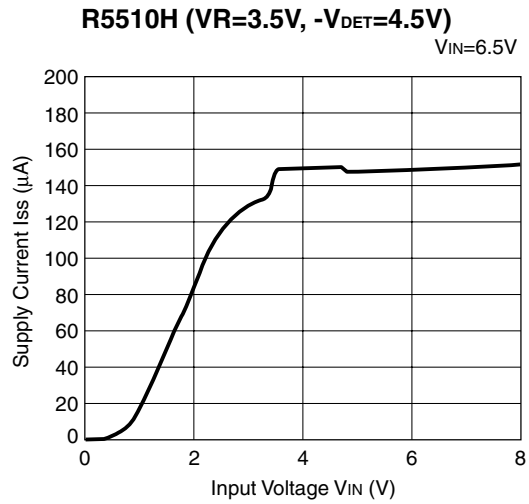

6) Supply Current vs. Temperature

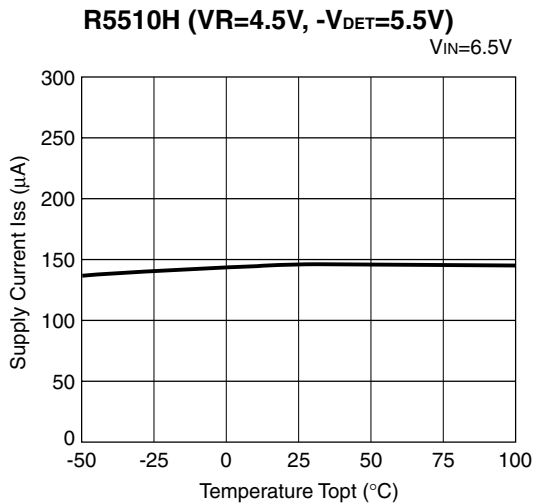
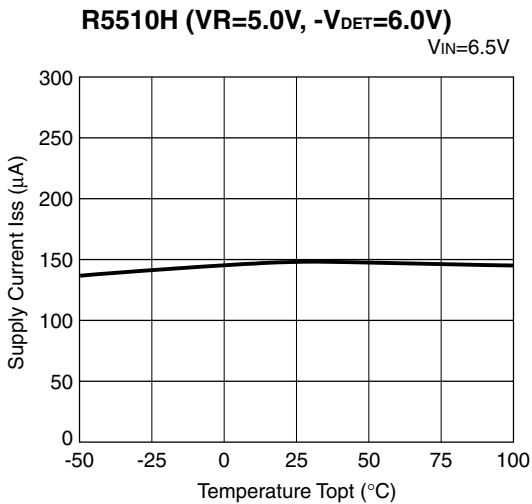

7) Ripple Rejection vs. Frequency

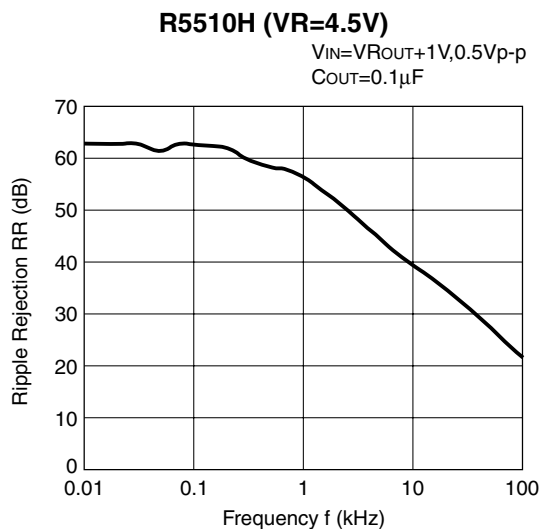
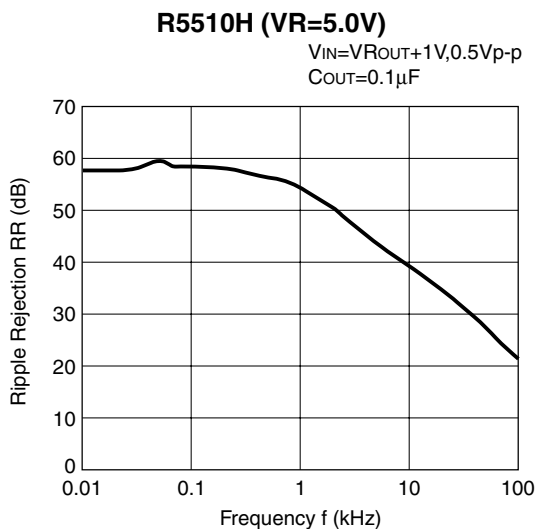

R5510H (VR=3.5V)

$V_{IN}=V_{R_{OUT}}+1V, 0.5V_{p-p}$
 $C_{OUT}=0.1\mu F$

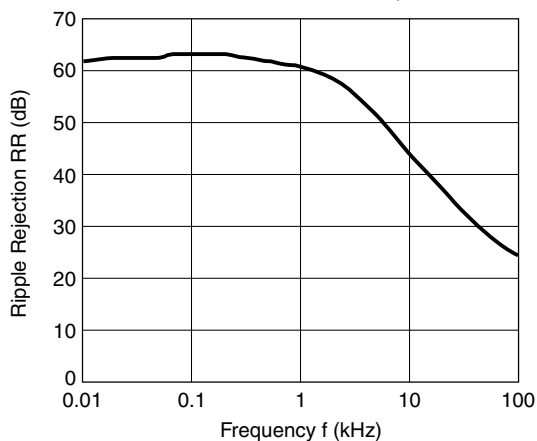

R5510H (VR=2.5V)

$V_{IN}=V_{R_{OUT}}+1V, 0.5V_{p-p}$
 $C_{OUT}=0.1\mu F$

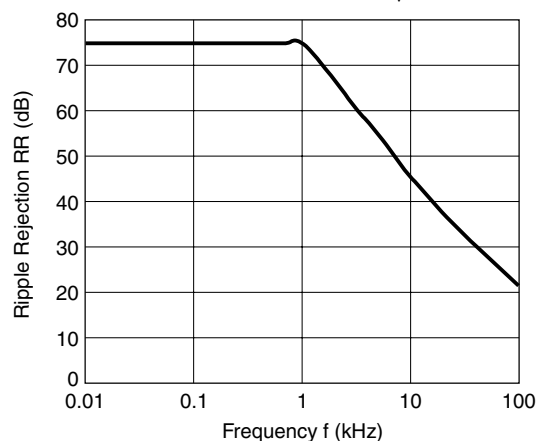

8) Ripple Rejection vs. Input Voltage (DC Bias)

R5510H (VR=5.0V)

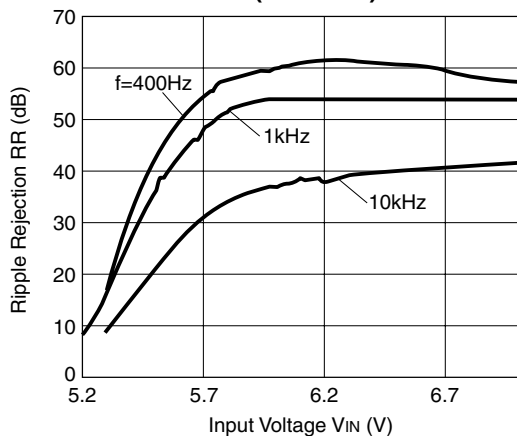

R5510H (VR=4.5V)

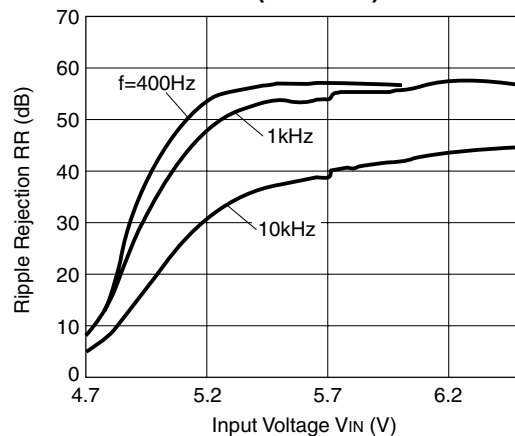

9) Input Transient Response

R5510H (VR=3.5V)

$I_{OUT}=80mA$
 $t_r=t_f=5\mu s$
 $C_{OUT}=0.1\mu F$

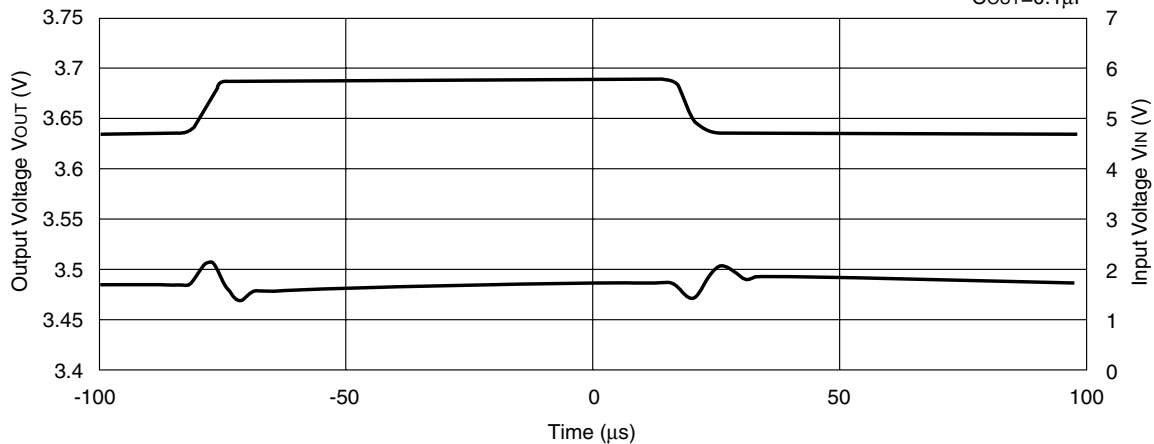

R5510H (VR=2.5V)

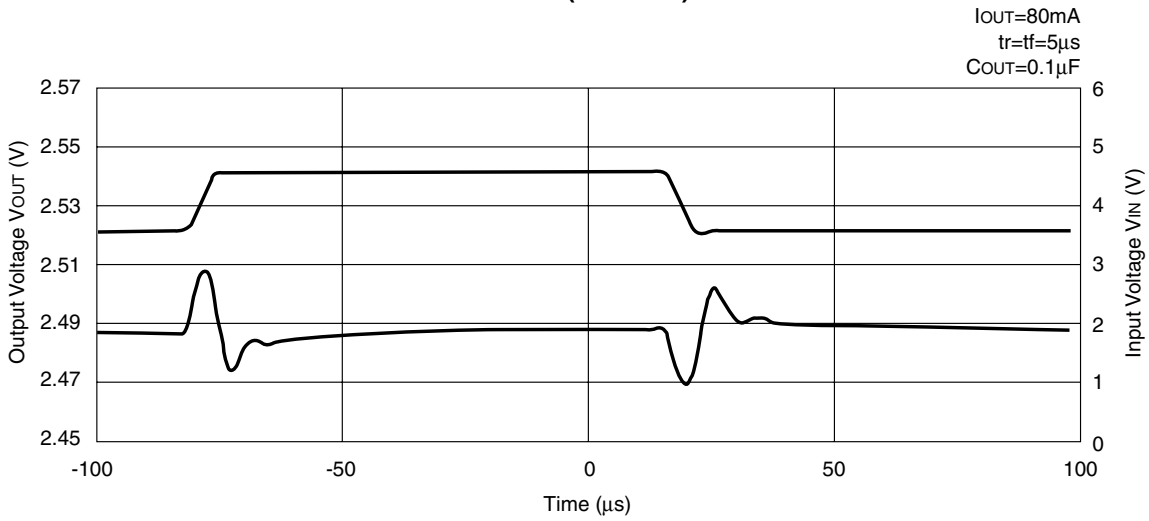

10) Load Transient Response

R5510H (VR=5.0V)

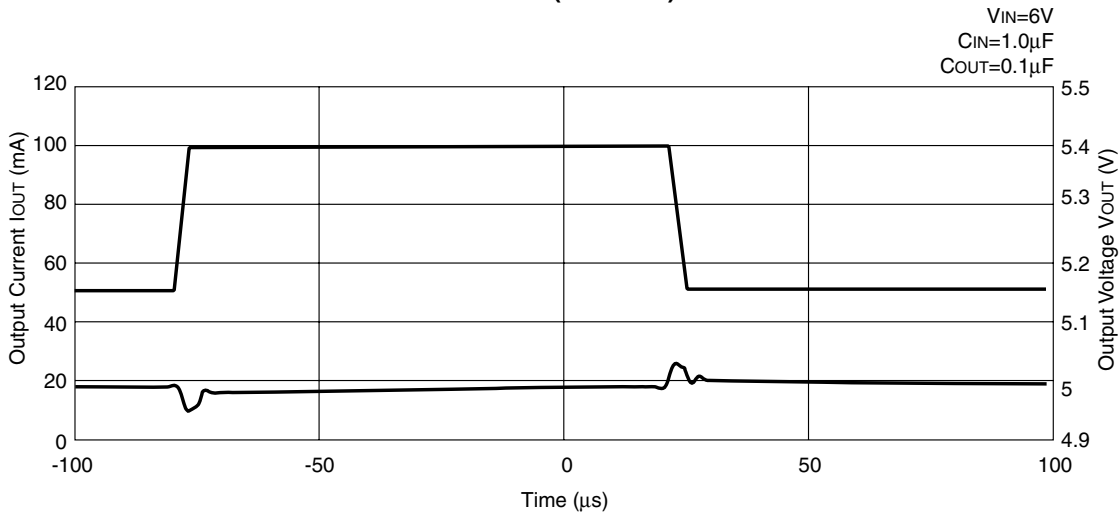

R5510H (VR=4.5V)

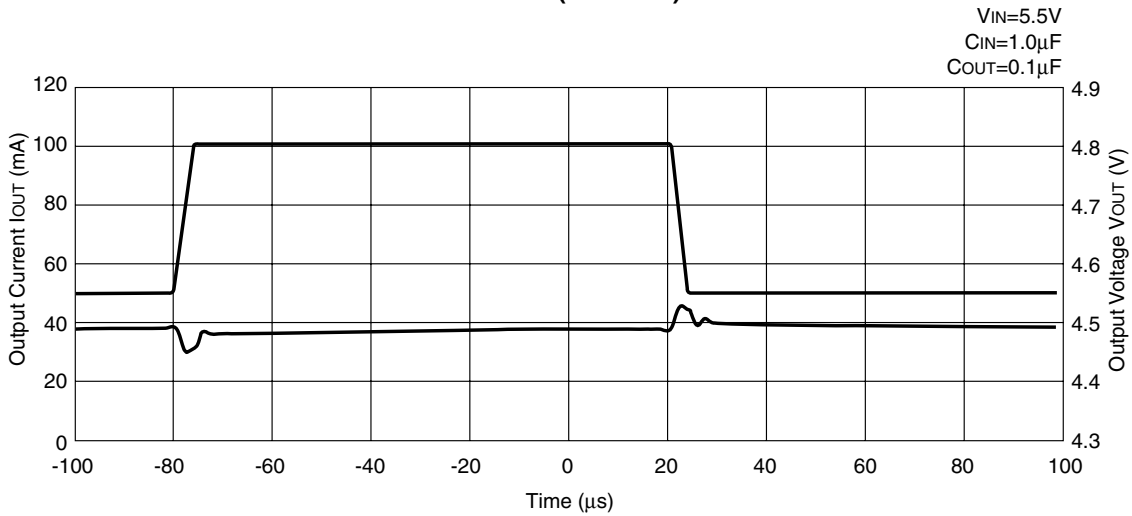

R5510H (VR=3.5V)

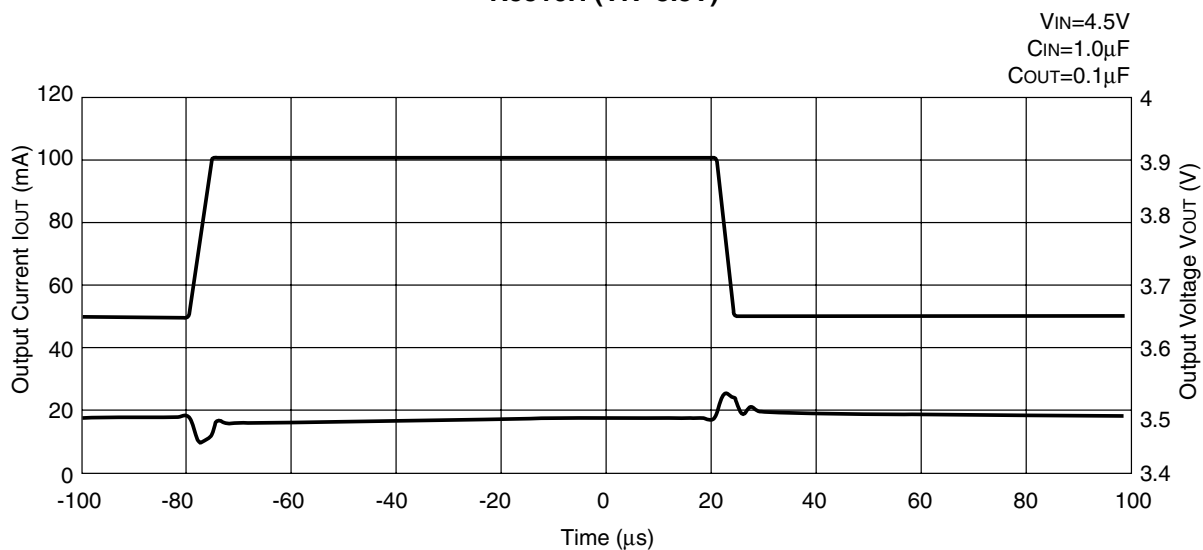

R5510H (VR=2.5V)

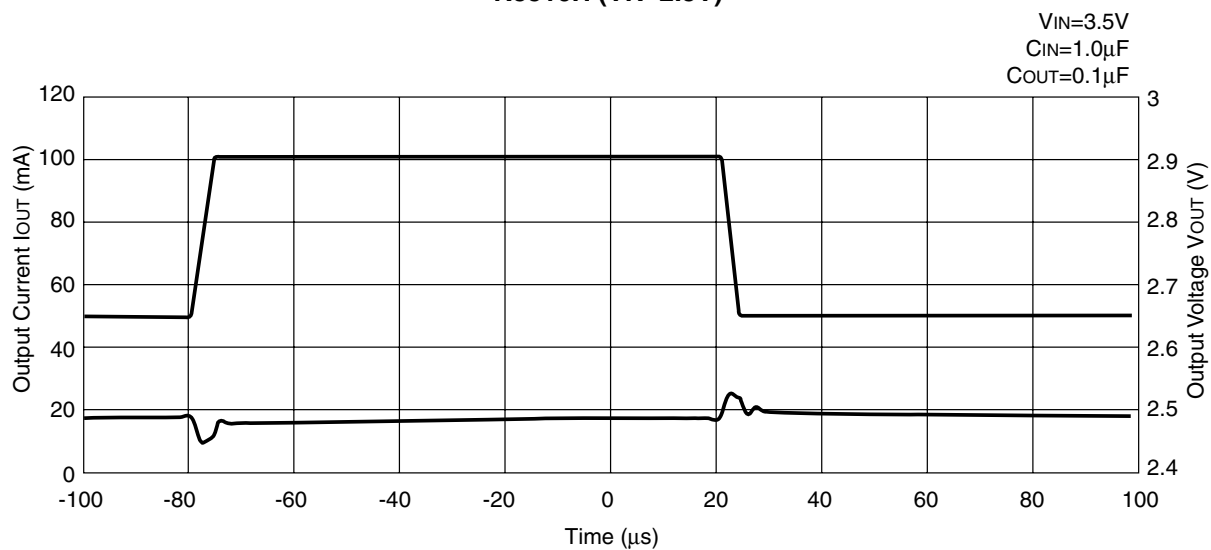

11) Detector Threshold vs. Temperature

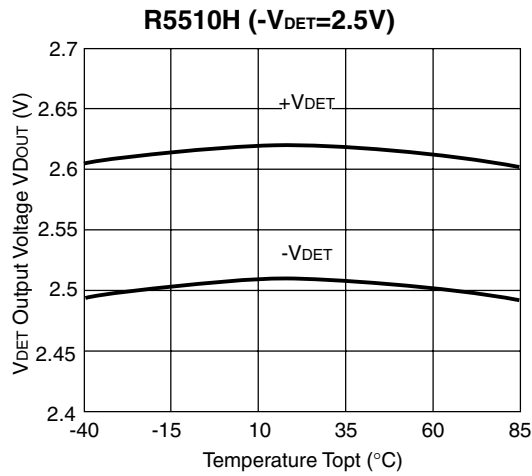
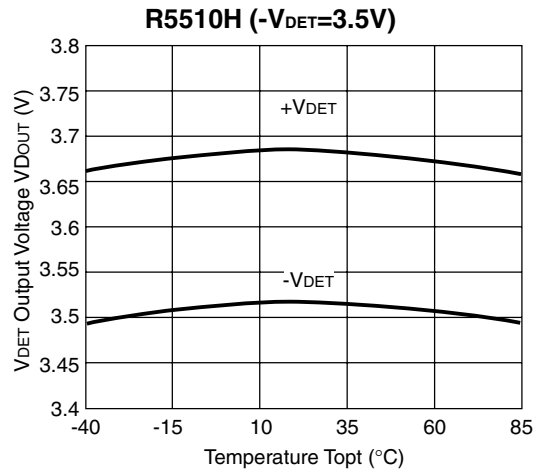
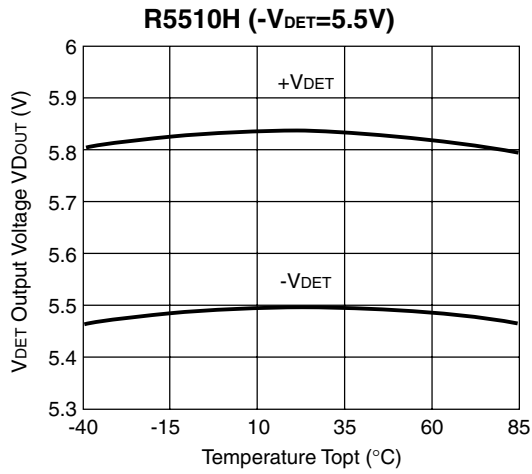

12) Detector Output Voltage vs. Input Voltage

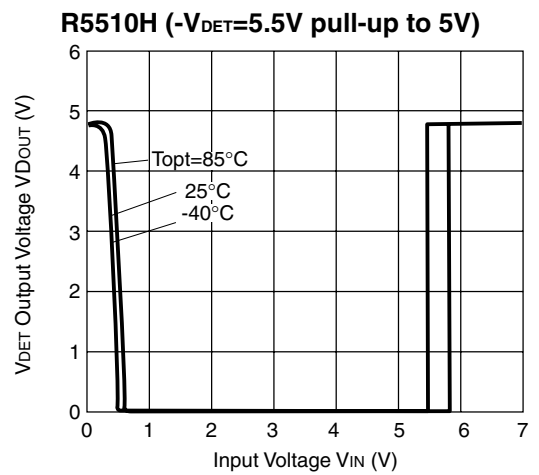
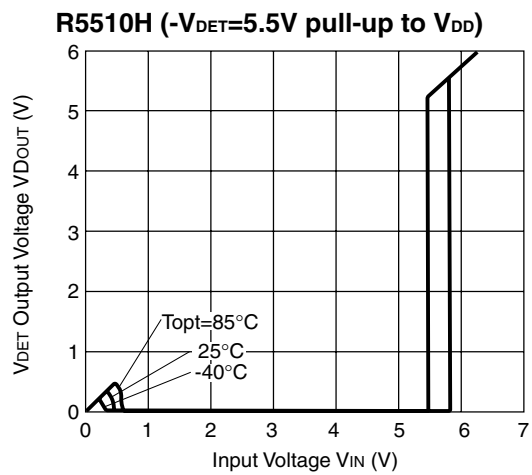

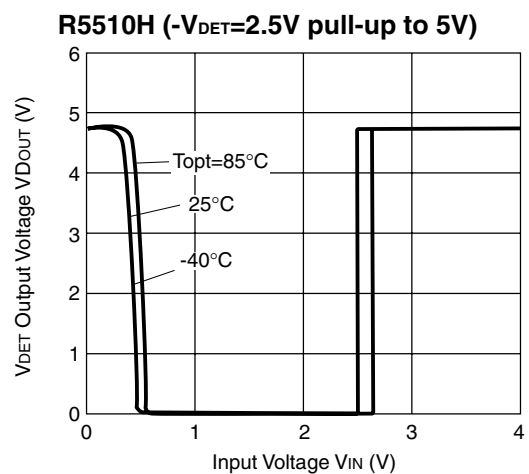
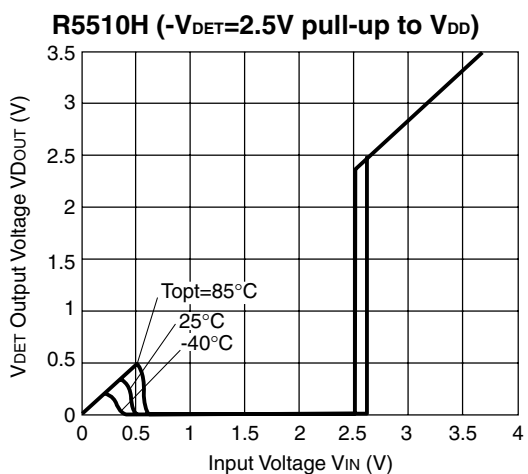
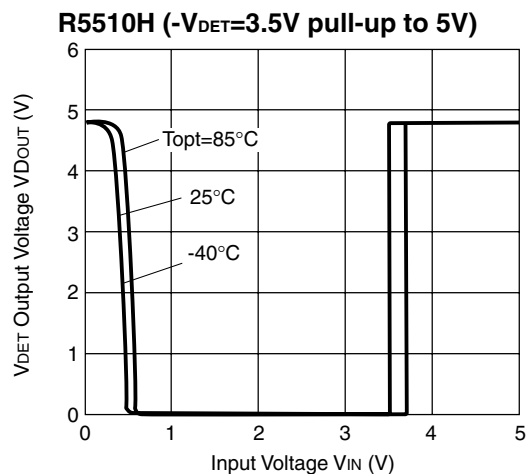
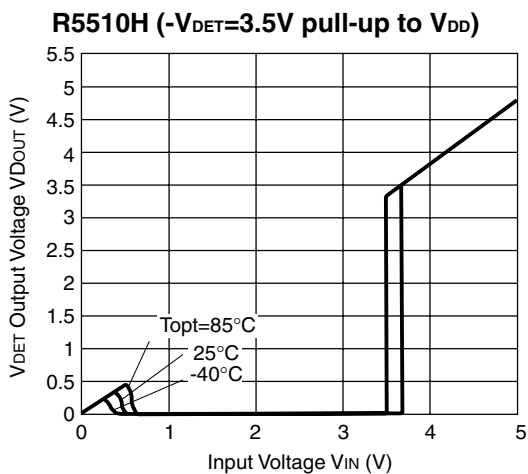

13) Nch Driver Output Current vs. V_{DS}

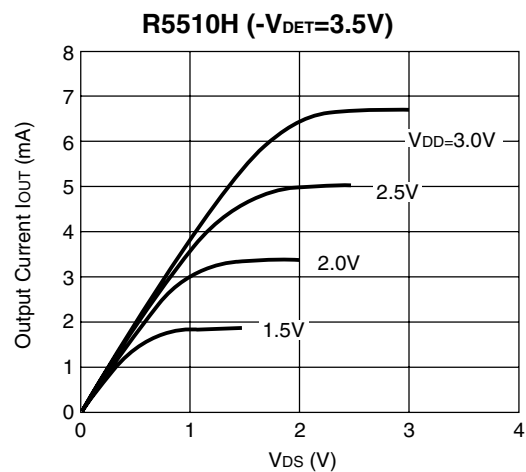
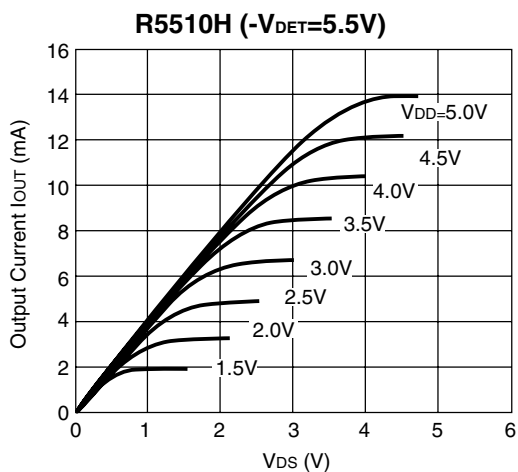

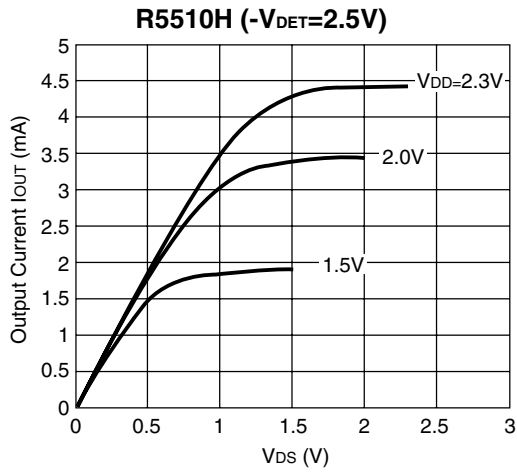

14) Nch Driver Output Current vs. Input Voltage

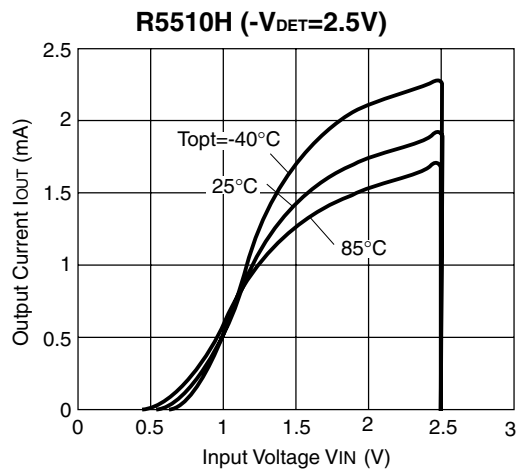
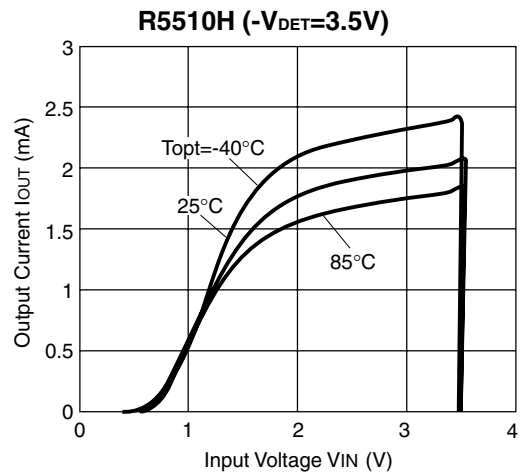
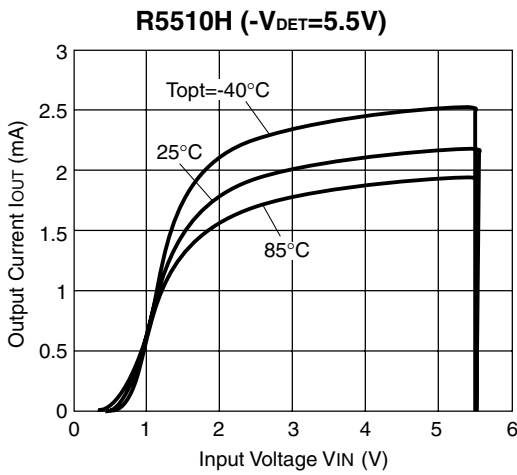

15) C_D Pin Threshold vs. Temperature

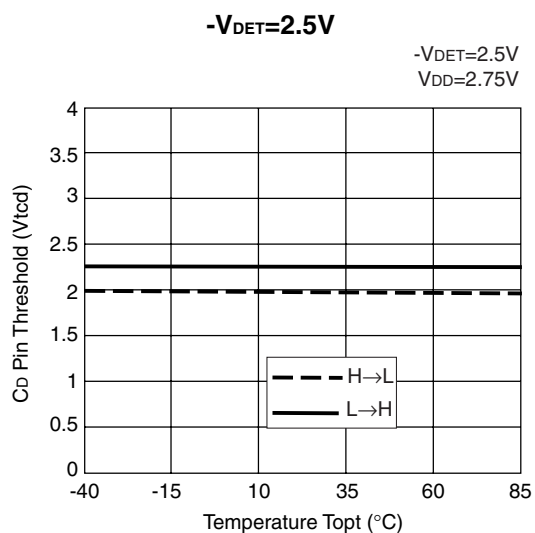
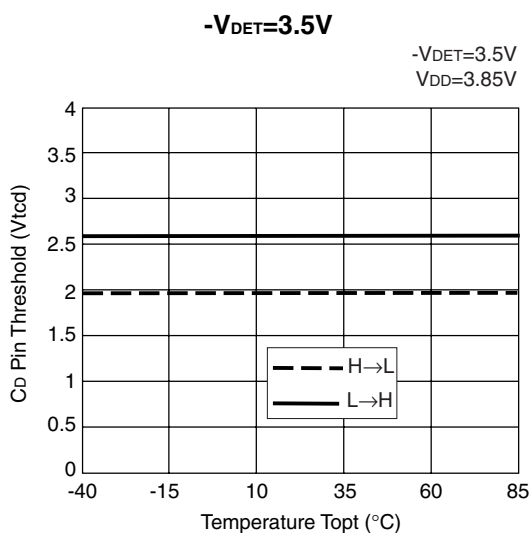
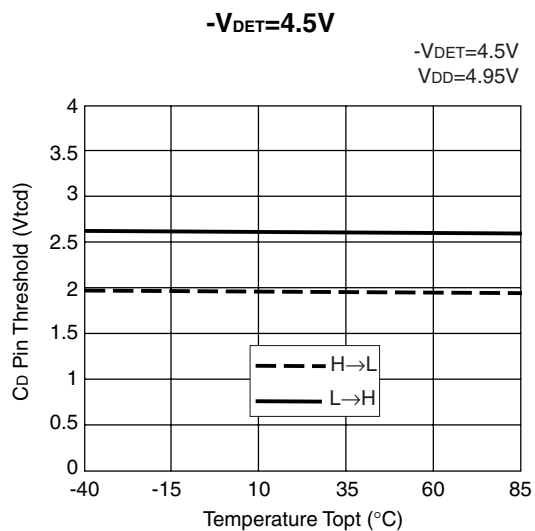
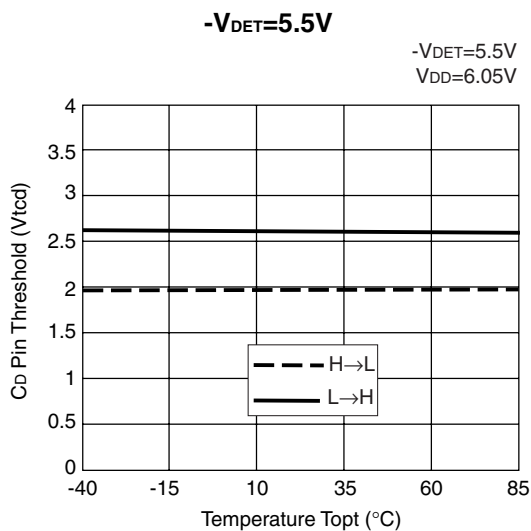

16) C_D Pin Output Current vs. Input Voltage

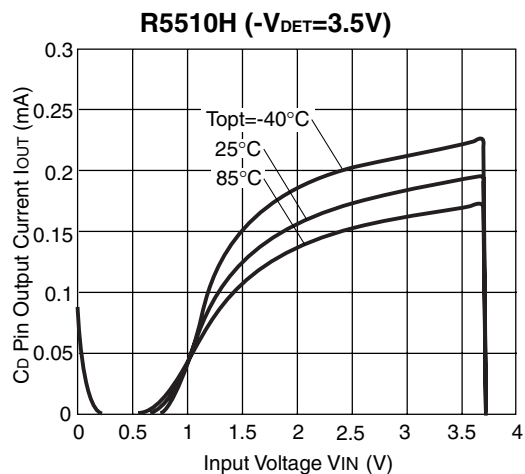
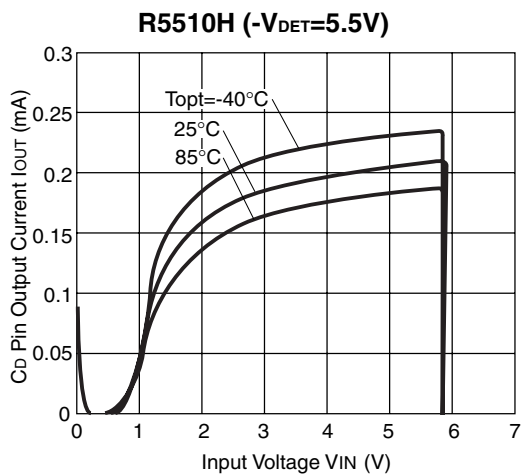

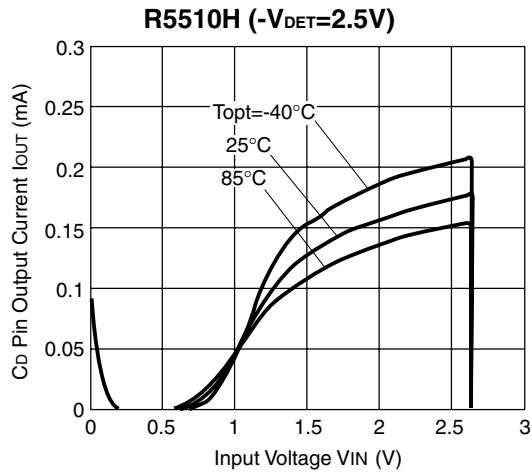

17) C_D Pin Output Current vs. V_{DS}

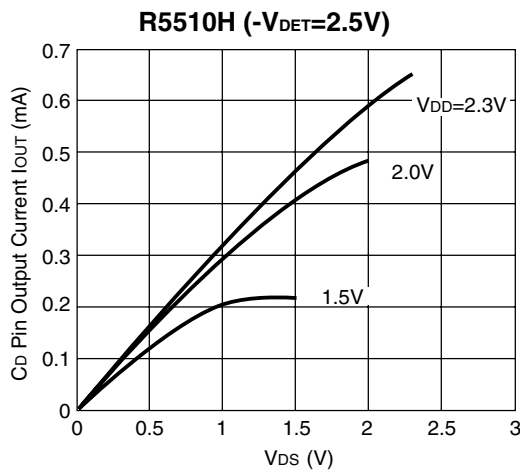
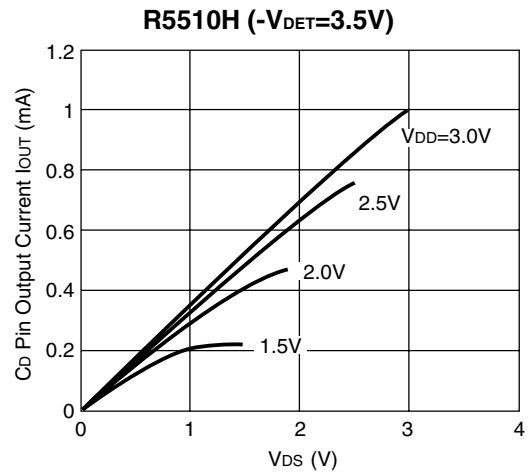
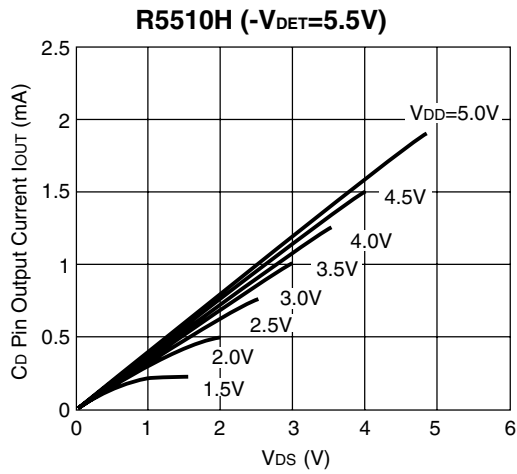

18) Output Delay Time vs. Temperature (D version)

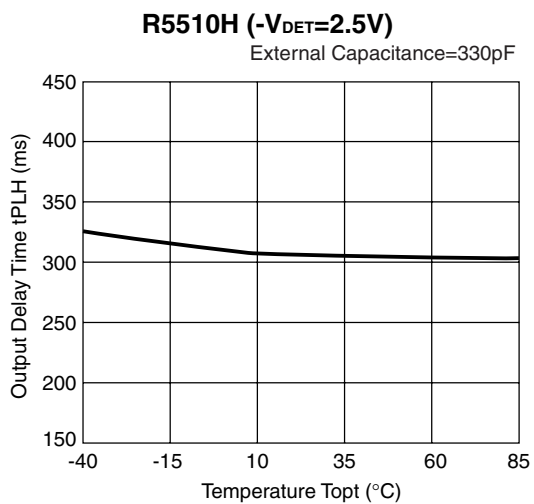
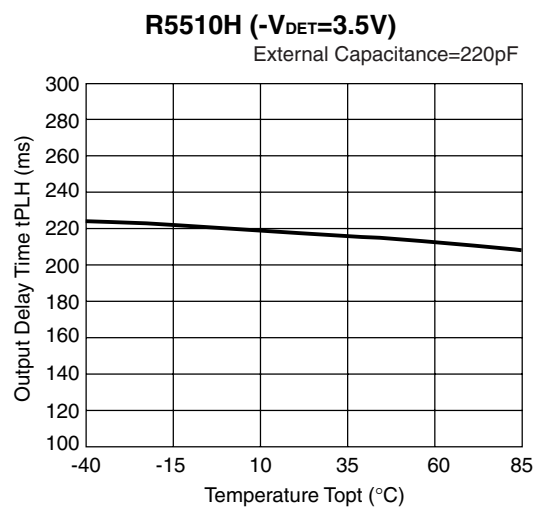
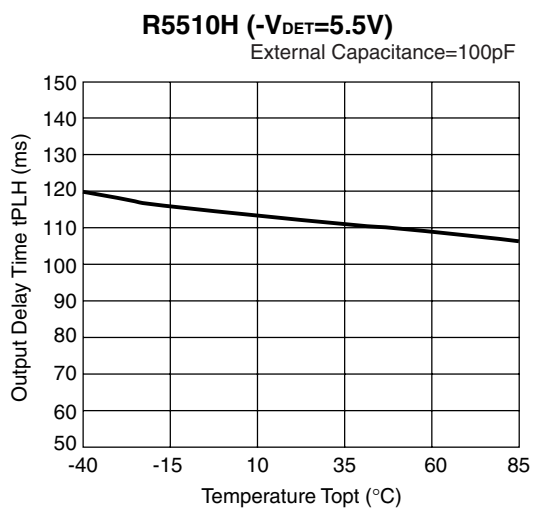

19) Output Delay Time vs. Temperature

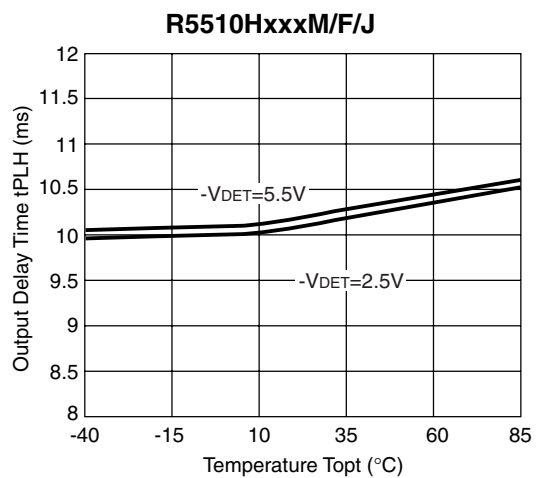
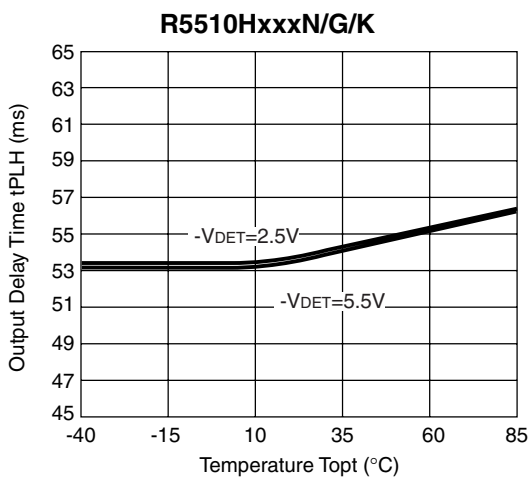

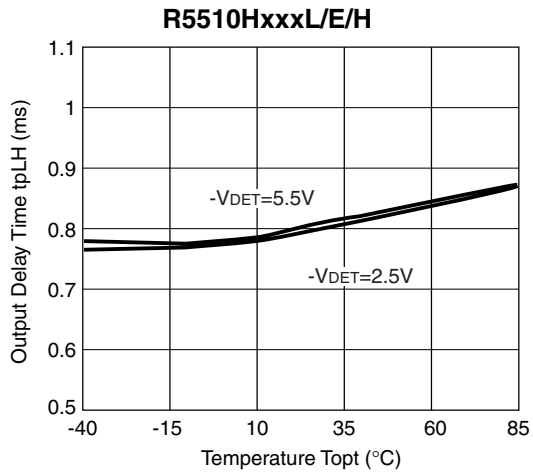

20) t_{pHL} vs. Temperature

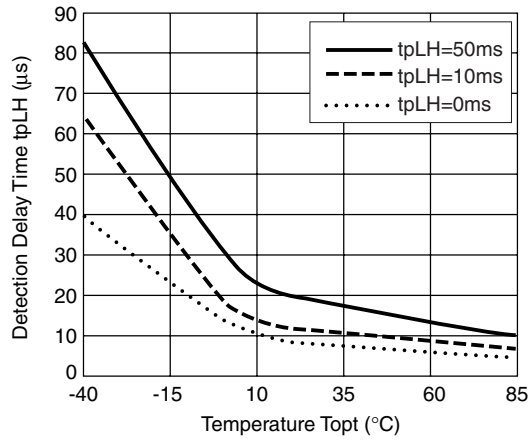

APPENDIX

(1) Reference Graph for Setting Reset Delay Time for D Type

*Reference Graph

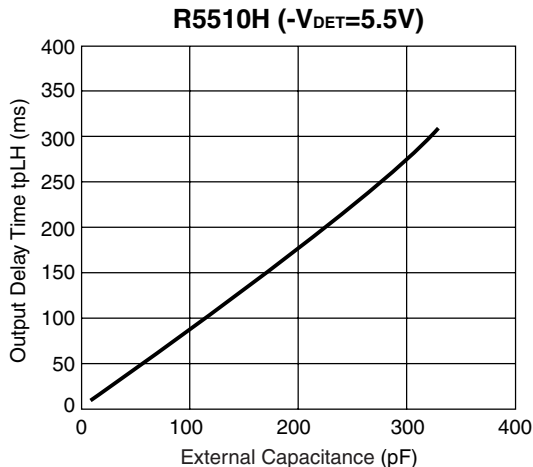

(2) Notes on Output Voltage Settings for E/F/G type

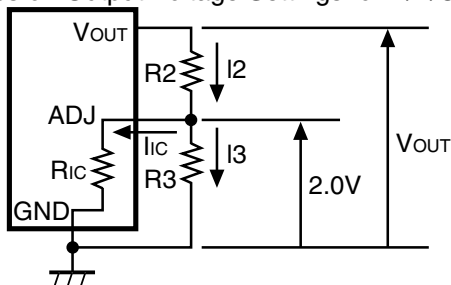

Figure 1. Adjustable Regulator(E/F/G type)

The Output Voltage of Regulator in R5510HxxxE/F/G may be adjustable for any output voltage between its 2V reference and its V_{DD} setting level. An external pair of resistors is required, as shown in Figure 1.

The complete equation for the output voltage is described step by step as follows;

$$I_2 = I_{1C} + I_3 \dots\dots\dots(1)$$

$$I_3 = 2.0/R_3 \dots\dots\dots(2)$$

thus,

$$I_2 = I_{1C} + 2.0/R_3 \dots\dots\dots(3)$$

therefore,

$$V_{OUT} = 2.0 + R_2 \times I_2 \dots\dots\dots(4)$$

then put Equation (3) into Equation (4), then

$$V_{OUT} = 2.0 + R2 \times (I_{ic} + 2.0/R3)$$

$$= 2.0 \times (1 + R2/R3) + R2 \times I_{ic} \dots\dots\dots (5)$$

where 2nd term, or $R2 \times I_{ic}$ will produce an error in V_{OUT} .

TYPICAL APPLICATION

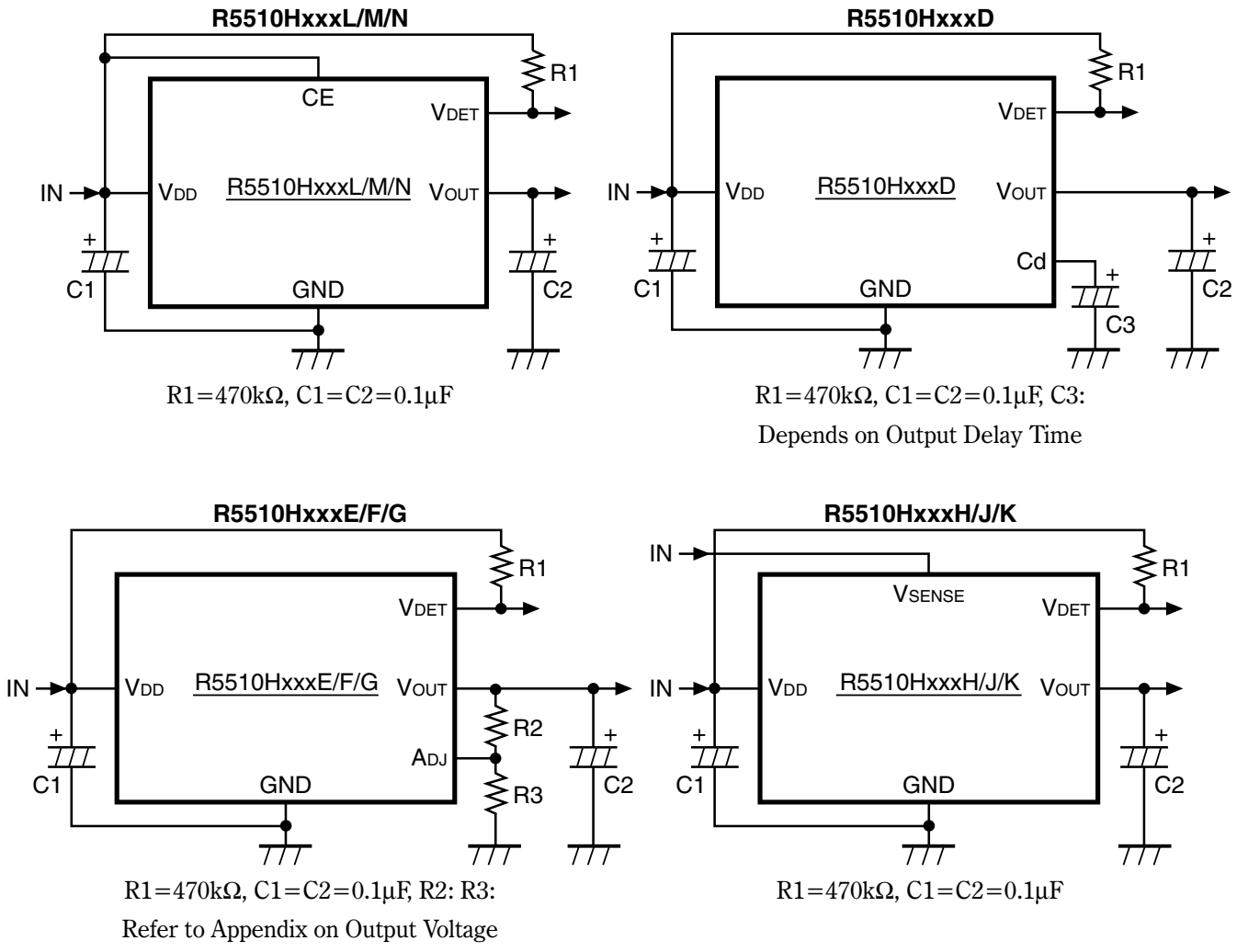

• SOT-89-5

Unit: mm

PACKAGE DIMENSIONS

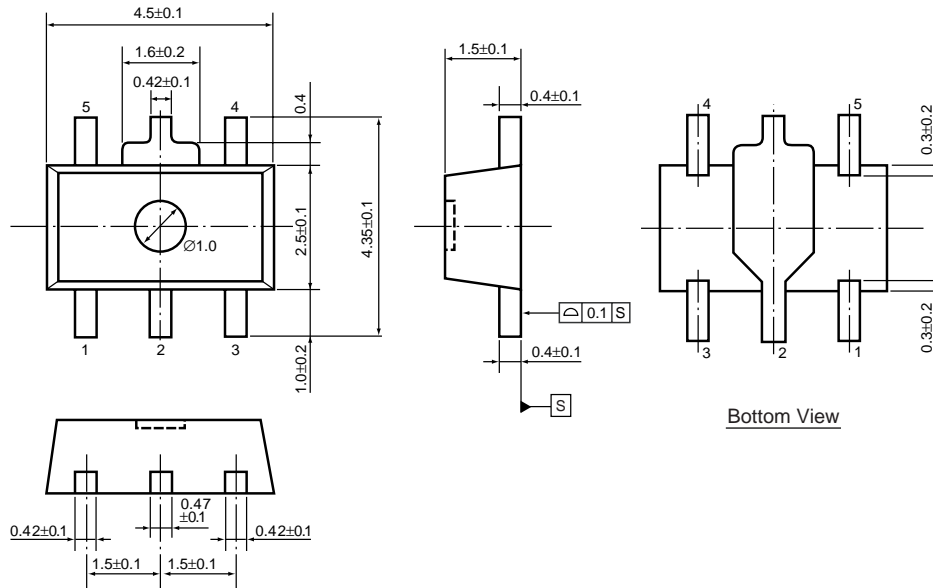

TAPING SPECIFICATION (T1: Standard Type)

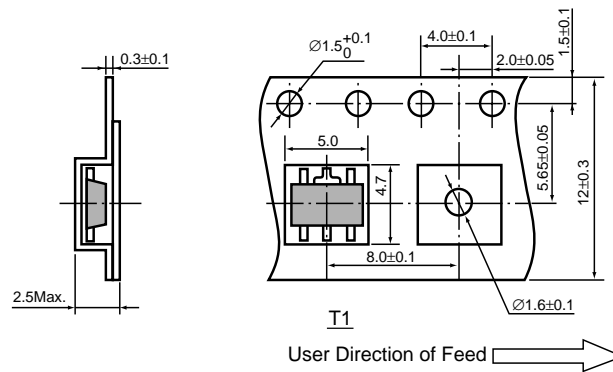

TAPING REEL DIMENSIONS REUSE REEL (EIAJ-RRM-12Bc)

(1reel=1000pcs)

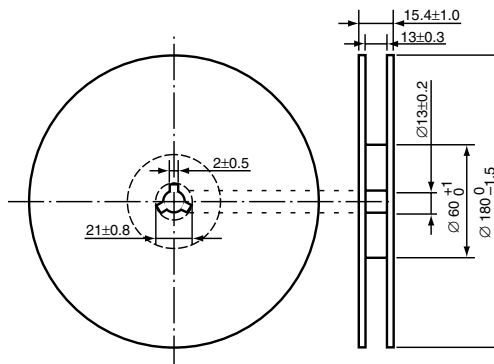

POWER DISSIPATION (SOT-89-5)

This specification is at mounted on board. Power Dissipation (P_D) depends on conditions of mounting on board. This specification is based on the measurement at the condition below:

Measurement Conditions

	High Wattage Land Pattern	Standard Land Pattern
Environment	Mounting on Board (Wind velocity=0m/s)	Mounting on Board (Wind velocity=0m/s)
Board Material	Glass cloth epoxy plastic (Double sided)	Glass cloth epoxy plastic (Double sided)
Board Dimensions	30mm × 30mm × 1.6mm	50mm × 50mm × 1.6mm
Copper Ratio	Top side : Approx. 20% , Back side : Approx. 100%	Top side : Approx. 10% , Back side : Approx. 100%
Through-hole	φ0.85mm × 10pcs	-

Measurement Result

($T_{opt}=25^{\circ}C, T_{jmax}=125^{\circ}C$)

	High Wattage Land Pattern	Standard Land Pattern	Free Air
Power Dissipation	1300mW	900mW	500mW
Thermal Resistance	77°C/W	111°C/W	200°C/W

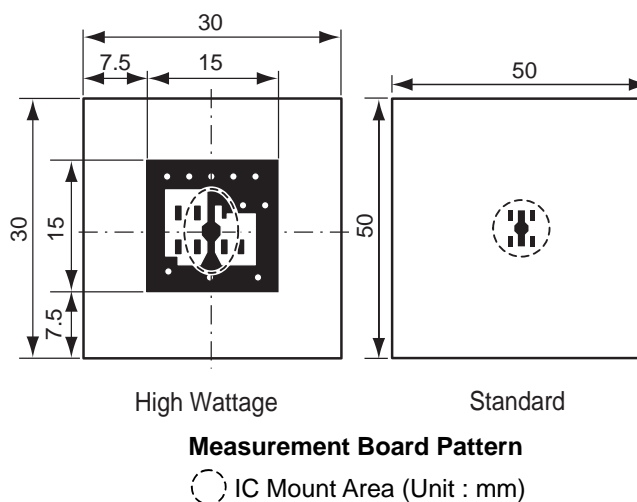
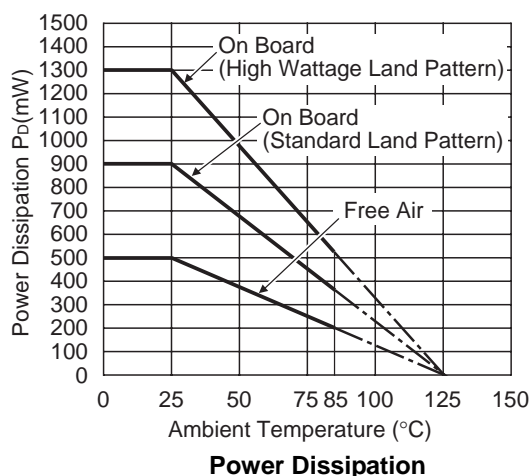

RECOMMENDED LAND PATTERN (SOT-89-5)

